

Pressure Balance Shower Faucet Installation Manual

W-308(ES)

Warranty Duration

All components of this faucet system are covered under a lifetime limited warranty, ensuring they are free from defects in material and workmanship for the original purchaser.

Repair and Replacement

If the product shows defects in material or workmanship under normal use and within the warranty period, we will, at our discretion, either repair the product or provide a replacement at no cost to the original purchaser. Please note that proof of purchase (e.g., an invoice) is required when requesting service. The warranty does not cover damages caused by improper installation, misuse, or modifications.

Exclusions

We shall not be responsible for the following cases:

- Damage to the product caused by improper installation, misuse, unauthorized repair or replacement, or abuse (including damage during shipment).
- Damage to the product caused by improper dismantling after installation.
- Damage resulting from abnormal water pressure or impurities in water pipes, which is not covered under this warranty.
- Rust on the product due to insufficient care and maintenance, which is not covered under this warranty.
- Damage caused by natural disasters such as fire, flood, earthquake, lightning storms, etc., which is not covered under this warranty.

I hope this helps! If you have any further questions or concerns, please let me know.

Having Trouble? Contact us.

✉ Email: info@faucetsupport.com

☎ Toll Free: 1-888-969-6880





M6989-6
SFS-1186

CONTENT

Pressure Balance Shower Faucet Installation Manual -----(1-5)

CONTENIDO

Manual de Instalación del Grifo de Ducha con Equilibrio de Presión -----(6-10)

◆ Installation and Maintenance Instructions

1. Check the accessories list to verify that all parts are complete in this package.
2. Do not disassemble the main body by yourself.
3. Connect inlet pipes to supply valves.
4. Make sure inlet pipes and supply valves have no impurities and are cleaned, with no impurities in the pipeline.
5. After installation, check all joints for leakages.
6. Do not leave the rain shower system exposed to a severely corrosive environment.

Do's

1. In order to keep the mixer surface bright, please clean the mixer regularly.
2. Rinse the faucet with clean water and wipe it with a soft cotton cloth.
3. Use one of the following cleaners to remove dirt from the surface:
 - a. Mild liquid cleaner.
 - b. Colorless glass cleaner and powder cleaner that do not cause abrasion and can be dissolved completely.
 - c. Polish liquid that does not cause abrasion.

Don'ts

1. Avoid using cleaning powder, harsh cleaning chemicals, brushes and coarse cloth to prevent scratching and friction.
2. Do not use acid cleaners to clean the faucet as they may cause surface corrosion of the faucet. If the faucet is exposed to harmful acid substances, please rinse it immediately with water.

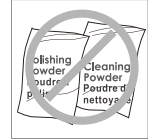
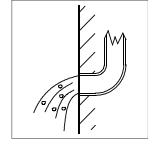
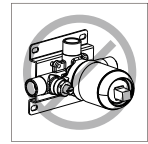

Tools Needed:

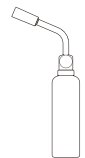
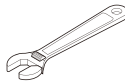
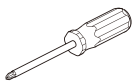

◆ Single-Function Rain Shower System Accessories List

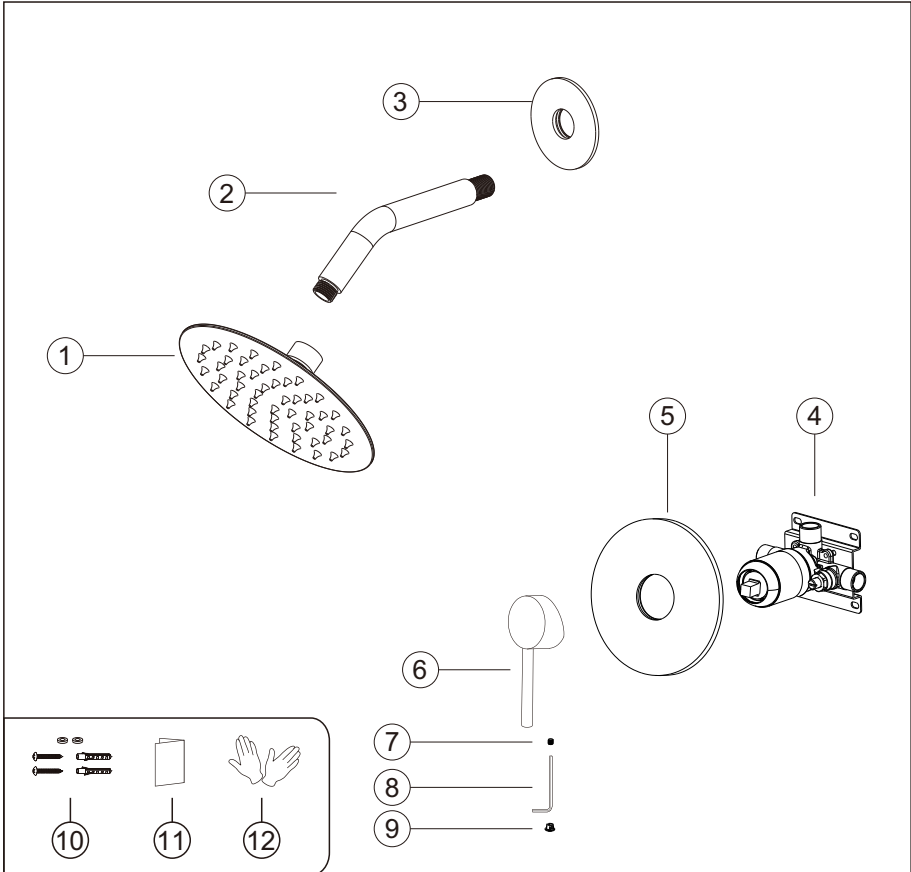

No.	Part name	Qty	No.	Part name	Qty
1	Shower head	1	7	Handle screw	1
2	Shower arm	1	8	Handle wrench	1
3	Shower arm flange	1	9	Handle cap	1
4	Main body	1	10	Main body spare parts	1 set
5	Deck plate	1	11	Instruction manual	1
6	Handle	1	12	Gloves	1 pair

◆ Essential Dimensions & Water Pipe Lines

Unit: mm/inch

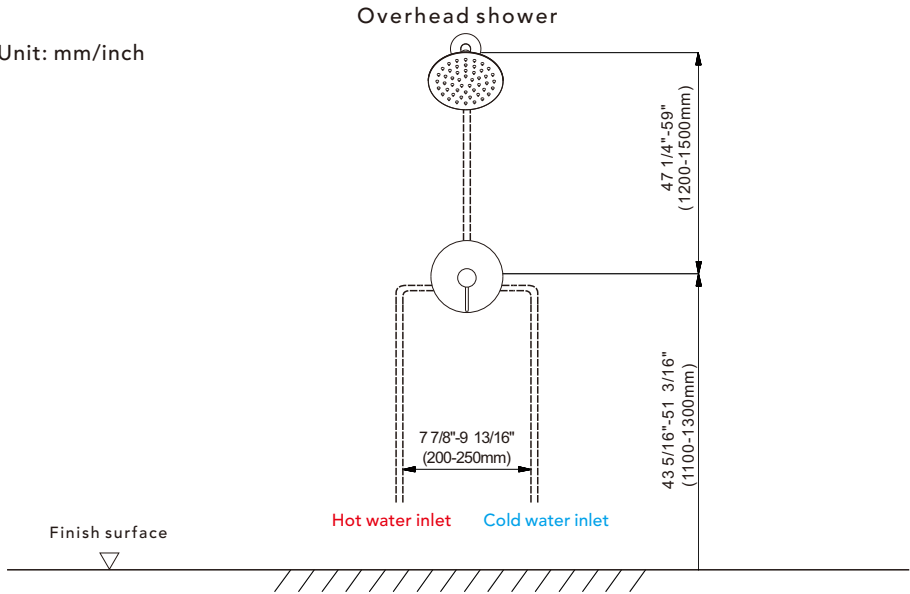

◆ Installation Depth of the Shower Arm

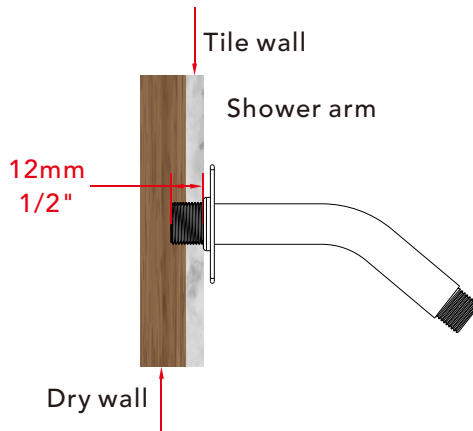

The thickness of the tile must be calculated for installation.

Connector size of male thread: USA: 1/2"-14NPT, Canada: 1/2"-14NPT, Europe: G1/2".

◆ Installation Depth of the Main Body

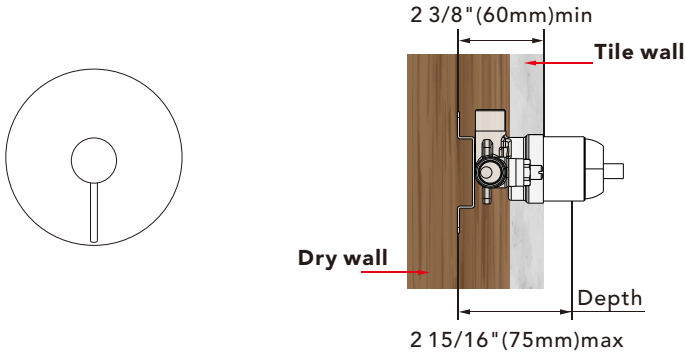

- Notice:** 1. The installation depth of the main body should be no less than 2 3/8" (60mm) and no more than 2 15/16" (75mm), including the thickness of the tile. Otherwise, the deck plate cannot be installed.
2. The opening size of ceramic tile shall be smaller than the deck plate size.

◆ Piping Instructions before Tiling

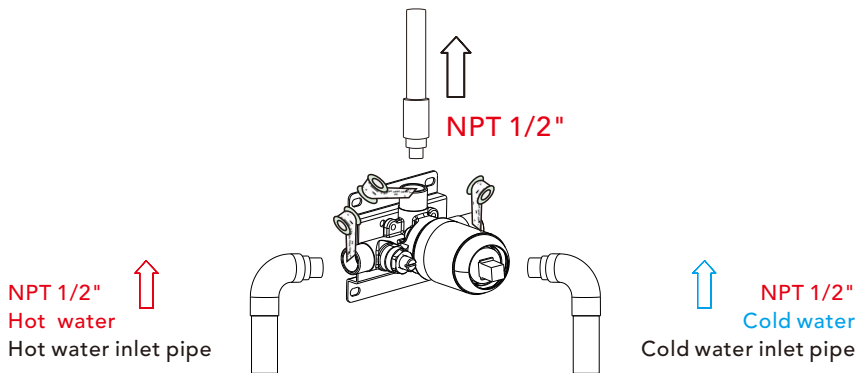

1. As shown in the figure, the inlet and outlet pipes are pre-buried. Please pay attention to the correct direction when installing the pre-buried main body.
 2. Before tiling, turn on the water to test whether the left and right inlet pipes are tightly connected without leakage.
- Then, adjust the flow switch to the "on" position to check for leaks in the mixed outlet pipes.

◆ Main Body Valve Installation

Step1

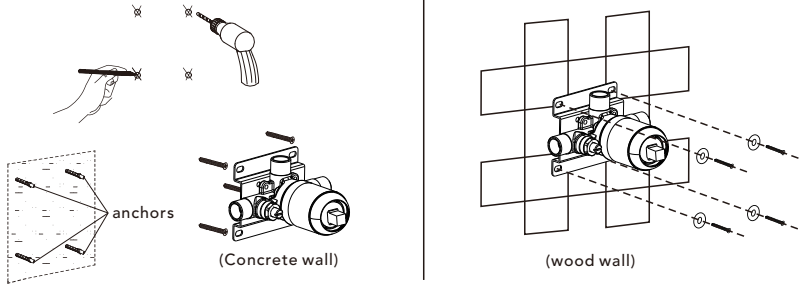

1. Make marks according to the size of the main body valve, and then drill anchors into the wall (concrete wall).
 2. Lock the main body to wood directly with screws (wood wall).
 3. When installing the main body, please mark the UP side up and do not install it upside down.
- ▲ Please note that the level meter should be parallel to the wall; otherwise, the deck plate cannot be installed.

◆ Shower Head Installation

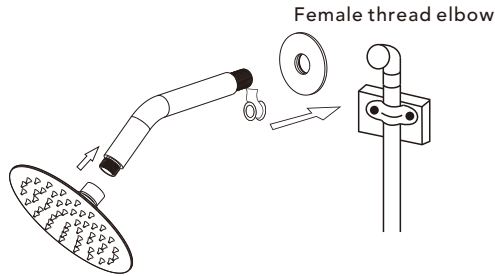

1. Connect shower arm with the cover before screwing arm into riser connection to prevent damage.
2. As shown in the diagram, wrap waterproof tape around the other end and screw it into the water pipe; then connect the shower head to one end of the shower arm.
3. Do not over tighten shower head. It is 360° swivel connection.

◆ Instalación y Cuestiones de Mantenimiento

1. Compruebe la lista de accesorios para verificar que todas las piezas están completas en este paquete.
2. No desmonte el cuerpo principal por su cuenta.
3. Conecte las tuberías de entrada a las válvulas de suministro.
4. Asegúrese de que las tuberías de entrada y las válvulas de suministro no tengan impurezas y estén limpias, y de que no haya impurezas en la tubería.
5. Después de la instalación, compruebe que todas las uniones no presenten fugas.
6. No deje el sistema de ducha tipo lluvia expuesto a un entorno altamente corrosivo.

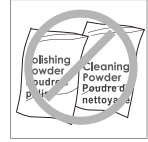
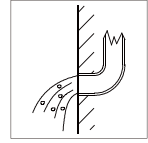
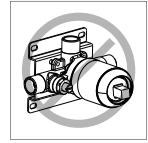

Qué Sí Hacer

1. Para mantener brillante la superficie del grifo, límpielo regularmente.
2. Enjuague el grifo con agua limpia y séquelo con un paño de algodón suave.
3. Utilice uno de los siguientes limpiadores para eliminar la suciedad de la superficie:
 - a. Limpiador líquido suave.
 - b. Limpiador de vidrio incoloro y limpiador en polvo que no causen abrasión y se disuelvan completamente.
 - c. Líquido de pulido que no cause abrasión.

Qué No Hacer

1. Evite el uso de polvos de limpieza, productos químicos de limpieza agresivos, cepillos y trapos ásperos para evitar arañazos y rozaduras.
2. No utilice limpiadores ácidos para limpiar el grifo, ya que pueden causar corrosión en la superficie. Si el grifo entra en contacto con sustancias ácidas dañinas, enjuáguelo inmediatamente con agua.

Herramientas Necesarias:

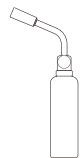
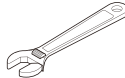
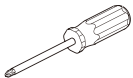

◆ Sistema de Ducha de Lluvia Monofunción

Lista de Accesorios

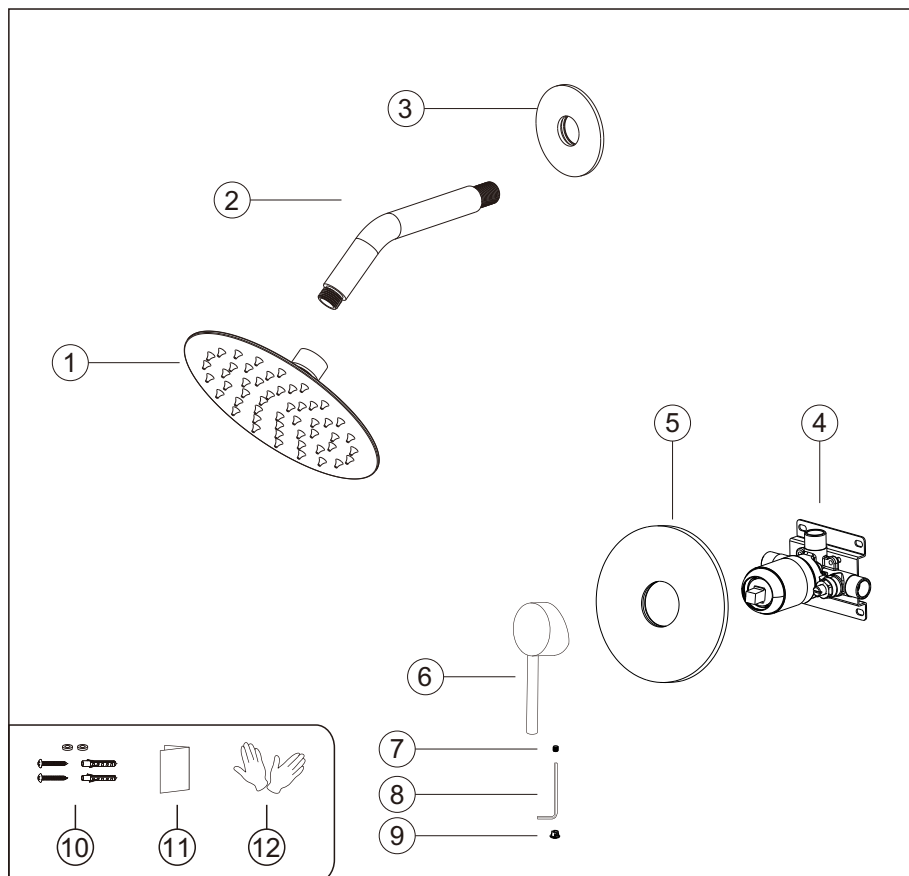

N.º	Nombre de la pieza	Cantidad	N.º	Nombre de la pieza	Cantidad
1	Alcachofa de la ducha	1	7	Tornillo de la manija	1
2	Brazo de ducha	1	8	Llave de la manija	1
3	Brida del brazo de ducha	1	9	Tapa de la manija	1
4	Cuerpo principal	1	10	Repuestos del cuerpo principal	1 juego
5	Placa de cubierta	1	11	Manual de instrucciones	1
6	Manija	1	12	Guantes	1 par

◆ Dimensiones Esenciales y Líneas de Tubería de Agua

Unidad: mm/pulgada

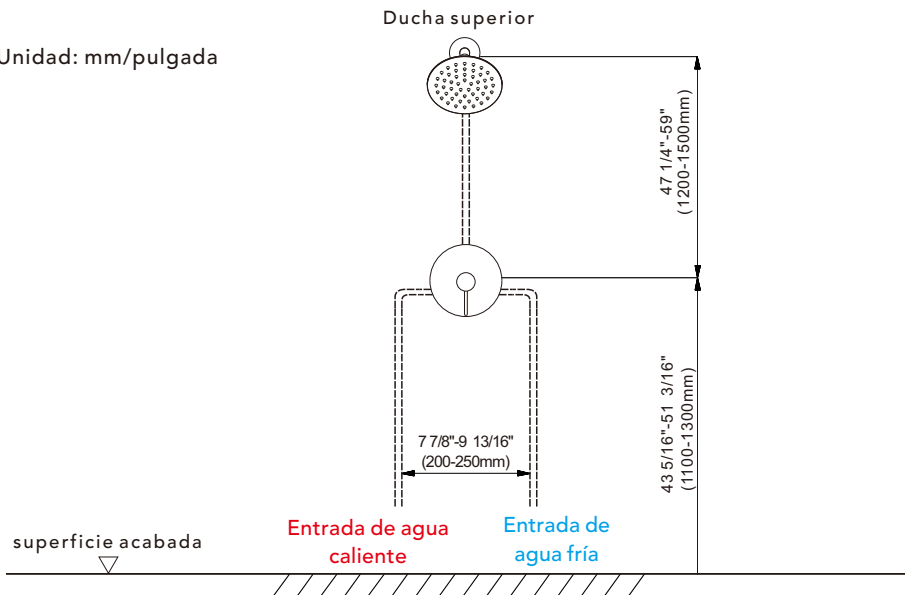

◆ Profundidad de Instalación del Brazo de Ducha

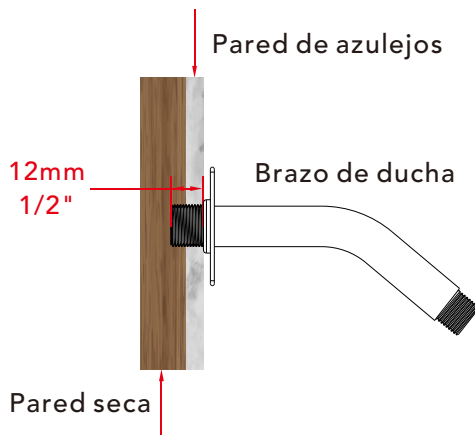

El grosor del azulejo debe ser calculado para la instalación.

Tamaño del conector de rosca macho: EE. UU.: $1/2'' - 14\text{NPT}$, Canadá: $1/2'' - 14\text{NPT}$, Europa: $G1/2''$.

◆ Profundidad de Instalación del Cuerpo Principal

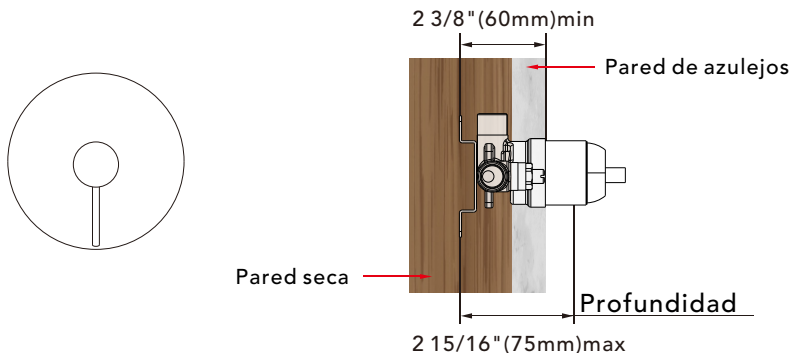

Aviso: 1. La profundidad de instalación del cuerpo principal no debe ser inferior a 2 3/8" (60 mm) y no más de 2 15/16" (75mm), incluyendo el grosor del azulejo. De lo contrario, la placa de cubierta no podrá ser instalada.

2. El tamaño de apertura del azulejo cerámico debe ser menor que el tamaño de la placa de cubierta.

◆ Instrucciones de Tuberías antes del Alicatado

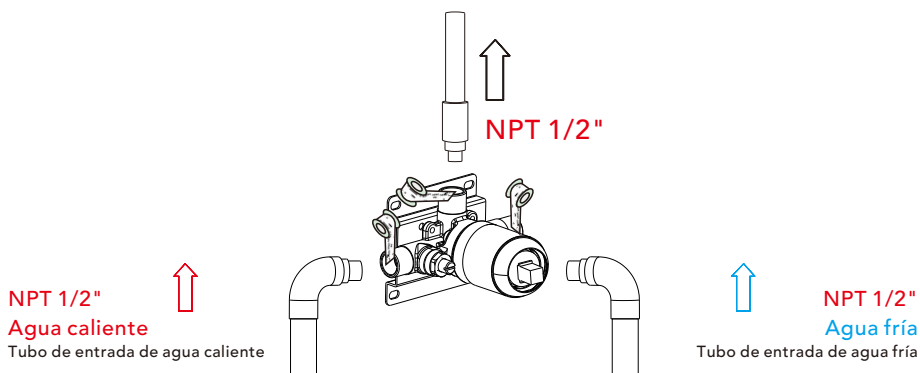

1. Como se muestra en la figura, las tuberías de entrada y salida están pre-enterradas. Por favor, preste atención a la dirección correcta al instalar el cuerpo principal pre-enterrado.

2. Antes de colocar los azulejos, abra el agua para probar si las tuberías de entrada izquierda y derecha están conectadas herméticamente sin fugas. Luego, ajuste el interruptor de flujo a la posición "on" para comprobar si hay fugas en las tuberías de salida mezcladas.

◆ Instalación de la Válvula del Cuerpo Principal

Paso 1

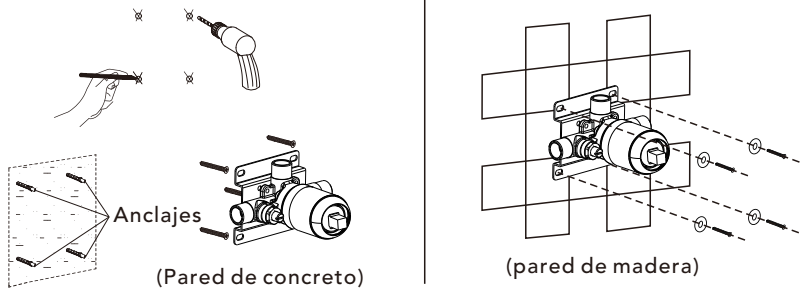

1. Marque según el tamaño de la válvula del cuerpo principal y luego perforo para colocar los anclajes en la pared (pared de concreto).
 2. Fije directamente el cuerpo principal a la madera con tornillos (pared de madera).
 3. Al instalar el cuerpo principal, por favor marque el lado UP hacia arriba y no lo instale al revés.
- ▲ Tenga en cuenta que el nivel debe estar paralelo a la pared; de lo contrario, la placa de cubierta no podrá ser instalada.

◆ Instalación del Cabezal de Ducha

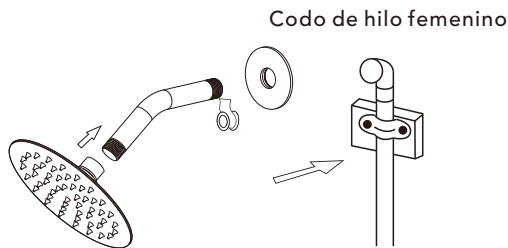

1. Conecte el brazo de la ducha con la cubierta antes de enroscar el brazo en la conexión del tubo ascendente para evitar daños.
2. Como se muestra en el diagrama, envuelva cinta impermeable alrededor del otro extremo y enrósquelo en la tubería de agua; luego conecte la alcachofa de la ducha a un extremo del brazo de la ducha.
3. No apriete demasiado la alcachofa de la ducha. Es una conexión giratoria de 360°.