

# ASSEMBLY INSTRUCTION

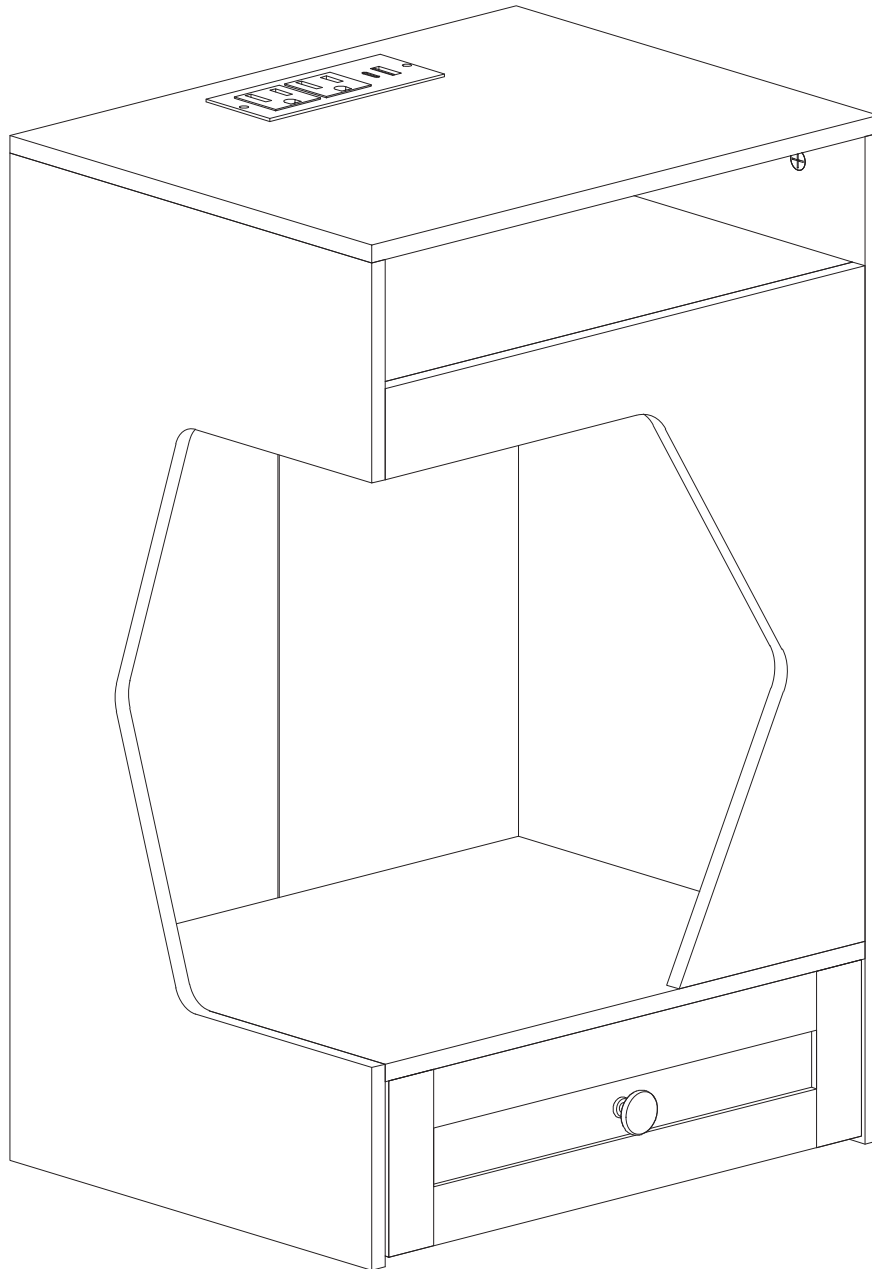

1 PER.

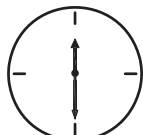

30 MIN

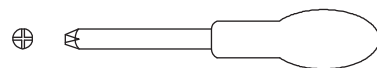

Pozi Screwdriver(NotProvided)

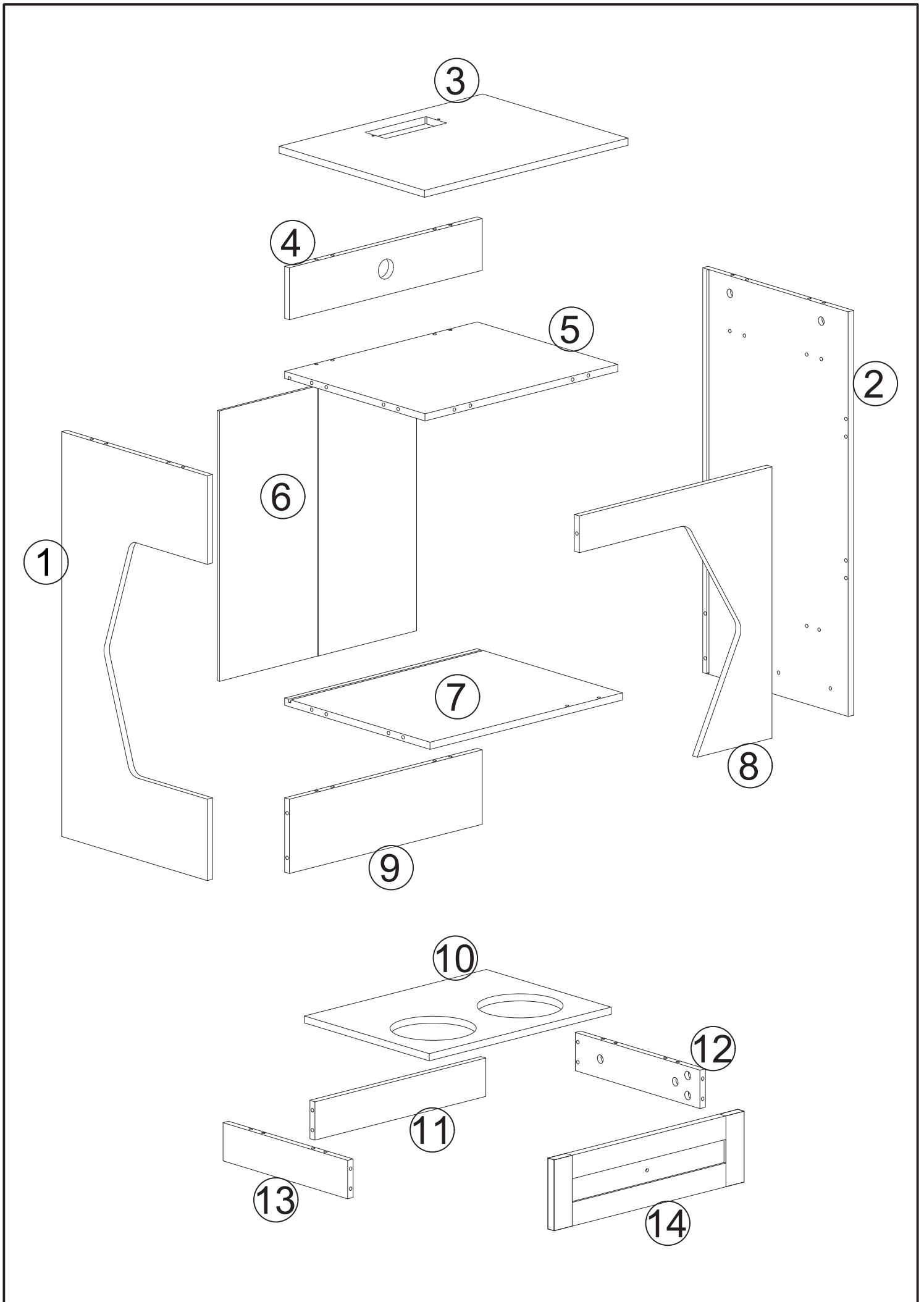

# Hardware

A	x37	B	x30	C	x37	D	x12	E	x1
		6x30mm		15x12mm		3x10mm		4x8mm	
F	x1	G	x2	H	x2	I	x1	J	x2
				3x12mm					
DR	x1	DL	x1	CL	x1	CR	x1		

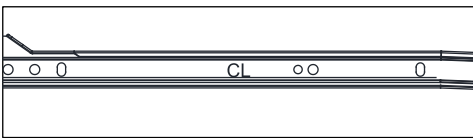

**!** you will find "CL/CR/DL/DR" steel remark on the drawer slider.

## General instructions to assemble connecting pieces

Gently screw cam bolt into the threaded anchor.	Insert the wood dowel halfway into hole.		Screw the camlock firmly into locked position.

**Important:** Please split the slider into 2 parts by pressing down on the tab shown with the arrow below

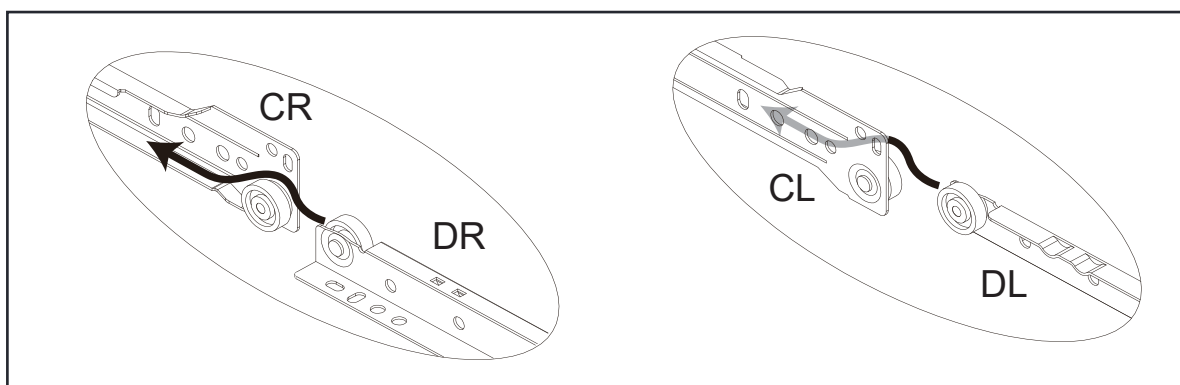

1

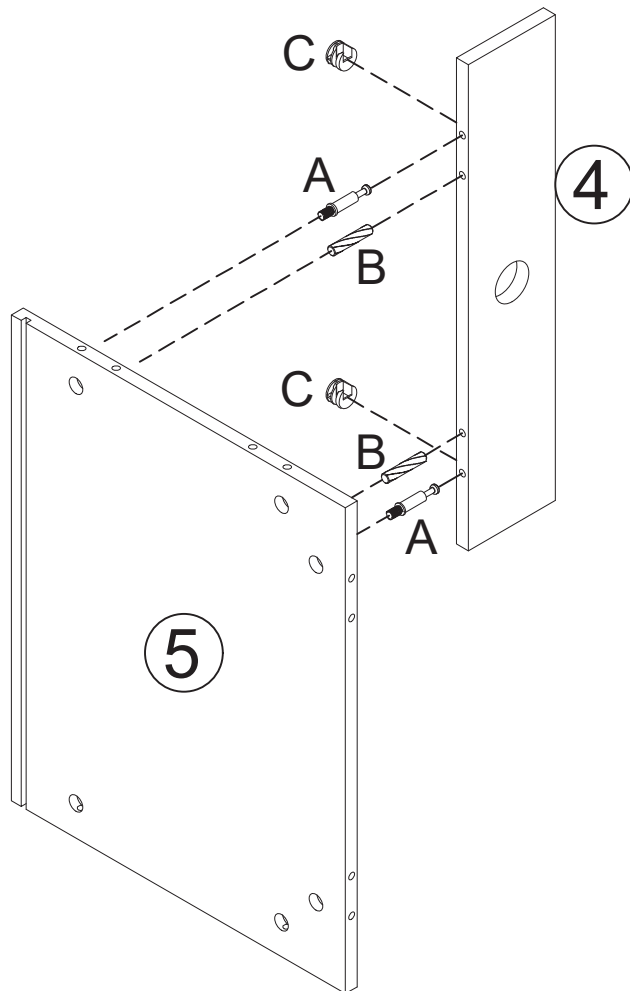

A	x2
B	x2
6x30mm	
C	x2
15x12mm	

2

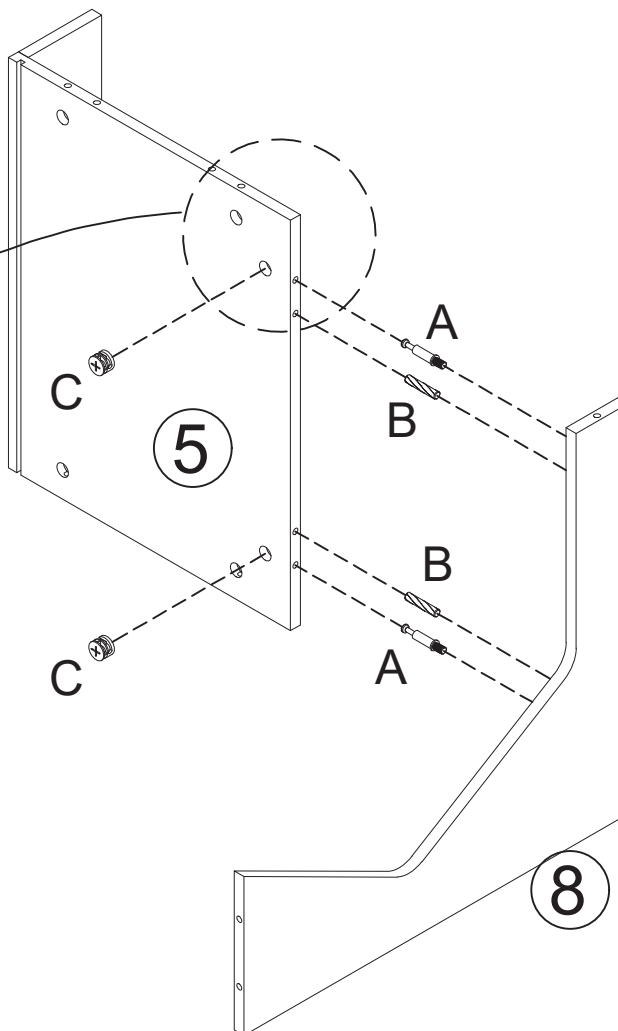
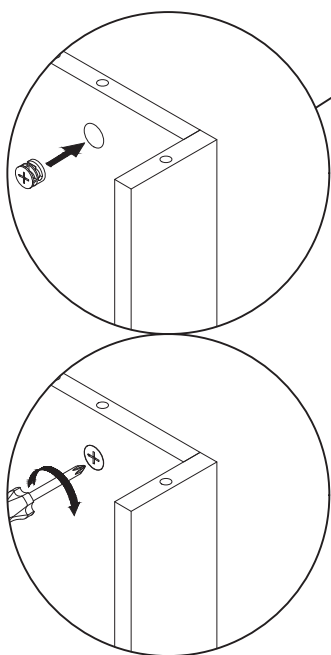

Direction of attention

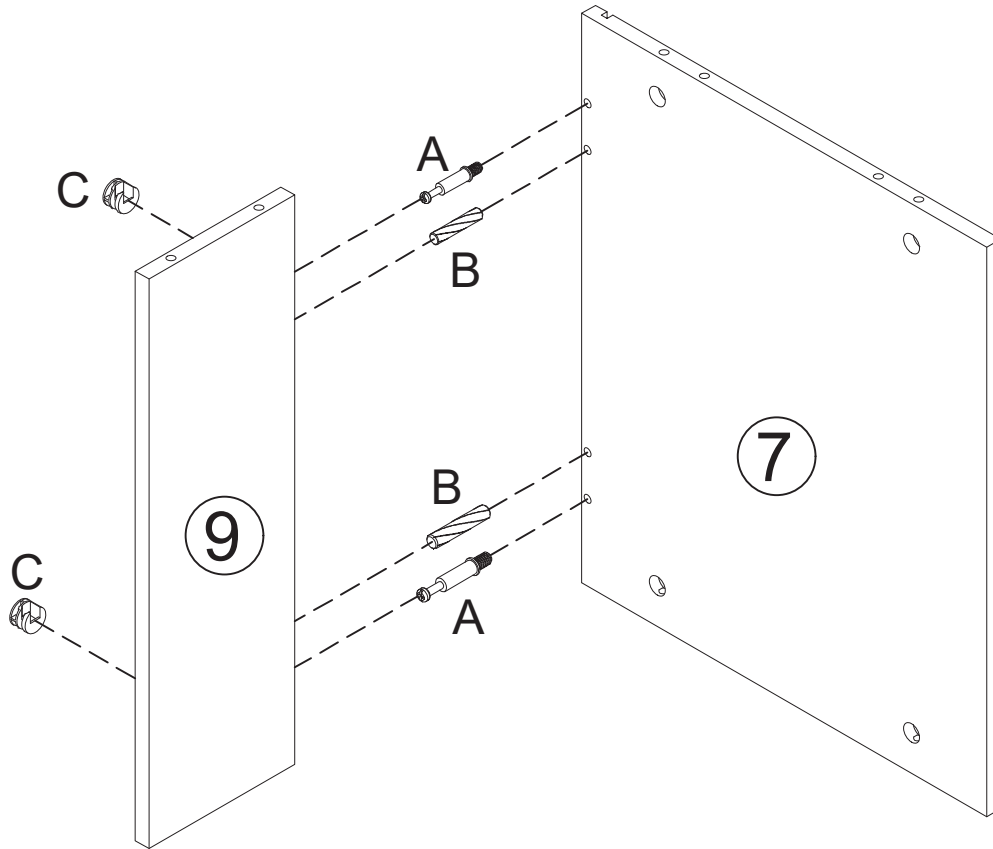

A	x2
B	x2
6x30mm	
C	x2
15x12mm	

3



A	x2
	
B	x2
	
6x30mm	
C	x2
	
15x12mm	



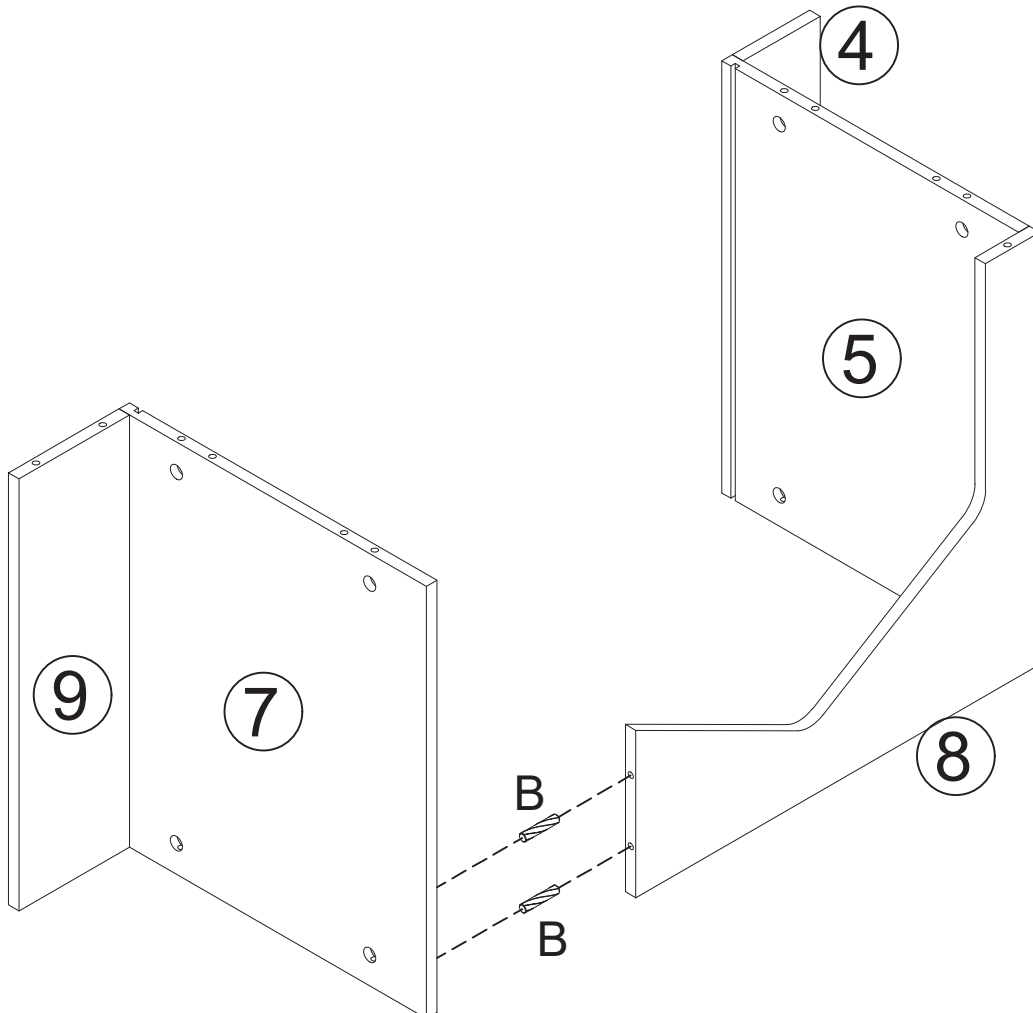

4

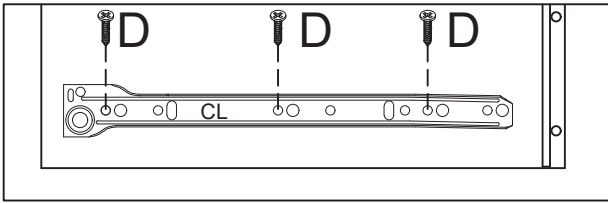
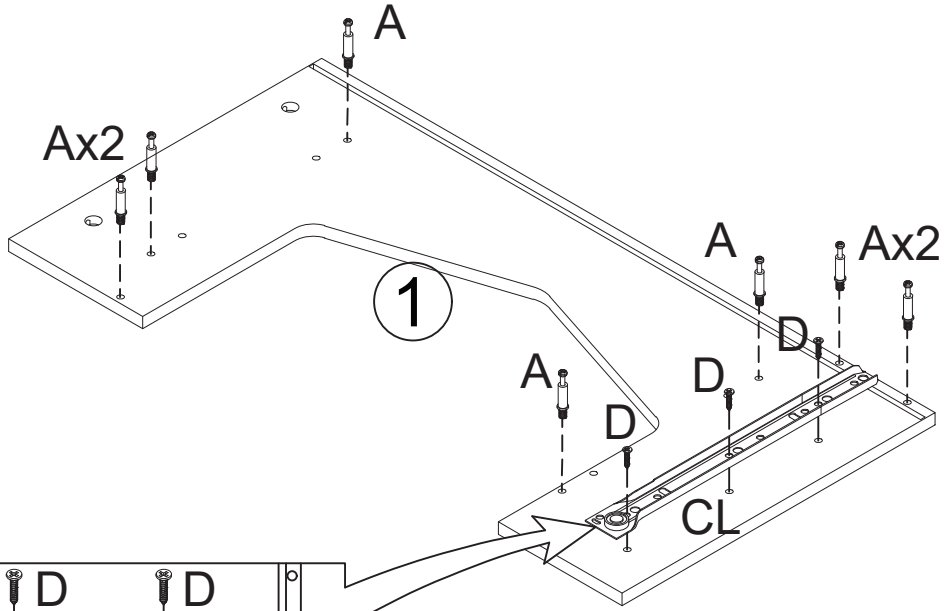

B	x2
	
6x30mm	

5

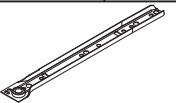

A	x7
	
B	x4
	
6x30mm	
C	x7
	
15x12mm	
D	x3
	
3x10mm	
CL	x1
	

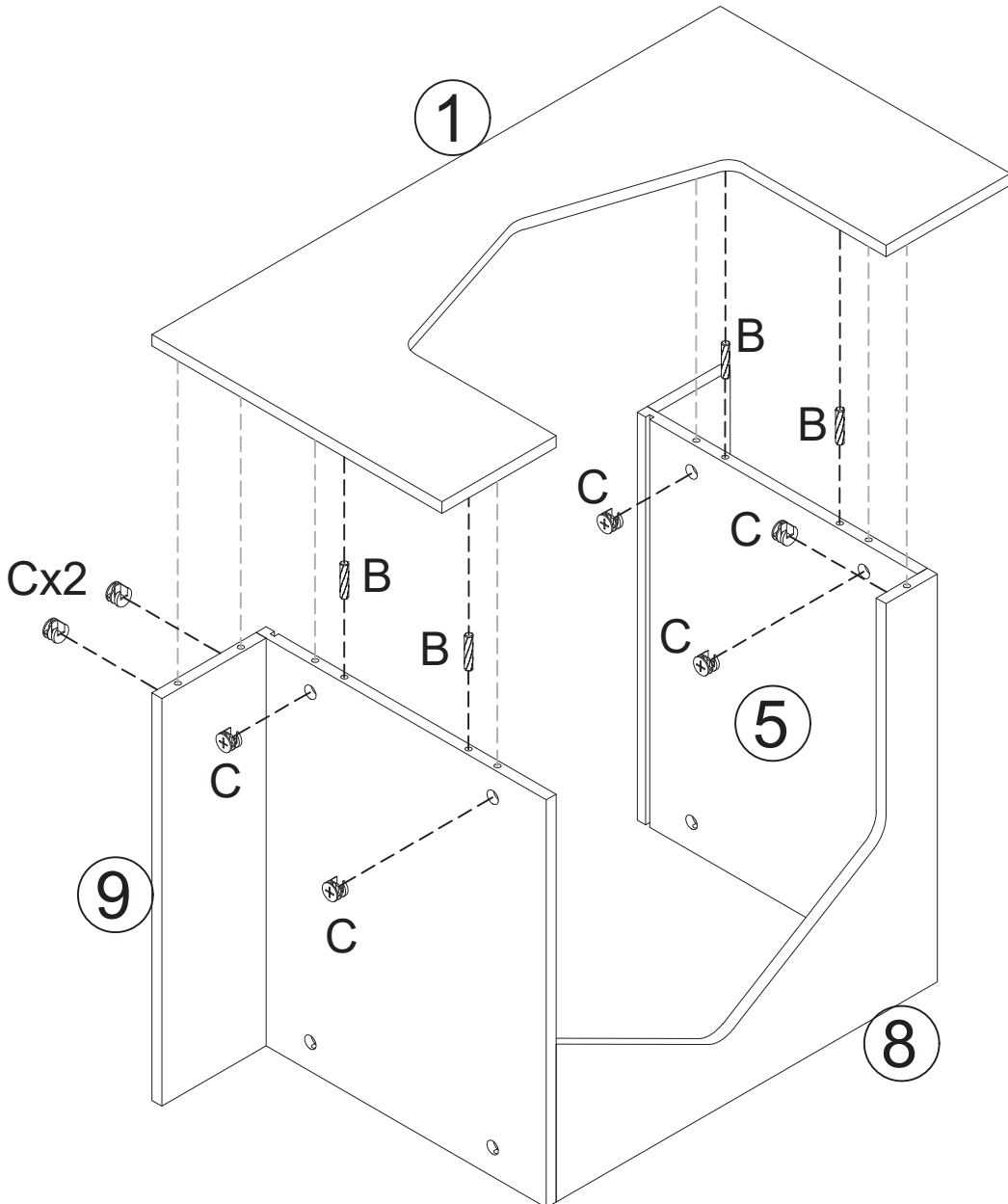

6

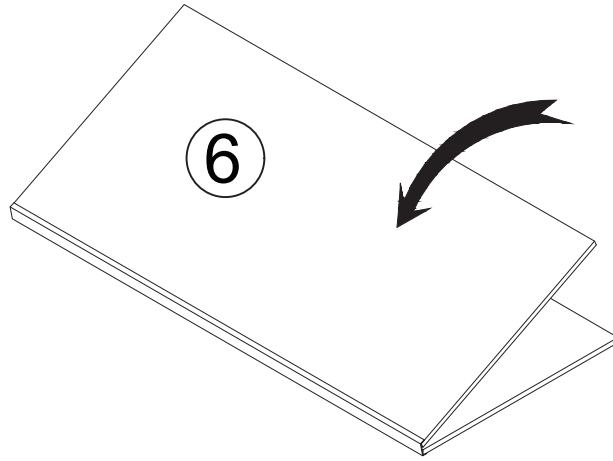



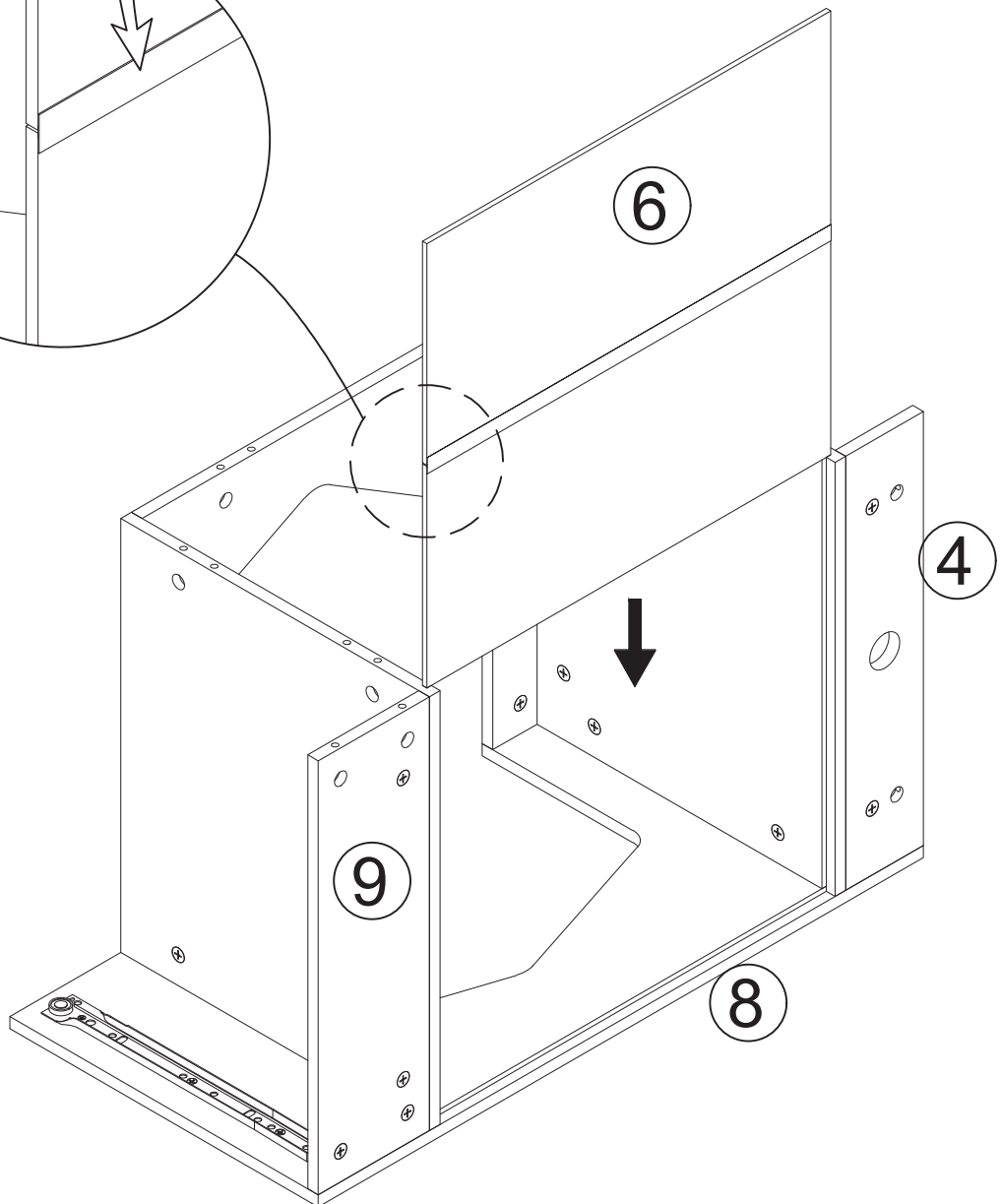
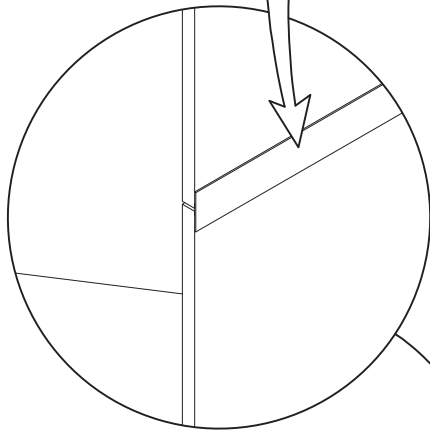

The taped side is facing outward

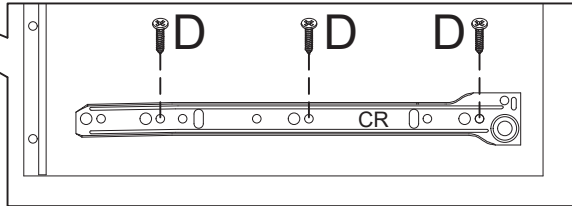
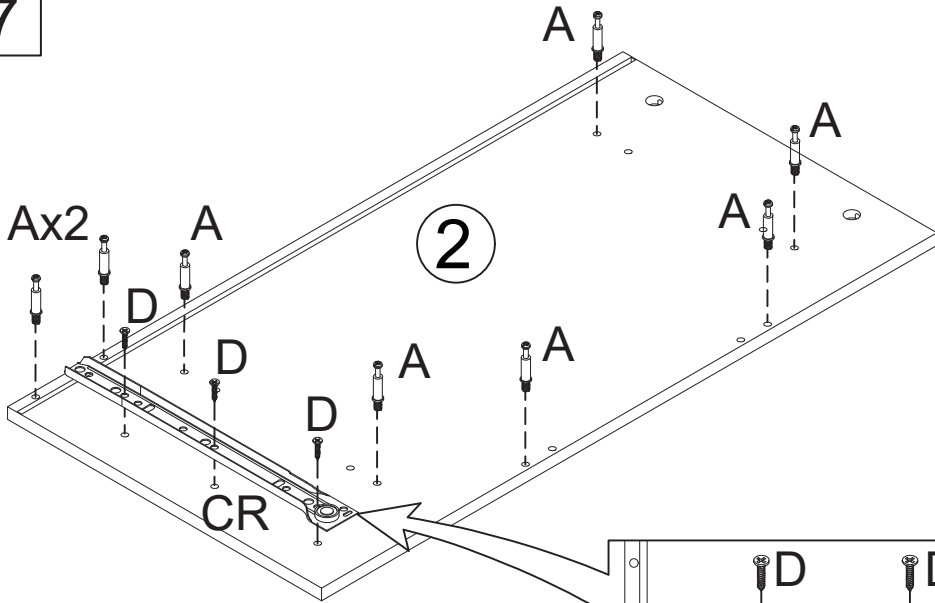

7



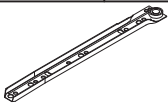

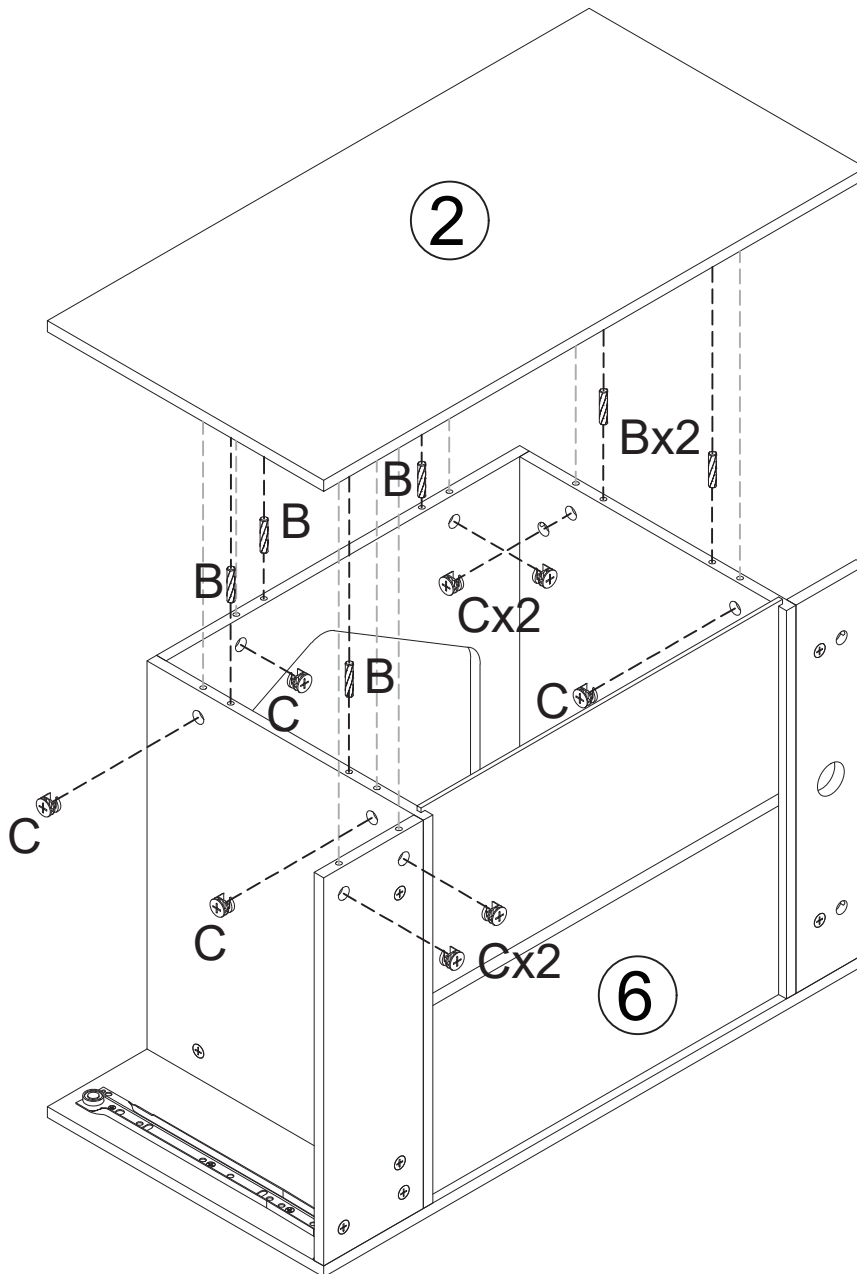
A	x8
	
B	x6
	
6x30mm	
C	x8
	
15x12mm	
D	x3
	
3x10mm	
CR	x1
	



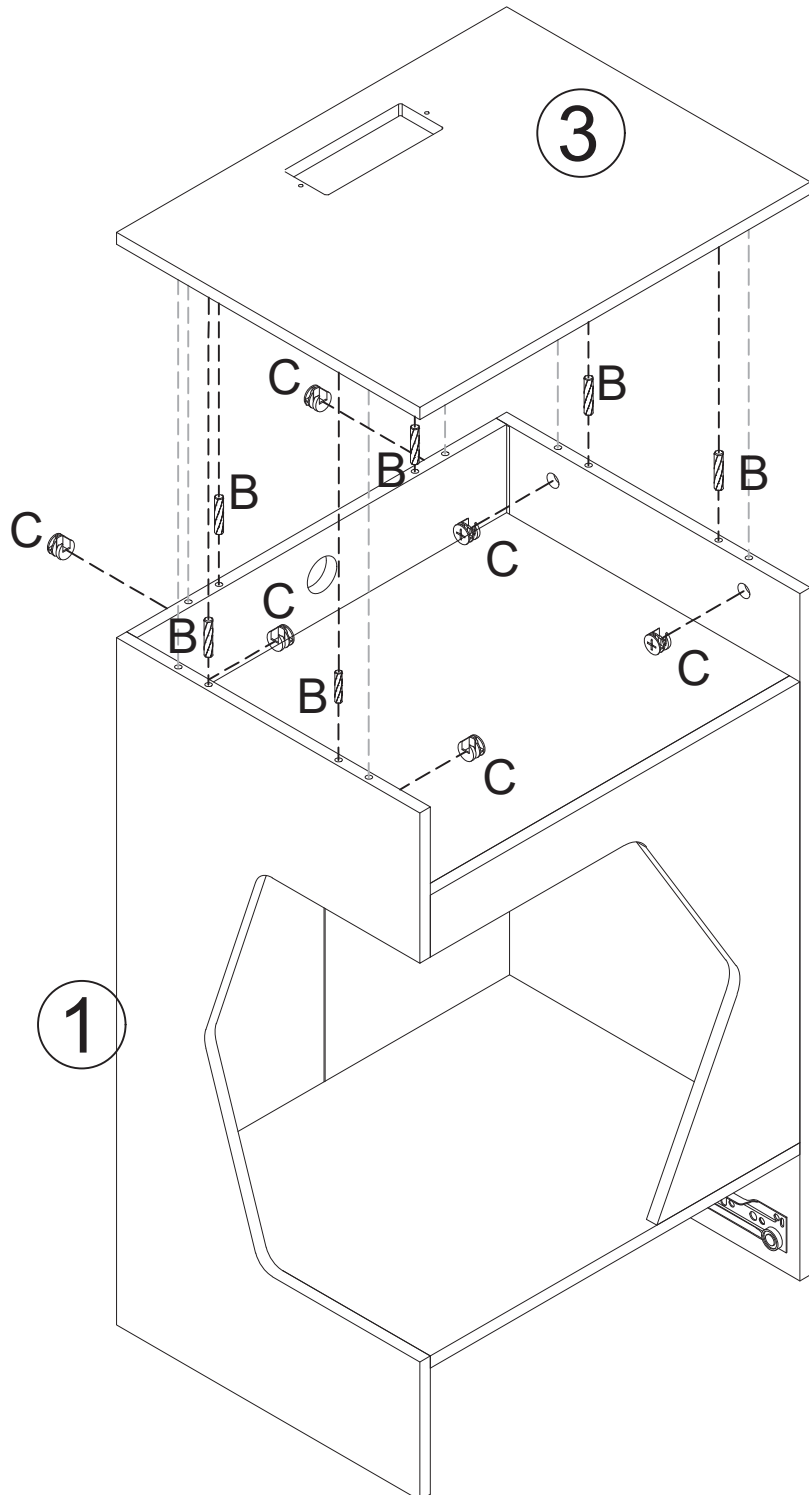
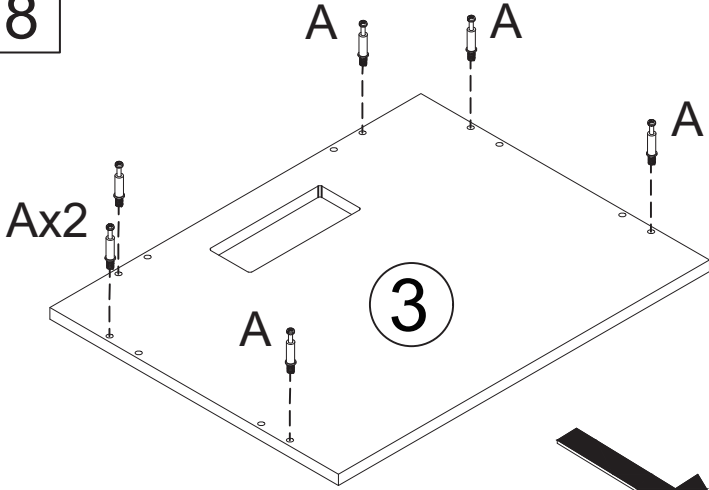



8



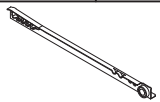
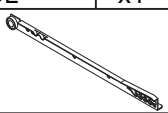

A	x6
	
B	x6
	
6x30mm	
C	x6
	
15x12mm	

9

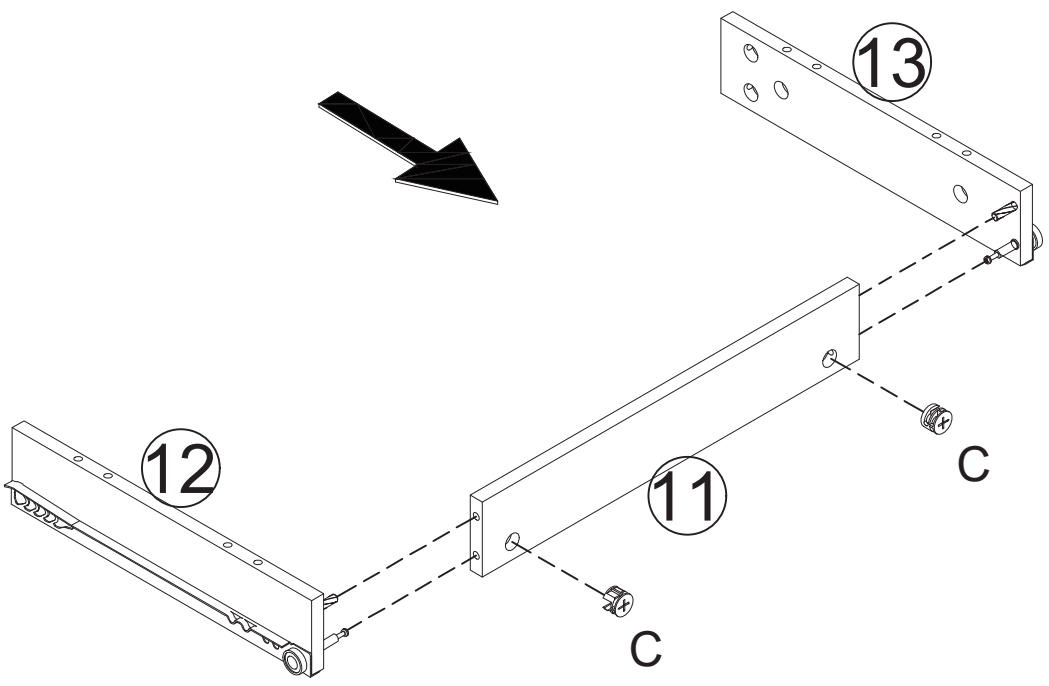
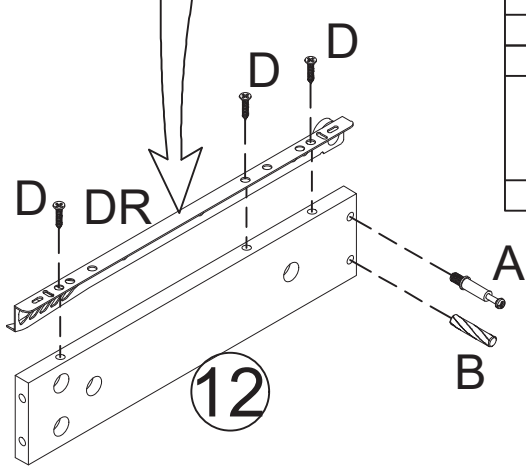
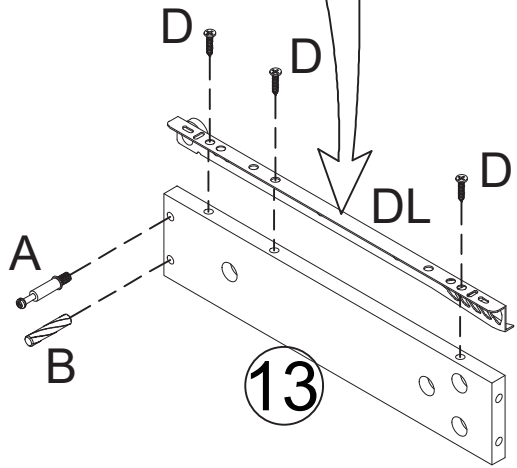
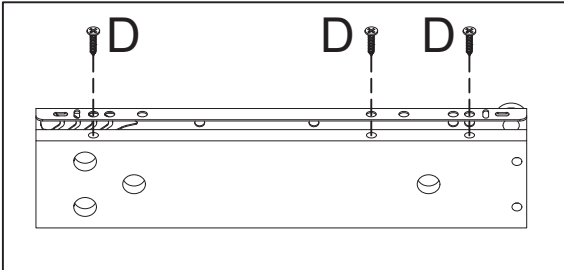
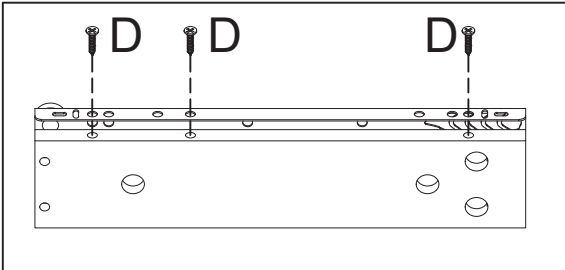
A	x2
	
B	x2
	
6x30mm	
C	x2
	
15x12mm	
D	x6
	
3x10mm	
DR	x1
	
DL	x1
	







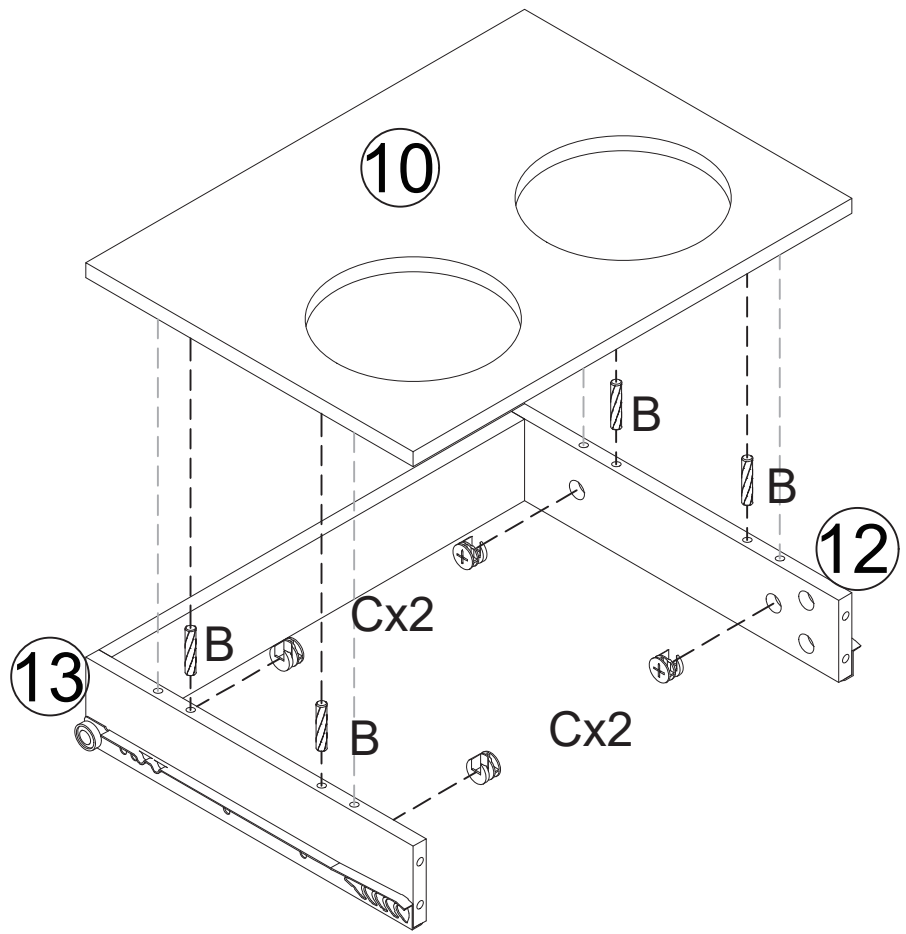
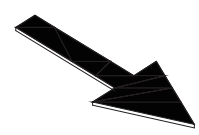
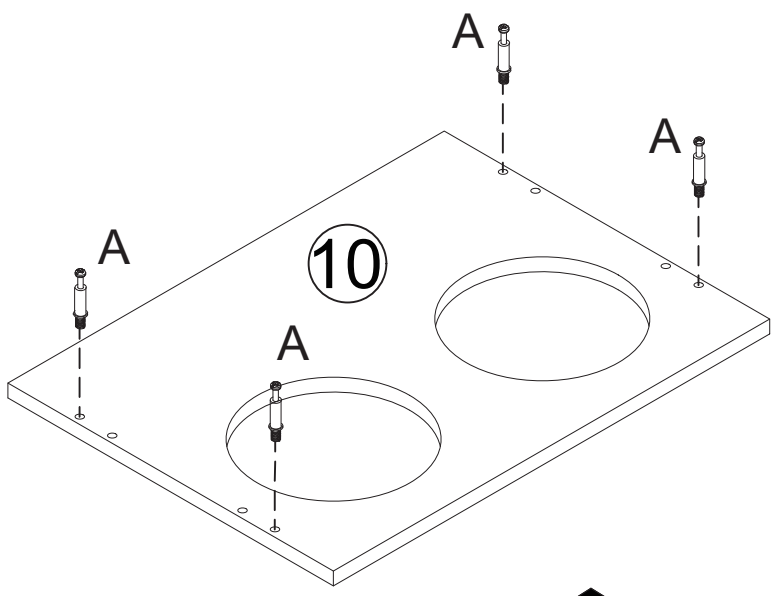

10

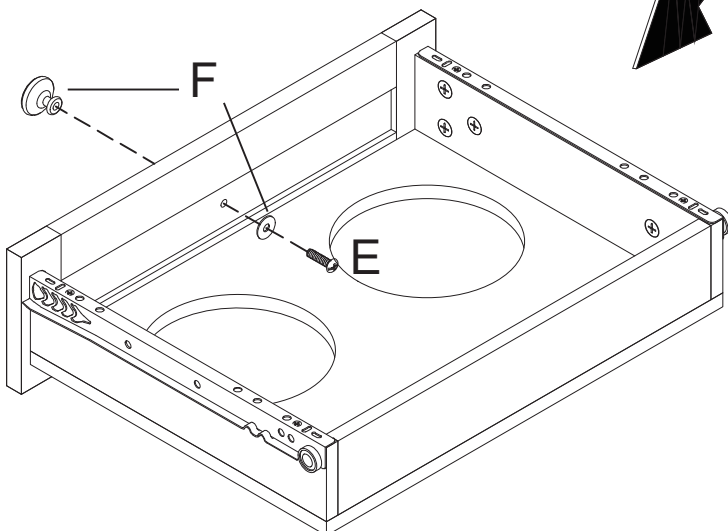
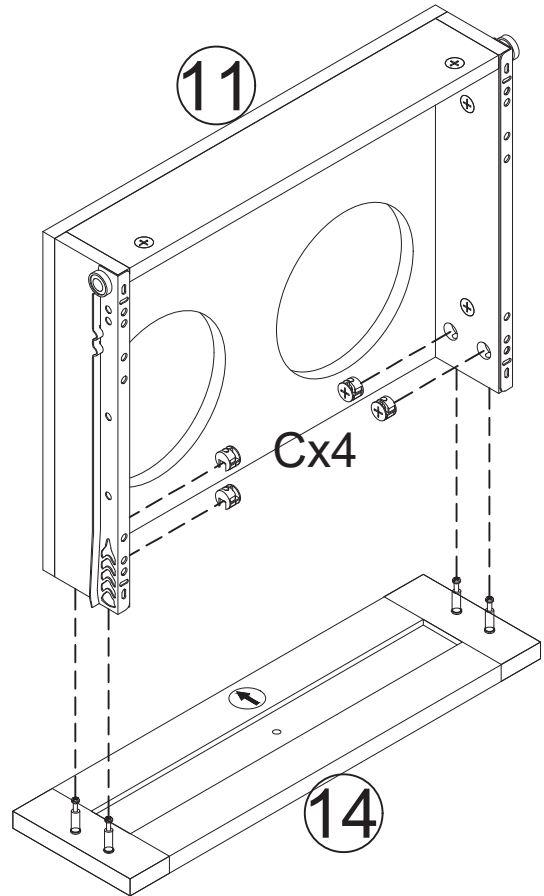
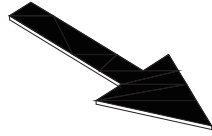
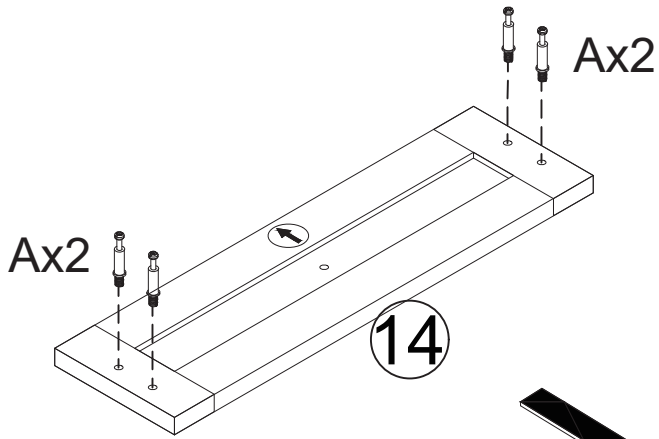
A	x4
	
B	x4
	
6x30mm	
C	x4
	
15x12mm	







11

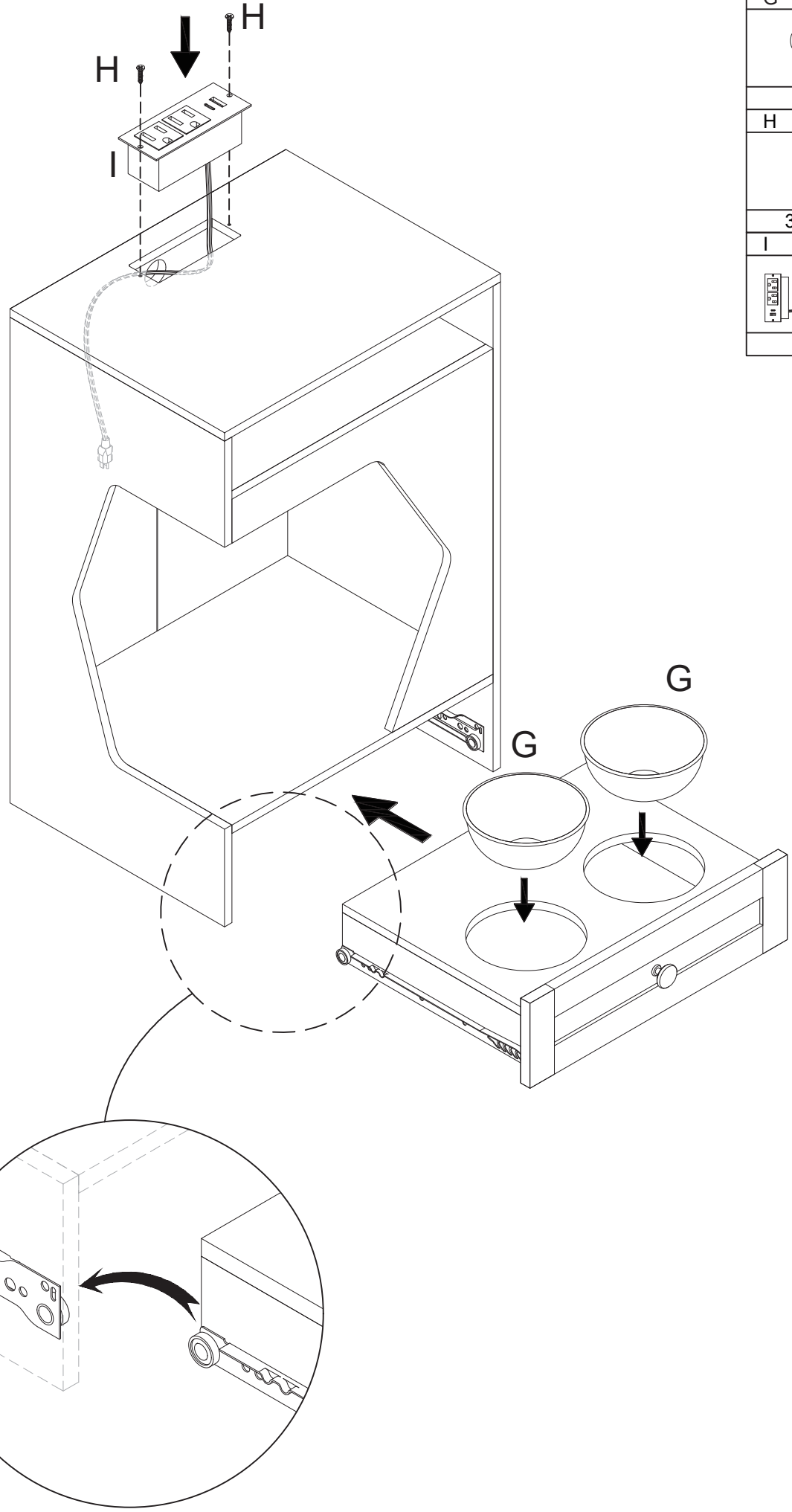

A	x4
	
C	x4
	
15x12mm	
E	x1
	
4x8mm	
F	x1
	
	

12



G	x2
	
H	x2
	
3x12mm	
I	x1
	

OPTION 1

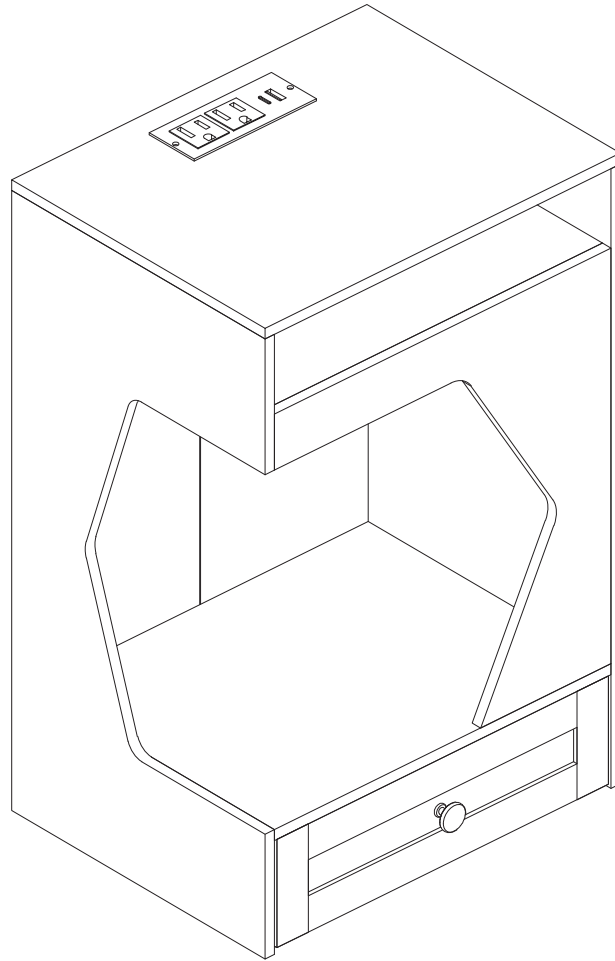

OPTION 2

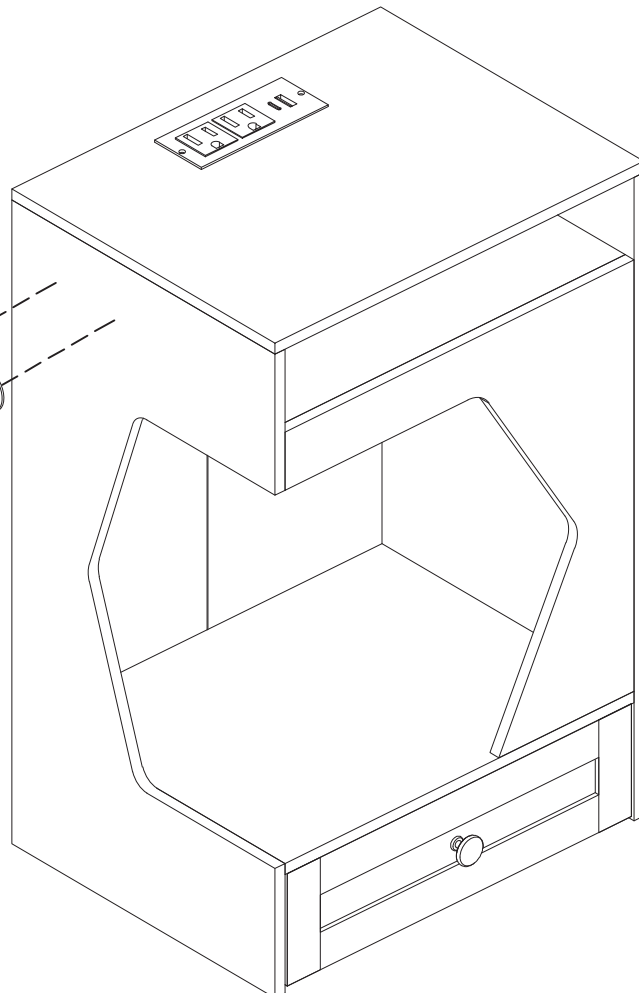
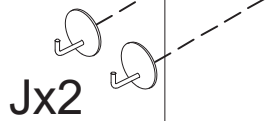

J	x2