

ASSEMBLY INSTRUCTIONS

TOOLS REQUIRED



Allen Wrench

(Included)

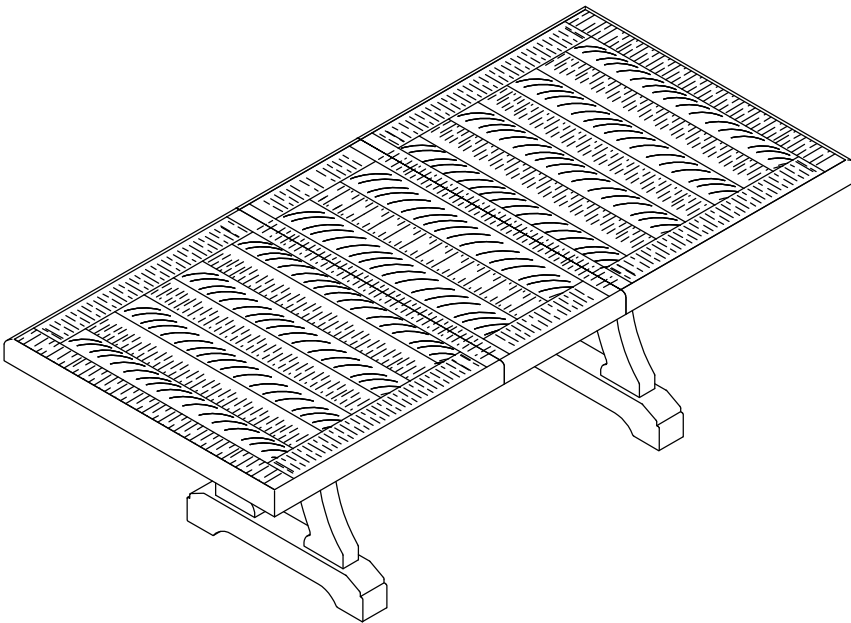

2 - People
Recommended

ASSEMBLY RATING



EASY —————▶ DIFFICULT

The Assembly Rating is a 5-point system showing the level of effort needed to assemble a specific product.

PRE ASSEMBLY INTRODUCTION

We understand building ready-to-assemble furniture can be a challenging experience for some. To help avoid confusion, we have provided some helpful tips that may speed up the process.



Teamwork

ALWAYS have at least two people to help with transporting and assembling the product to avoid potential injury and/or damage.



Suitable Location

Assembling near the area of the intended location is highly recommended.



Sufficient Space

Make sure you have enough space to move around during the assembly.

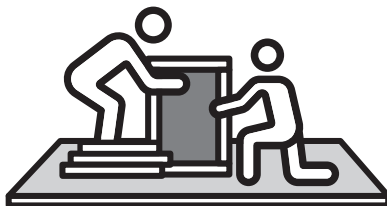

Avoid Scratches

Use cardboard, blankets or a carpeted area while assembling furniture to prevent scratches.

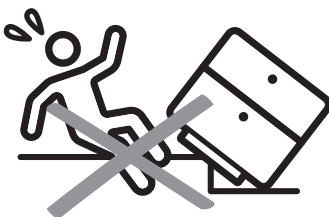

Flat Surface

Make sure the furniture rests on a flat and level surface with each leg evenly touching the floor.

ASSEMBLY AND CARE ADVICE



FAILURE TO FOLLOW THE GUIDELINES BELOW MAY RESULT IN INJURY AND/OR PROPERTY DAMAGE.



Position each part correctly and insert screws or bolts into their respective holes.



Turn clockwise to tighten and only tighten when step is completed or when instructed to do so.



Use the appropriate hand tools or power tools for assembly. Select steps, such as tightening screws and/or bolts, may require hand tools to avoid causing damage during assembly.



Save the instructions and store any supplied tools for later maintenance.



After two weeks, check and tighten any loose hardware and repeat again every six months thereafter.

IT IS THE USER'S RESPONSIBILITY TO MAINTAIN THE FURNITURE. THE HARDWARE MAY LOOSEN OVER TIME AND MAY CAUSE THE FURNITURE TO BE WOBBLY AND UNABLE TO SUPPORT ITS INTENDED WEIGHT CAPACITY. THIS MAY LEAD TO COLLAPSE AND MAY CAUSE SERIOUS INJURY.

TABLE



- Please keep instructions for future reference.
- Check the quantity and irregularity of parts and hardware before you start.

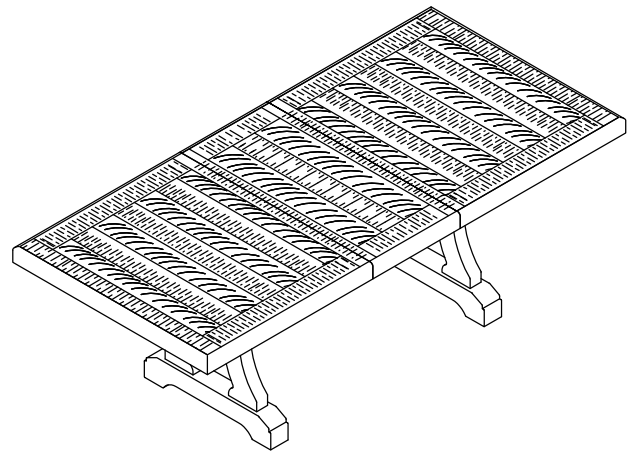

PARTS

#1 1pc



Table Top

#2 1pc



Leaf

#3 2pcs

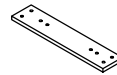

Mounting Plate

#4 1pc

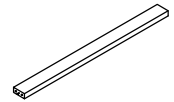

Stretcher

#5 2pcs



Wooden Plug

#6 2pcs

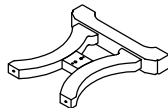

Legs

HARDWARE

#A 12pcs



Bolt Ø5/16" x2-3/8"

#B 8pcs



Bolt Ø5/16" x 1-5/8"

#C 20pcs



Lock Washer
Ø5/16"x13mm

#D 20pcs









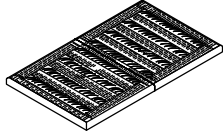

Flat Washer
Ø5/16"x19mm

#E 1pc

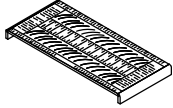
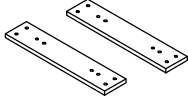

Allen Wrench M4

packed in 2 cases

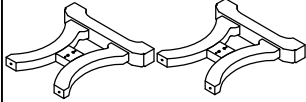
Carton	Disignation	Part		Hardware
1	Table Top	#1		 #A x 12pcs  #B x 8pcs  #C x 20pcs  #D x 20pcs  #E x 1pc
	Leaf	#2		
	Mounting Plate	#3		
	Stretcher	#4		
	Wooden Plug	#5		
2	Legs	#6		

Exploded View

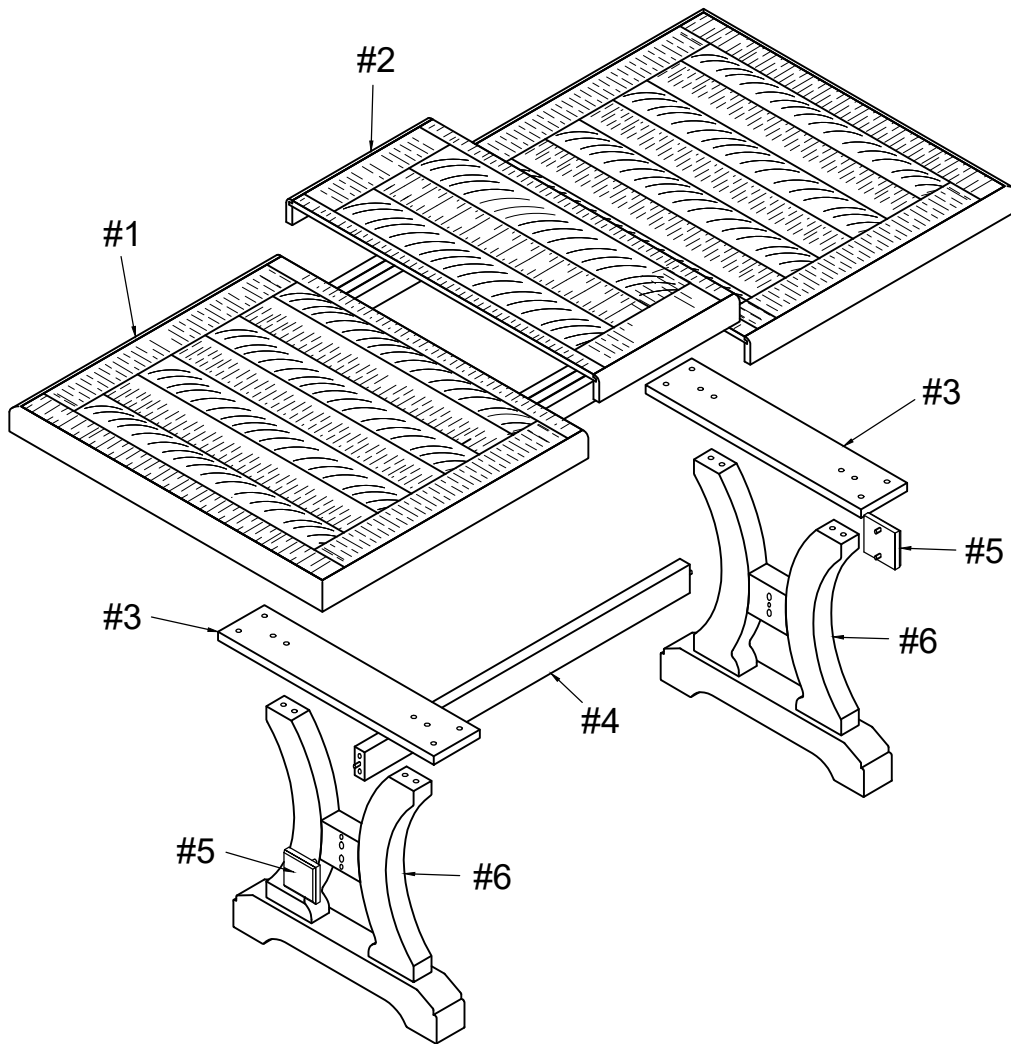

ASSEMBLY INSTRUCTIONS

1

Part #3 x2pcs

Part #6 x2pcs

Hardware #A x8pcs

Hardware #C x8pcs

Hardware #D x8pcs

Align mounting plate (#3) to the legs (#6), then secure by using bolts (#A) with washers (#C,D).

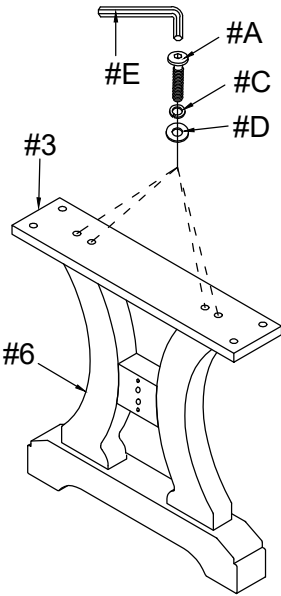

2

Part #4 x1pc

Part #5 x2pcs

Hardware #A x4pcs

Hardware #C x4pcs

Hardware #D x4pcs

Align stretcher (#4) to the legs, then secure by using bolts (#A) with washers (#C,D). Place cover (#5) to cover the bolts (#A).

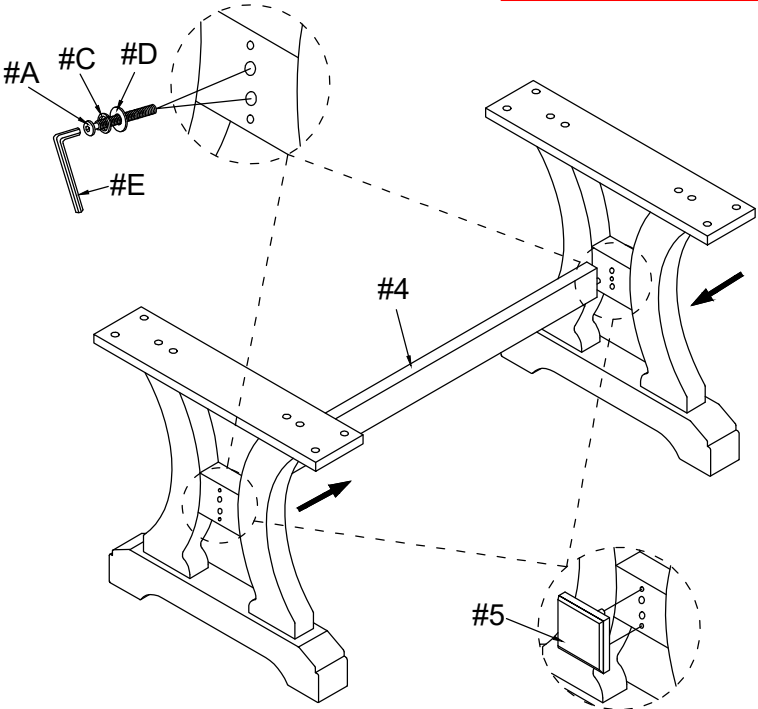

ASSEMBLY INSTRUCTIONS

3

- Part #1 x1pc
- Hardware #B x8pcs
- Hardware #C x8pcs
- Hardware #D x8pcs

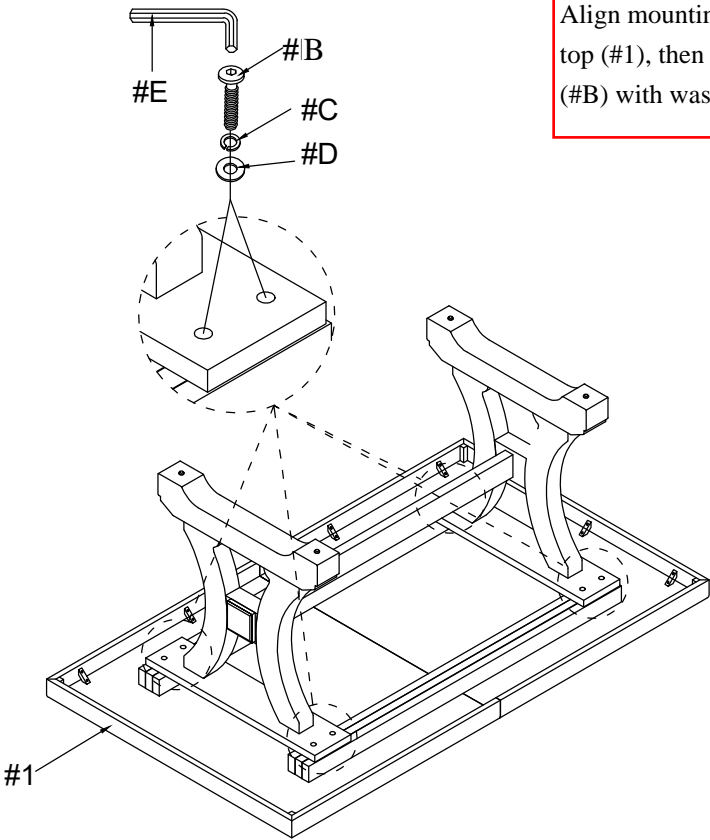

4

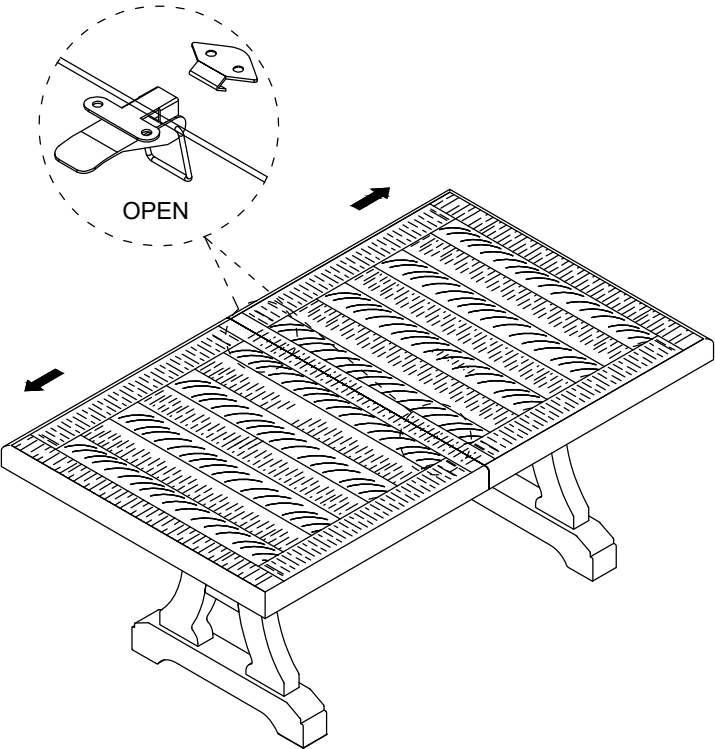

ASSEMBLY INSTRUCTIONS

5

Part #2 x1pc

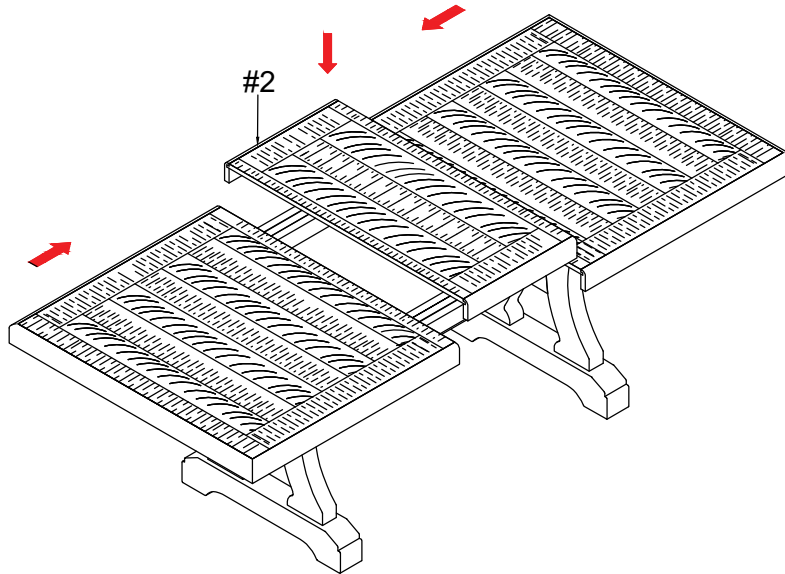

6

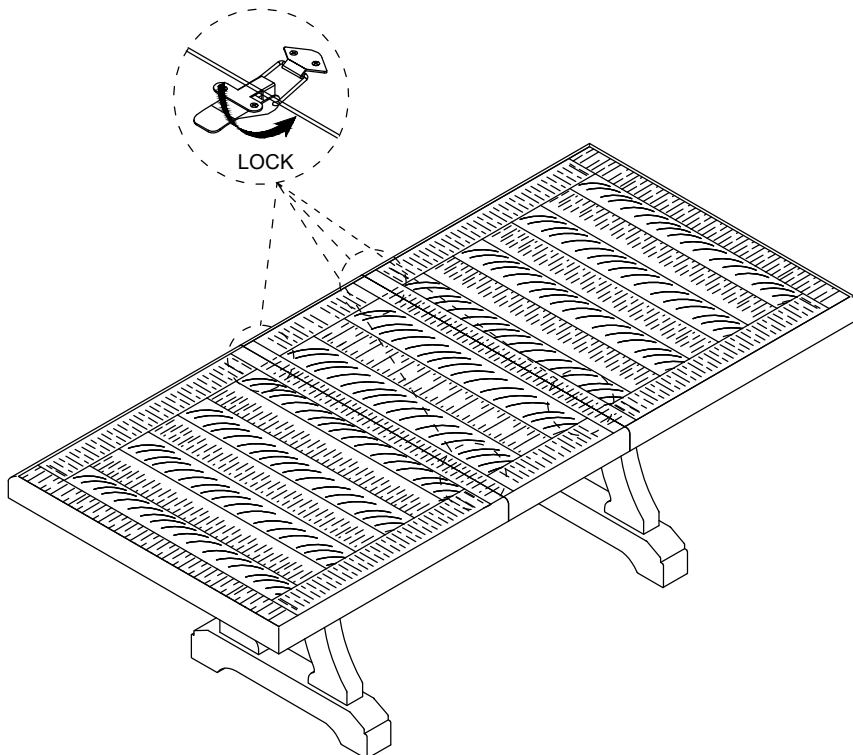

ASSEMBLY COMPLETED

Please ensure the furniture rests on an even and flat surface. If the product wobbles or feels loose, double-check all bolts and/or screws are properly tightened and secured.



Keep this handy!

Please retain this instruction manual and any order-related information for future reference.

Lift, don't drag!

To avoid damage to product please always LIFT the product when transporting or adjusting the placement.