

ASSEMBLY INSTRUCTIONS

118-915 END TABLE

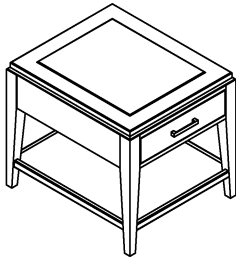

118-915

IMPORTANT NOTES :

- . Place all parts on the clean and smooth surface such as a rug or carpet to prevent the parts from being scratched.
- . Check to be sure that you have all parts and hardware.
- . Remove all wrapping materials, including staples and packing straps before you start to assemble.
- . Do not tighten all screws and bolts until completely assembled.
- . Keep all hardware out of the reach of children.

Caution: Do not over tighten any bolts during assembly.

1. Turn the table upside down on a clean soft surface.
2. Attach 2 legs of front side to the table top using the Nuts (A), Flat washers (C), Spring washers (D) and tighten with the Wrench (F) (as shown Fig.1).
3. Attach the wood shelf to the assembled legs using the Brackets (G), Bolts (B), Spring washers (D), Flat washers (C) and tighten with the Allen wrench (E) (as shown Fig.2 & Fig.3).
4. Attach other 2 legs to the table top using the Nuts (A), Flat washers (C), Spring washers (D) and tighten with the Wrench (F) (as shown Fig.4).
5. Attach the wood shelf to other legs using the Brackets (G), Bolts (B), Spring washers (D), Flat washers (C) and tighten with the Allen wrench (E) (as shown Fig.5 & Fig.6).
6. Open the drawers, unscrew the handles inside and attach it outside of drawers panel (as shown Fig.7).

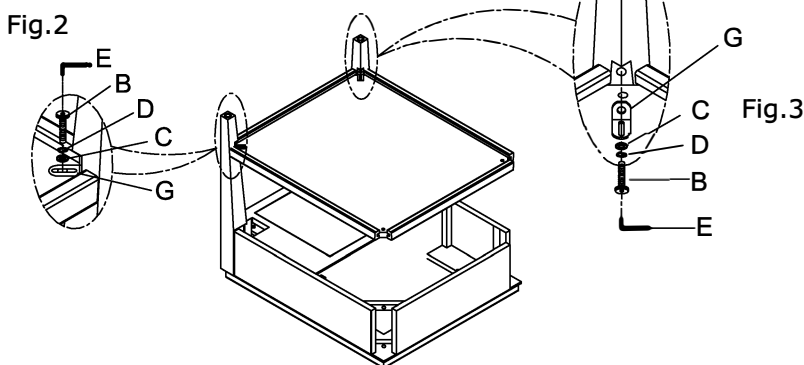
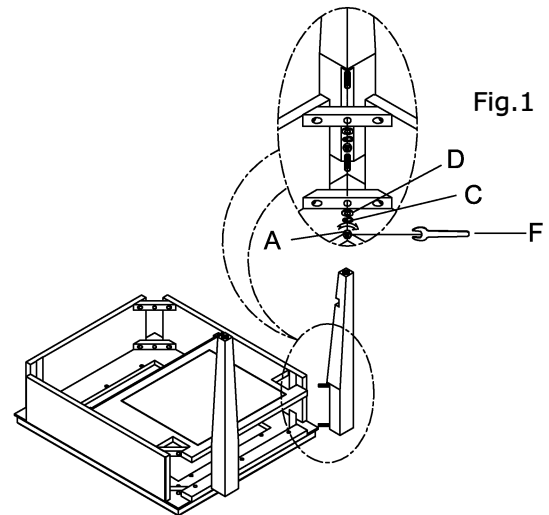

HARDWARE LIST			
ITEM	DRAWING	DESCRIPTION	Q' TY
A		Nut (Ø1/4"*5mm)	8PCS
B		Bolt (Ø1/4"*5/8")	8PCS
C		Flat Washer (Ø1/4"*Ø16mm)	16PCS
D		Spring Washer (Ø1/4")	16PCS
E		Allen Wrench(4mm)	1PC
F		Wrench (14mm)	1PC
G		Bracket (32/22*18*2mm)	4PCS

MADE IN VIETNAM

ASSEMBLY INSTRUCTIONS

118-915 END TABLE

