



For a Hassle-Free Installation

1. Ensure you have received all cartons and familiarize yourself with the workload. Make sure there are enough helping hands to assist you, and that you have allocated the time required to assemble your new product.
2. Make sure you have cleared enough space in your home for the assembly. We recommend protecting your floor with a mat or cardboard to avoid scratches during the assembly process.
3. Read instructions carefully and check no parts are missing.
4. Lay out all hardware on a soft surface so you can easily identify them.
5. Carefully identify all components according to the labeled alphabet to ensure that the parts are in the correct place.
6. Install your new product carefully following the instructions. Don't skip ahead!

* If any parts are missing or damaged, we will gladly ship you replacement parts free of charge. Please contact us order ID and the Store Name of your purchase, we're always here to help :)

WARNING

Serious or fatal injury may occur from unexpected assembly or use.

1. During the assembly process, keep all parts away from babies or children.
2. Always securely fix this product to the wall. Make sure the wall area to be drilled is free from hidden electrical wires, water and gas pipes.
3. Use of tip-over restraints may only reduce, but not eliminate the risk of tip-over.
4. Unless specially designed to accommodate, do not set heavy objects on top of this product.
5. Place the heaviest items on the lowest shelf.
6. Never allow children to climb or bang on drawers, doors or shelves.

WARNING



Children have died from furniture tipover. To reduce the risk of furniture tipover:

- **ALWAYS** install tipover restraint provided.
- **NEVER** put a TV on this product.
- **NEVER** allow children to stand, climb or hang on drawers, doors, or shelves.
- **NEVER** open more than one drawer at a time.
- Place heaviest items in the lowest drawers.



Parts List

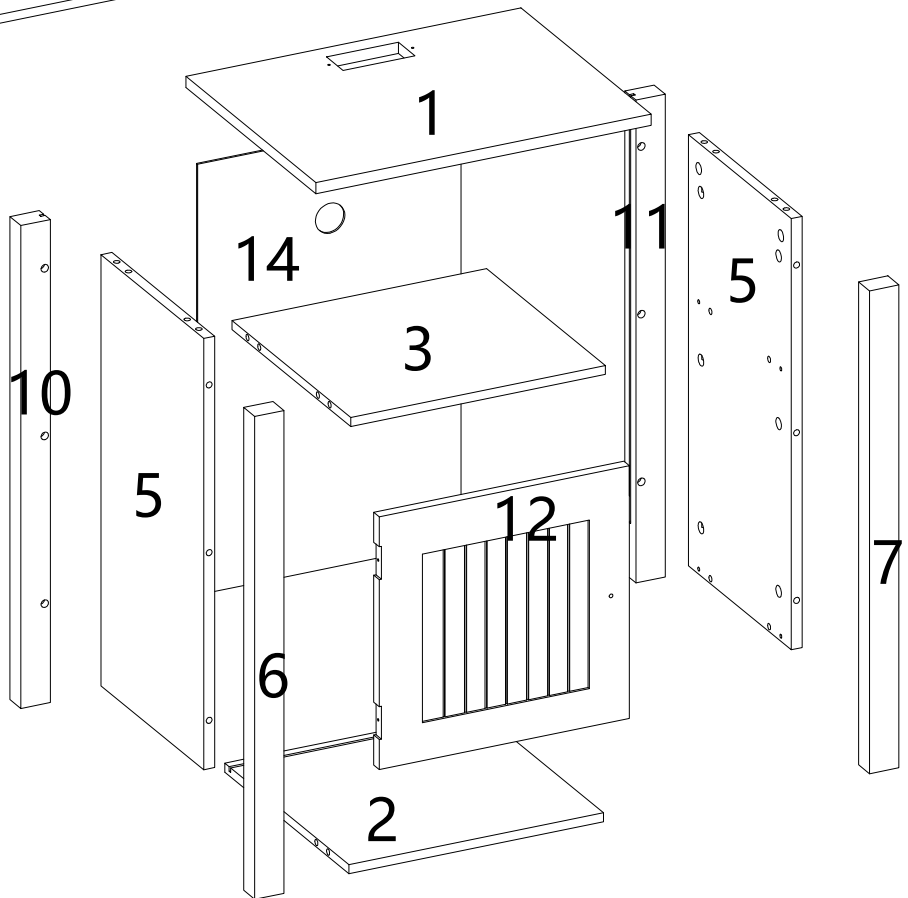
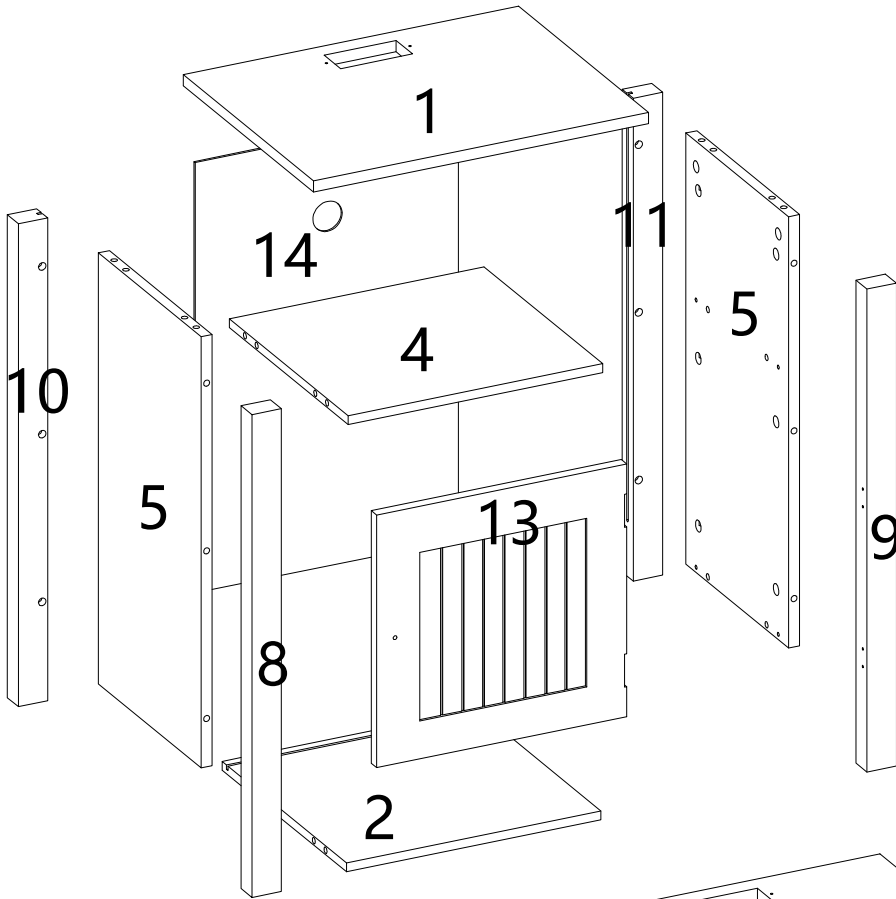

Please don't install it until you received both packages.



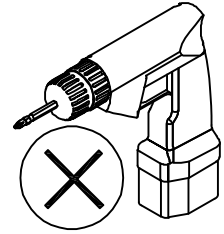
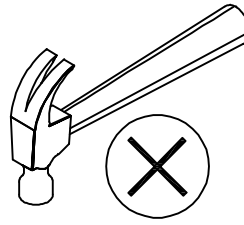
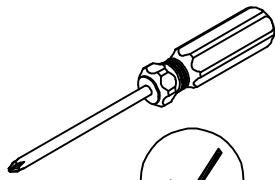
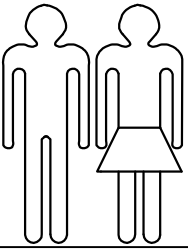

Parts List

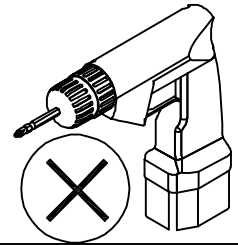
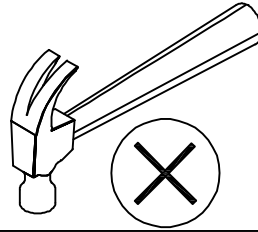
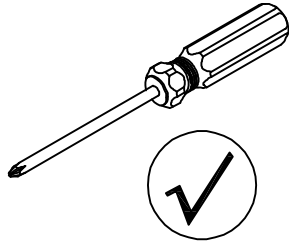
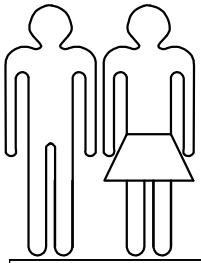

<p>1</p> <p>the other side</p> <p>one side</p> <p>457*355*15mm 2PCS</p>	<p>2</p> <p>the other side</p> <p>one side</p> <p>347*339*12mm 2PCS</p>	<p>3</p> <p>347*323.5*12mm 1PC</p>	
<p>4</p> <p>347*323.5*12mm 1PC</p>	<p>5</p> <p>576*280*15mm 4PCS</p>	<p>6</p> <p>645*40*30mm 1PC</p>	<p>7</p> <p>645*40*30mm 1PC</p>
<p>8</p> <p>645*40*30mm 1PC</p>	<p>9</p> <p>the other side</p> <p>one side</p> <p>645*40*30mm 1PC</p>	<p>10</p> <p>the other side</p> <p>one side</p> <p>645*40*30mm 2PCS</p>	<p>11</p> <p>the other side</p> <p>one side</p> <p>645*40*30mm 2PCS</p>
<p>12</p> <p>the other side</p> <p>one side</p> <p>337.5*341*15mm 1PC</p>	<p>13</p> <p>the other side</p> <p>one side</p> <p>337.5*341*15mm 1PC</p>	<p>14</p> <p>573*357*3mm 2PCS</p>	

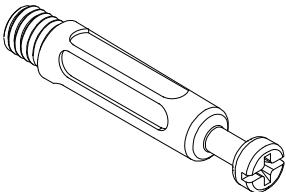
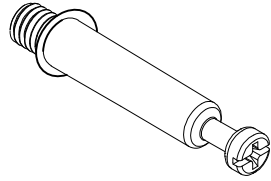
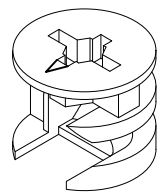
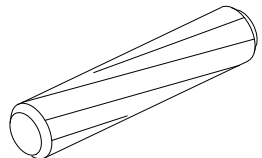
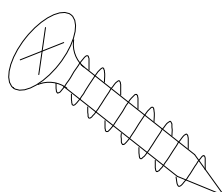
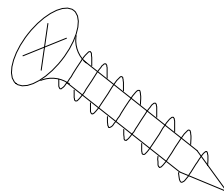
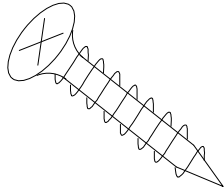
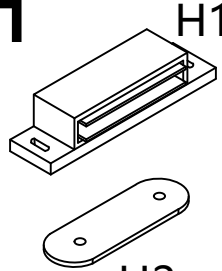
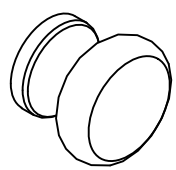
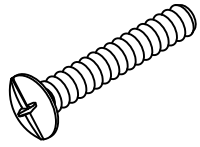
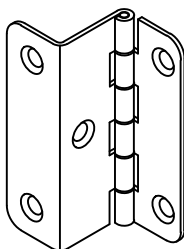
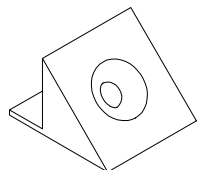
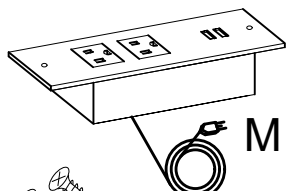
Hardware List

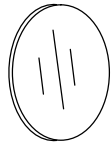
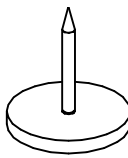

<p>A</p>  <p>ø7*40mm 32PCS</p>	<p>B</p>  <p>ø7*40mm 16PCS</p>	<p>C</p>  <p>ø15*9.5mm 48PCS</p>	<p>D</p>  <p>ø8*30mm 24PCS</p>
<p>E</p>  <p>ø3*12mm 4PCS</p>	<p>F</p>  <p>ø3.5*14mm 40PCS</p>	<p>G</p>  <p>ø3*16mm 4PCS</p>	<p>H</p>  <p>H1 H2 2PCS</p>
<p>I</p>  <p>ø30*26mm 2PCS</p>	<p>J</p>  <p>M4*18mm 2PCS</p>	<p>K</p>  <p>42*20*20mm 4PCS</p>	<p>L</p>  <p>13.5*13*10mm 20PCS</p>
<p>M</p> <p>124*47*48mm</p>  <p>M1</p>  <p>M2 ø3.5*14mm 2PCS</p>	<p>N</p>  <p>ø21mm 40PCS</p>	<p>O</p>  <p>ø13.5mm 4PCS</p>	<p>Spare plastic hardware</p>  <p>X4 ø5*10mm</p>

Assembly

CAM BOLT INSTALLATION AS BELOW:

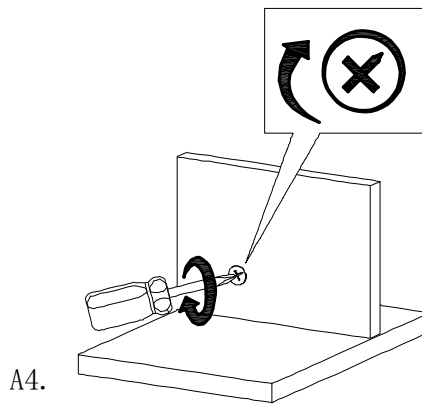
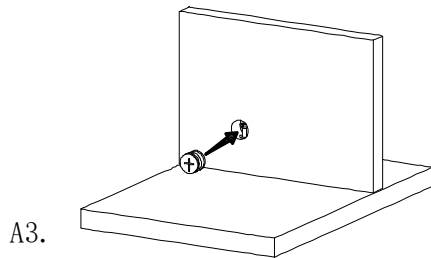
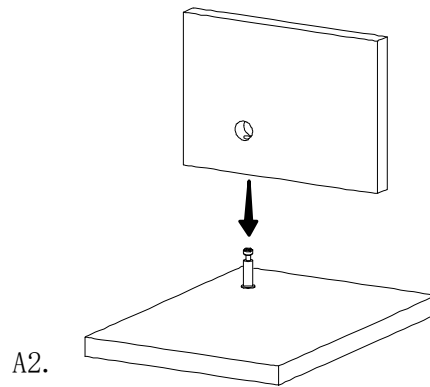
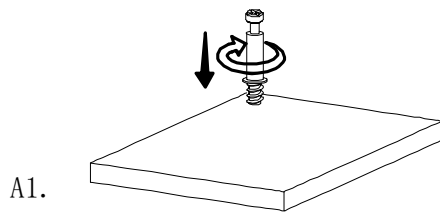
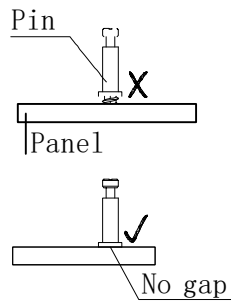
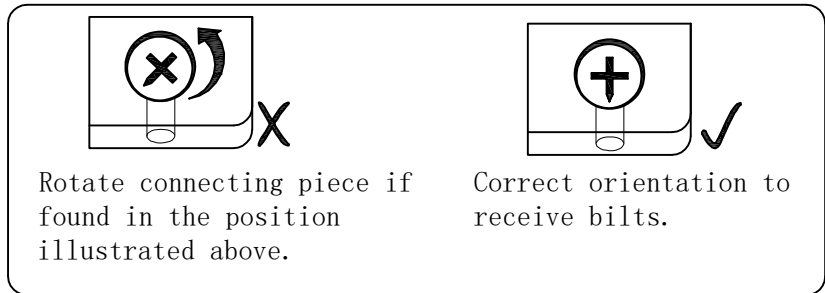
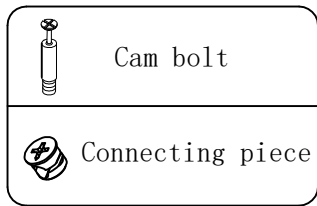

Assembly

STEP 1

X4

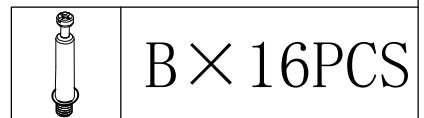
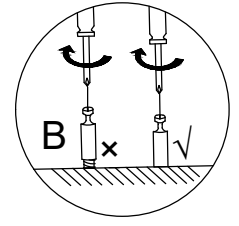
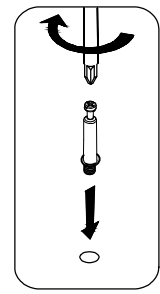
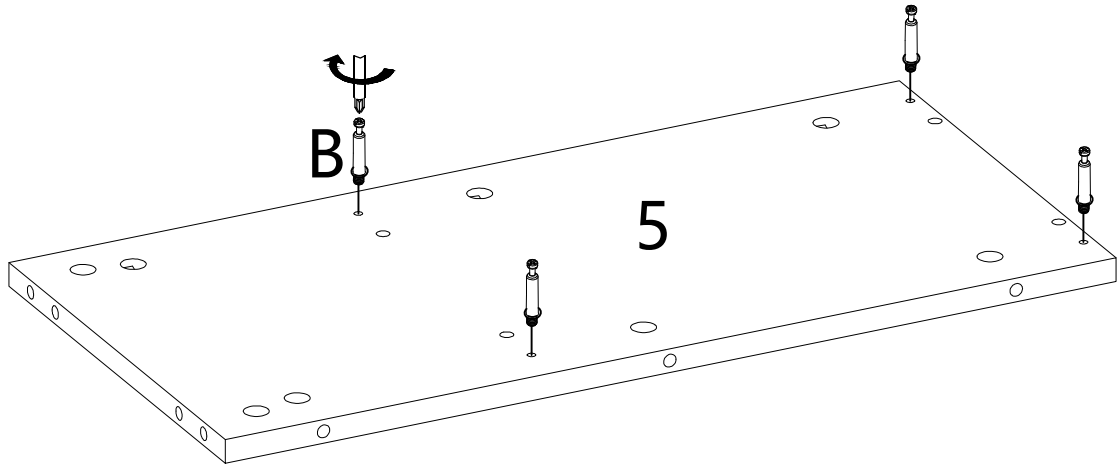

STEP 2

X2

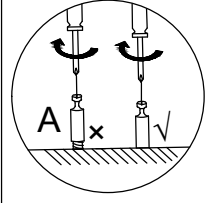
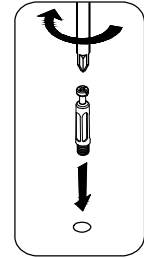
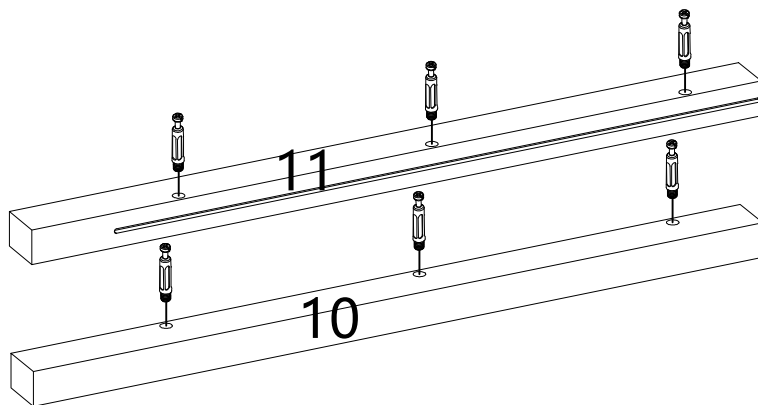

Assembly

STEP 3

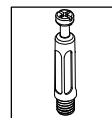
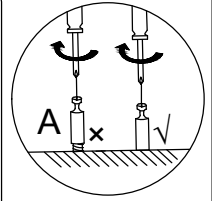
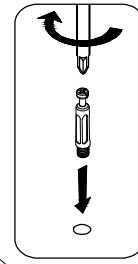
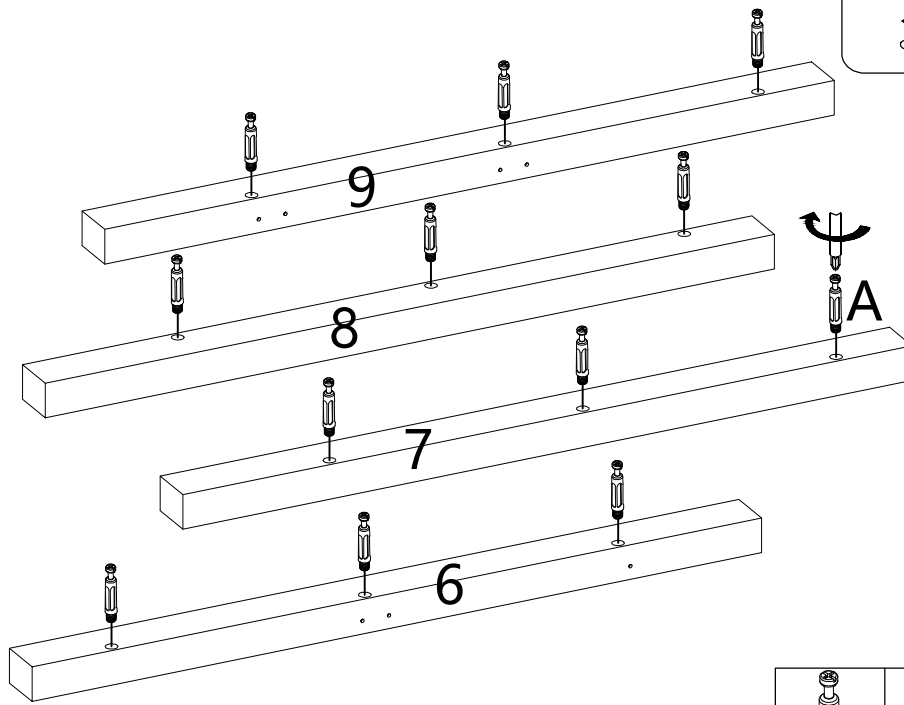

A × 12PCS

STEP 4

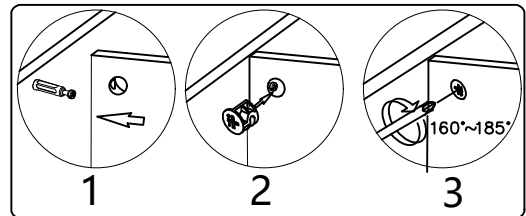
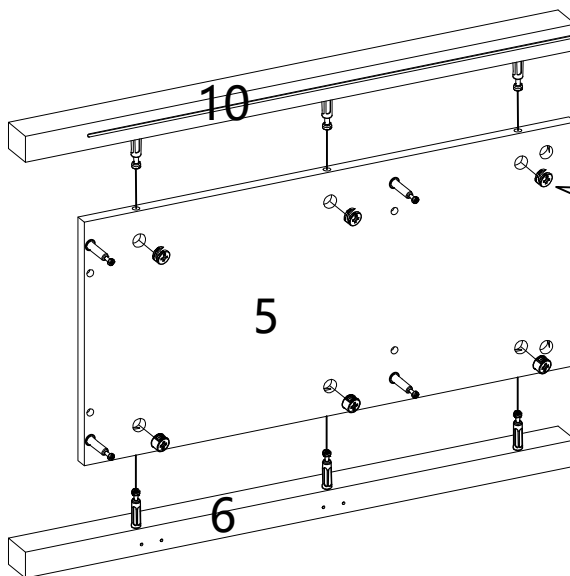

C × 6PCS

Assembly

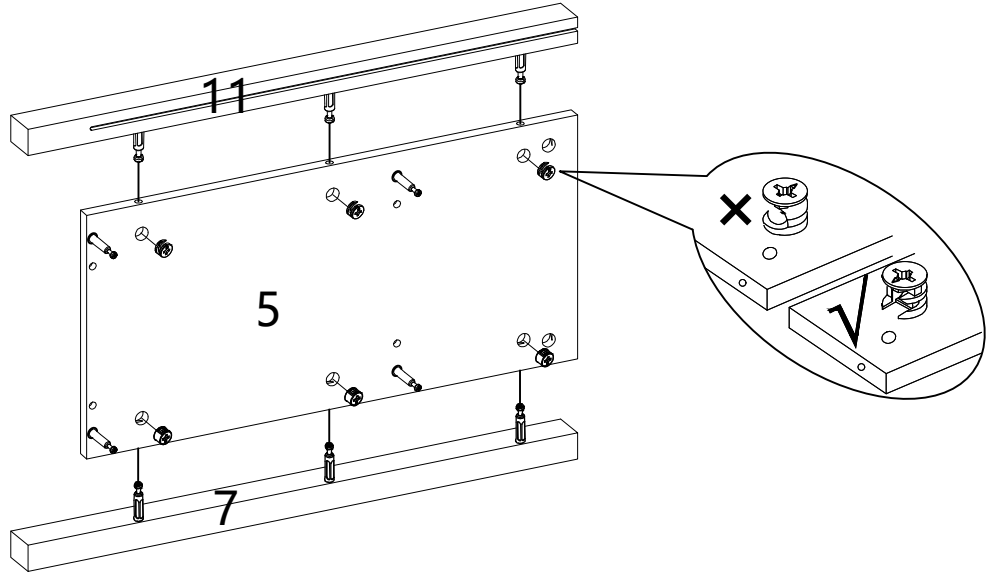
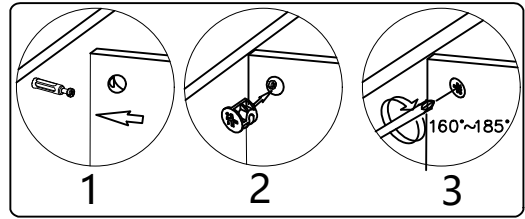

STEP 5

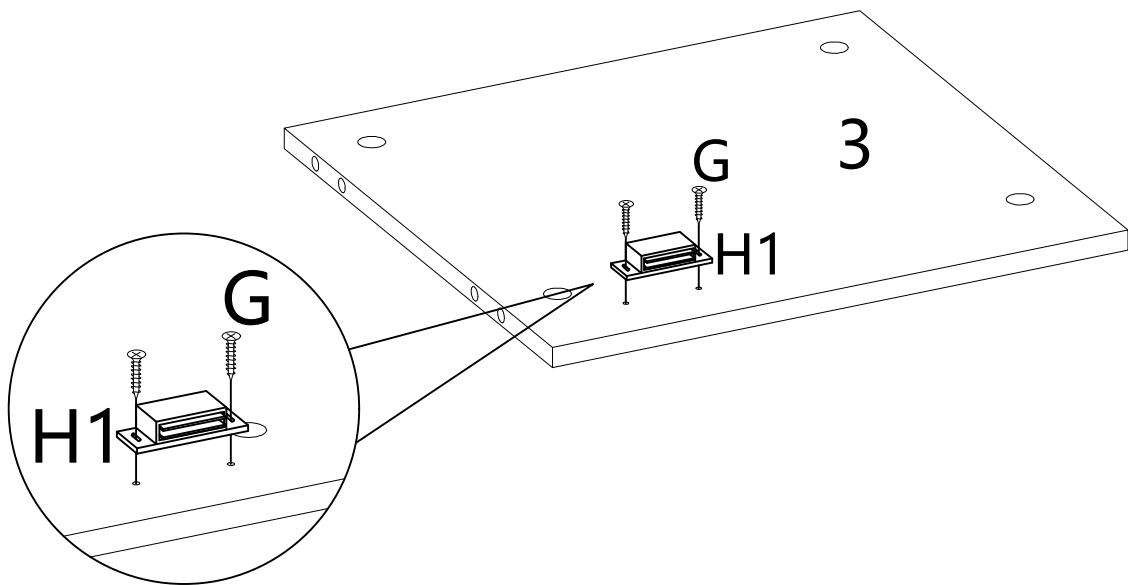

	C × 6PCS
---	----------

STEP 6



	H1 × 1PC
	G × 2PCS

Assembly

STEP 7

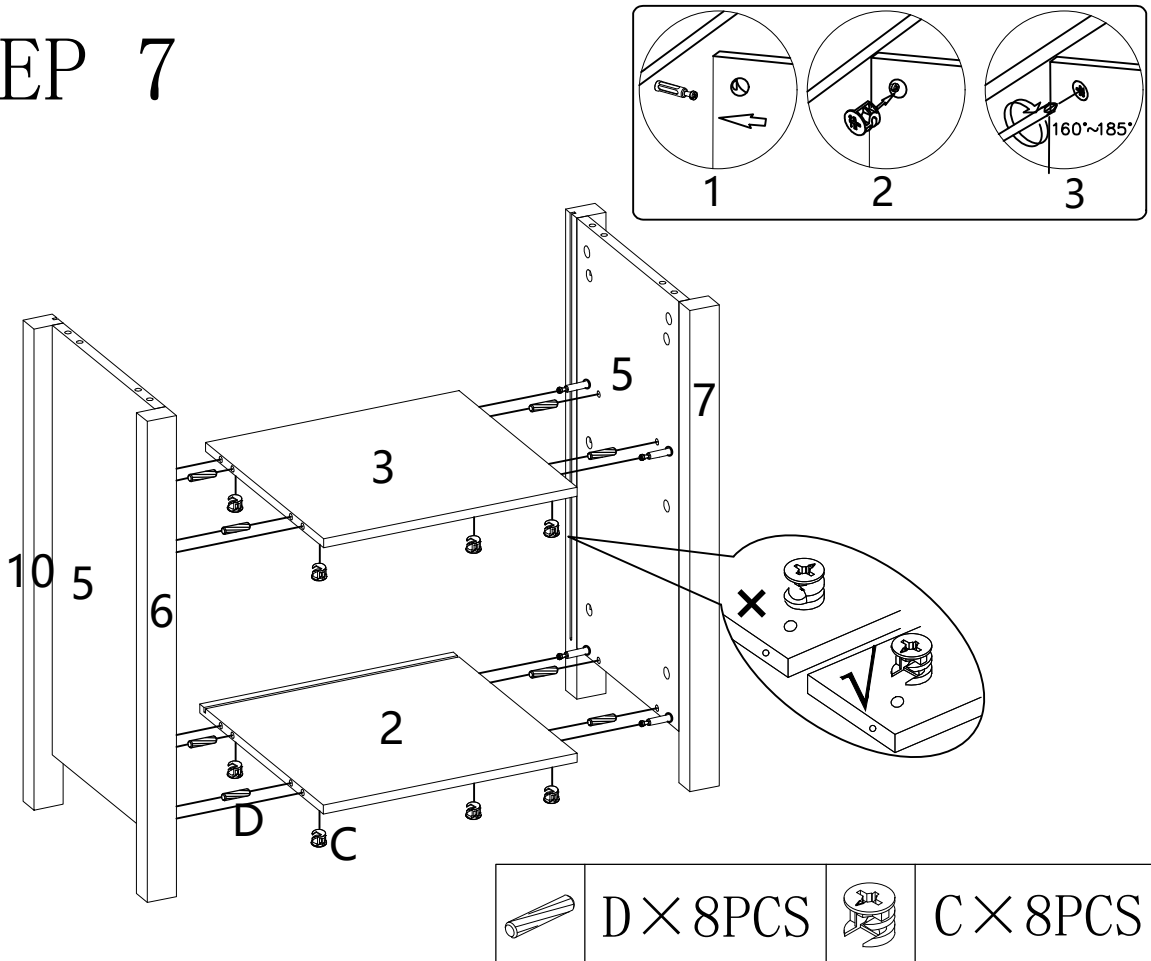

STEP 8

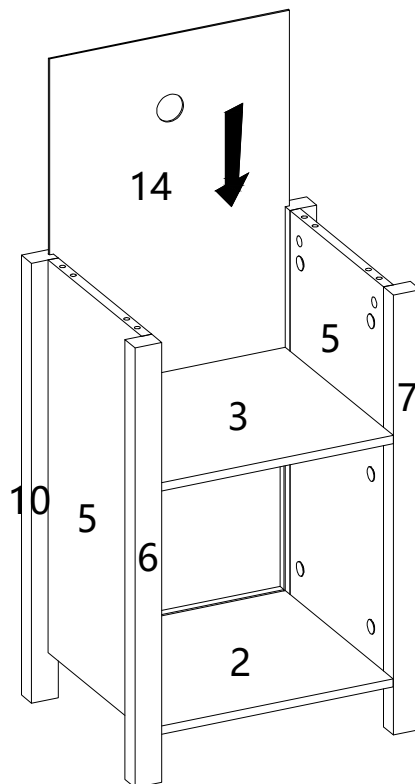

The thin backing plate must be located in the slot or it will block the opposite plate.

Assembly

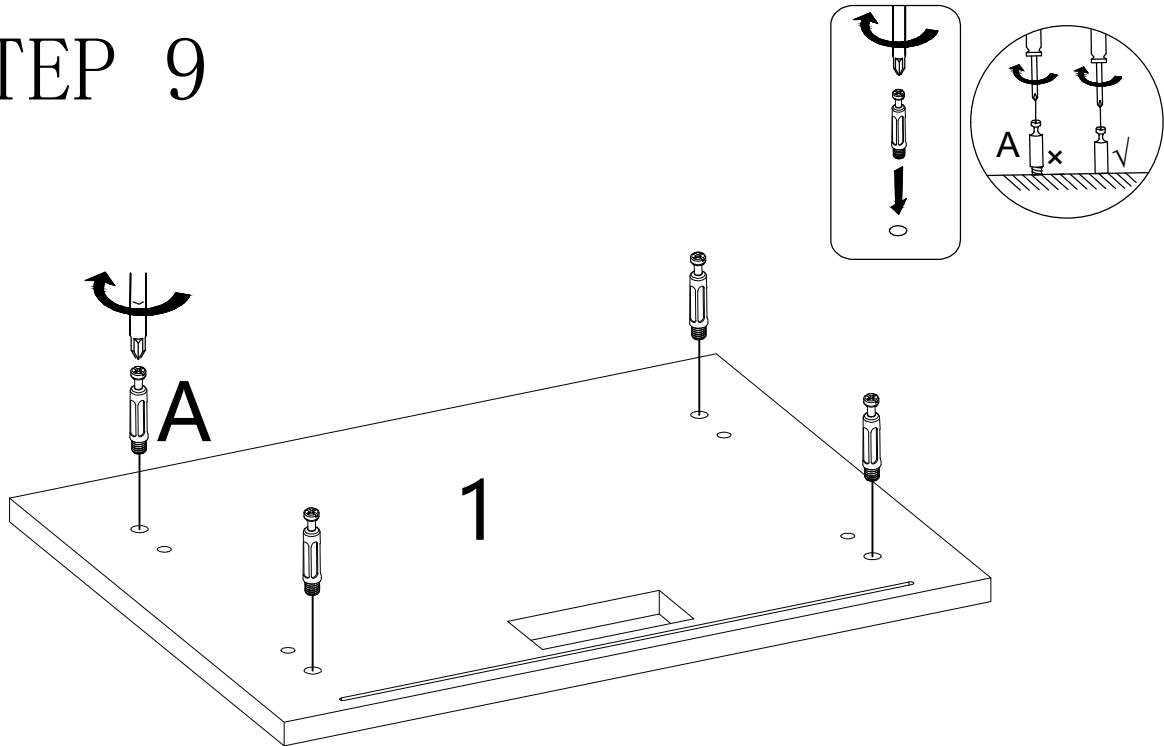

STEP 9

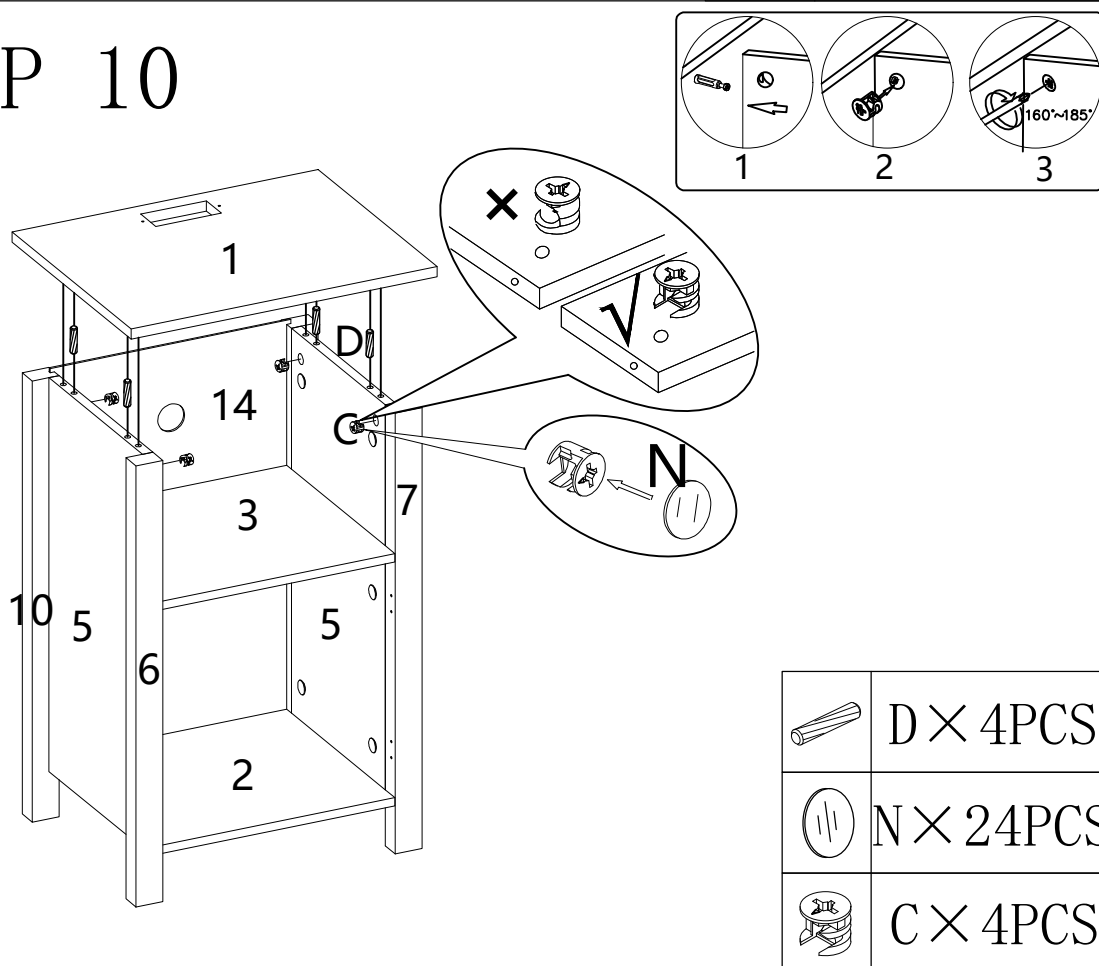

	A × 4PCS
---	----------

STEP 10



	D × 4PCS
	N × 24PCS
	C × 4PCS

Assembly

STEP 11

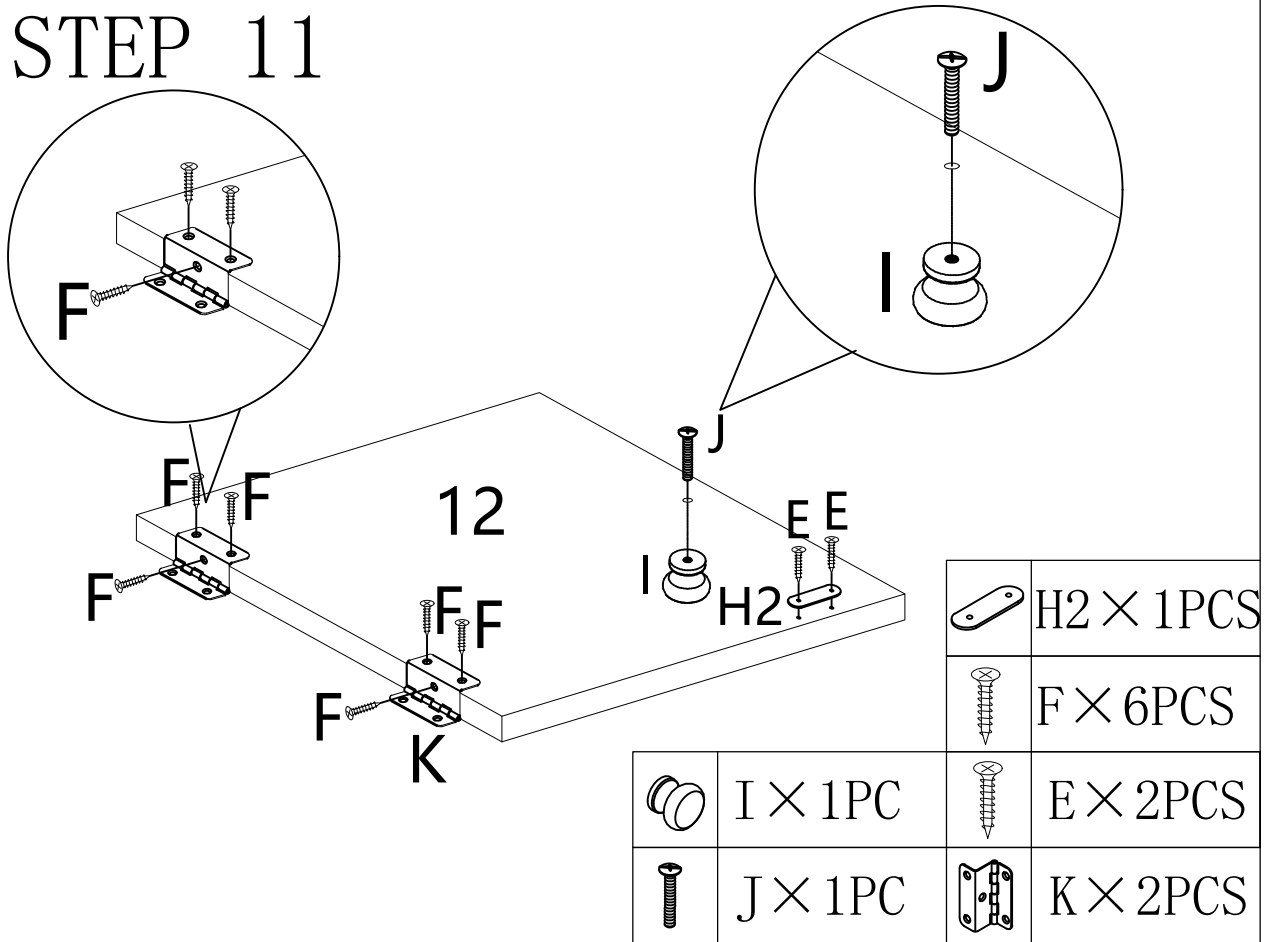

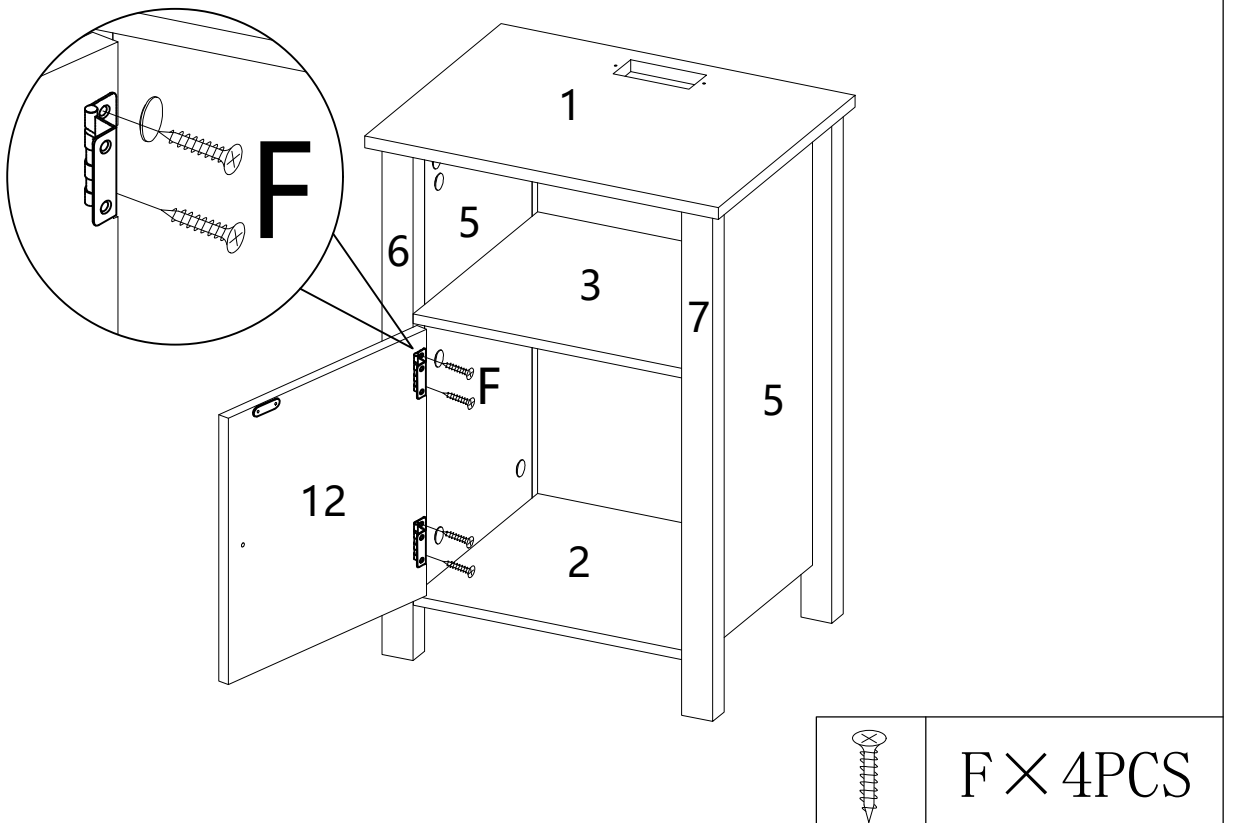

STEP 12

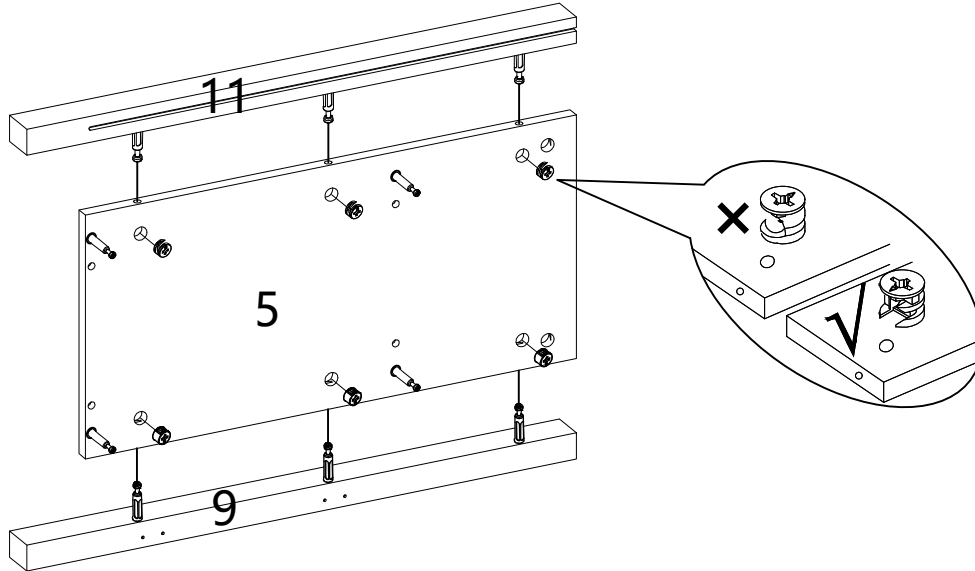
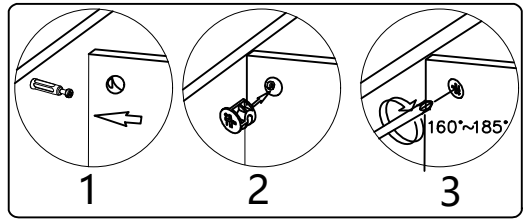

Assembly

STEP 13



 C × 6PCS

STEP 14

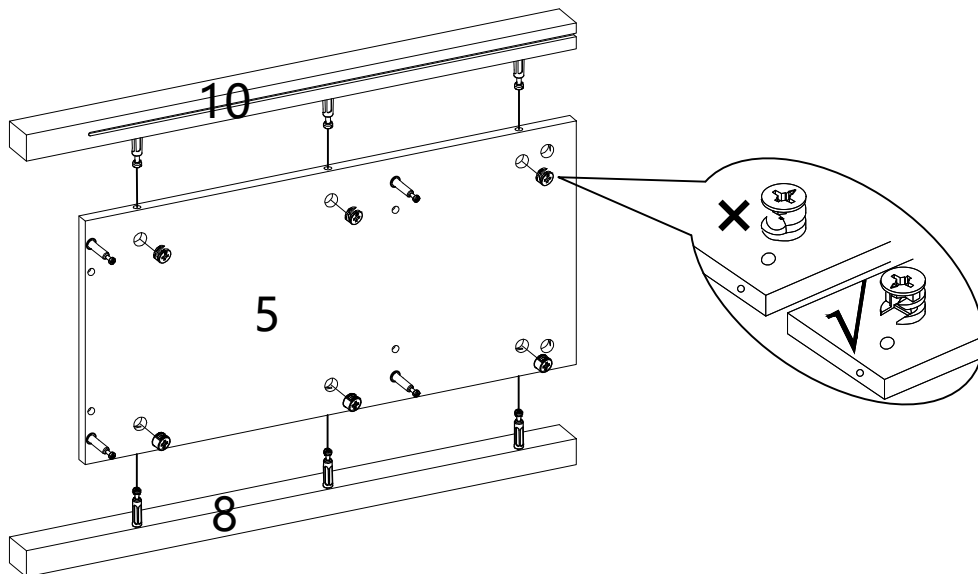
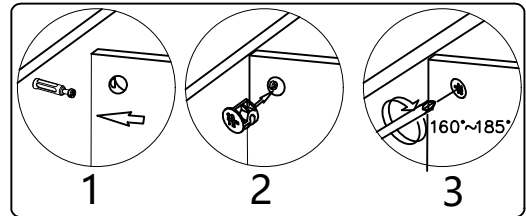

 C × 6PCS

Assembly

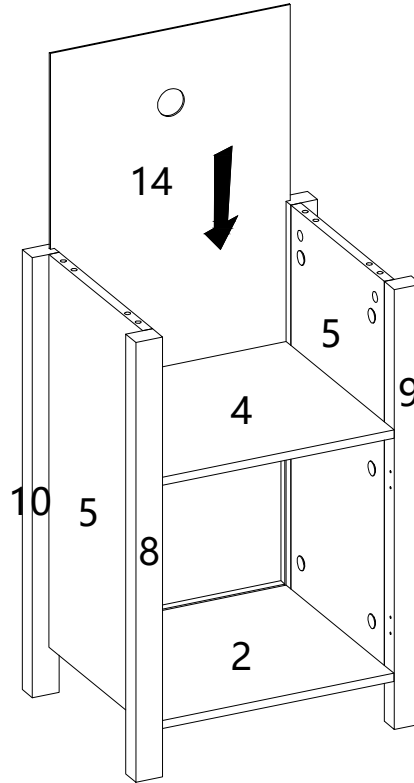

STEP 15

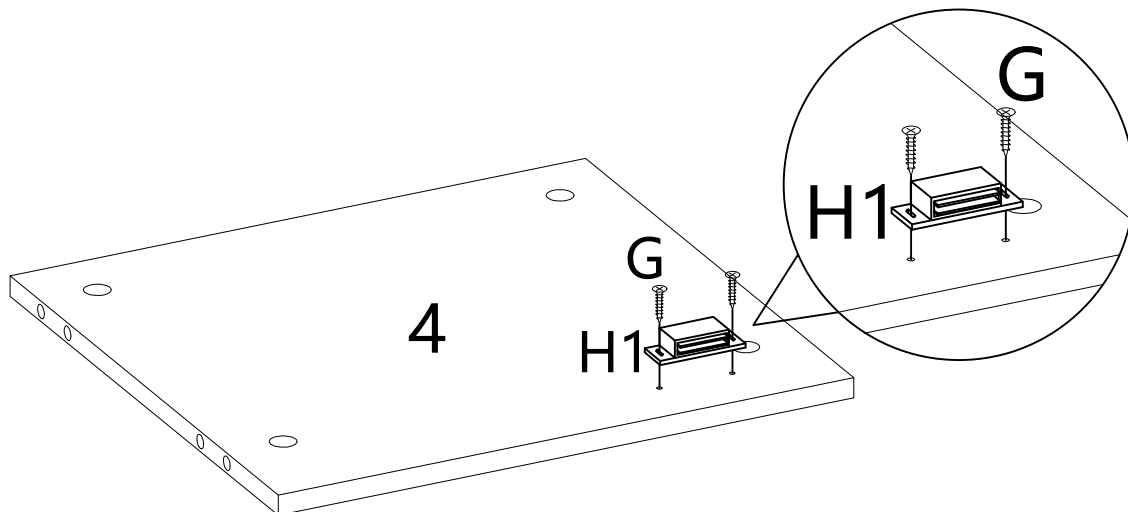

The thin backing plate must be located in the slot or it will block the opposite plate.

STEP 16



	H1 × 1PC
	G × 2PCS

Assembly

STEP 17

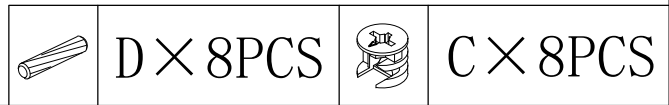
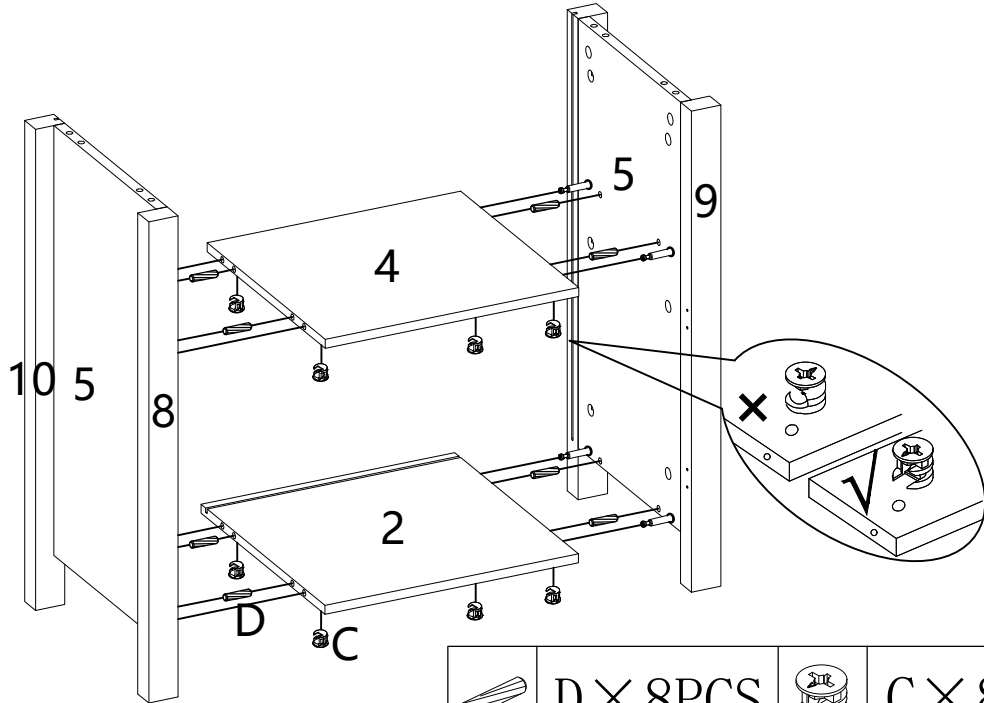
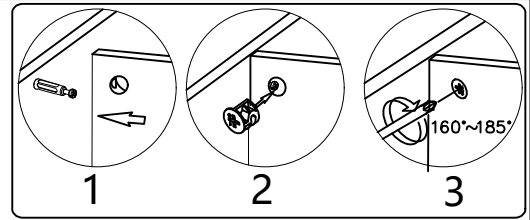

STEP 18

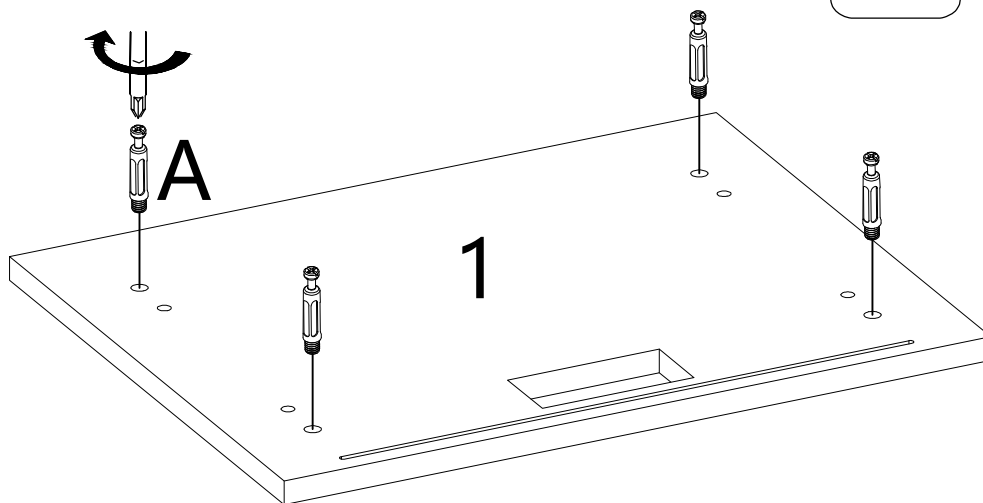
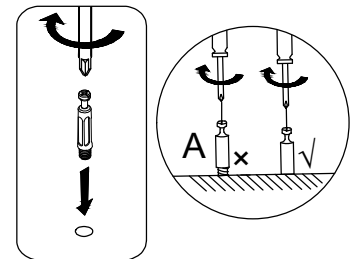

STEP 19

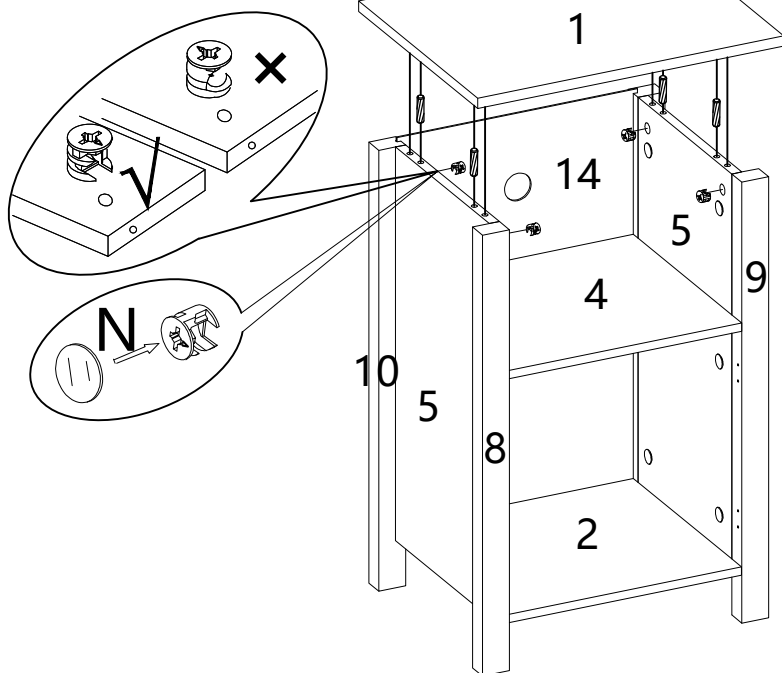
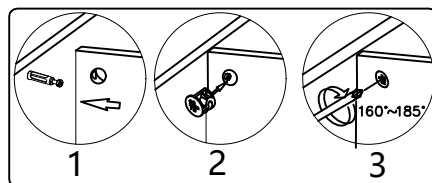

	D × 4PCS
	N × 24PCS
	C × 4PCS

STEP 20

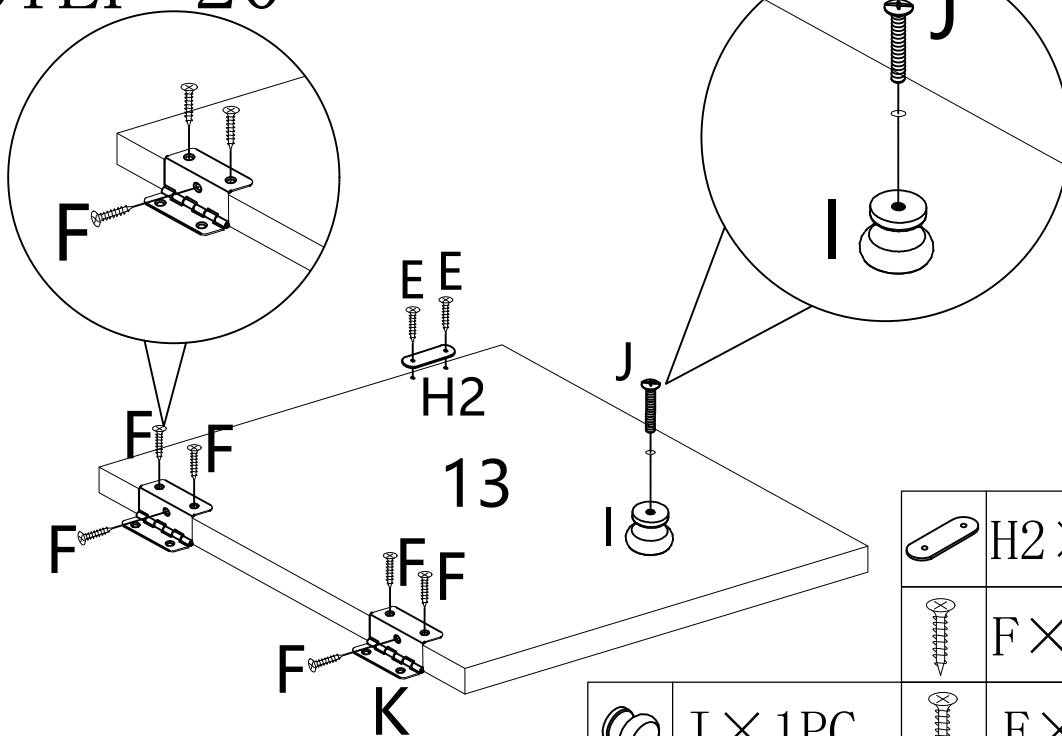

	H2 × 1PCS		F × 6PCS
	I × 1PC		E × 2PCS
	J × 1PC		K × 2PCS

Assembly

STEP 21

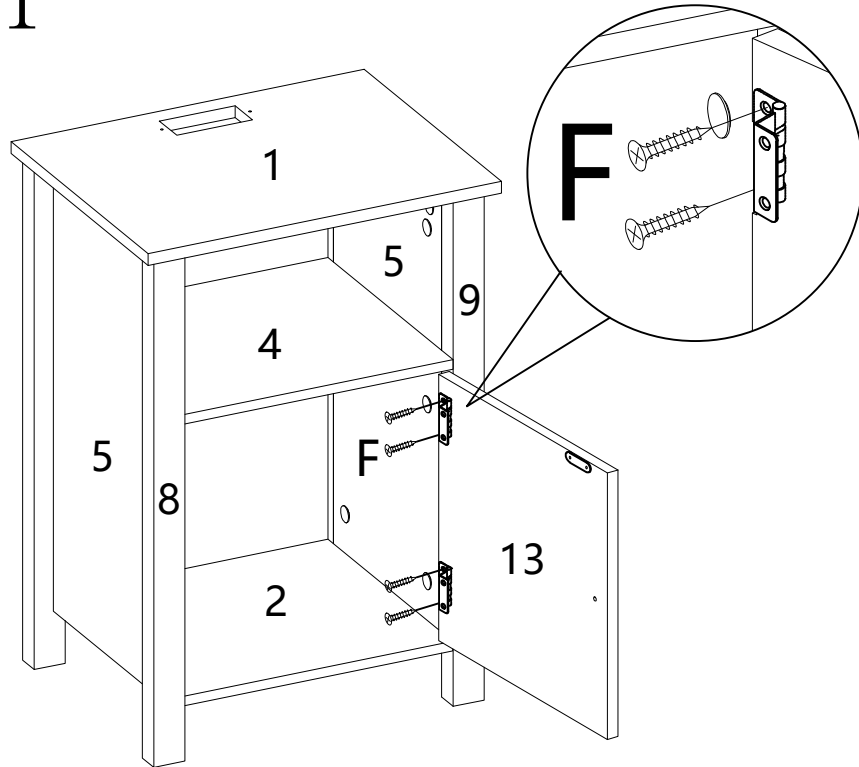

STEP 22

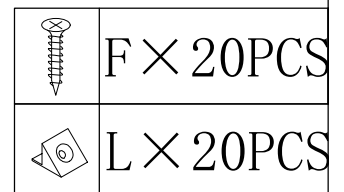
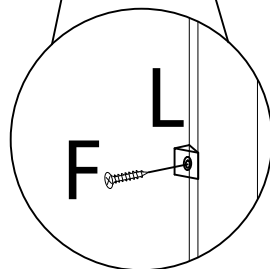
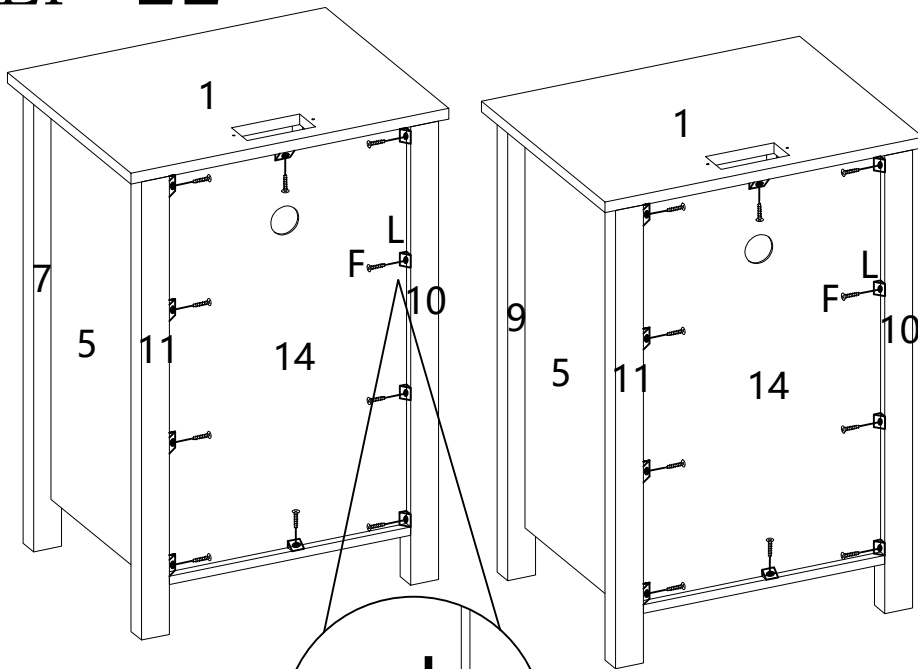

STEP 23

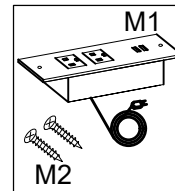
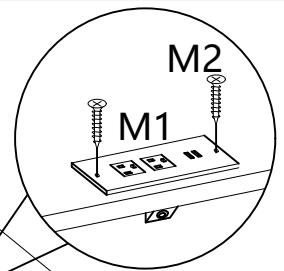
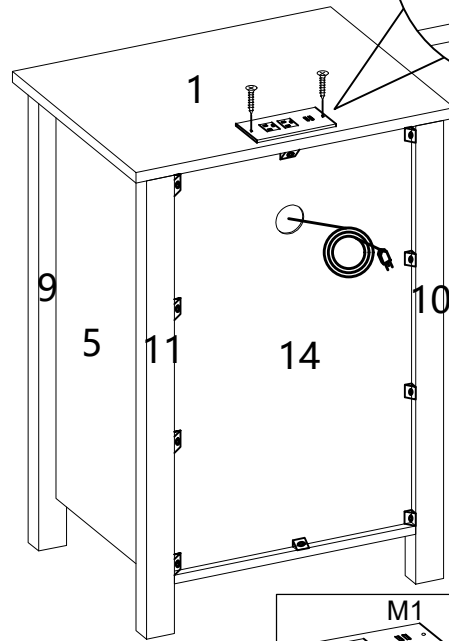
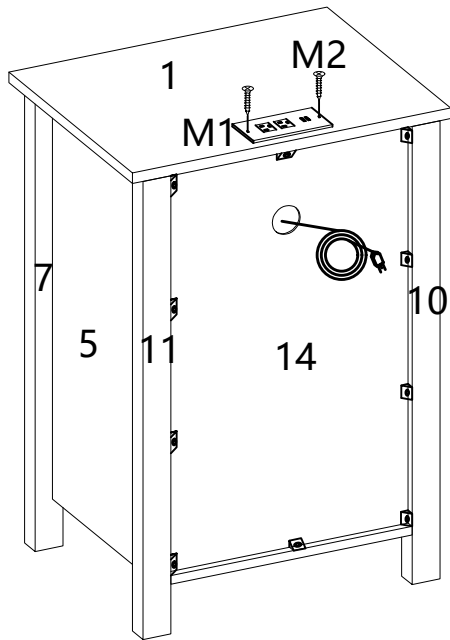

M × 2PCS

STEP 24

