

ASSEMBLY INSTRUCTIONS

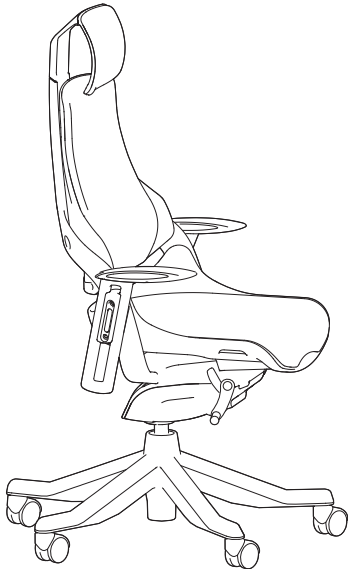

Thank you for purchasing our product!

Hardware

NOTE: The only hardware you will need are screws that come pre-installed on the armrests. Do not remove them from the armrests until advised during assembly.

Tools (Included)

Allen Wrench



MAIN PARTS LIST

Sitting unit

NOTE 1: This comes pre-assembled with the following pieces:

- A** Backrest
- B** Seat
- D** Mechanism
- H** Headrest

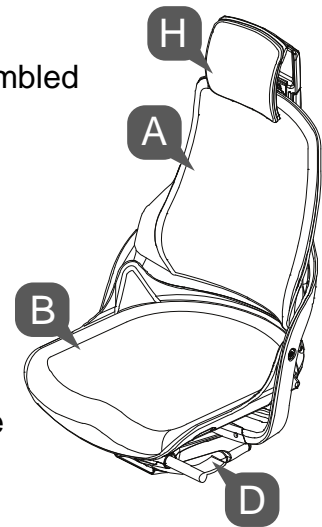

NOTE 2: Any component of the Sitting Unit can be removed and replaced individually.

C Nylon Star base



E Lift cylinder



F Casters

x5

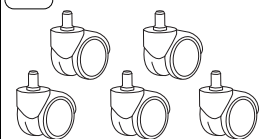

G-L Left armrest *

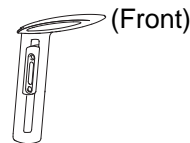

G-R Right armrest *

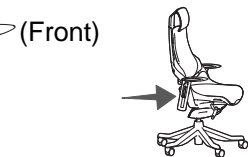
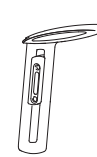

* Left and Right are defined by you sitting on the chair, not by looking at it.

For support with assembly questions & replacement parts please email us



Free shipping within **the 48 Contiguous United States.**



For international customers & **AK-HI-PR** orders, **the customer is responsible for shipping costs plus any International local taxes or duties.**

ASSEMBLY STEPS

STEP 1

FIRST:

F enters into C
by pressure

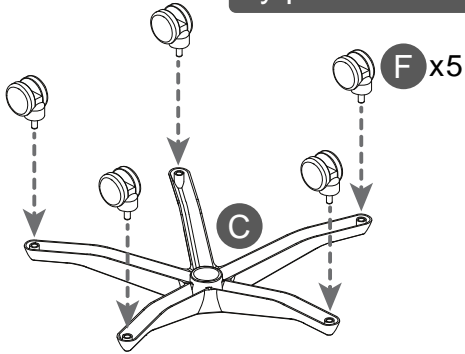

THEN:

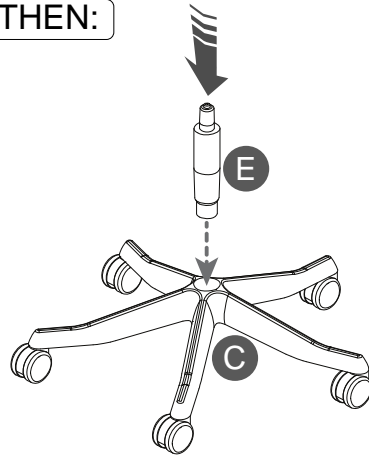

STEP 2

(View from underneath)

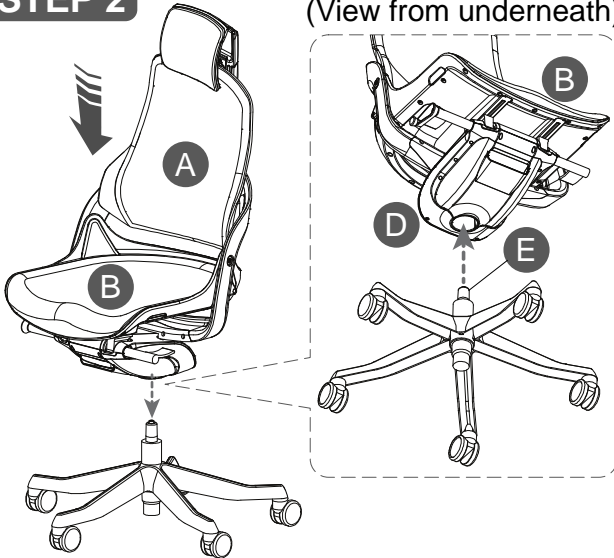

STEP 3

Discard this screw and the
plastic ring on both sides.

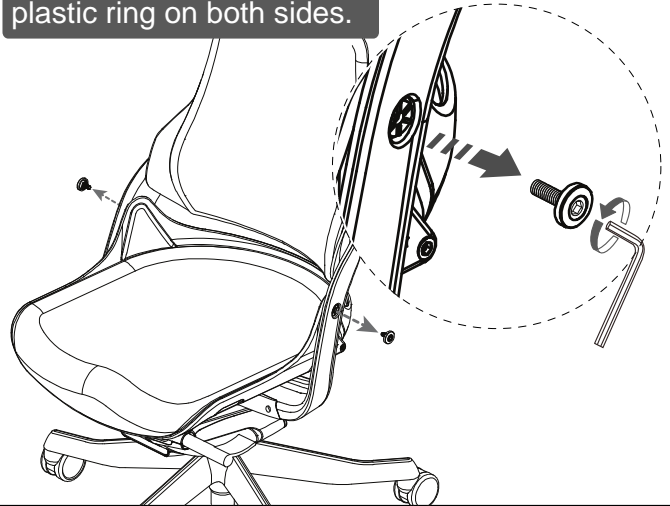

STEP 4

FIRST: Remove screws.

THEN: Reattach screws.

PAY ATTENTION!

- Top screw: Longer (45mm)
- Bottom screw: Shorter (30mm)

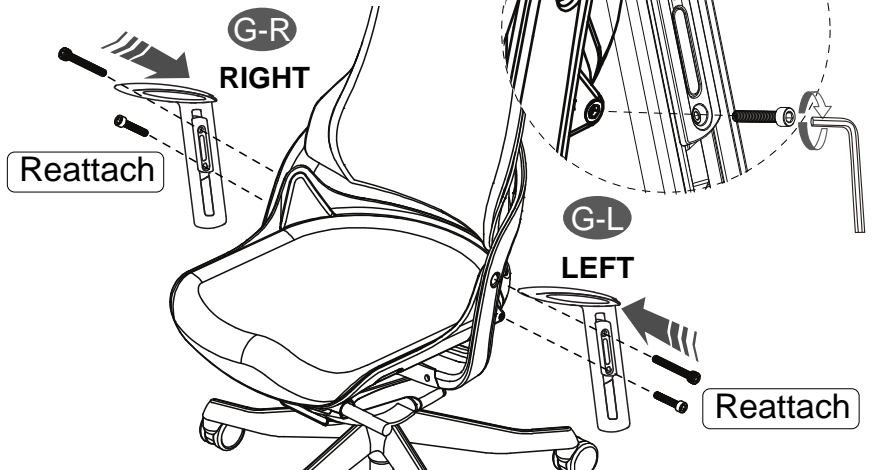
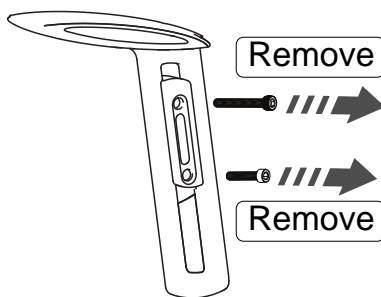

CHAIR'S FUNCTIONS

ADJUST CHAIR'S HEIGHT

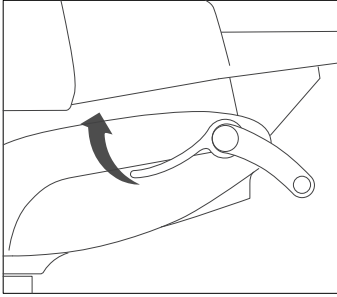

Pull handle UP.

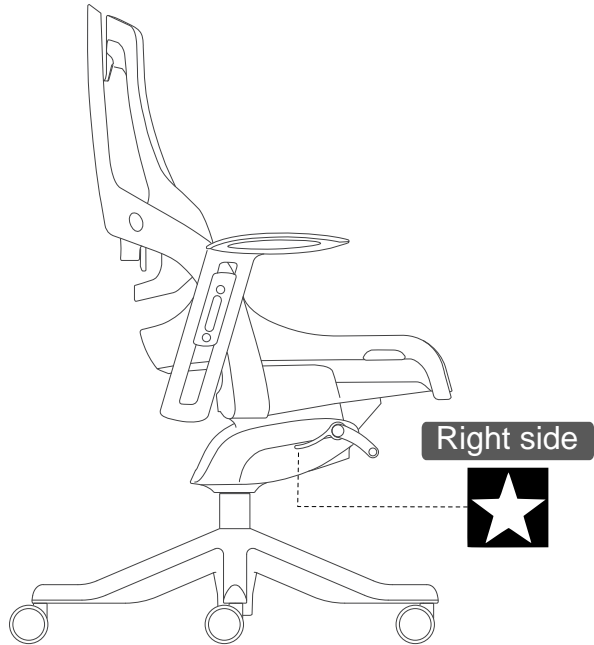
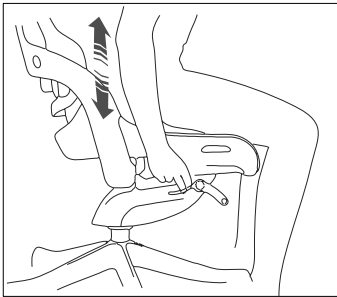

BACKREST RECLINING

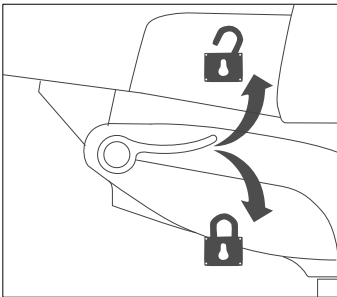

Unlocked: The backrest reclines freely.
Locked: The backrest is locked at an angle or in upright position.

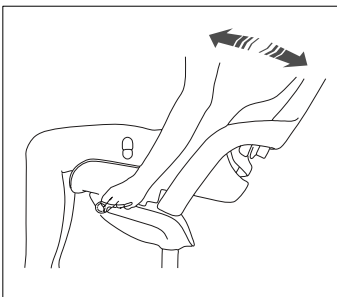

CHAIR'S FUNCTIONS

RECLINING TENSION

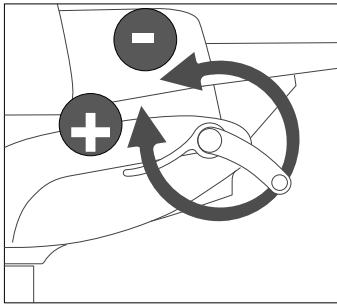

Turn (+): Apply more tension.
Turn (-): Apply less tension.
Less tension means easier reclining.

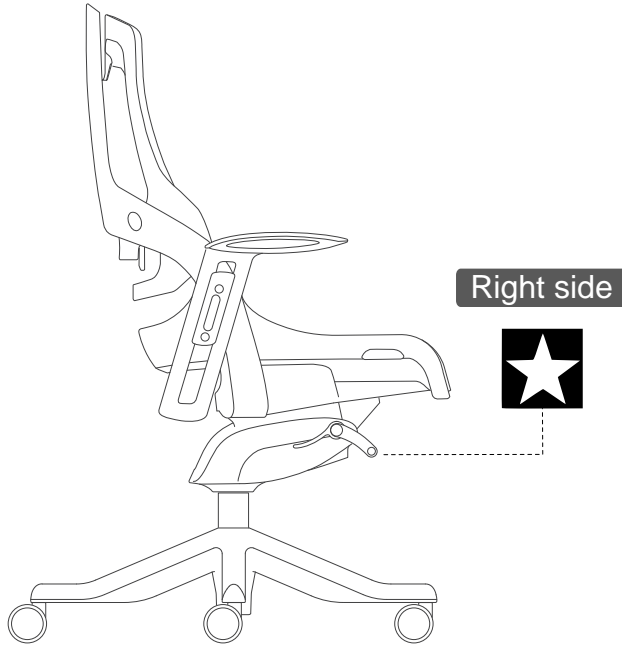

ADJUST BACKREST'S HEIGHT

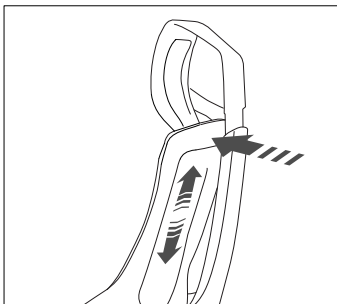

Push backrest forward and then
UP/DOWN.

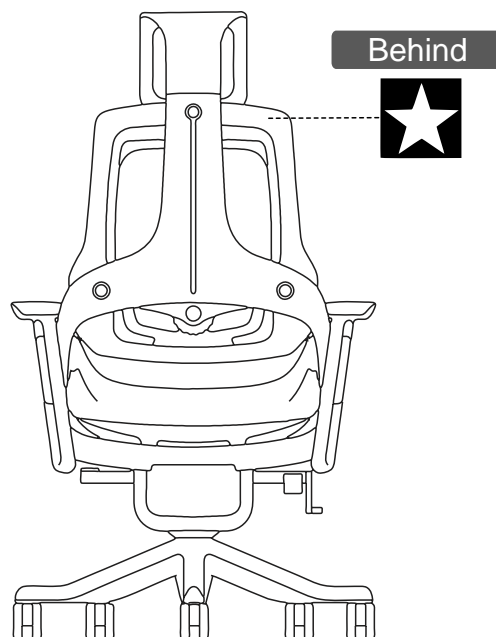

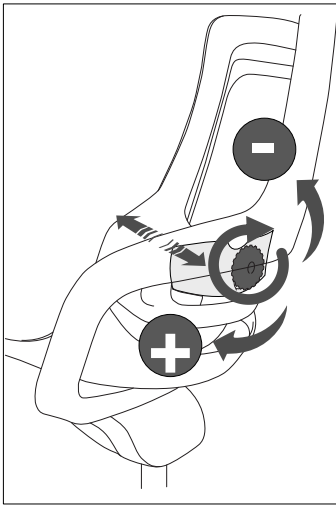
CHAIR'S FUNCTIONS**ADJUST LUMBAR SUPPORT**

Turn (+): Moves forward for more support.
Turn (-): Moves backward for less support.

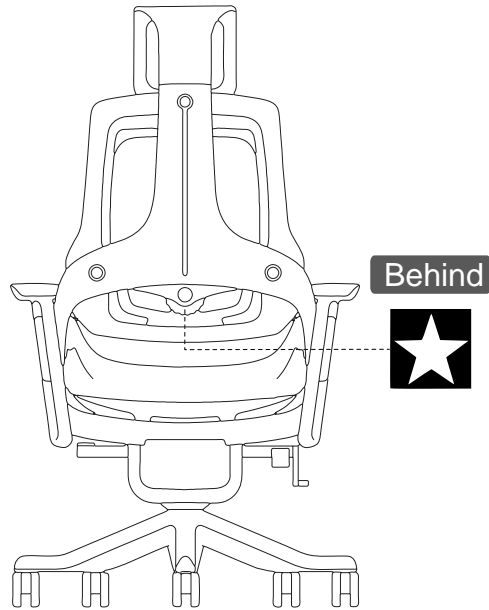
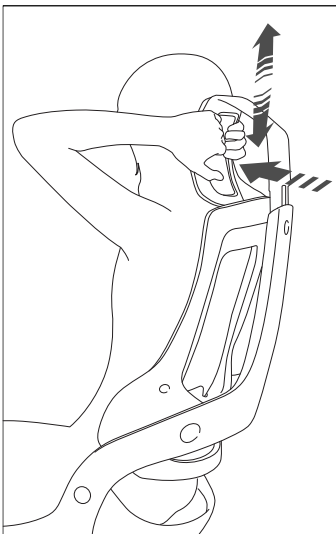
**ADJUST HEADREST'S HEIGHT**

Pull headrest forward and then
UP/DOWN.

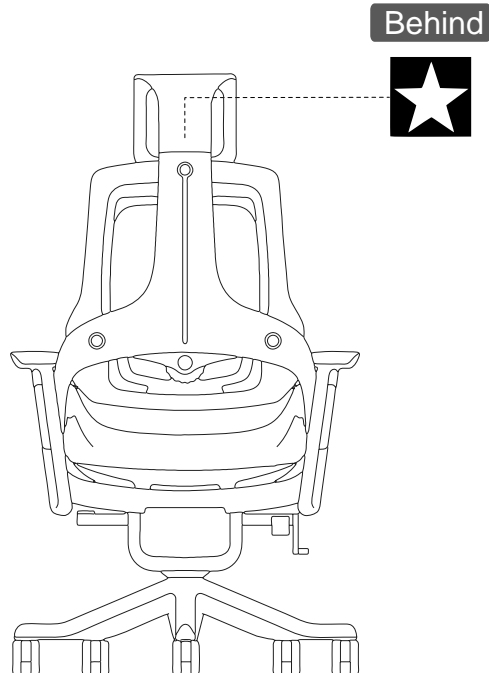

CHAIR'S FUNCTIONS

ADJUST ARMREST'S HEIGHT

Grab and move the armrest pad UP and then move the whole armrest UP/DOWN.

Right side

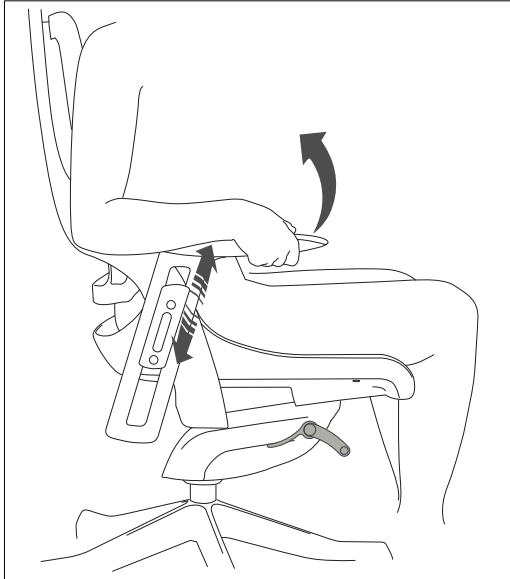

Left side

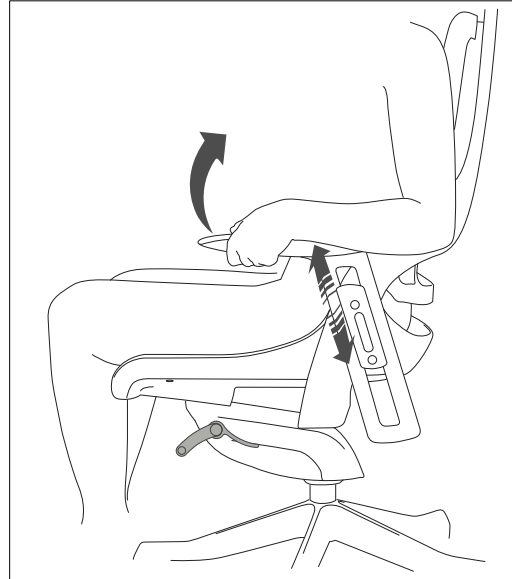

You can also swivel the arm pads INWARDS or OUTWARDS as you prefer.

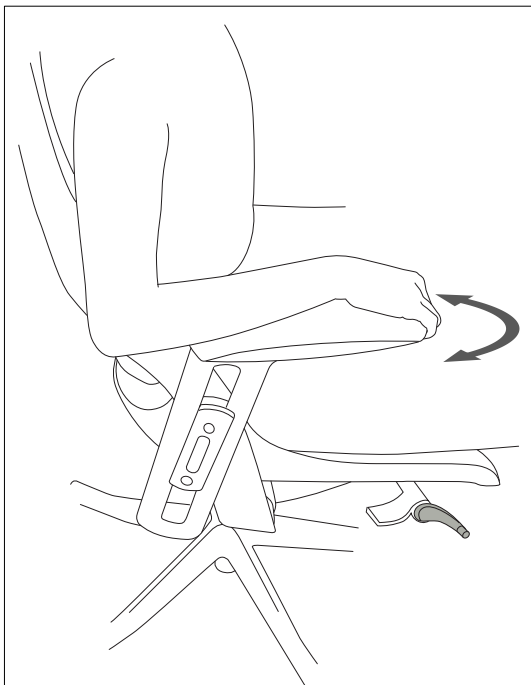

(View from above)

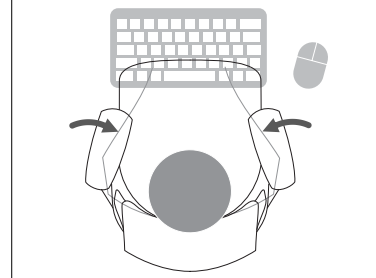

(View from above)

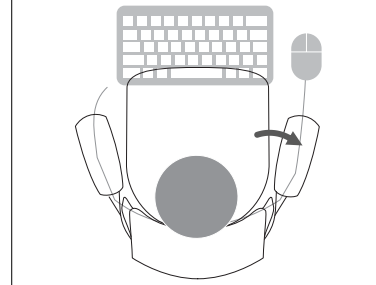

WARNINGS - Not paying attention to the following warnings could result in injuries.

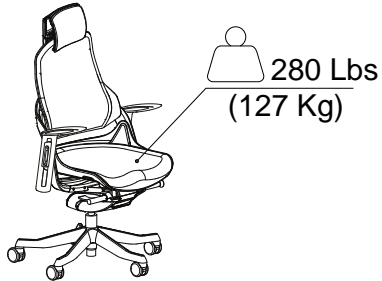

Only one person at a time and refrain from sitting on the edge of the seat to prevent the chair from tipping over.



Do not stand on the chair.

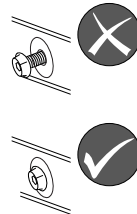

Do not use the chair if the frame parts are damaged, or if any of the screws are loose or missing.

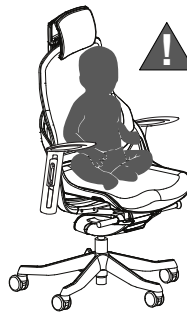

Do not leave babies or toddlers unattended while seated on the chair, always ensure adult supervision. Keep children from playing with the chair for their safety.

CARE AND MAINTENANCE

Clean with a soft cloth lightly dampened in a solution of smooth soap and water.

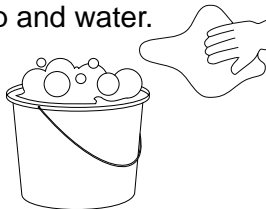

Do not use solvents or abrasive materials.



Do not expose to direct sunlight or to extreme environmental conditions.

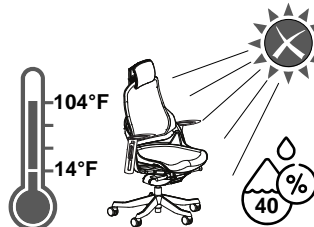

Inspect the chair thoroughly every 4 months and re-tighten the screws.

