

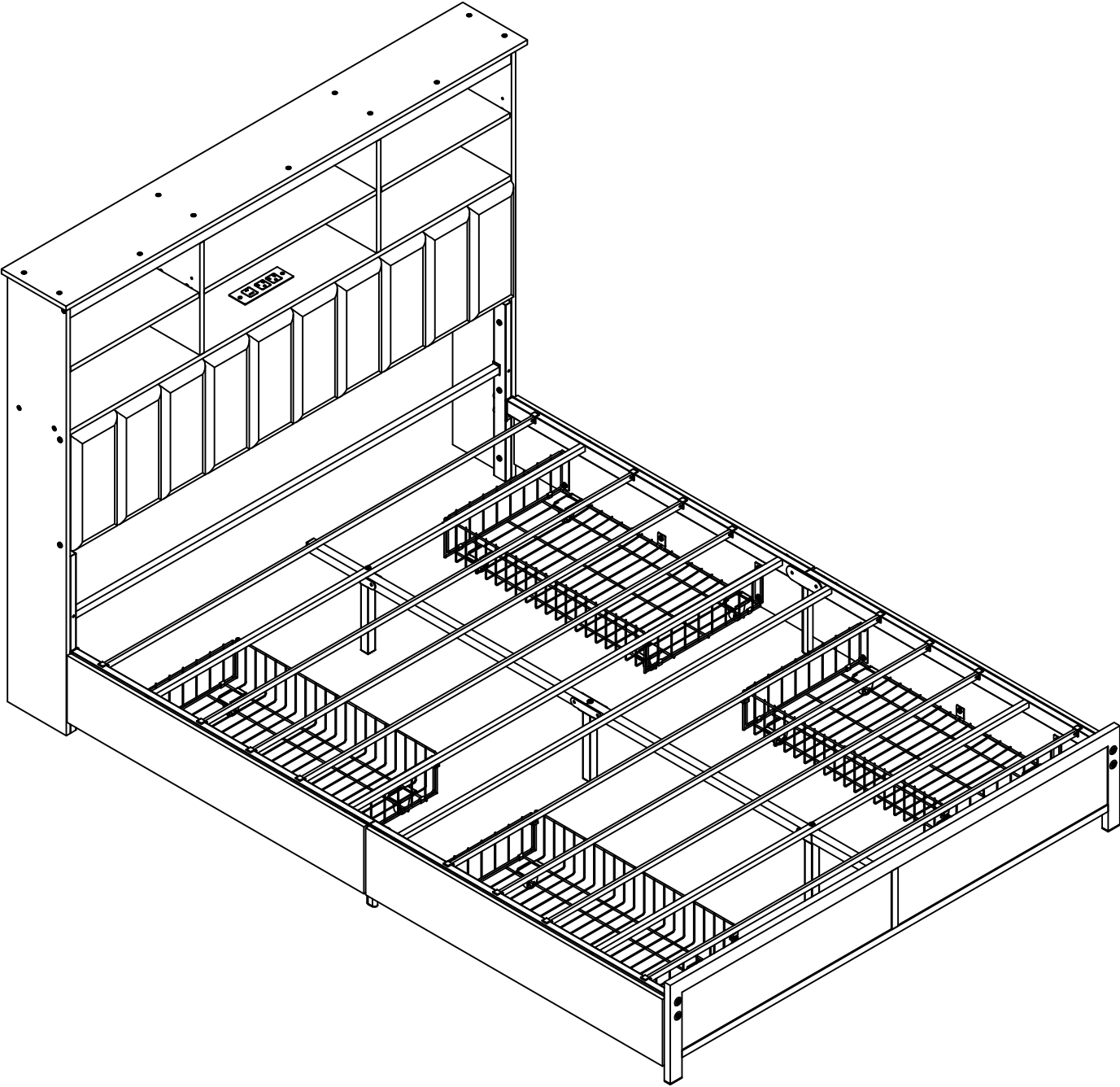

Assembly instruction
Bed Frame With LED & Power Outlet
V-BF23-0426B-Q/F

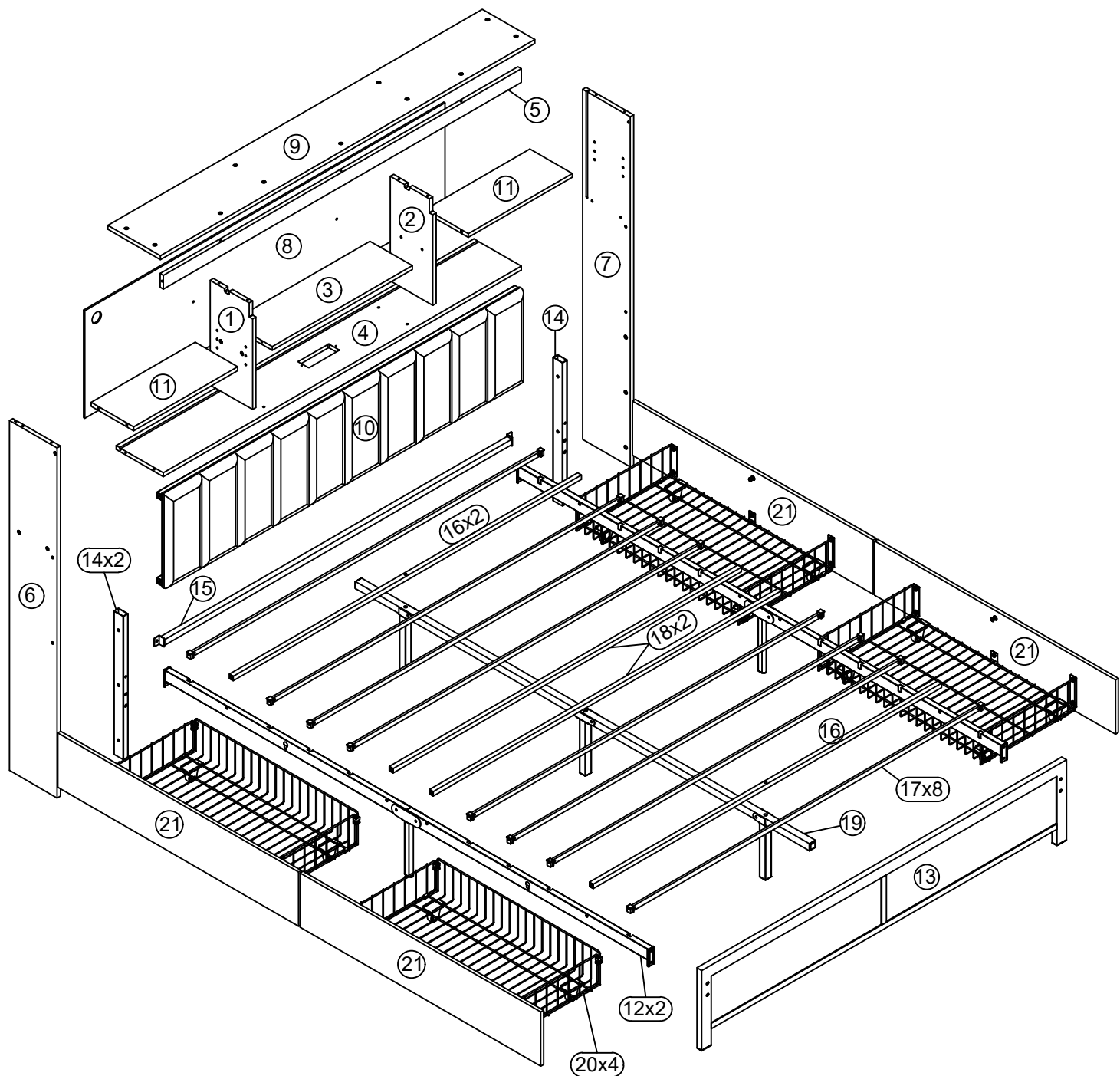







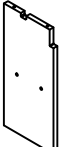
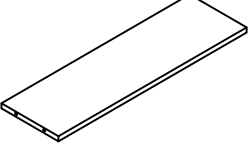
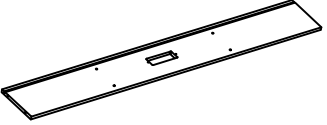
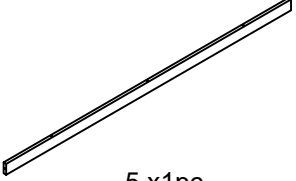
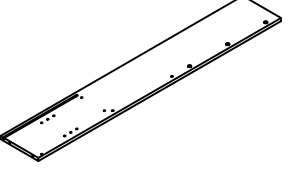
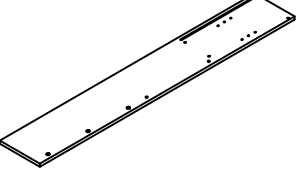
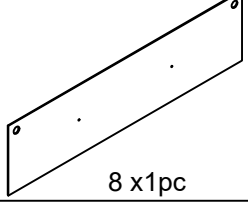
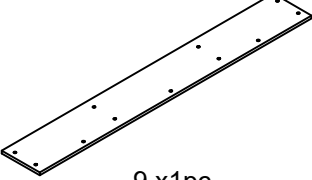
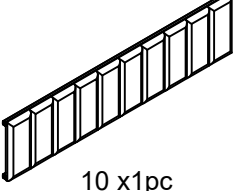
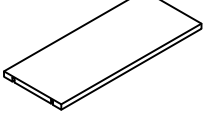
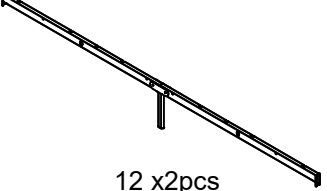
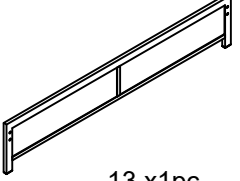
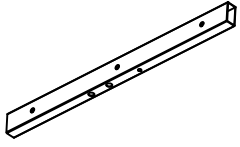
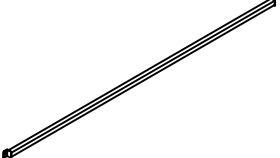
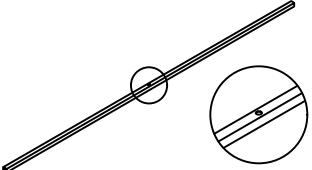
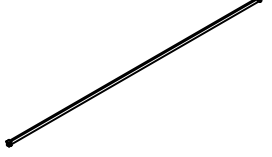
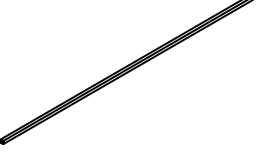
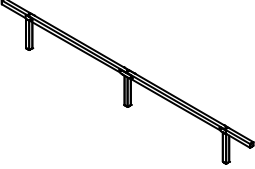
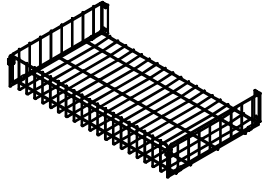
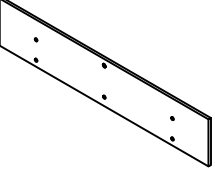

Installation Manual

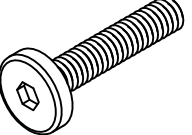
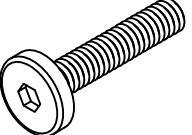
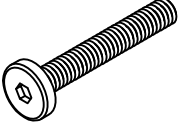
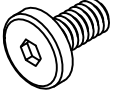
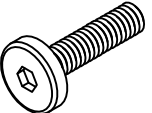

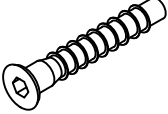
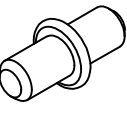
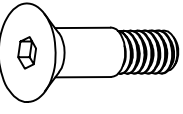
PART LIST

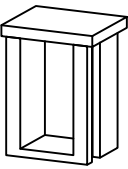
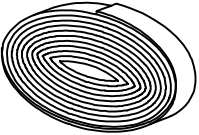
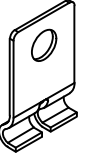
 1 x1pc	 2 x1pc	 3 x1pc	 4 x1pc
 5 x1pc	 6 x1pc	 7 x1pc	 8 x1pc
 9 x1pc	 10 x1pc	 11 x2pcs	 12 x2pcs
 13 x1pc	 14 x2pcs	 15 x1pc	 16 x2pcs
 17 x8pcs	 18 x2pcs	 19 x1pc	 20 x4pcs
			 21 x4pcs

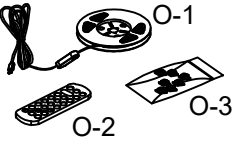
HARDWARE LIST

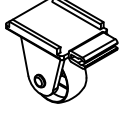
 M8x55mm Ⓐ x4pcs+1pc	 M8x40mm Ⓑ x4pcs+1pc	 M6x50mm Ⓒ x15pcs+1pc	 M6x10mm Ⓓ x22pcs+2pcs	 M6x30mm Ⓔ x6pcs+1pc
 Ø3.5x12mm Ⓕ x5pcs+1pc	 Ø6.1x45mm Ⓖ x27pcs+2pcs	 M6x10mm Ⓗ x8pcs+1pc	 M8x24mm Ⓖ x4pcs+1pc	 4mm Ⓙ x1pc
 Ⓚ x2pcs	 Ⓛ x1pc	 Ⓜ x4pcs+2pcs	 Ⓝ x1pc	 Ⓞ x1pc
 Ⓟ x8pcs+2pcs	 Ⓠ x16pcs			

1

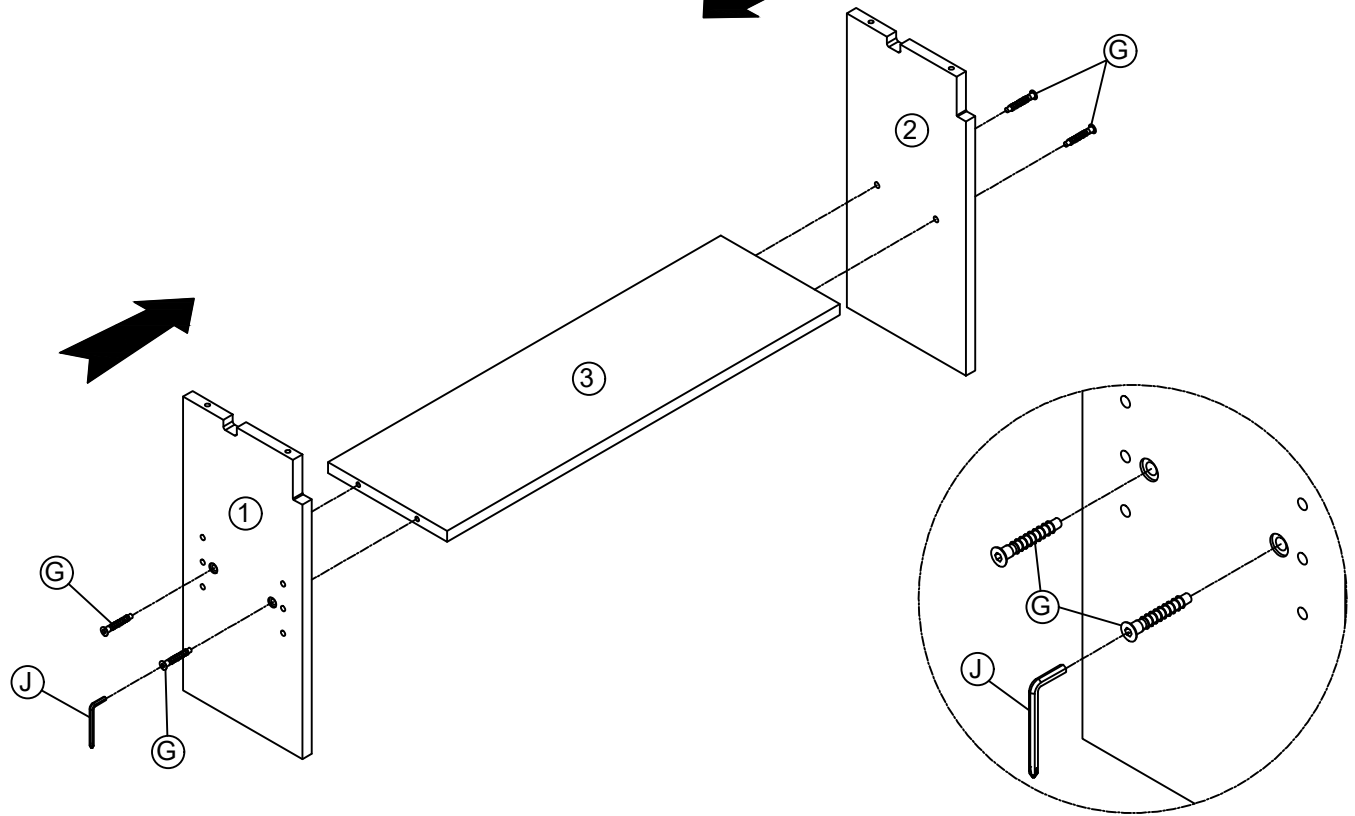

Ø6.1x45mm
G x4pcs

4mm
J x1pc

2

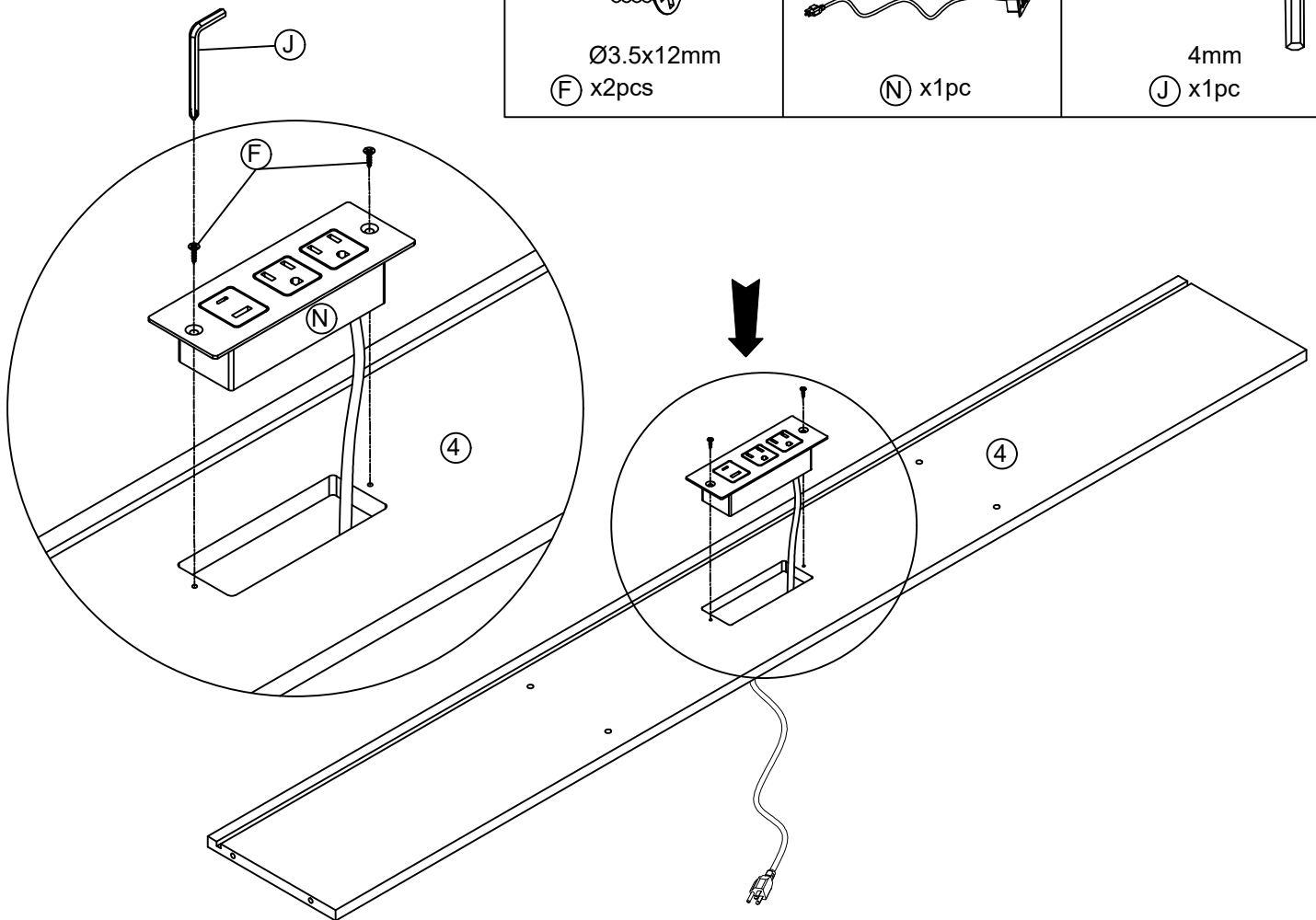

Ø3.5x12mm
F x2pcs

N x1pc

4mm
J x1pc

3

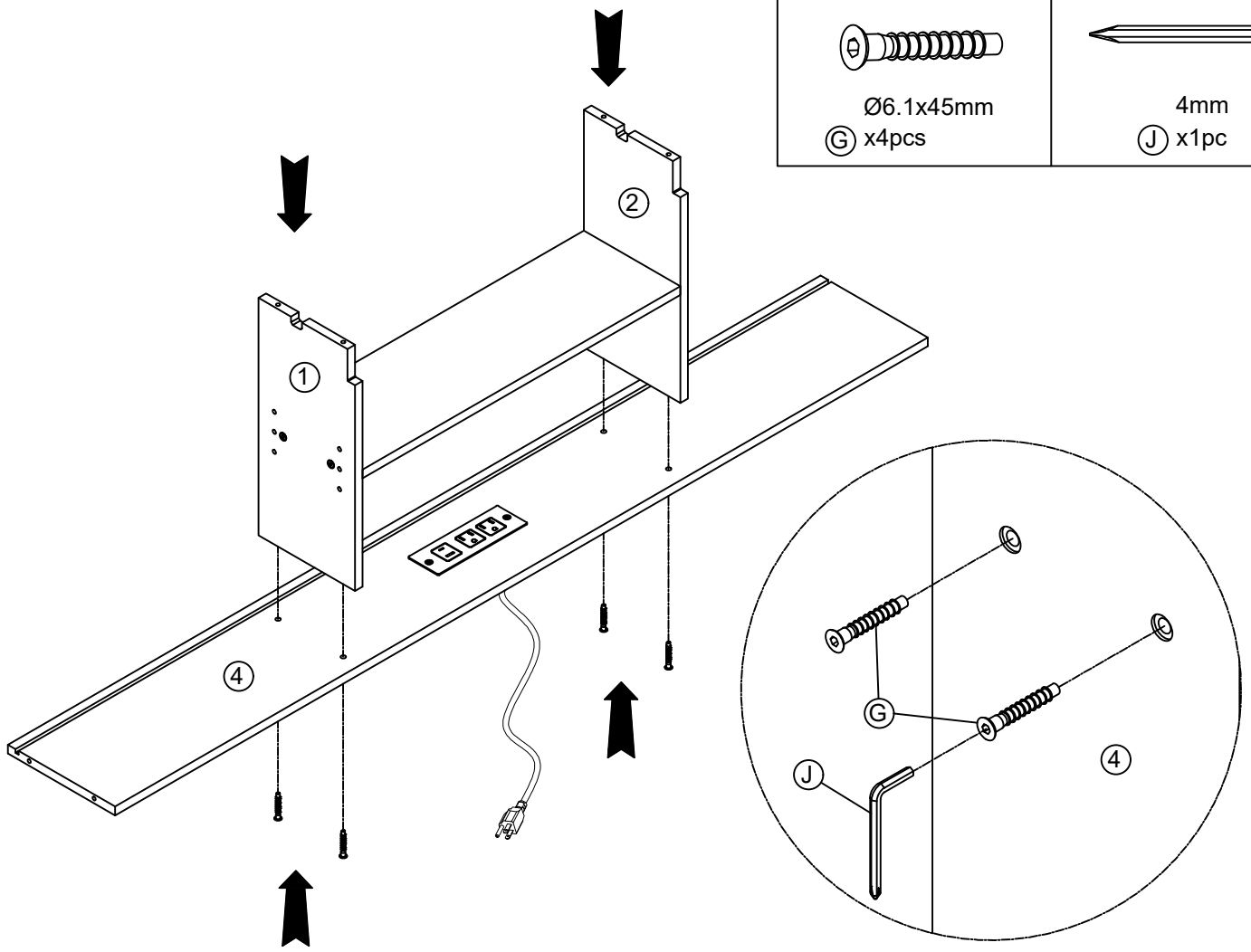

4

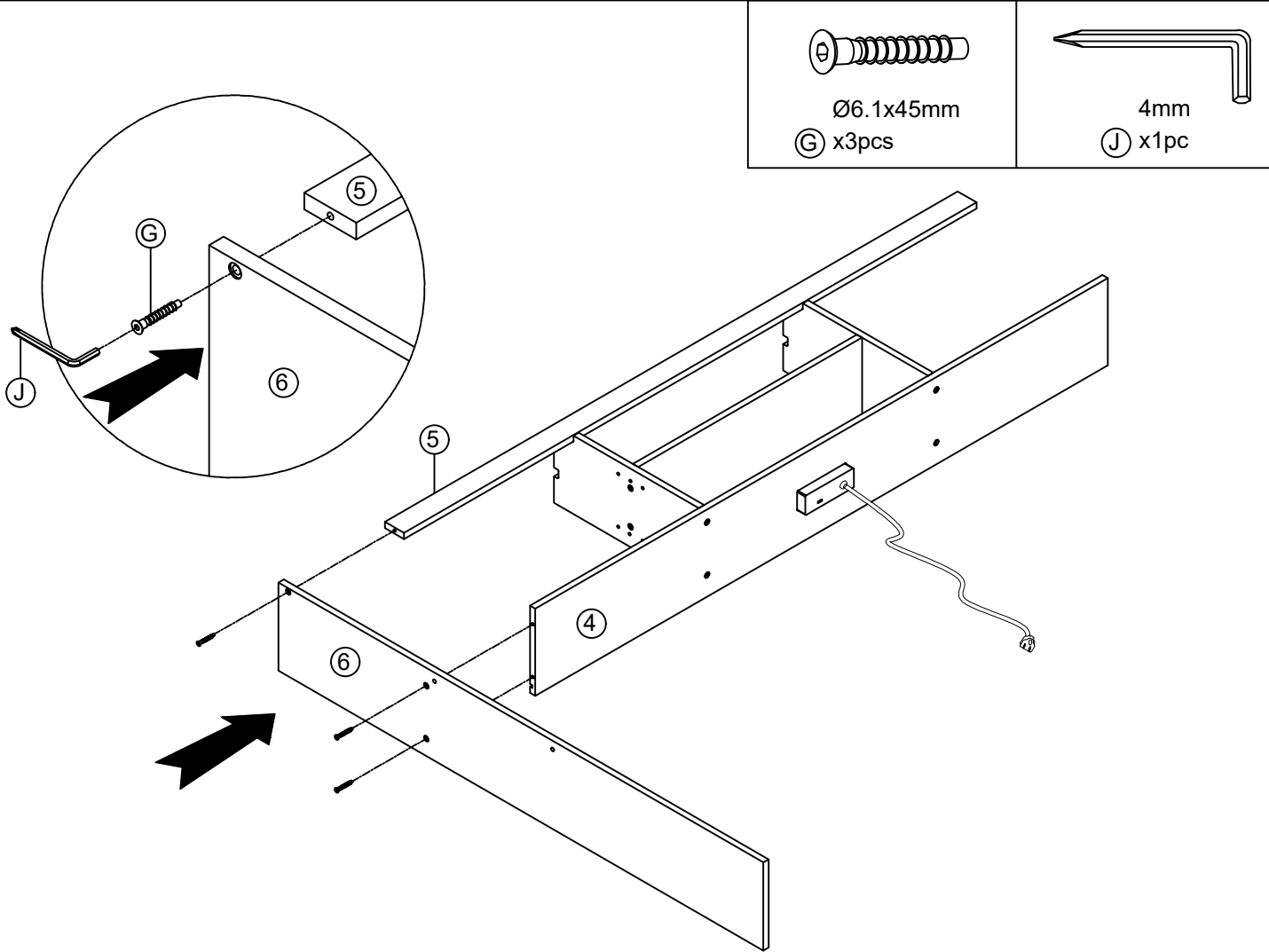

5

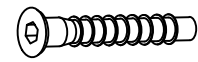

Ø6.1x45mm
G x3pcs

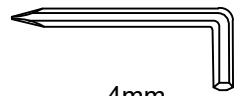

4mm
J x1pc

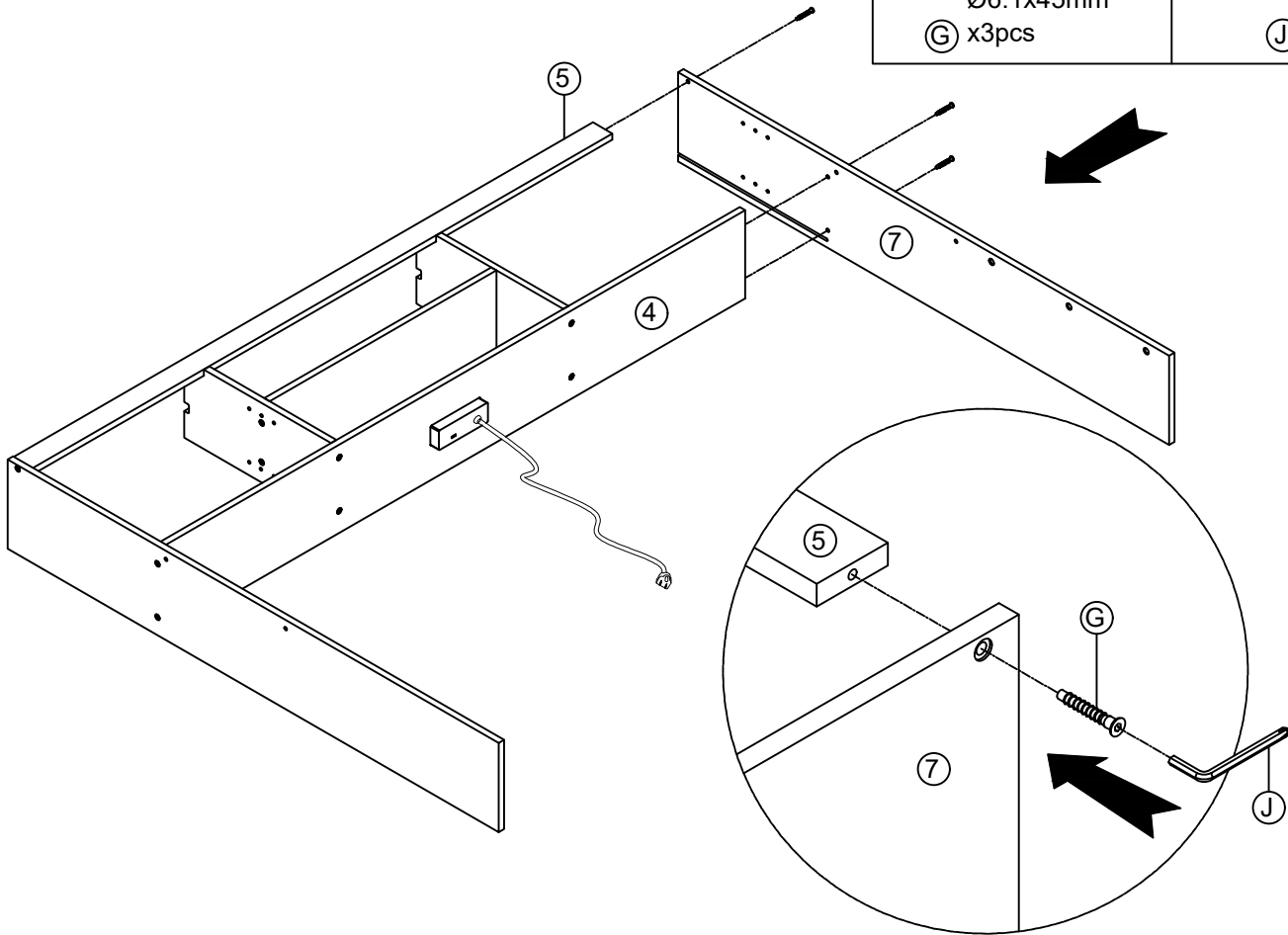

6

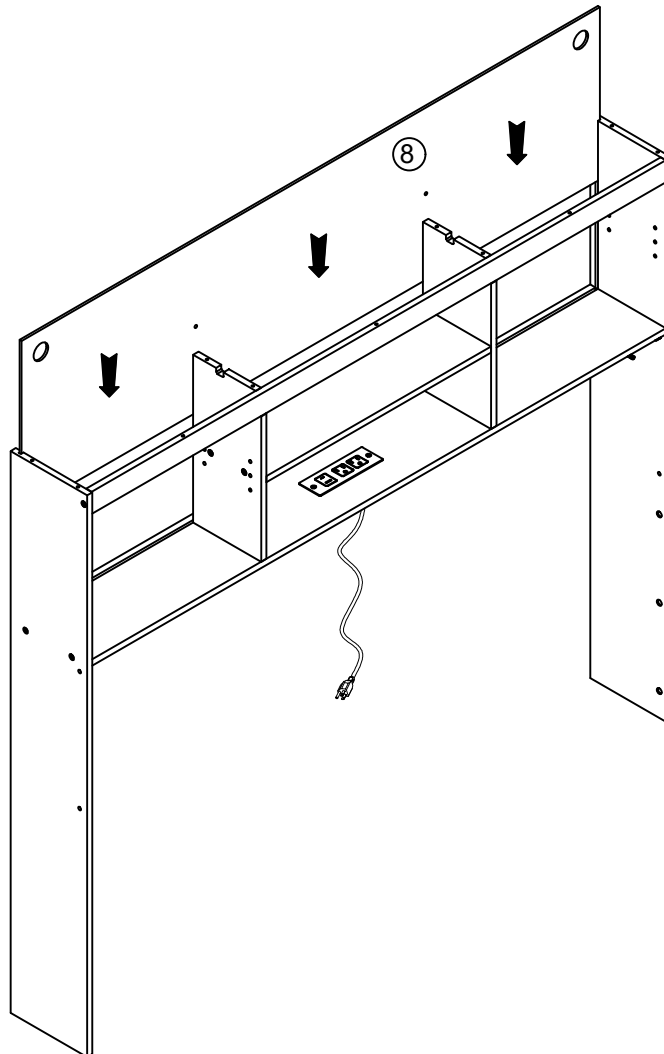

7

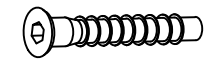
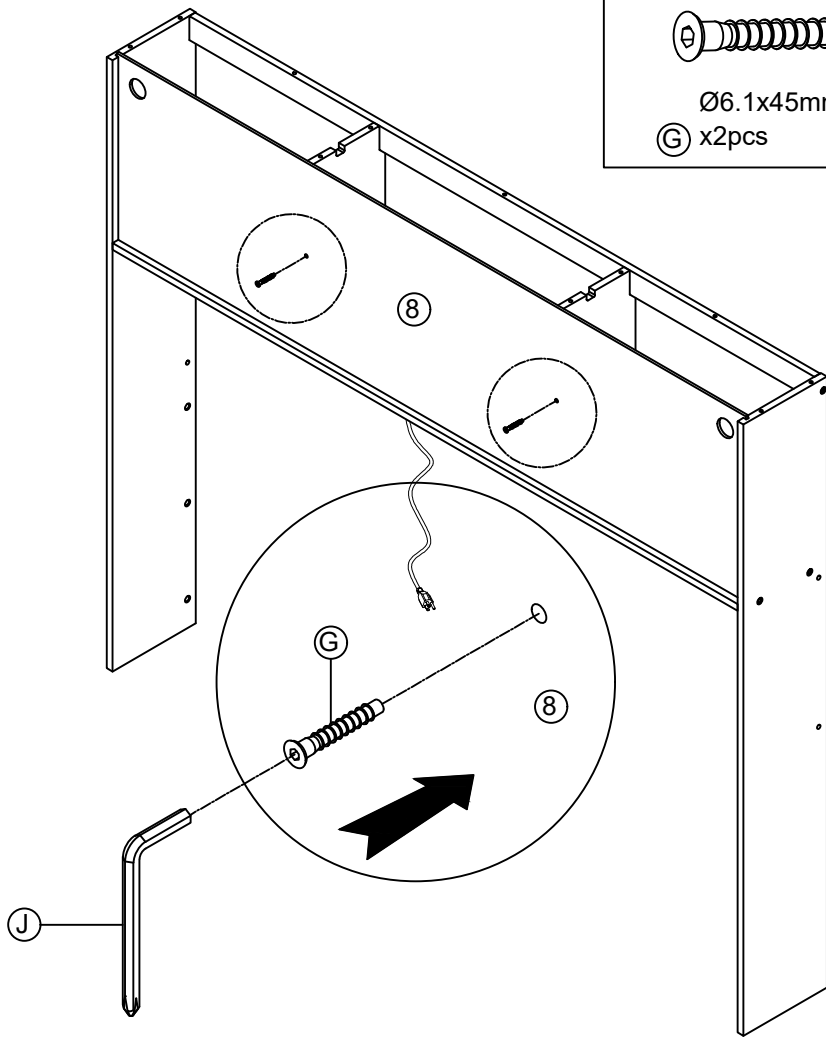

Ø6.1x45mm
G x2pcs

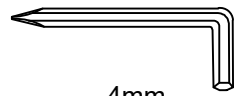

4mm
J x1pc

8

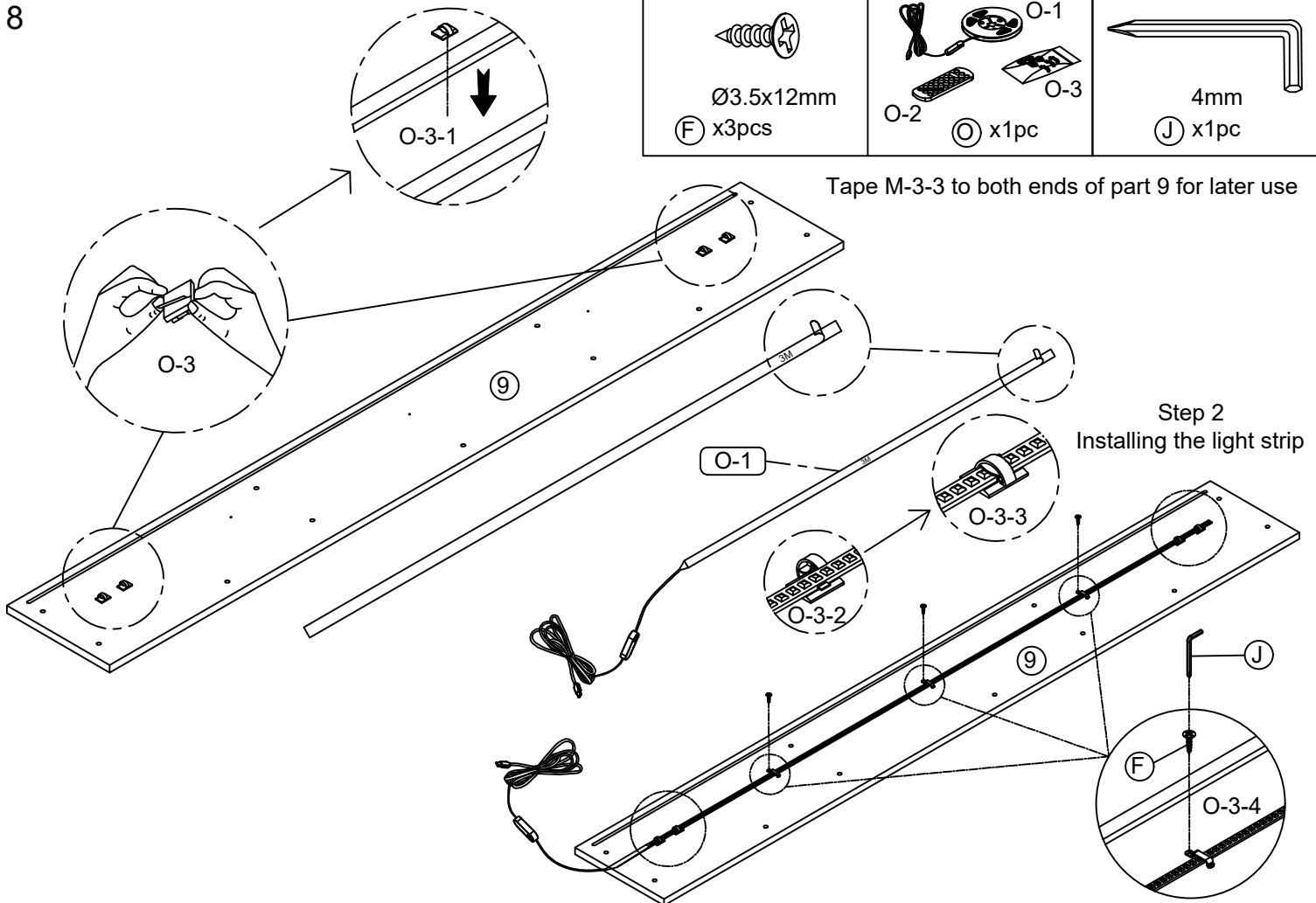

Ø3.5x12mm
F x3pcs

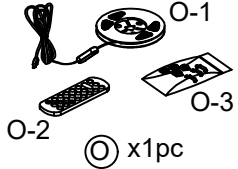

O-1
O-2
O-3
O x1pc

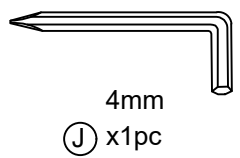



4mm
J x1pc

Tape M-3-3 to both ends of part 9 for later use

Step 2
Installing the light strip

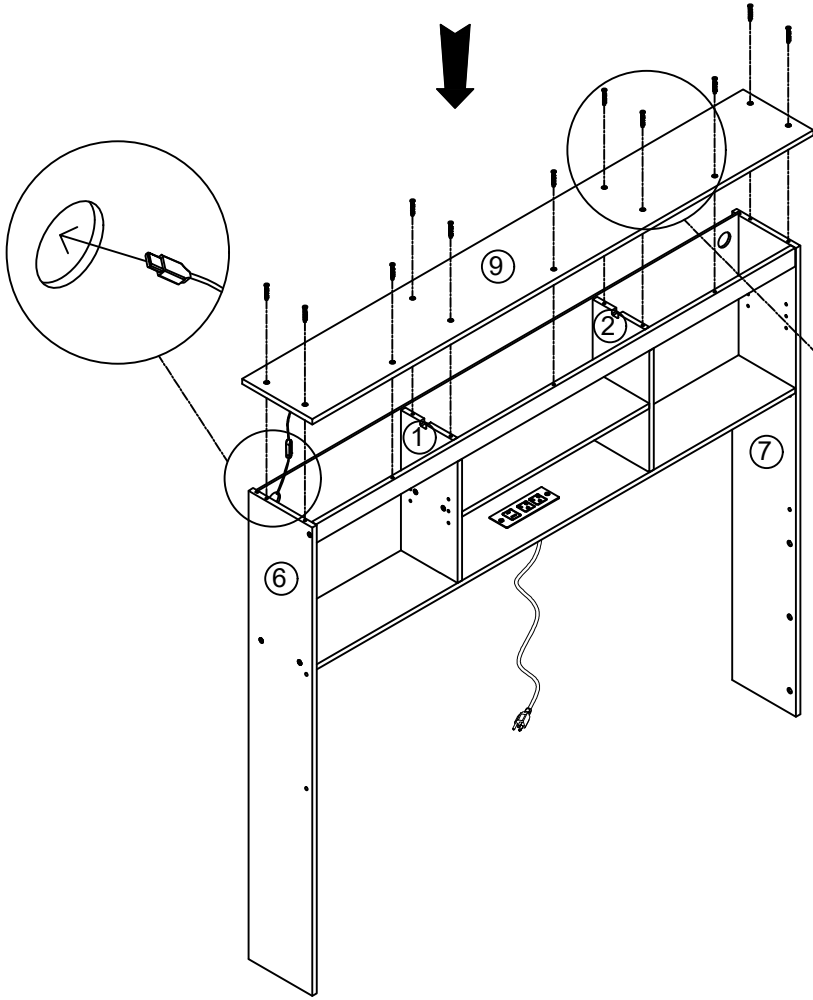
9

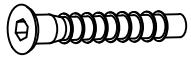

	
<p>Ø6.1x45mm G x11pcs</p>	<p>4mm J x1pc</p>

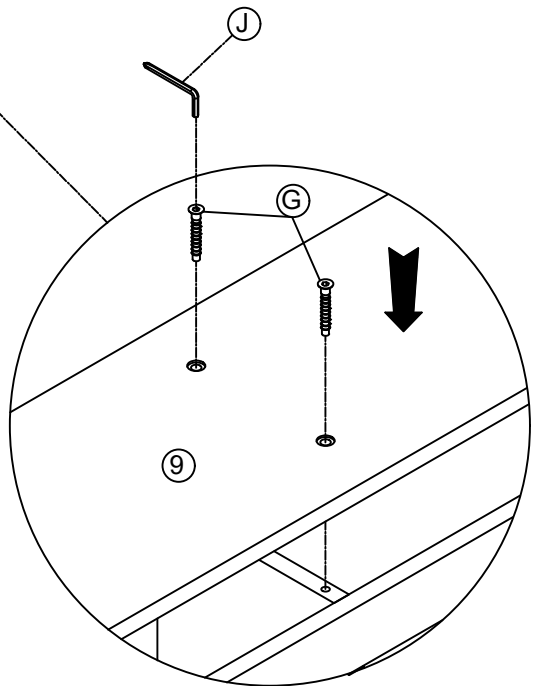

10

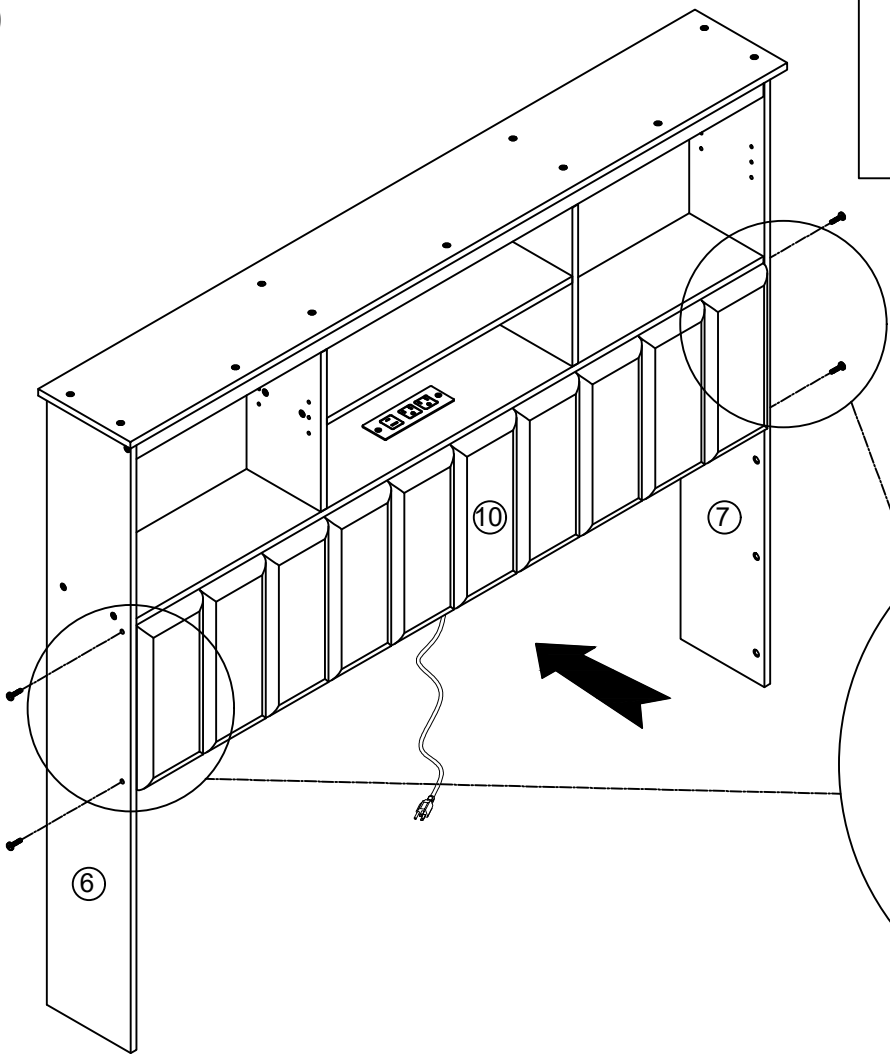

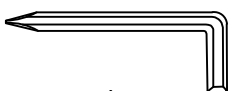
	
<p>M6x50mm C x4pcs</p>	<p>4mm J x1pc</p>

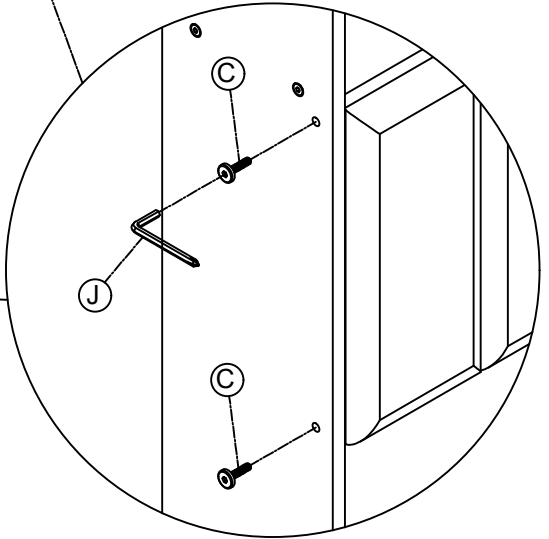

11

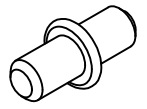
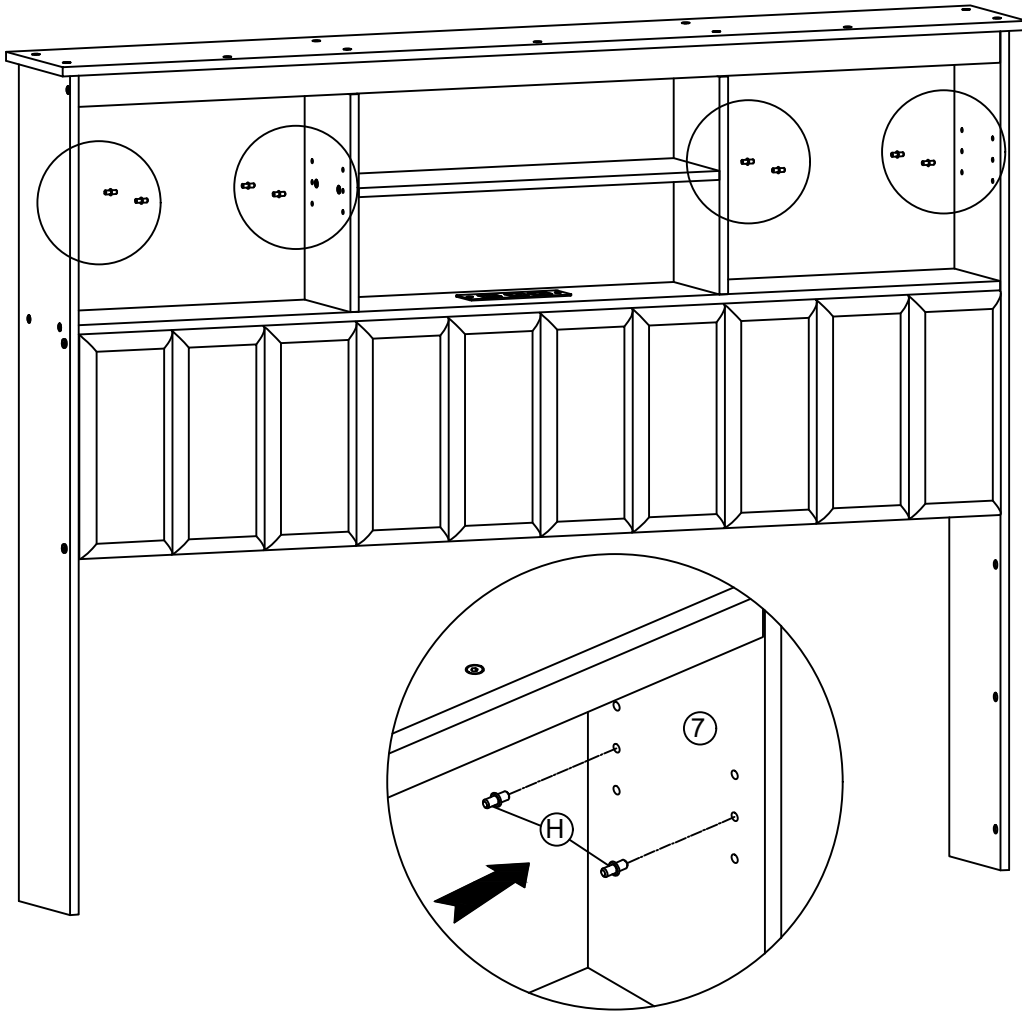

(H) x8pcs

12

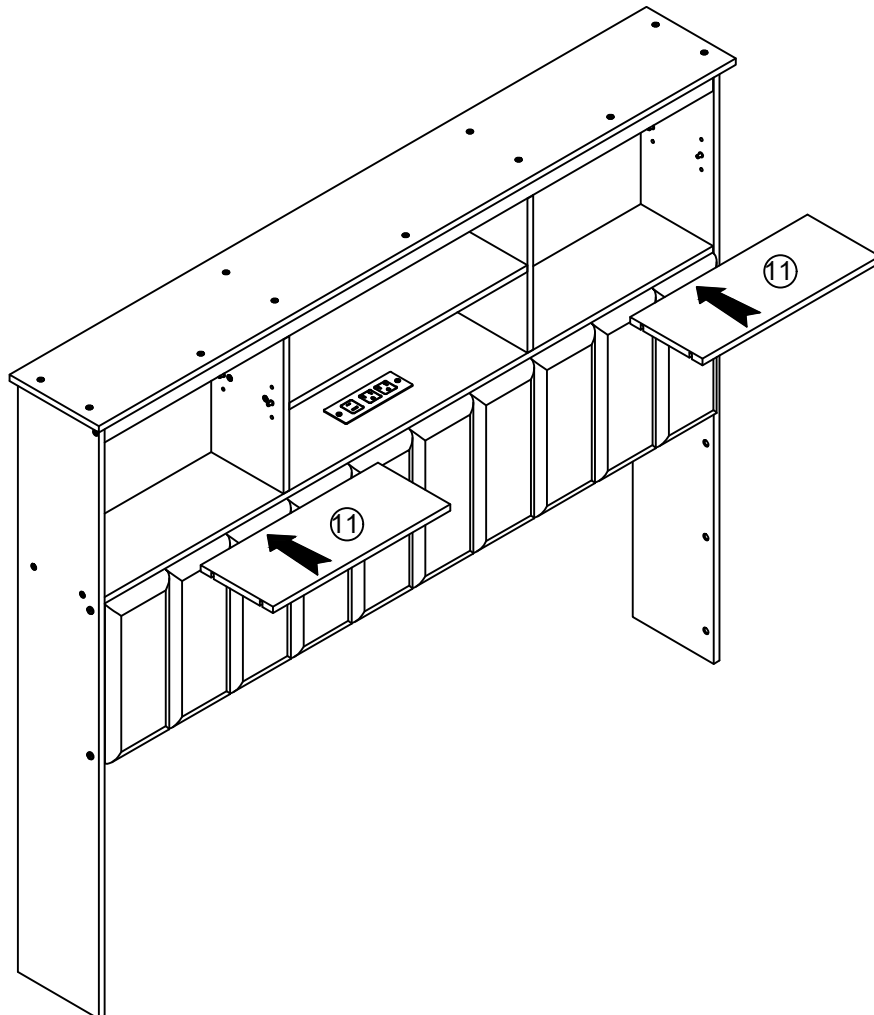

13

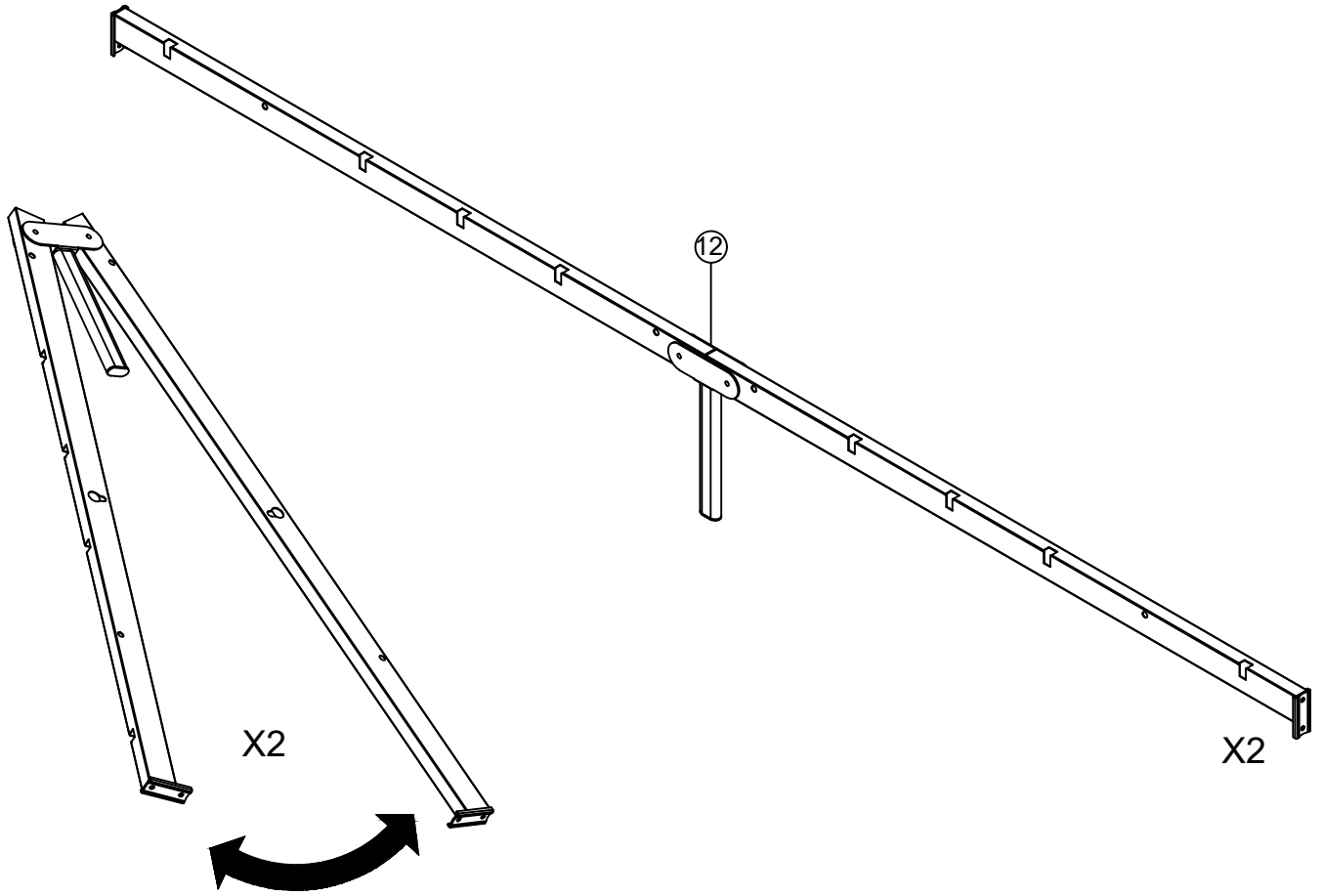

14

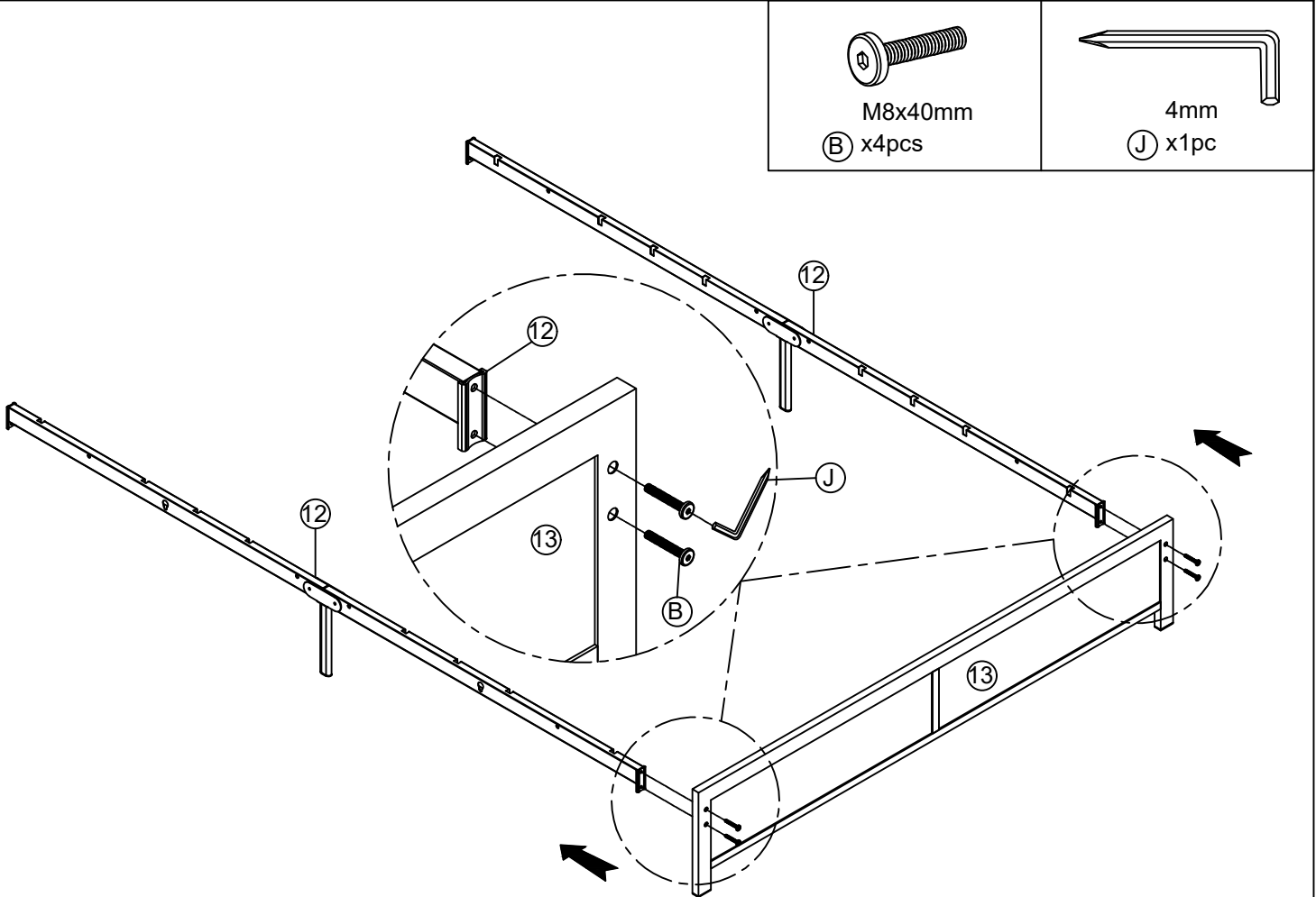

15

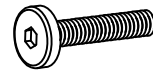

M8x55mm

(A) x4pcs

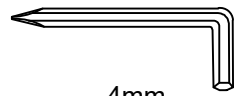

4mm

(J) x1pc

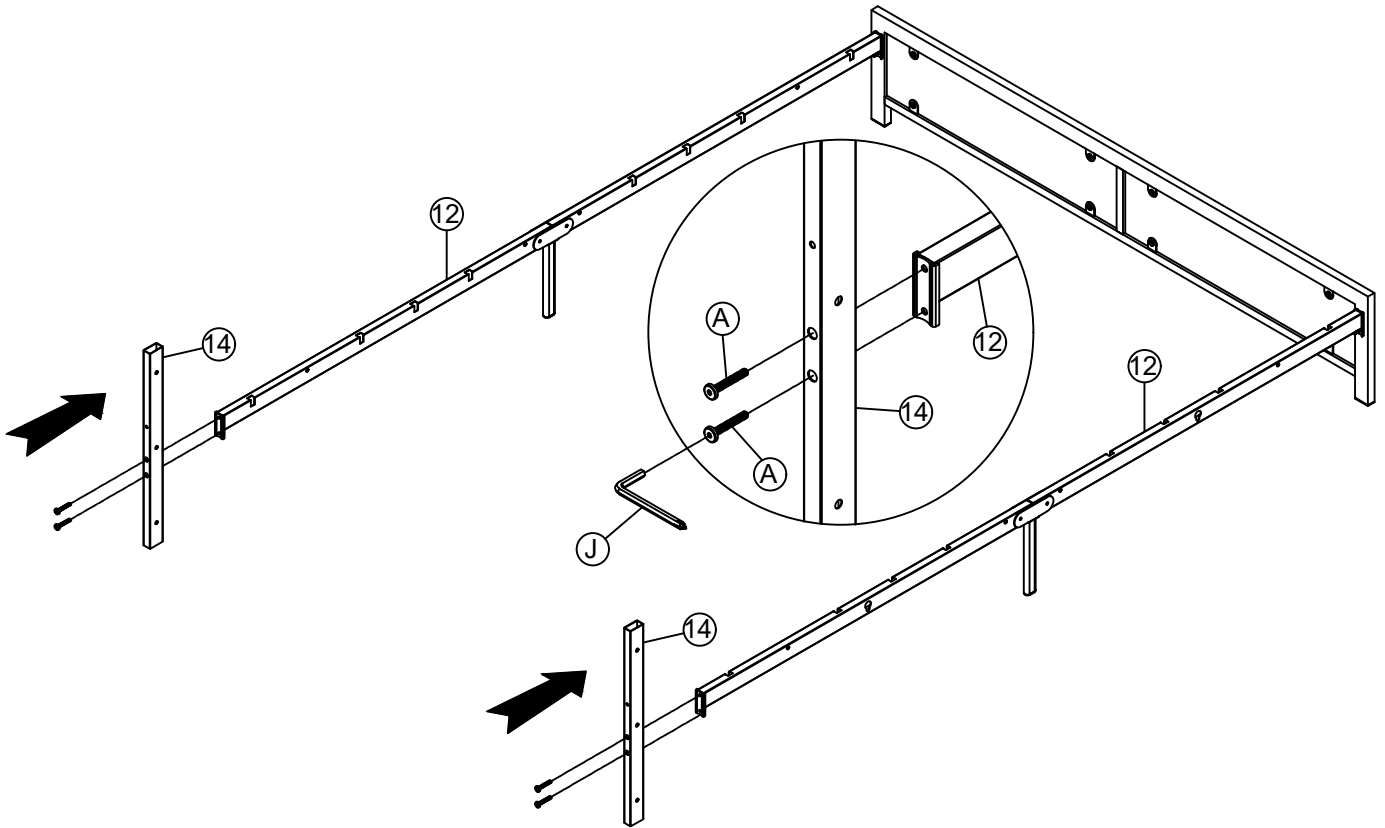

16

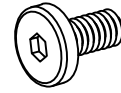

M6x10mm

(D) x2pcs

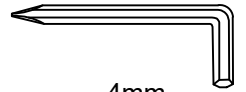

4mm

(J) x1pc

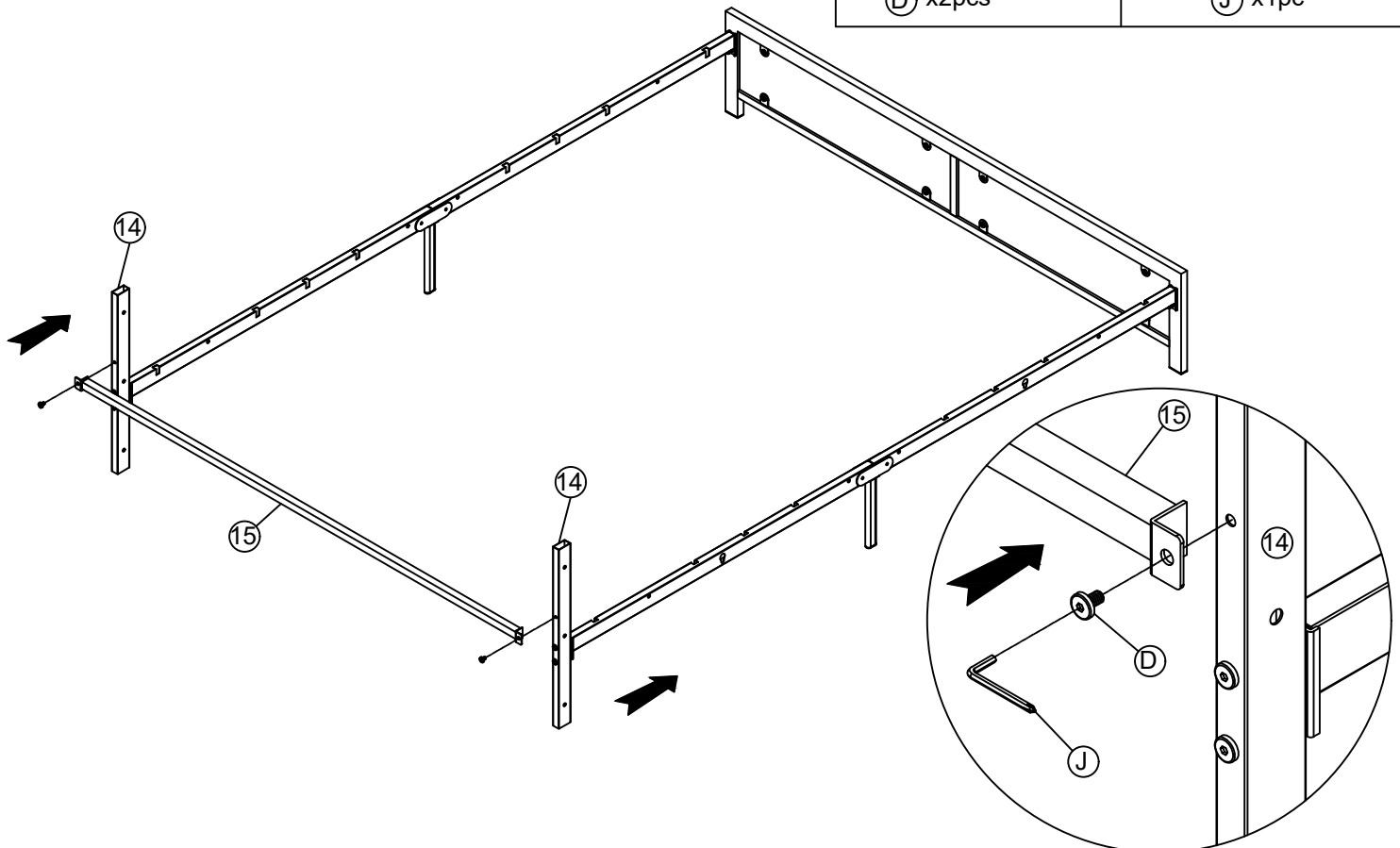

17

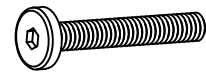

M6x50mm

C x8pcs



4mm

J x1pc

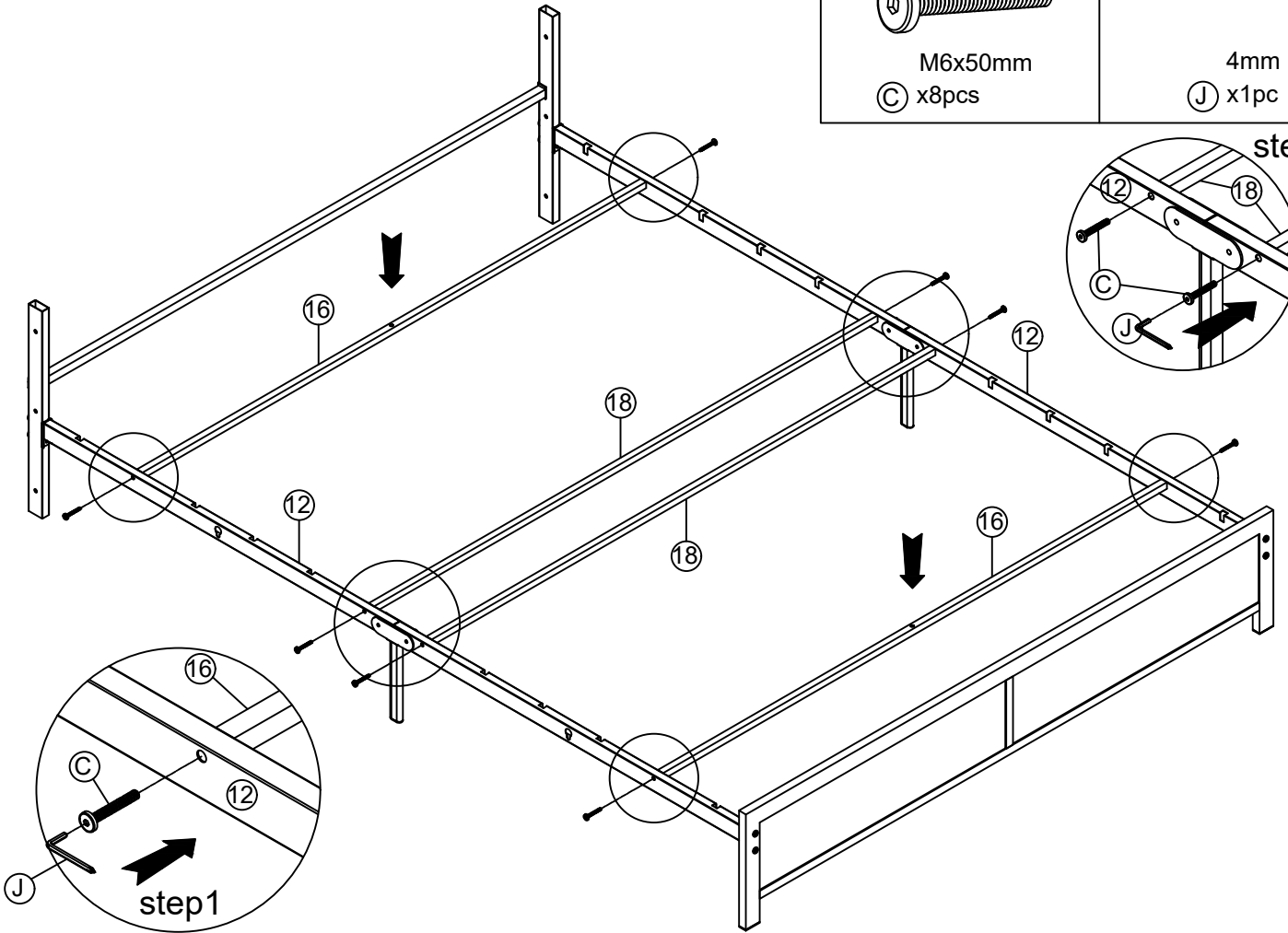

18

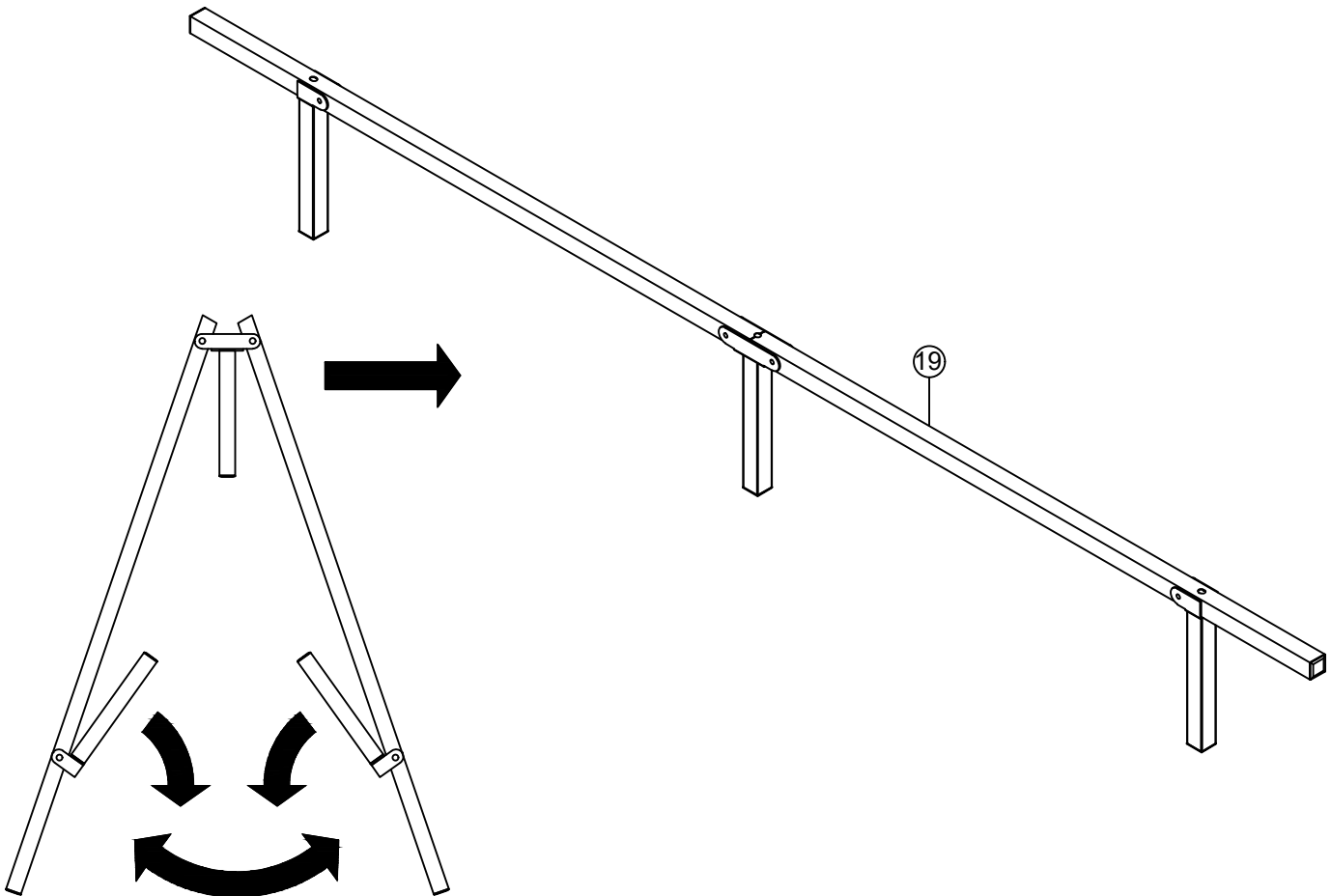

19



(L) x1pc

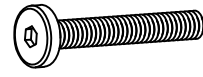

M6x50mm

(C) x3pcs



4mm

(J) x1pc

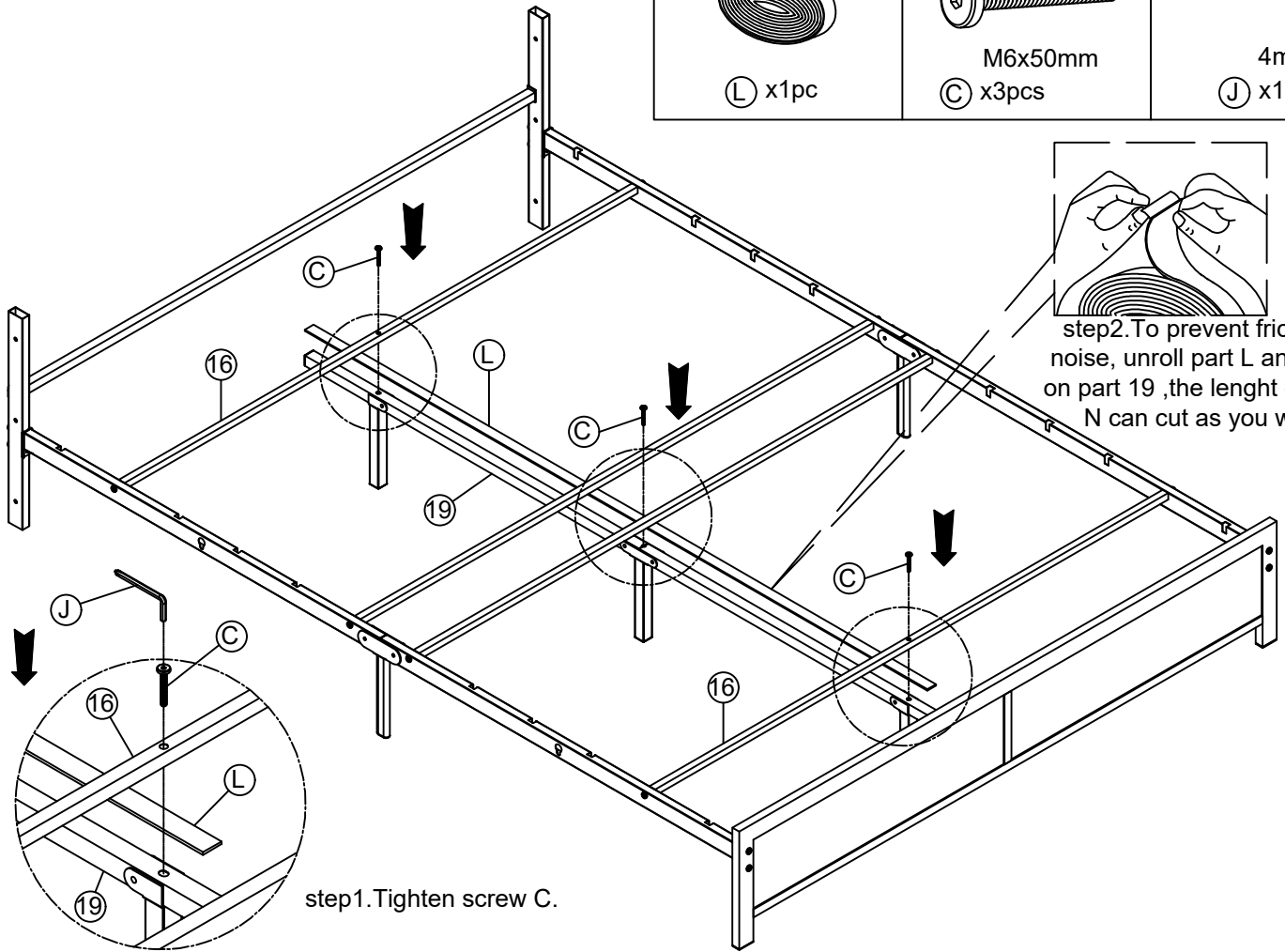

step2. To prevent friction noise, unroll part L and fit it on part 19, the length of part N can cut as you will.

step1. Tighten screw C.

20

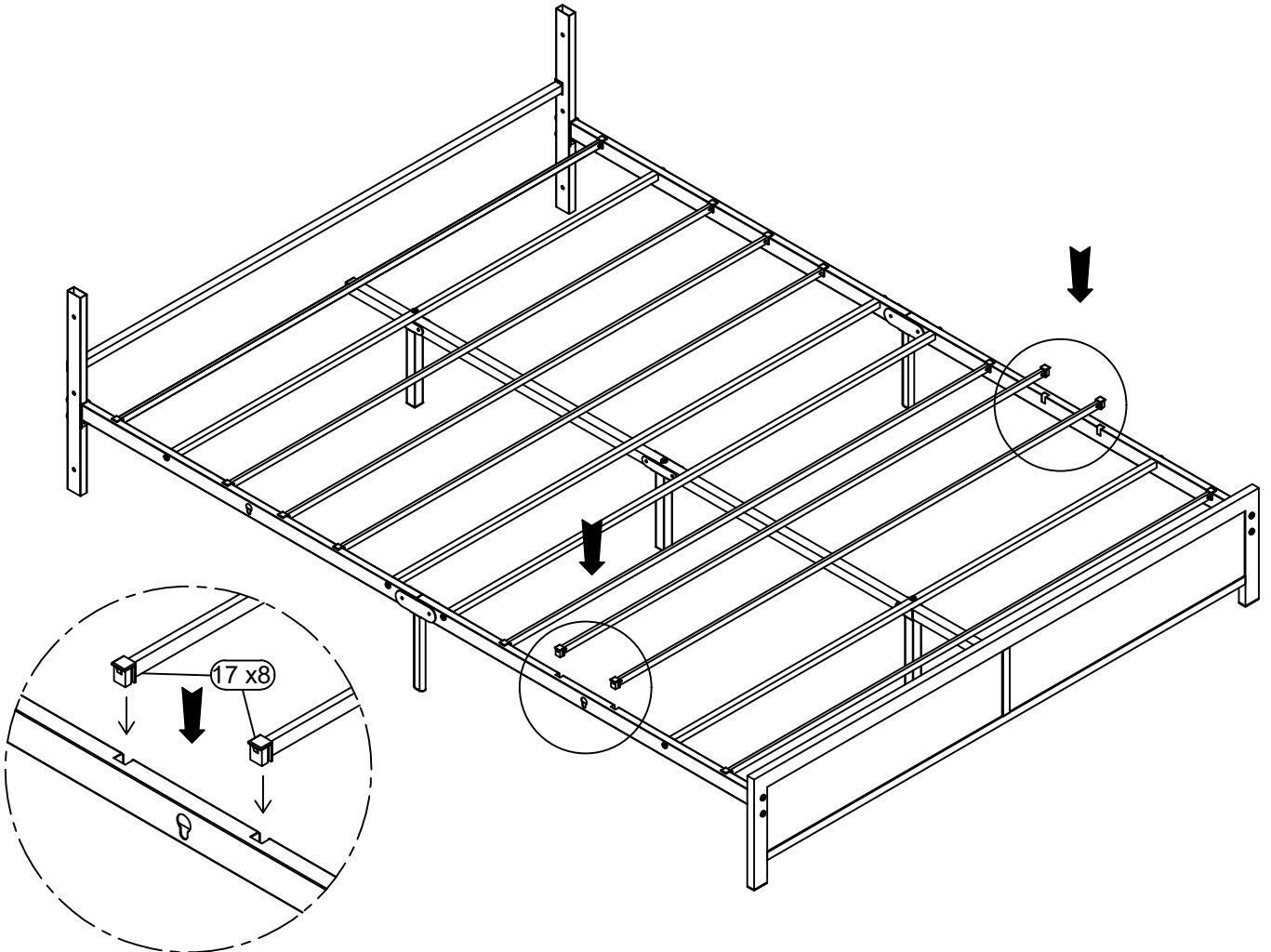

17 x 8

21

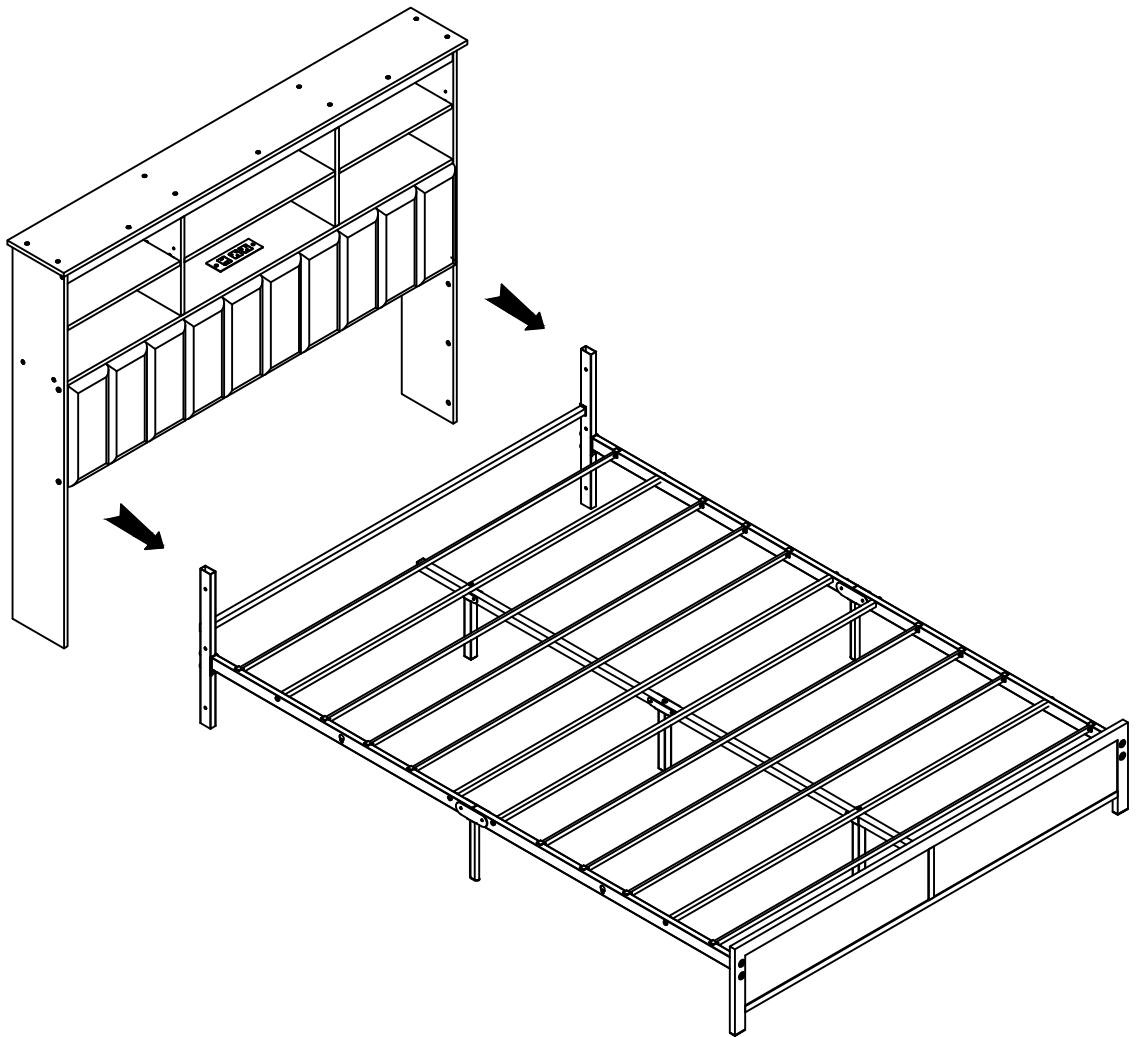

22

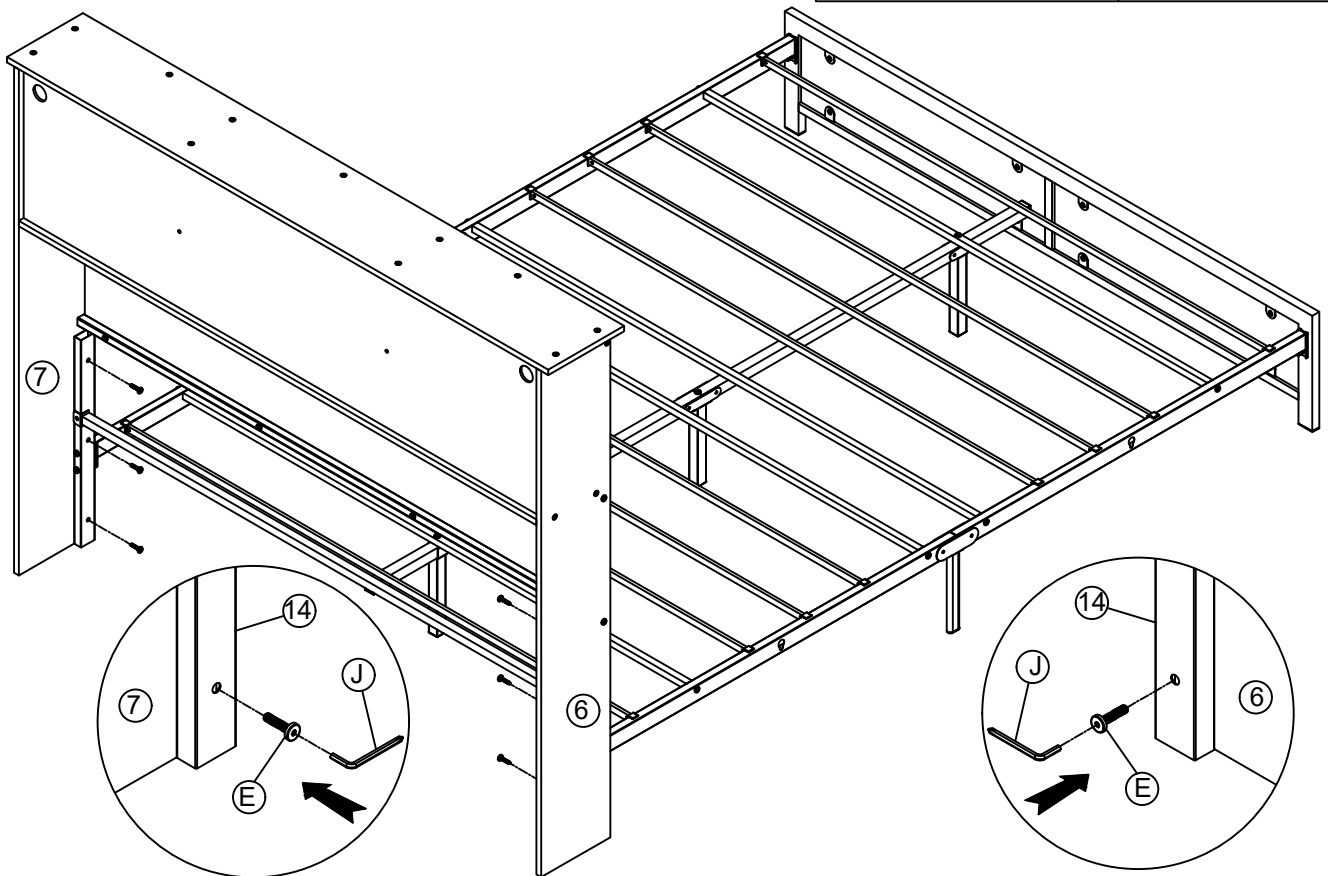
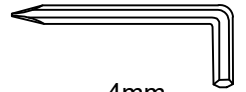
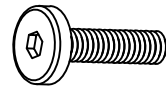

23

Step 1

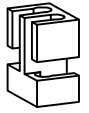

(P) x8pcs

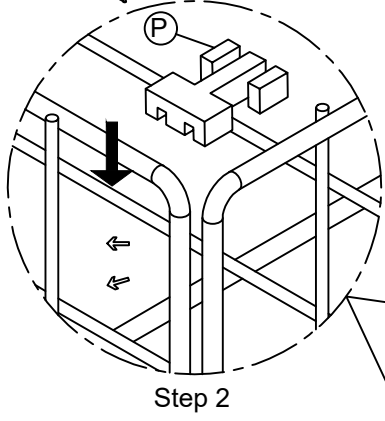
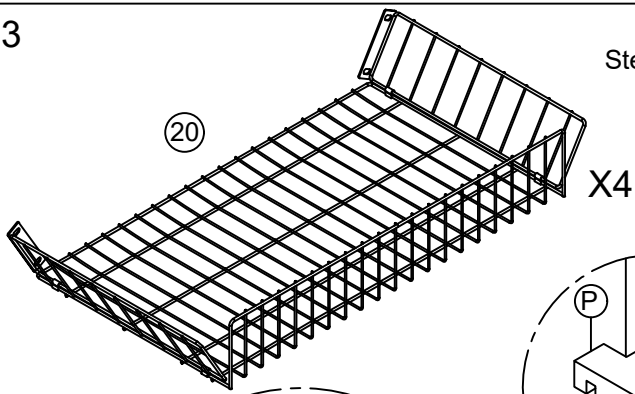

Step 2

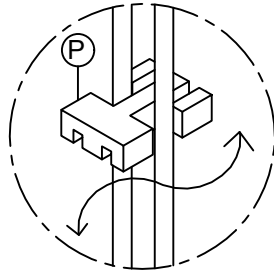

Step 3

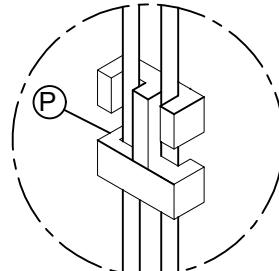

Step 4

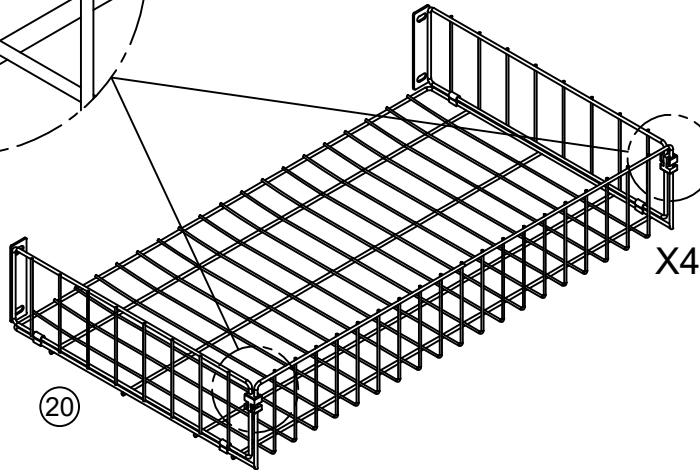

24

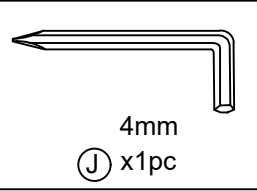

4mm
(J) x1pc

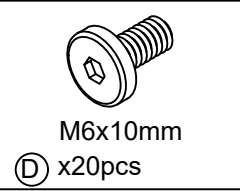

M6x10mm
(D) x20pcs

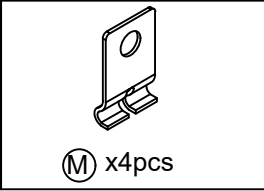

(M) x4pcs

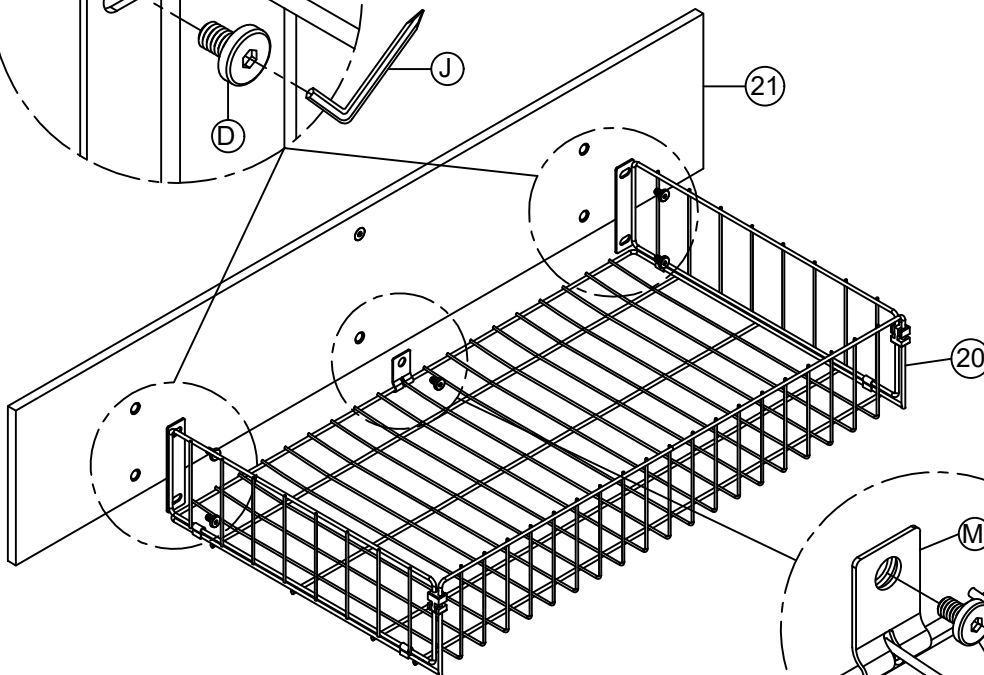
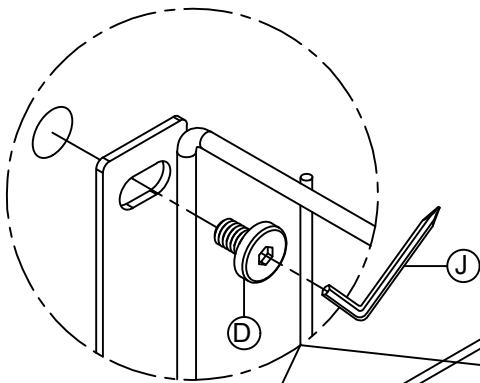

X4

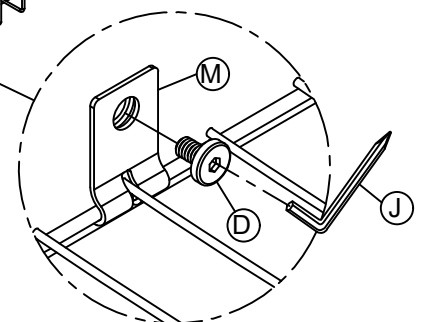

25

Clamp the wire with the opening of the front end of the wheel and press down to tighten the wire.

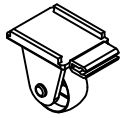

Q x16pcs

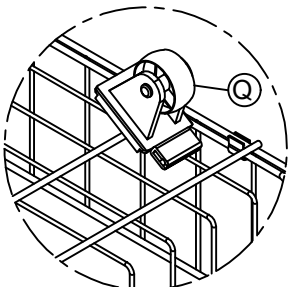

Step 1

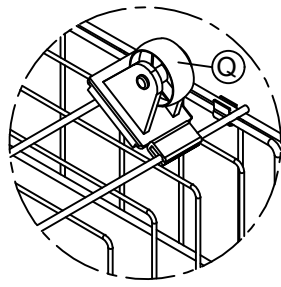

Step 2

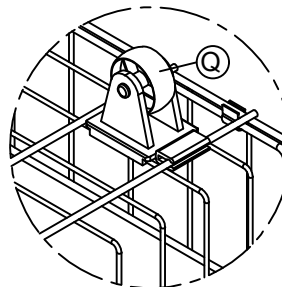

Step 3

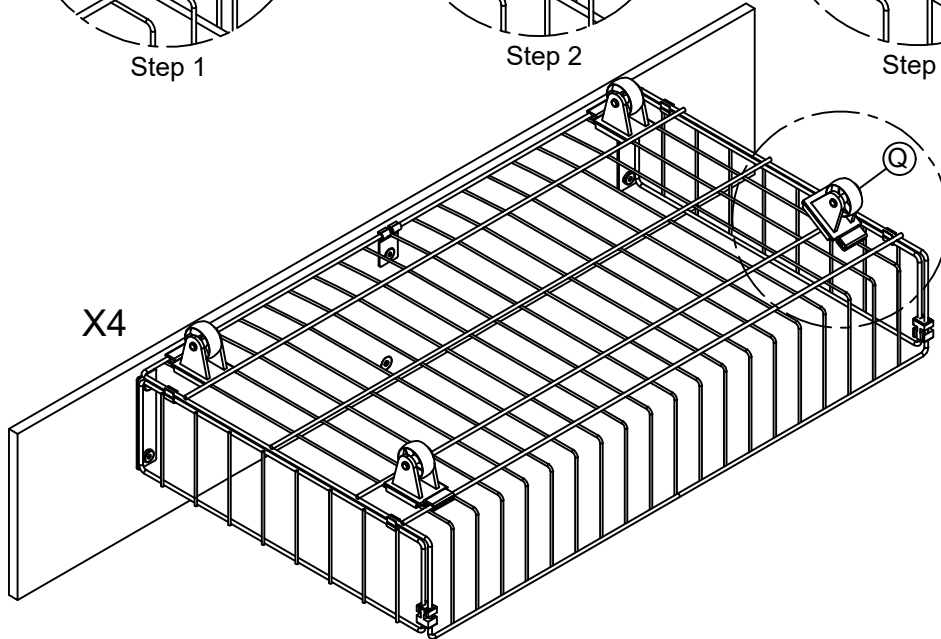

26

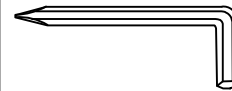

4mm
J x1pc

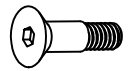

M8x24mm
I x4pcs

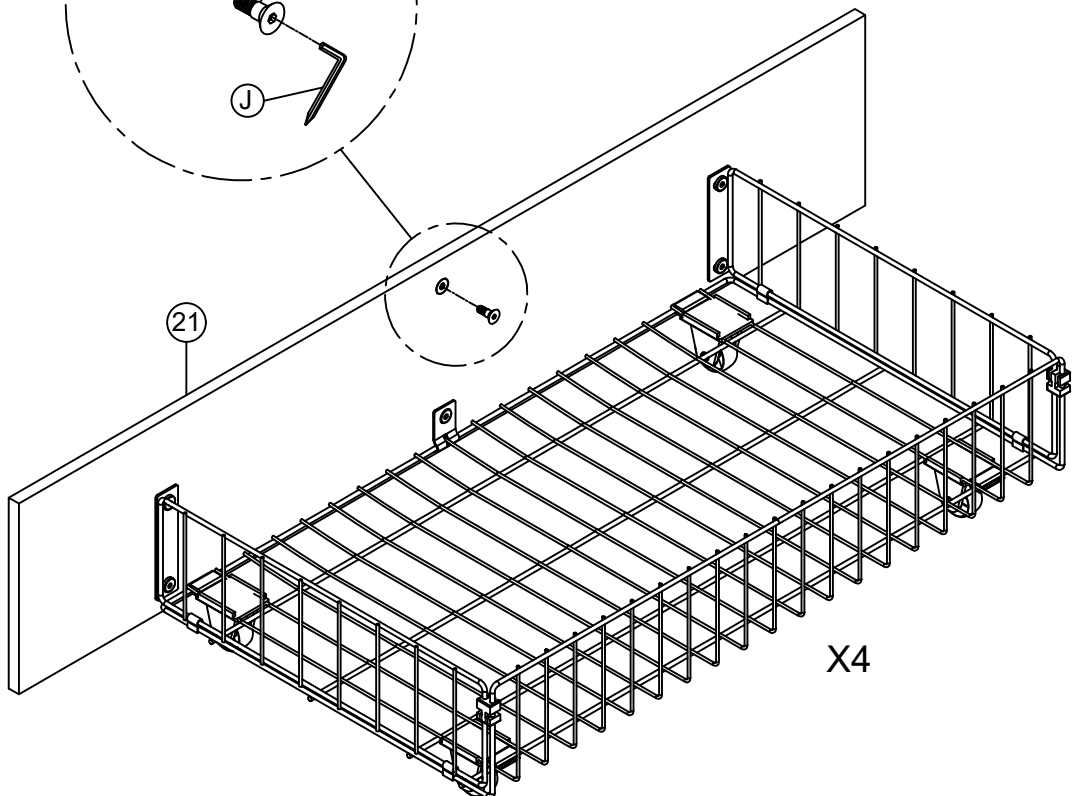
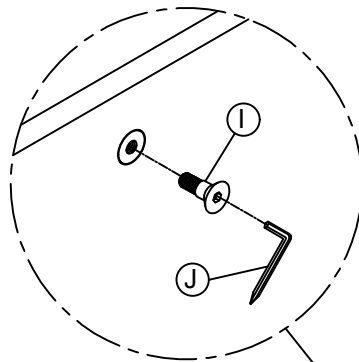

27

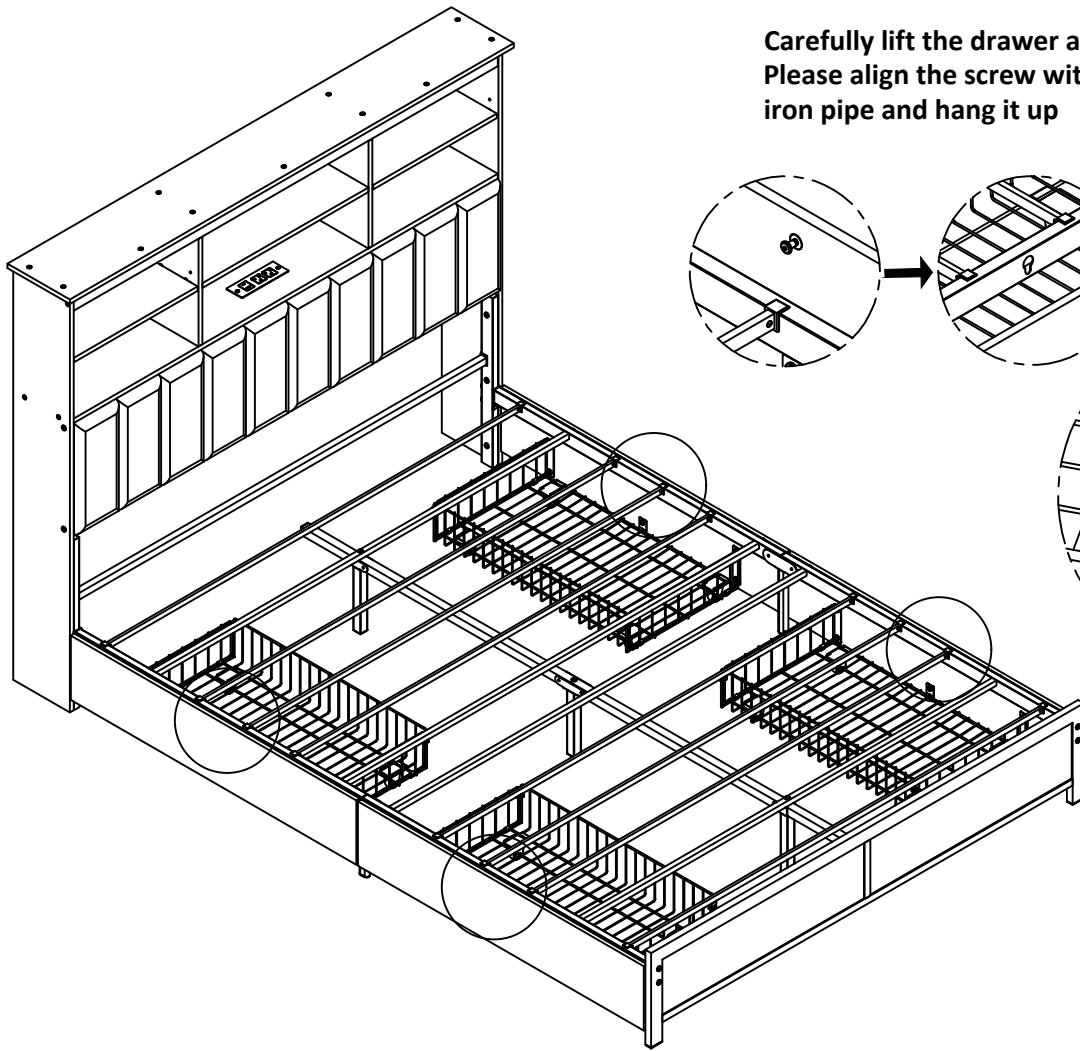

Carefully lift the drawer as you push it in.
Please align the screw with the hole on the
iron pipe and hang it up

28

