

# HONGMAO

---

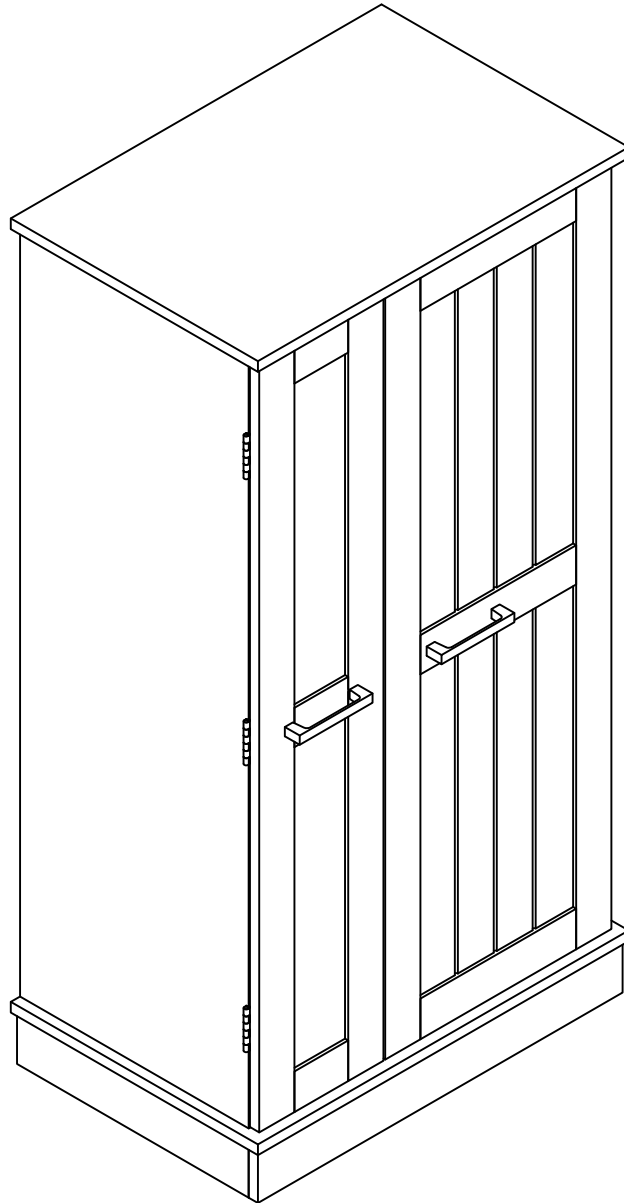

**ITEM NO.HMGG0004**

---

## NOTE:

This brochure contains IMPORTANT safty info. Please read and keep for future reference.

---

# MAINTAINANCE AND WARNING

- 1.Keep furniture away from heat sources.
- 2.Do not clean furniture with harsh cleaner or polishes.Do not use detergents,solvents,abrasives,spray packs or leather cleaner. Use non-color mild soa with warm water to clean spills(Mix 1:10 soap to water).
- 3.Do not place furniture under direct sunlight,material will possibly fade over time.
- 4.Do not use on site dry cleaning machine.Children should not climb or jump on the furniture.
- 5.Do not write on furniture that is not protectedby a padded barrier.
- 6.Not for commercial use,only for residential use.







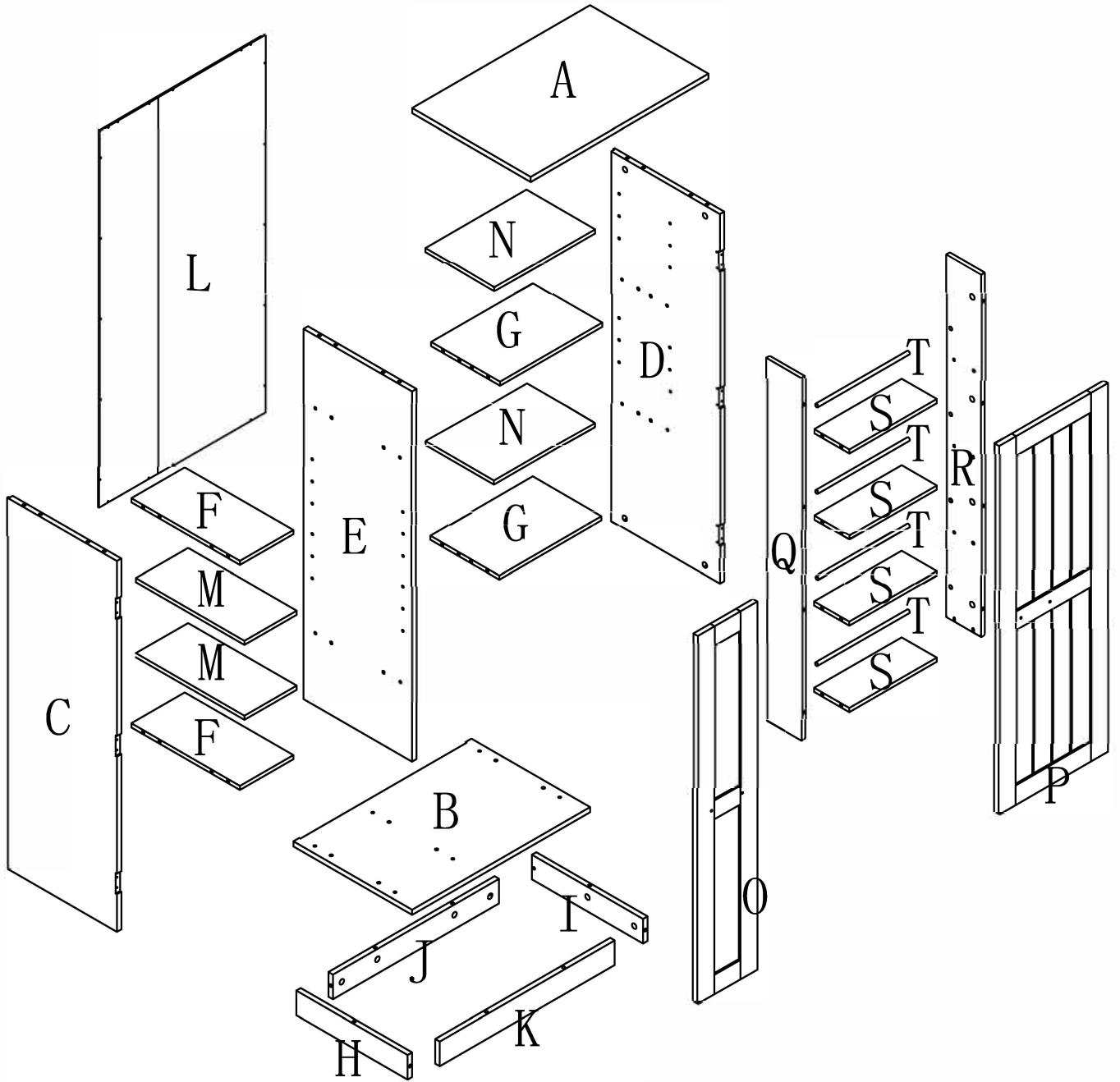



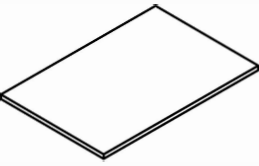
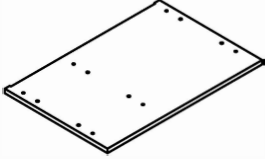

Weight Limitation  
**110 LBS**

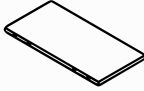
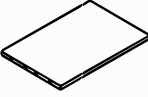
# EXPLOSIVE VIEW

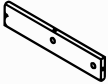
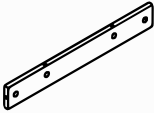
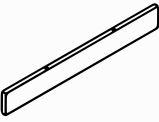

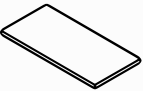
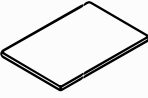

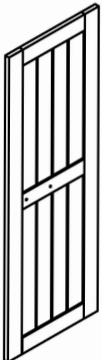



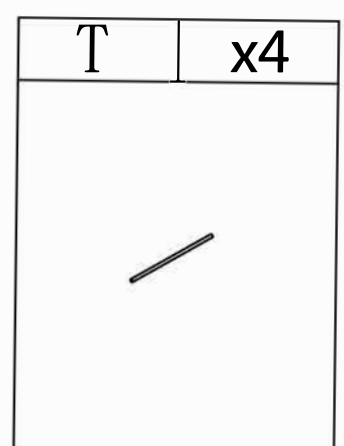
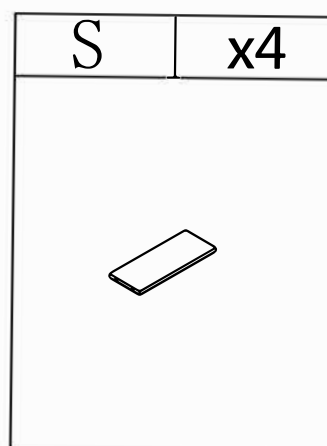
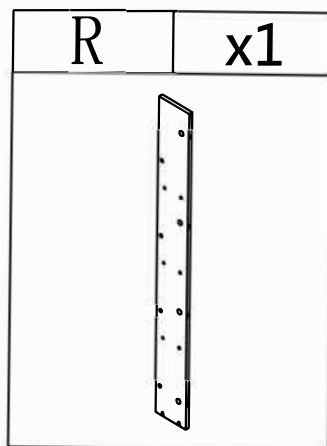
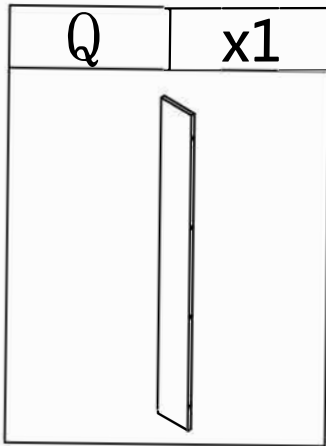

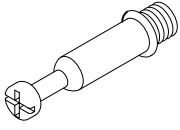
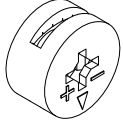
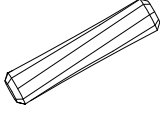
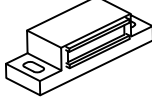
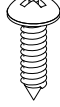

# PARTS LIST

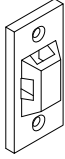
A	x1	B	x1	C	x1	D	x1
							
E	x1	F	x2	G	x2	H	x1
							
I	x1	J	x1	K	x1	L	x1
							
M	x2	N	x2	O	x1	P	x1
							

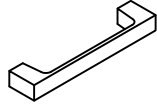
# PARTS LIST

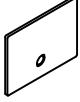

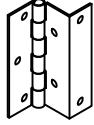
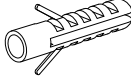
# HARDWARE LIST

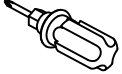
#1	x54		#2	x54		#3	x36		#4	x2		#5	x20		#6	x4	
						ø8*30mm					ø3*14mm*6#						
#7	x4		#8	x4		#9	x16		#10	x2		#11	x4		#12	x2	
ø3*16mm*6#												ø4*22mm					
#13	x44		#14	x6		#15	x4		#16	x4		#17	x2		#18	x1	
ø3.5*14mm*7#								ø3.5*35mm*7#									

# HARDWARE SPARE LIST

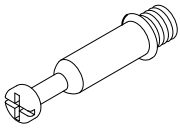
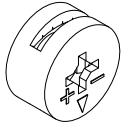
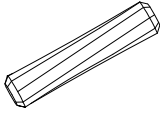
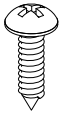
#1	x2		#2	x2		#3	x1		#5	x1	
						ø8*30mm				ø3*14mm*6#	



# ASSEMBLY INSTRUCTIONS

## STEP-2

1. Insert 8x Bolt (#1) into the designated holes on Part (E&D). Tighten Bolt (#1) using Screwdriver (#18).
2. Insert 8x Dowels (#3) into the alignment holes on Part (E&D).
3. Connect Part (E&D) and Part (G) And then Insert 8x Cam locks (#2) into the designated holes on Part (G).using Screwdriver (#18) to lock them.

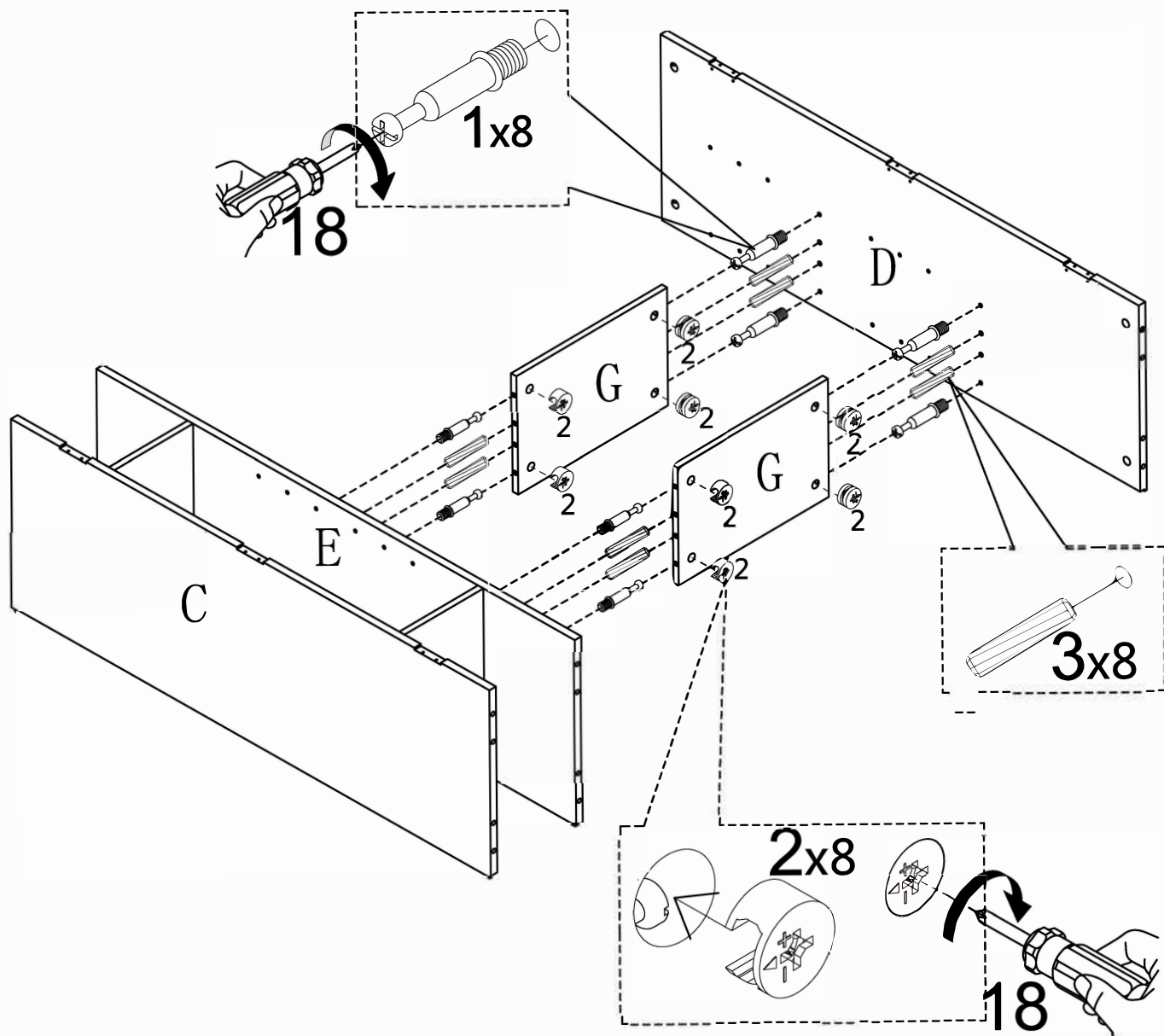

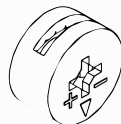
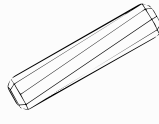
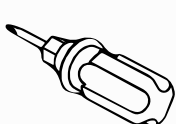
#1	x8	#2	x8	#3	x8	#18	x1
							
				ø8*30mm			



# ASSEMBLY INSTRUCTIONS

## STEP-3

1. Connect part ( H ) & (I) to part (J) using 2x Bolt (#1) into the designated holes on Part (H&I), Insert 2x Cam locks (#2) into the designated holes on Part (J). using Screwdriver (#18) to lock them.

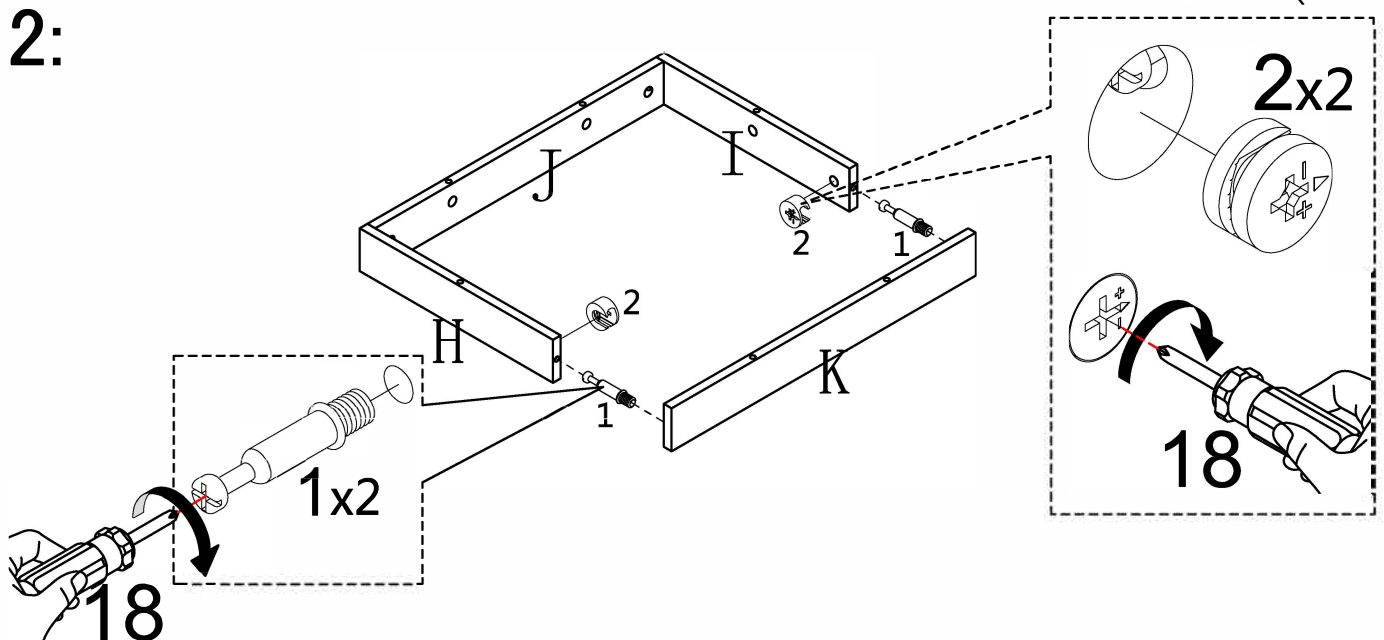
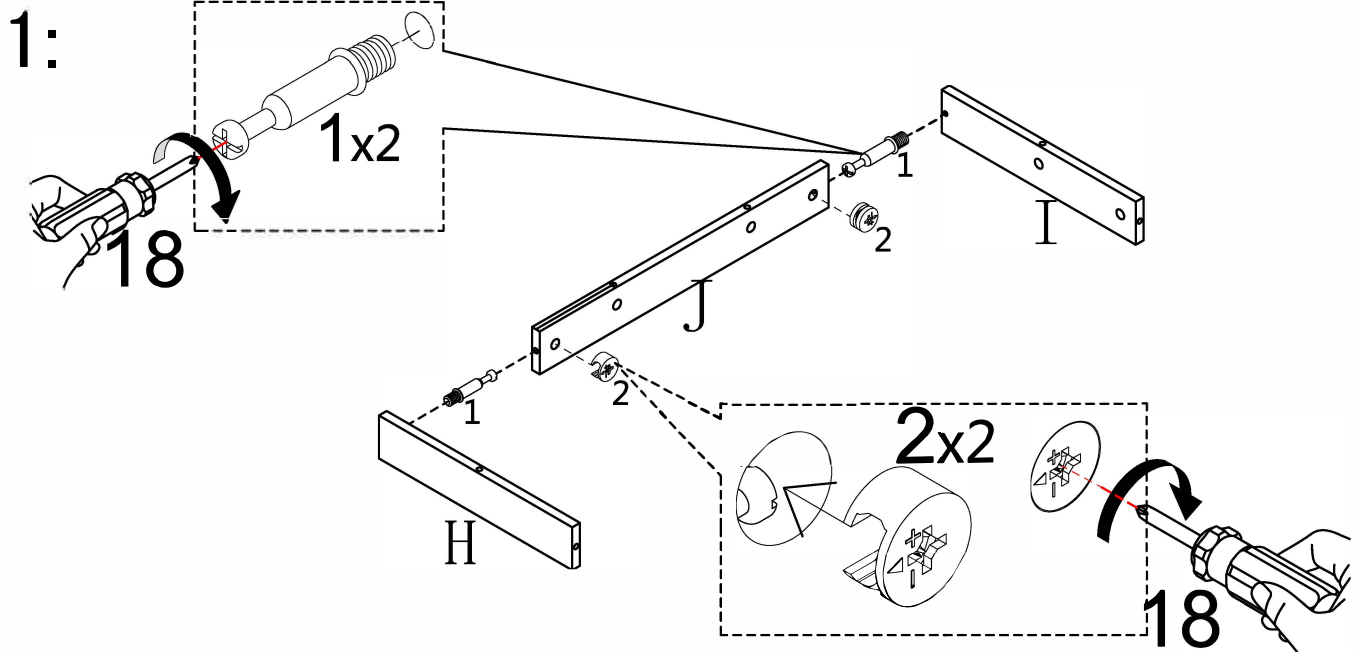
2. Connect part ( K) to part (H&J&I) using 2x Bolt (#1) into the designated holes on Part (K), Insert 2x Cam locks (#2) into the designated holes on Part (H)&(I). using Screwdriver (#18) to lock them.

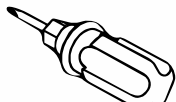

#1	x4	#2	x4	#18	x1
					

# ASSEMBLY INSTRUCTIONS

## STEP-4

- 1.Insert 6x Bolt (#1) into the designated holes on Part (B).Tighten Bolt (#1) using Screwdriver (#18).
- 2.Connect Part (B) and Part (H&I&J&K) Insert 6x Cam locks (#2) into the designated holes on Part (H&I&J&K).using Screwdriver (#18) to lock them.
- 3.Connect 2x Magnetic catch(#4)in to the part (A) and use 4x screw(#5)to attach them,tighten screw (#5) with screwdriver (#18).

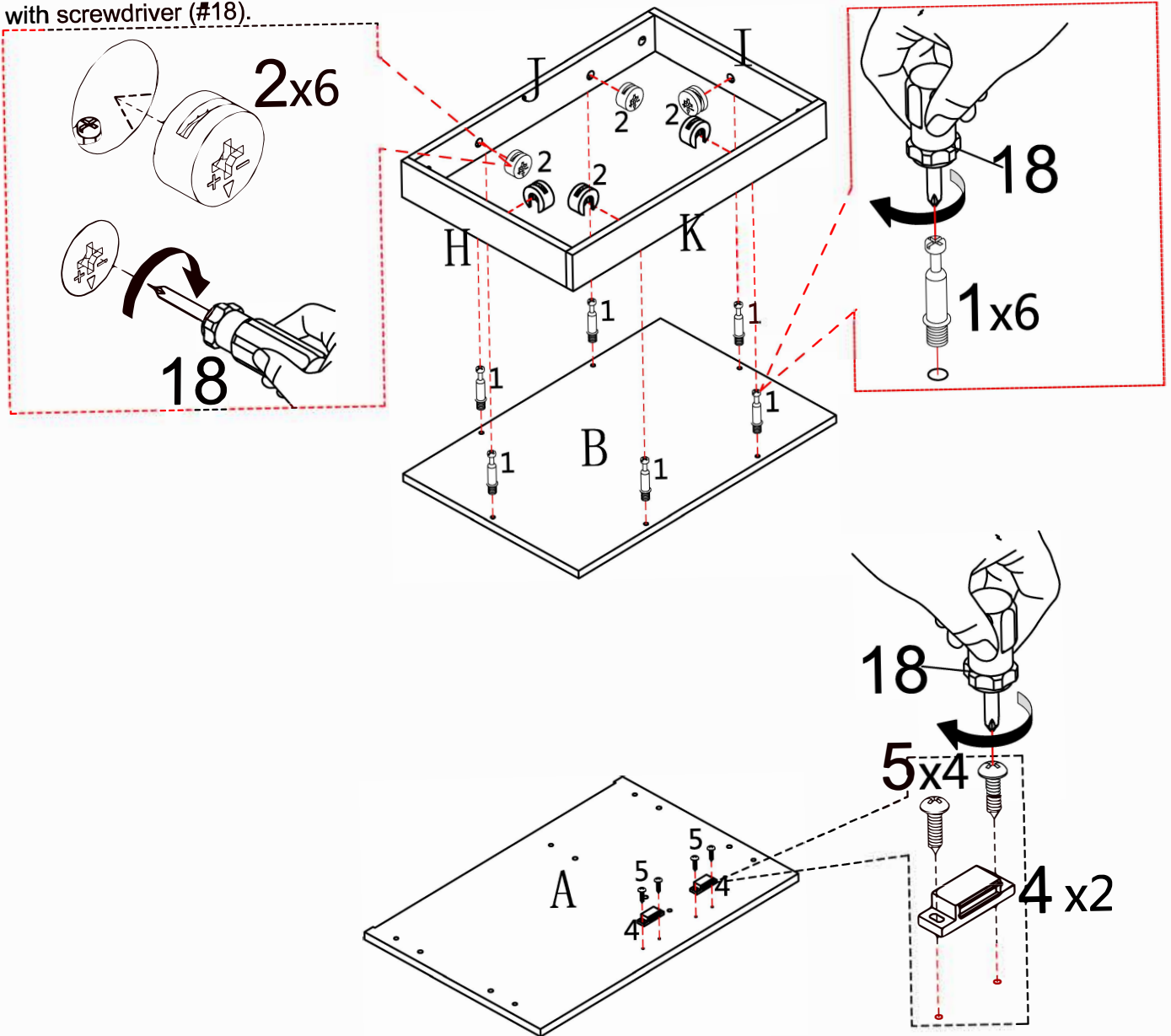



#1	x6	#2	x6	#4	x2	#5	x4	#18	x1
						ø3*14mm*6#			

# ASSEMBLY INSTRUCTIONS

## STEP-5

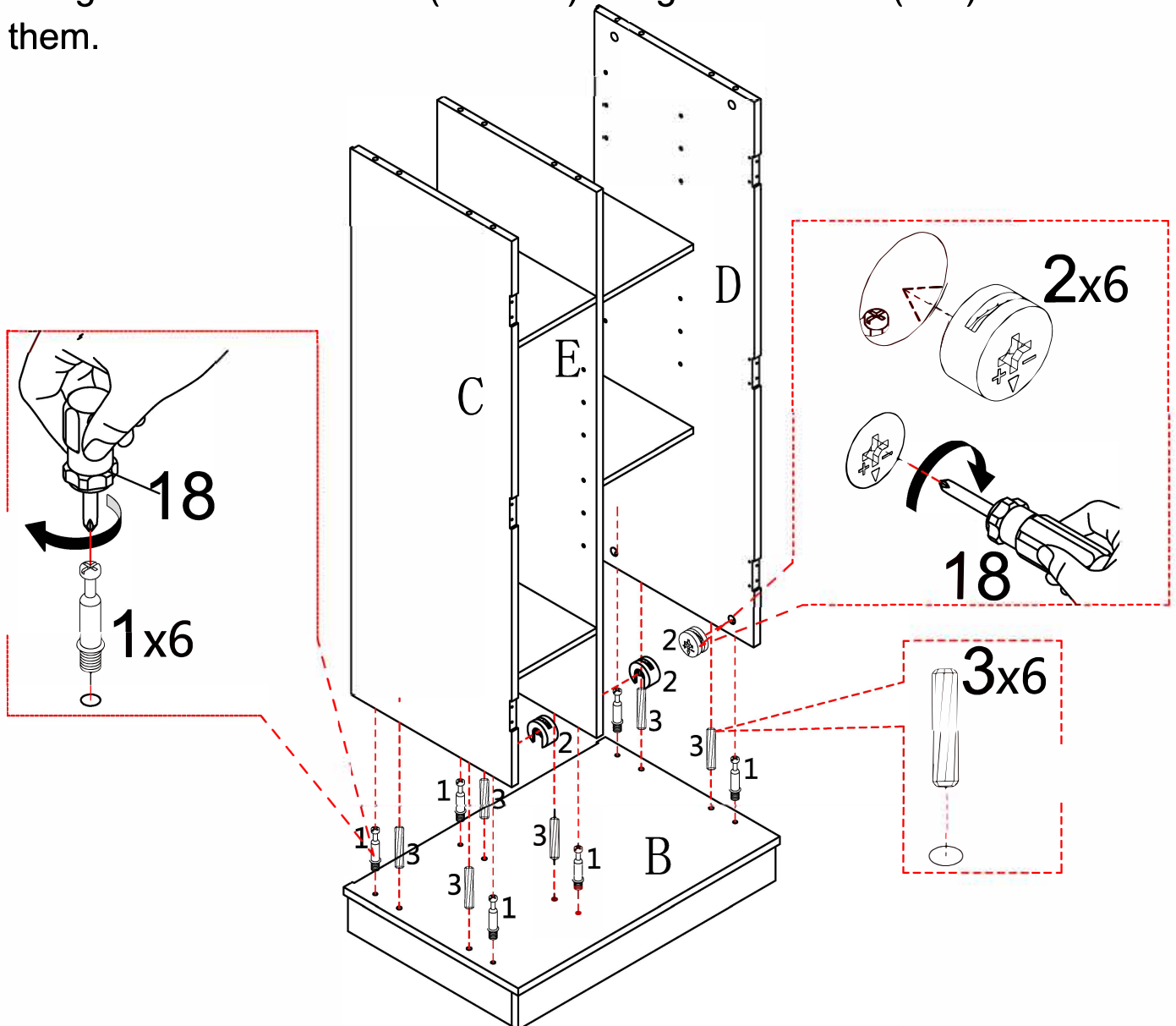
1. Insert 6x Bolt (#1) into the designated holes on Part (B). Tighten Bolt (#1) using Screwdriver (#18).
2. Insert 6x Dowels (#3) into the alignment holes on Part (B).
3. Connect Part (B) and Part (C&E&D) Insert 6x Cam locks (#2) into the designated holes on Part (C&E&D).using Screwdriver (#18) to lock them.

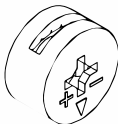

#1	x6
	

#2	x6
	

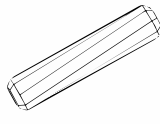
#3	x6
	
ø8*30mm	

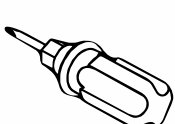
#18	x1
	

# ASSEMBLY INSTRUCTIONS

## STEP-6

1. Insert 6x Bolt (#1) into the designated holes on Part (A). Tighten Bolt (#1) using Screwdriver (#18).
2. Insert 6x Dowels (#3) into the alignment holes on (C&E&D).
3. Connect Part (A) and Part (C&E&D) Insert 6x Cam locks (#2) into the designated holes on Part (C&E&D).using Screwdriver (#18) to lock them.

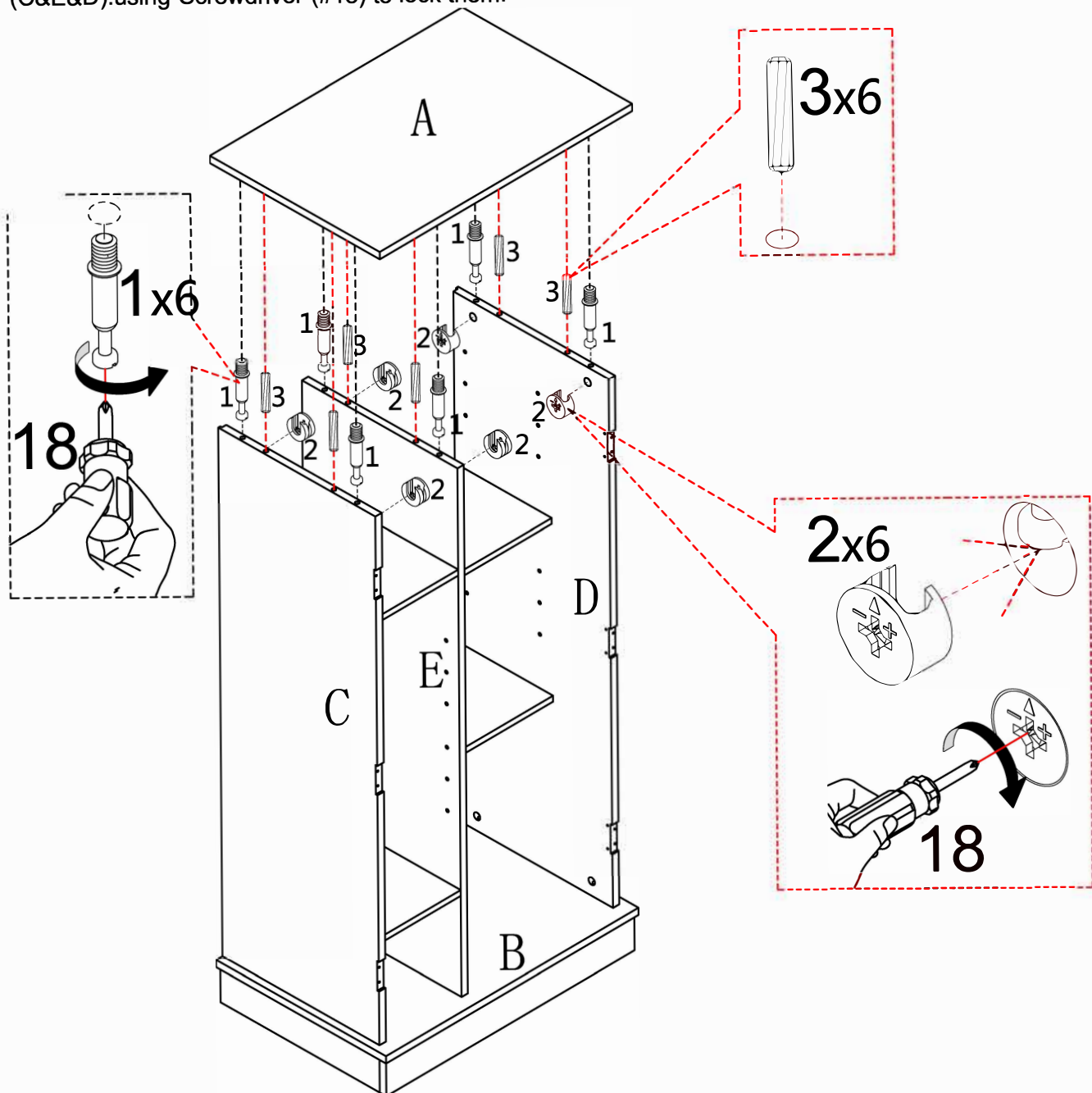

#1	x6
	

#2	x6
	

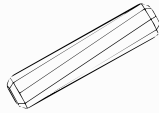
#3	x6
	
φ8*30mm	

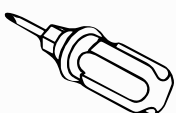
#18	x1
	

# ASSEMBLY INSTRUCTIONS

## STEP-7

1. Insert back panel (L) into the groove of preassembled step 6, make sure all holes aligned and use 16x screw (#5).
2. Insert 2x Part(#8) on the back panel (L) and using 4x screw(#7) to attach them, tighten screw (#7) with screwdriver (#18).

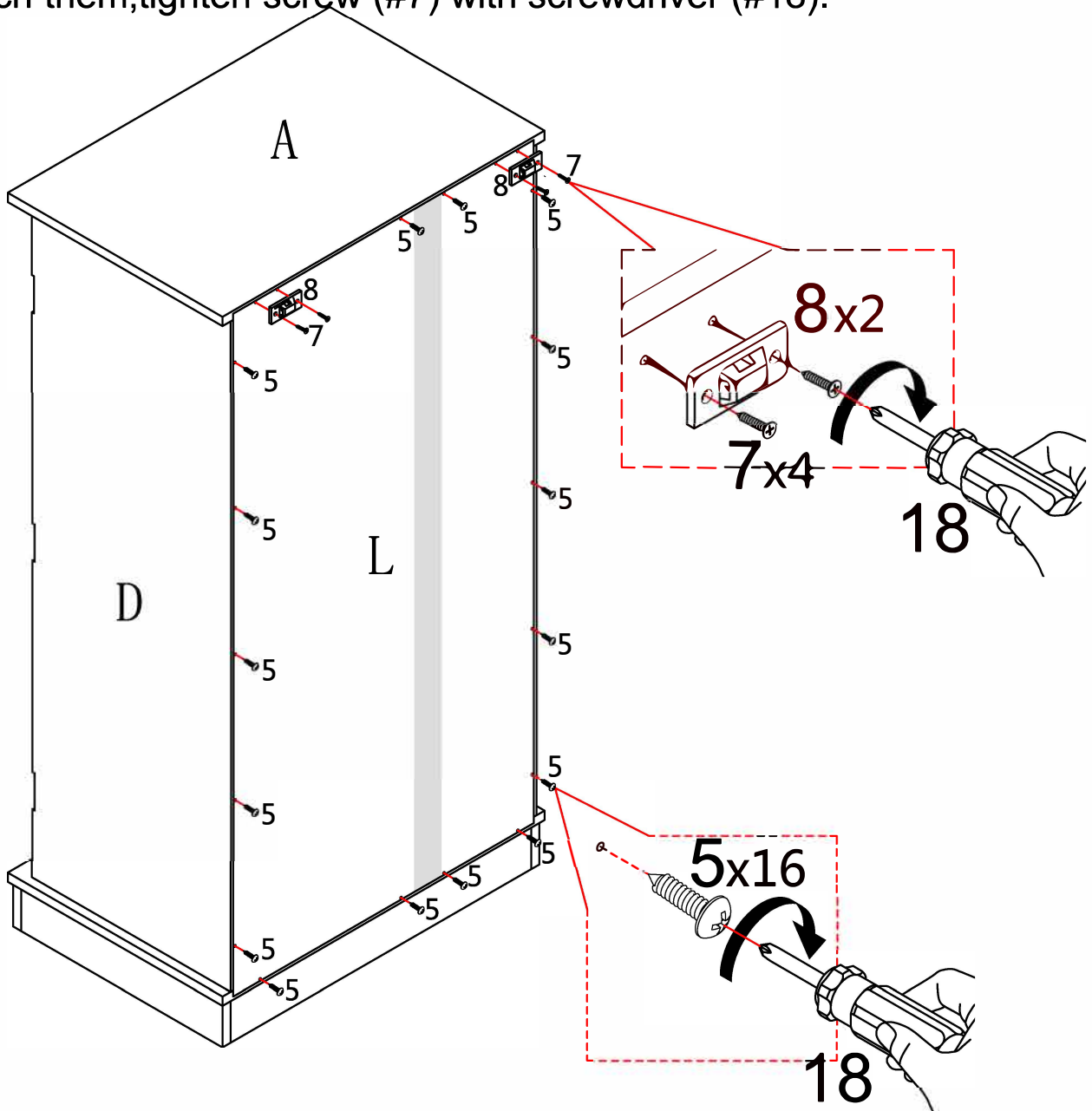

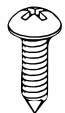
#5	x16
	
φ3*14mm*6#	

#7	x4
	
φ3*16mm*6#	

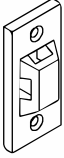
#8	x2
	

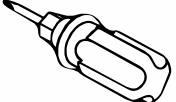
#18	x1
	

# ASSEMBLY INSTRUCTIONS

## STEP-8

1. Push 16x Shelf holder (#9) into the matching holes.
2. Place 2x panel (M) and 2x panel (N) on each top of shelf holder (#9).

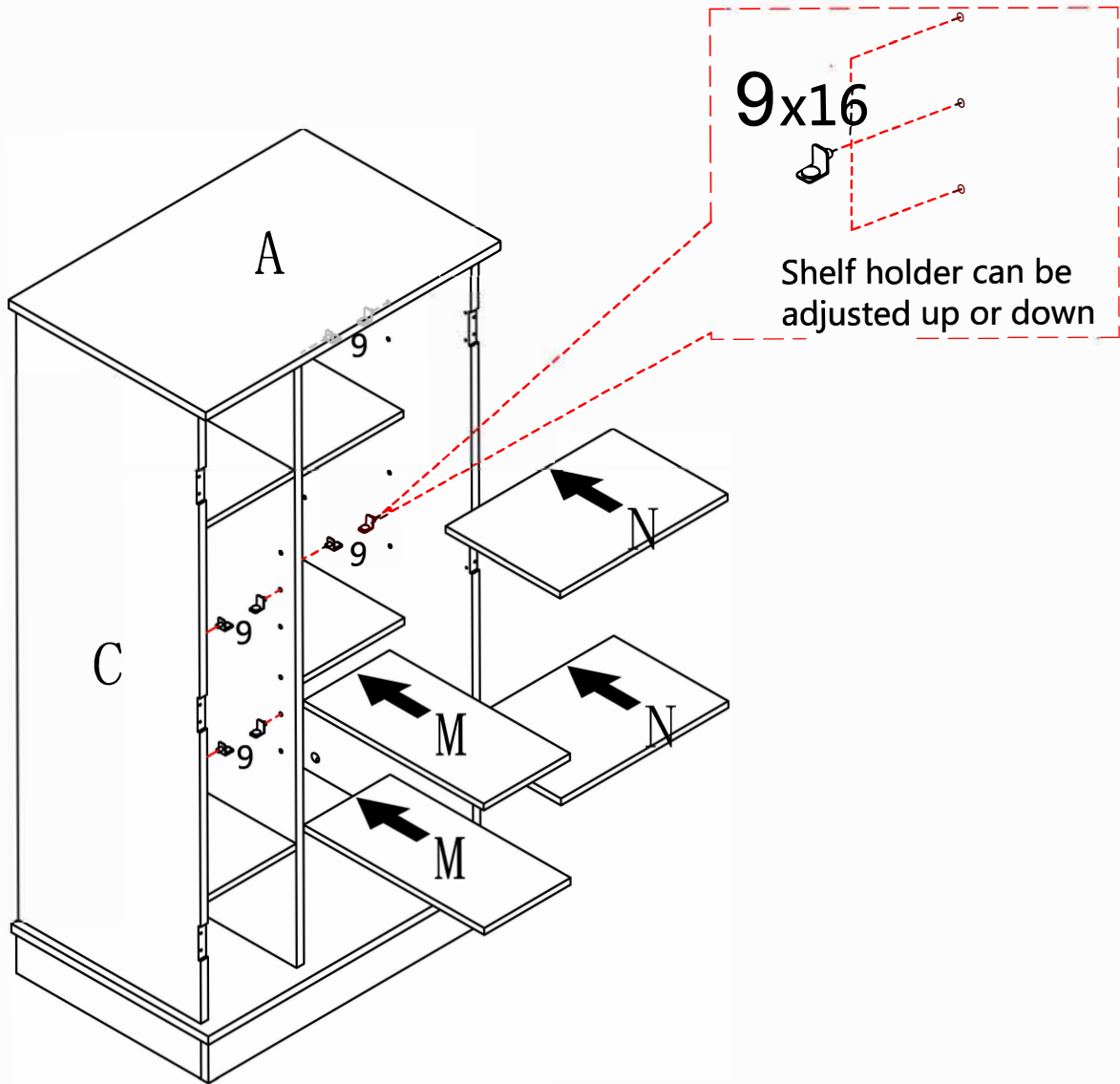

#9	x16

# ASSEMBLY INSTRUCTIONS

## STEP-9

1. Insert 1x Iron plate into the door using 1x screw (#13) to attach them, tighten screw (#13) with screwdriver (#18).

2. Connect 1x door handle on the door insert 2x screw (#11) into the designated holes on the door. using Screwdriver (#18) to tighten them.

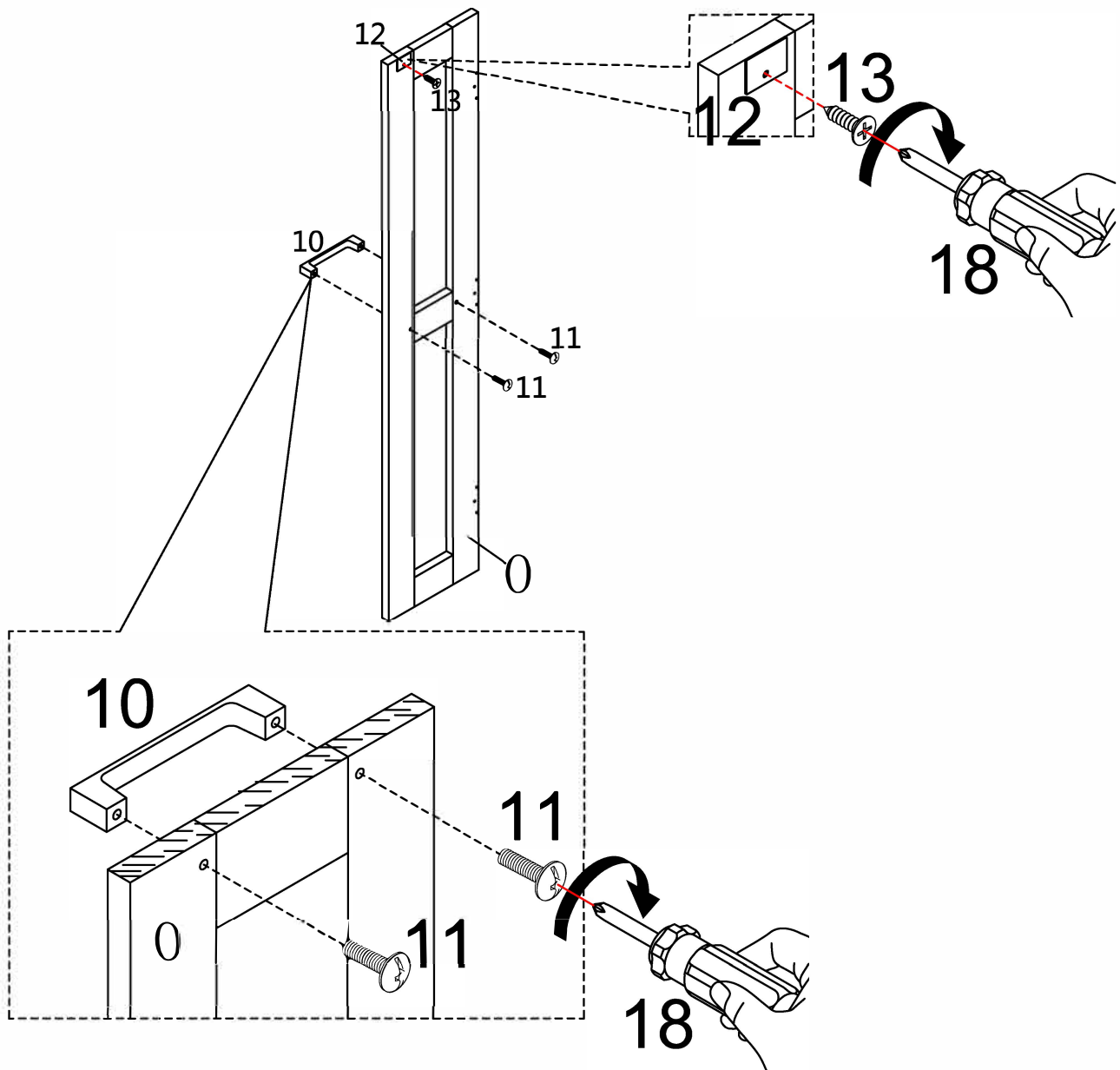

#10	x1

#11	x2
φ4*19mm	

#12	x1

#13	x1
φ3.5*14mm*7#	

#18	x1

# ASSEMBLY INSTRUCTIONS

## STEP-10

1. Move door (0) to corresponding position of side panel, make sure all holes aligned and then insert 3x hinge (#14) use 14x screw (#13) to attach them, tighten screw (#13) with Screwdriver (#18).

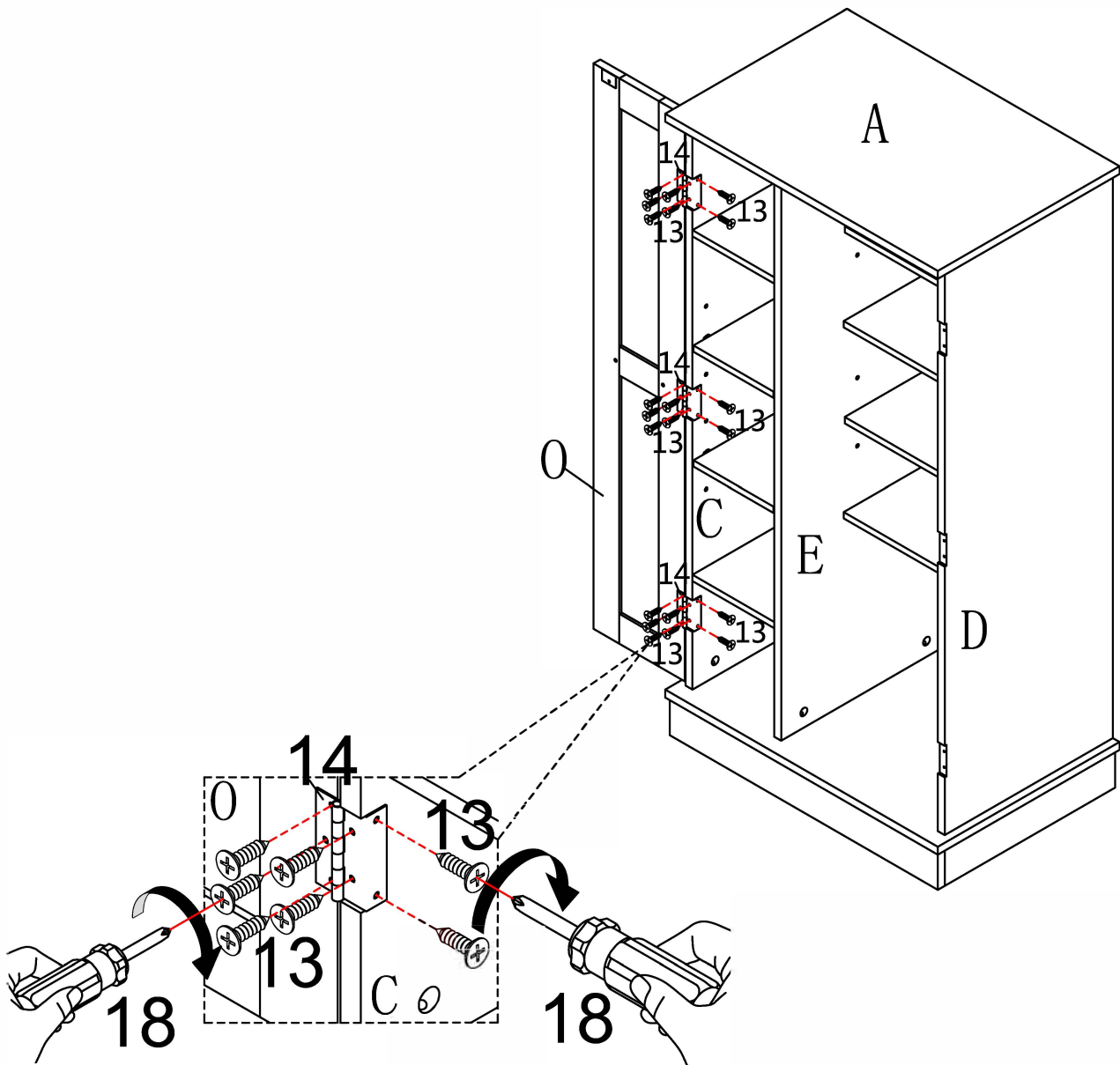

#13	x21
	
ø3.5*14mm*7#	

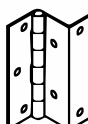
#14	x3
	

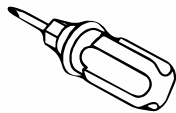
#18	x1
	

# ASSEMBLY INSTRUCTIONS

## STEP-11

1. Insert 8x Bolt (#1) into the designated holes on Part (R&Q). Tighten Bolt (#1) using Screwdriver (#18).
2. Insert 8x Dowels (#3) into the alignment holes on Part (R&Q).
3. Connect Part (R&Q) and Part (S) Insert 8x Cam locks (#2) into the designated holes on Part (S).using Screwdriver (#18) to lock them.

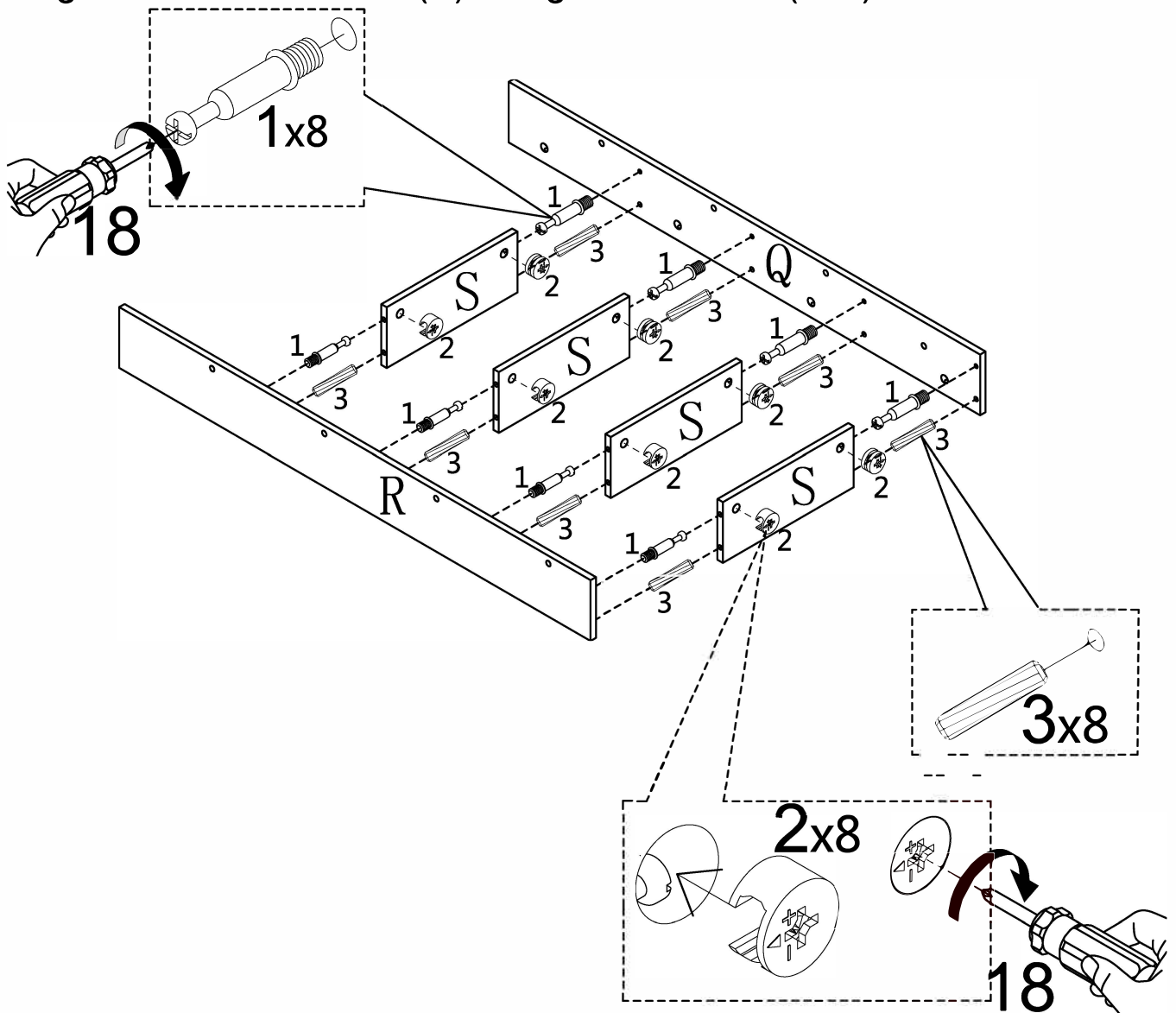

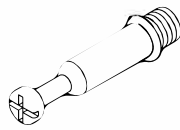
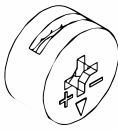
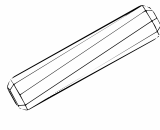
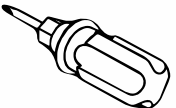
#1	x8	#2	x8	#3	x8	#18	x1
							
				ø8*30mm			



# ASSEMBLY INSTRUCTIONS

## STEP-12

1. Insert 8x Bolt (#1) into the designated holes on Part (P). Tighten Bolt (#1) using Screwdriver (#18).

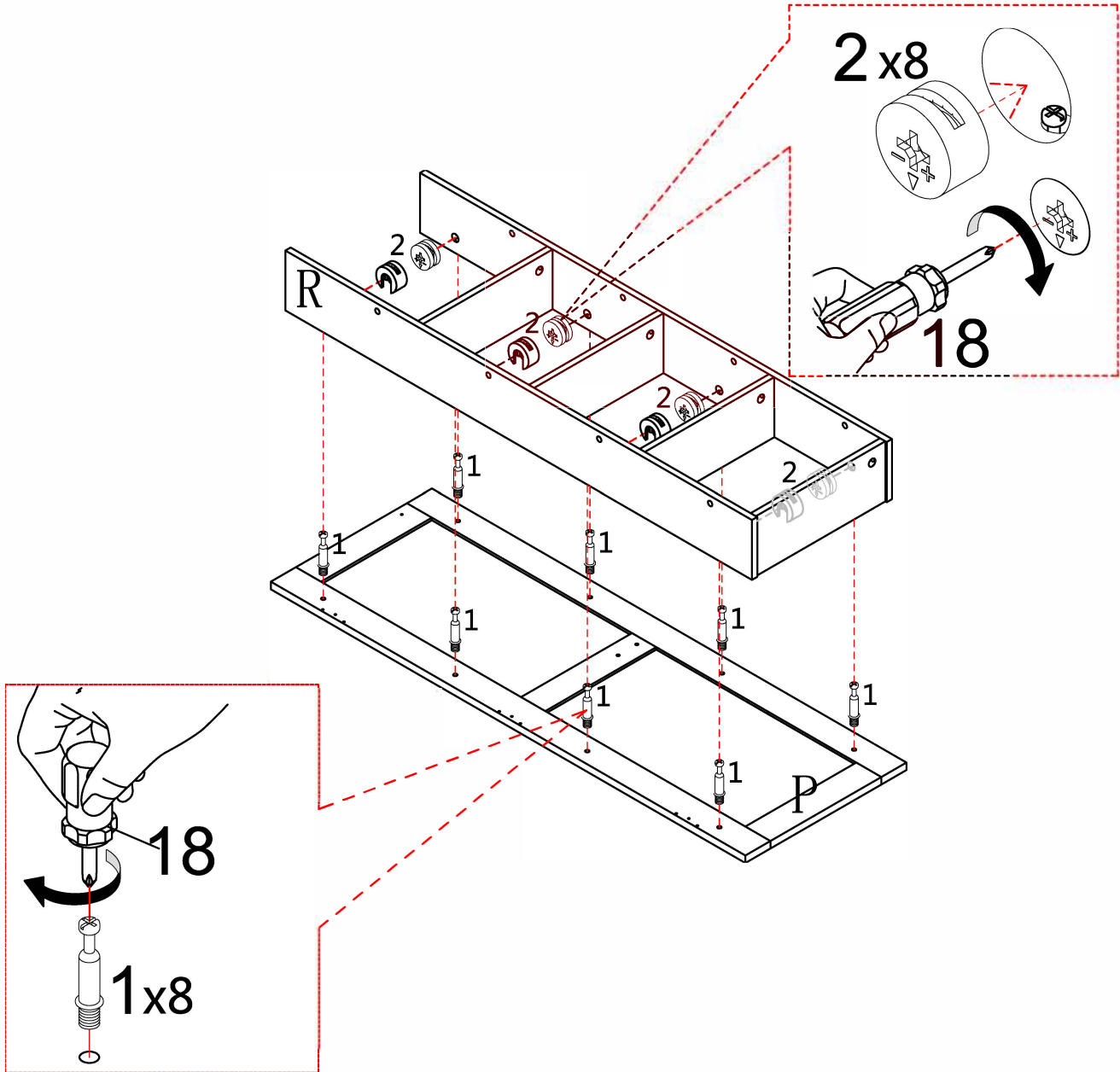
2. Connect Part (P) and Part (R) Insert 8x Cam locks (#2) into the designated holes on Part (R).using Screwdriver (#18) to lock them.

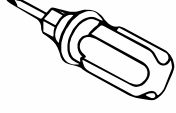

#1	x8	#2	x8	#18	x1
					

# ASSEMBLY INSTRUCTIONS

## STEP-13

1. Insert 4x stopper (#6) on the top of the stick (T), And push the stick in the designated holes.

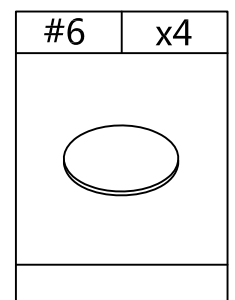
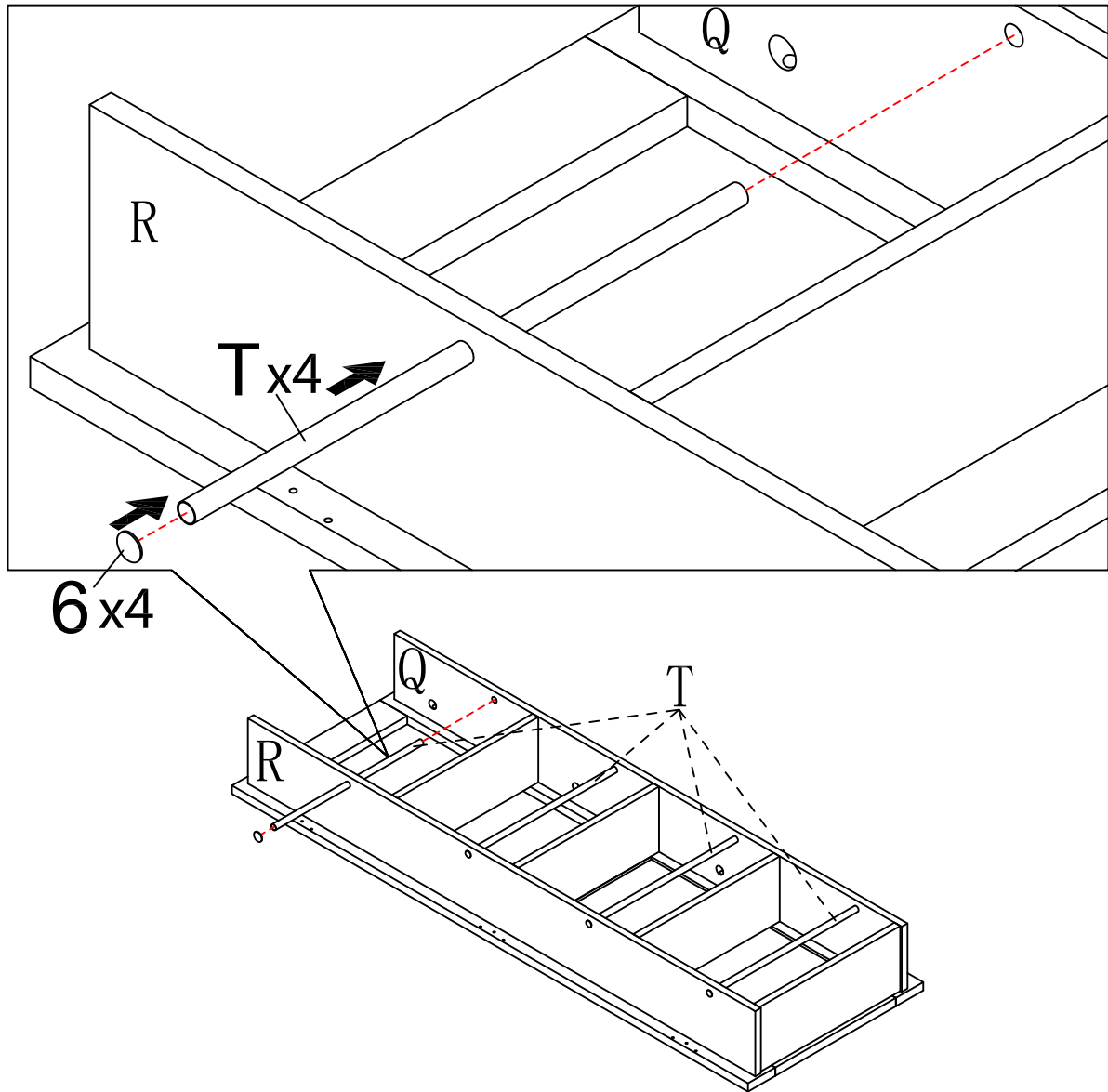

# ASSEMBLY INSTRUCTIONS

## STEP-14

1. Insert 1x Iron plate into the door using 1x screw (#13) to attach them, tighten screw (#13) with screwdriver (#18).

2. Connect 1x door handle on the door insert 2x screw (#11) into the designated holes on the door. using Screwdriver (#18) to tighten them.

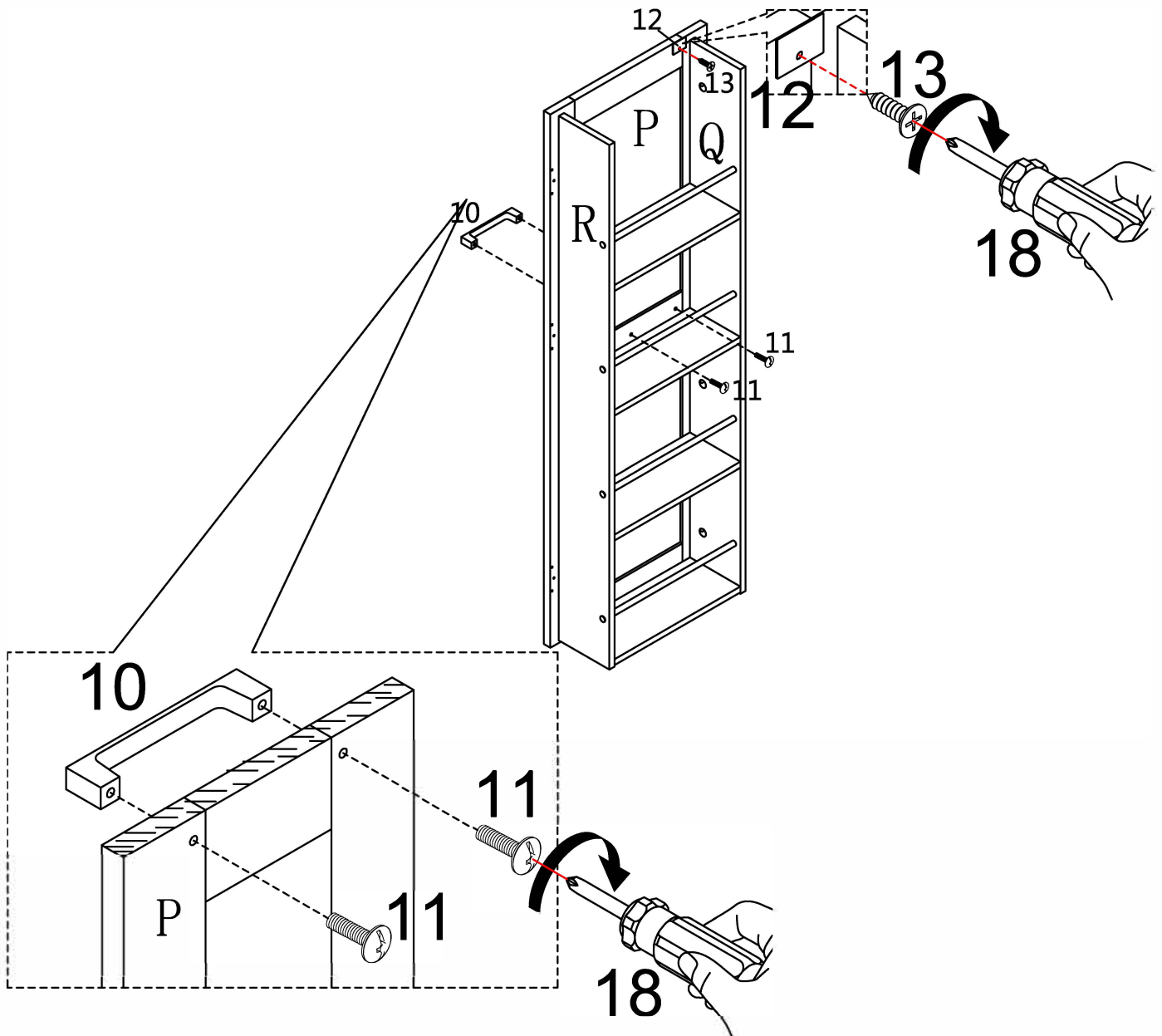

#10	x1

#11	x2
ø4*19mm	

#12	x1

#13	x1
ø3.5*14mm*7#	

#18	x1

# ASSEMBLY INSTRUCTIONS

## STEP-15

1. Move door (P&Q) to corresponding position of side panel, make sure all holes aligned and then insert 3x hinge (#14) use 21x screw (#13) to attach them, tighten screw (#13) with Screwdriver (#18).

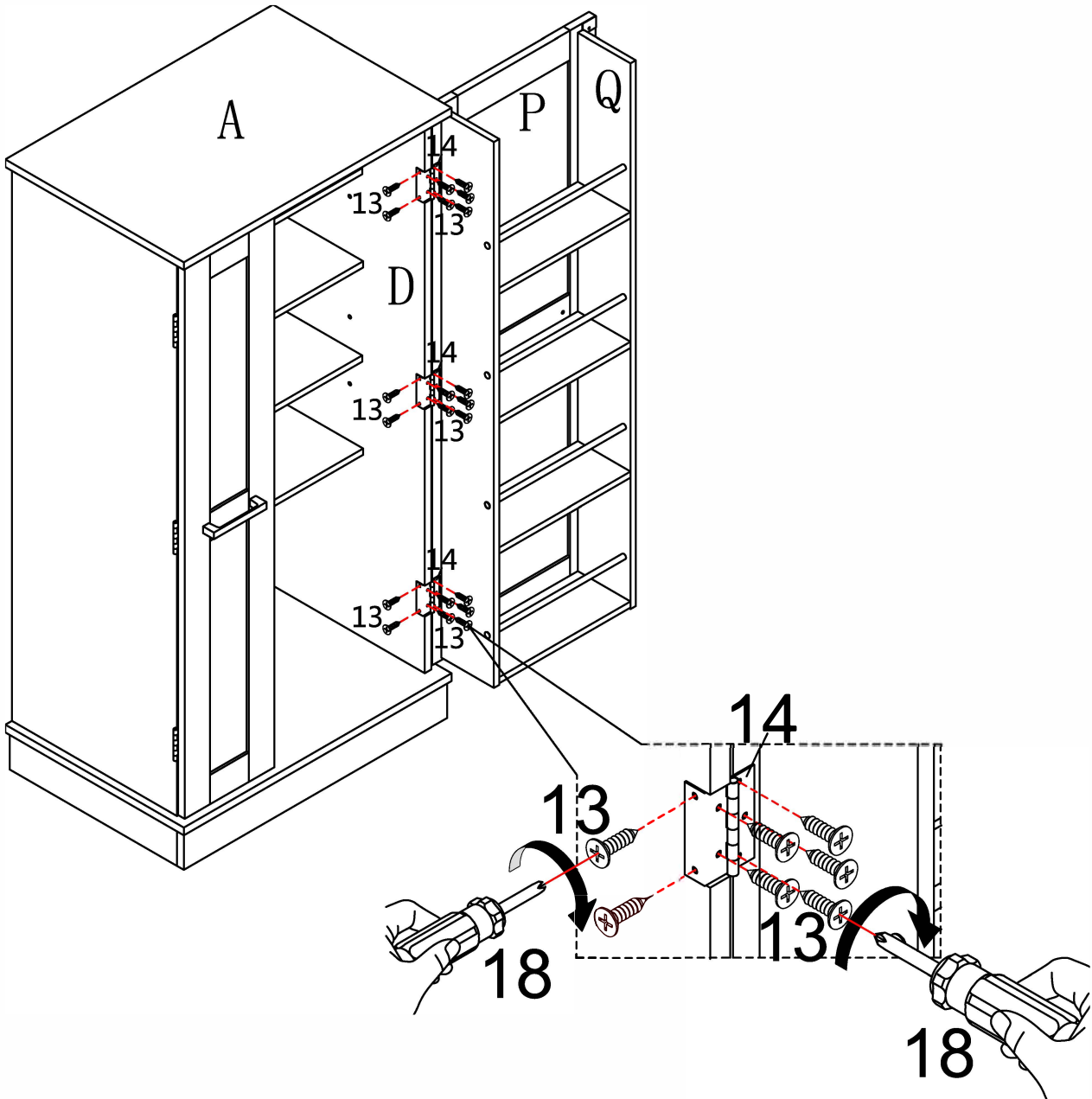

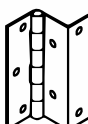
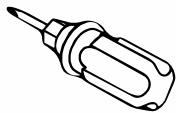
#13	x21	#14	x3	#18	x1
					
φ3.5*14mm*7#					

# ASSEMBLY INSTRUCTIONS

## STEP-16

1. Install the anti-collapse device.
2. Make the position on the wall, that corresponds to the location of part (#8) on the Top panel. Drill and insert the expandable screw part (#16) by hammer.
3. Assemble the part (#8) to the wall, Align the hole in the part (#8)

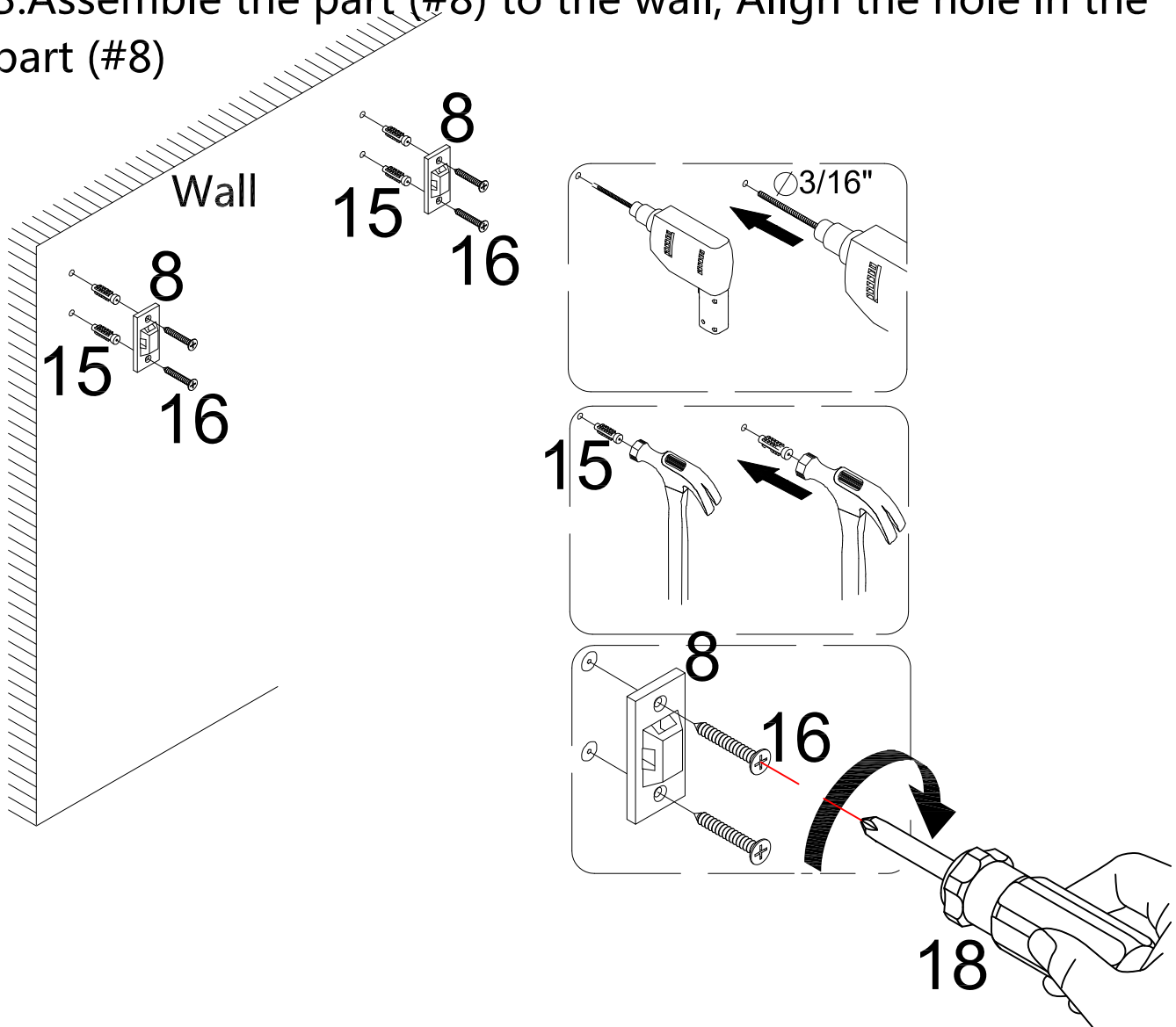

#8	x2

#15	x4

#16	x4
φ3.5*35mm*7#	

#18	x1

# ASSEMBLY INSTRUCTIONS

## STEP-17

1. Let the plastic belt (#17) pass through the both part (#8) and pull tightly.

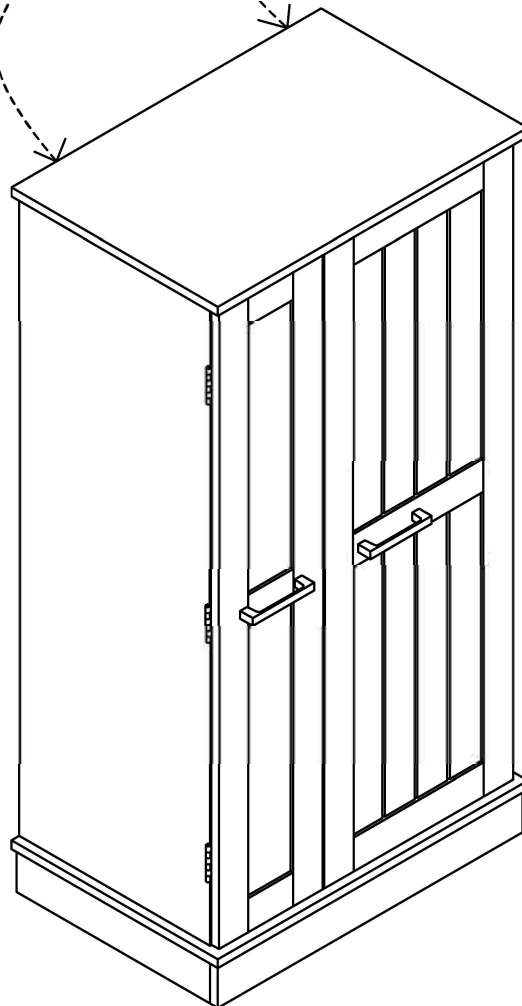
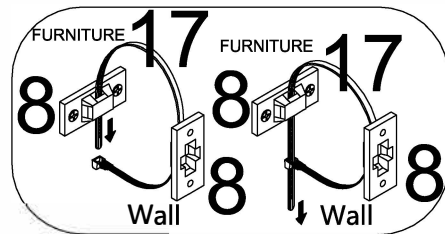

#17	x2

# WARRANTY

1. We strive to offer high-quality products, and we also try our best to satisfy each and every customer that orders from us with product or service as needed.
2. We provide 30 days warranty starting from the time you receive the item. Each customer must provide a record of their order such as the order number, or item receipt for any items that are out of the warranty period you may also still receive.
3. Replacement parts by purchasing them with our company if they are available.

Are you having difficulty  
With assembly? Missing parts?  
Please send email with your order No to  
**[hubeihongmao@163.com](mailto:hubeihongmao@163.com)**  
For return, please check the return policy with  
the retailer or market place you bought from.

Appreciate your purchasing from us.  
Pop up your life by our furniture piece!