

Installation & Assembly

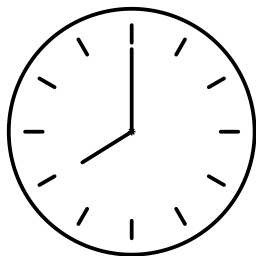
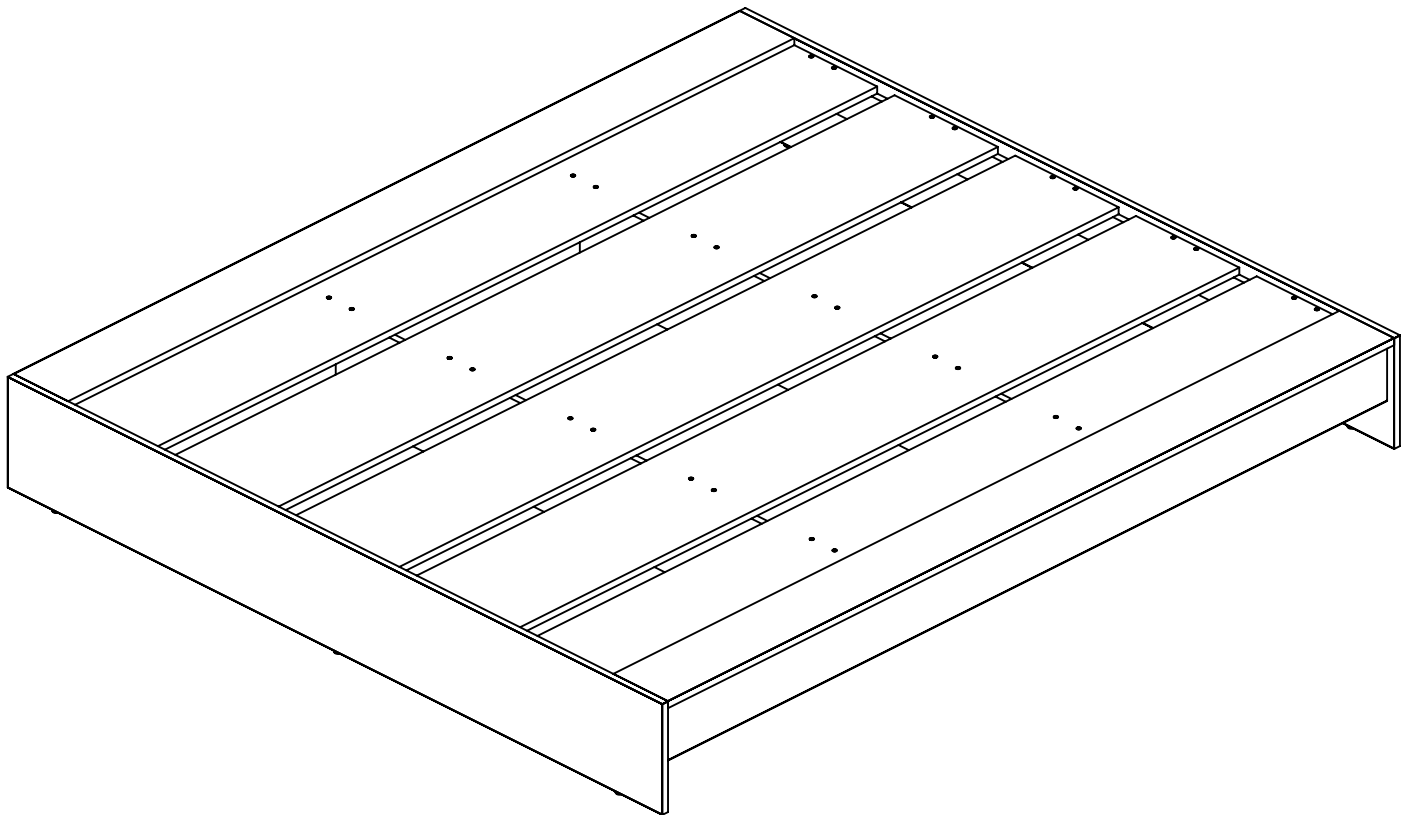

Temps d'assemblage
45 - 60 minutes
Assembly time

IMPORTANT AVANT DE DÉBUTER L'ASSEMBLAGE IMPORTANT BEFORE STARTING THE ASSEMBLY

FRANÇAIS

- Veuillez lire les instructions complètes de ce guide avant de débiter l'assemblage.
- Identifier les pièces (chaque pièce est numérotée); référez-vous à la vue d'ensemble.
- Étalez les pièces afin qu'elles soient facile d'accès.
- Inspectez chaque pièce pour s'assurer que les trous sont libres de poussière.
- Vérifiez que toute la quincaillerie est présente. Utilisez des contenants pour ne pas la perdre.
- Assurez-vous d'avoir tous les outils nécessaires pour l'assemblage.
- Faire l'assemblage le plus près possible de l'endroit où vous souhaitez placer votre meuble, ainsi que dans la bonne orientation.

ENGLISH

- Please read the complete instructions in this guide before beginning assembly.
- Identify the parts (each part is numbered); refer to the overview.
- Spread out the pieces so that they are easy to access.
- Inspect each part to ensure that the holes are free of dust.
- Verify that all hardware is present. Use containers so you do not lose it.
- Make sure you have all the necessary tools for assembly.
- Assemble as close as possible to where you want to place your furniture, as well as in the correct orientation.

Quincaillerie 1:1 Hardware 1:1

A  48x

B  32x

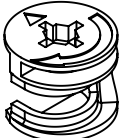
C  14x

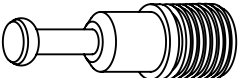
D  14x

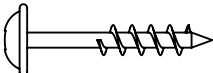
E  4x

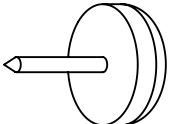
F  10x

Outillage requis Required tools

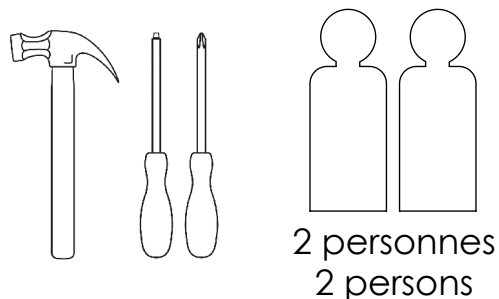

⚠ À retenir durant l'assemblage / Things to remember during assembly ⚠

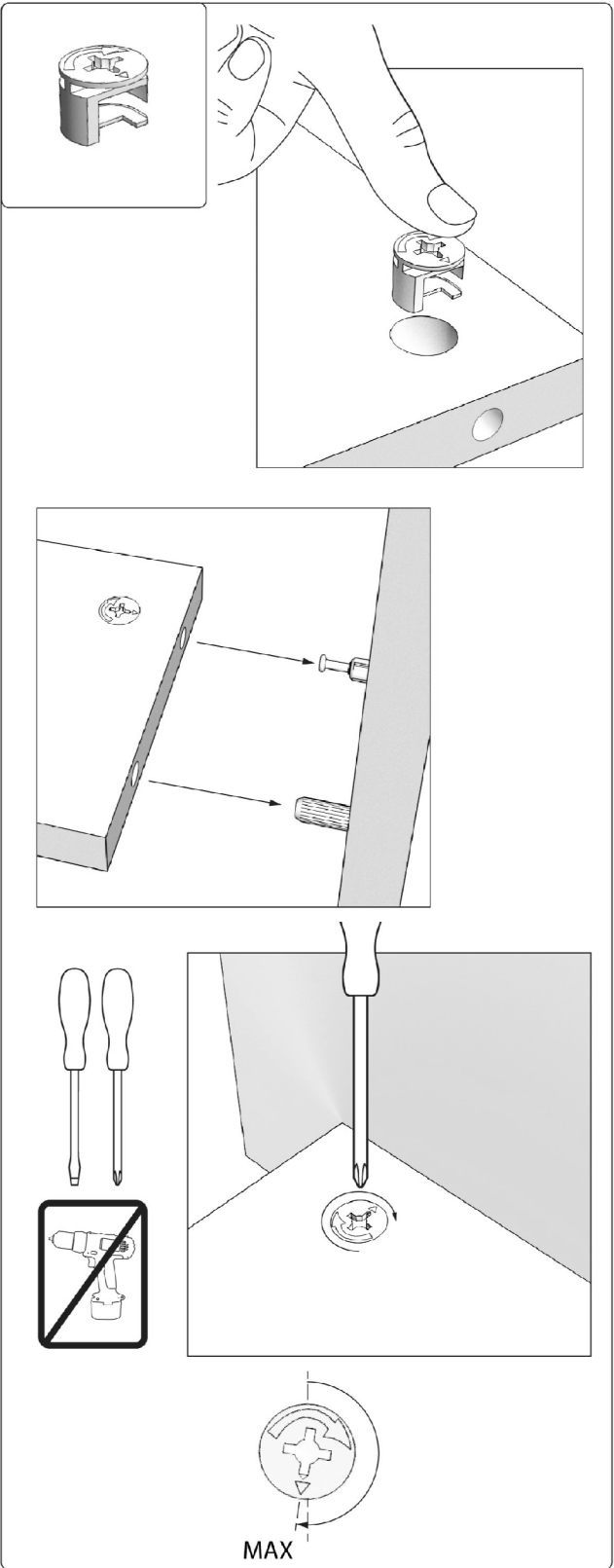
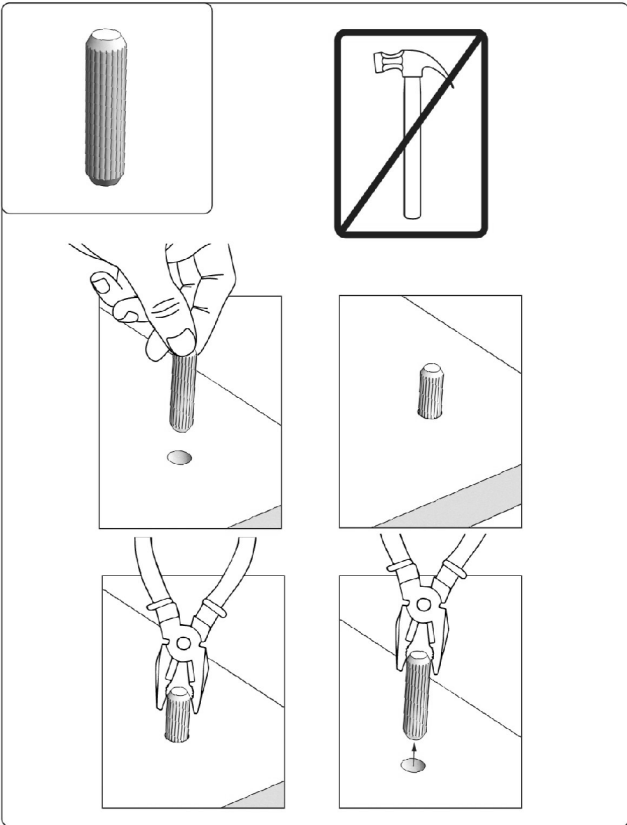
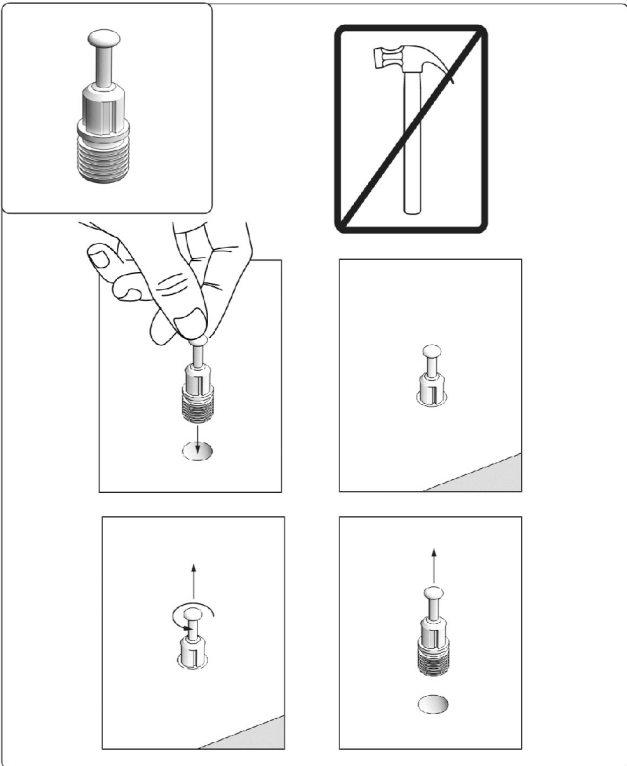

VUE D'ENSEMBLE OVERVIEW

Conservez cette page pour référence des numéros de pièce
Keep this page as a reference for part numbers

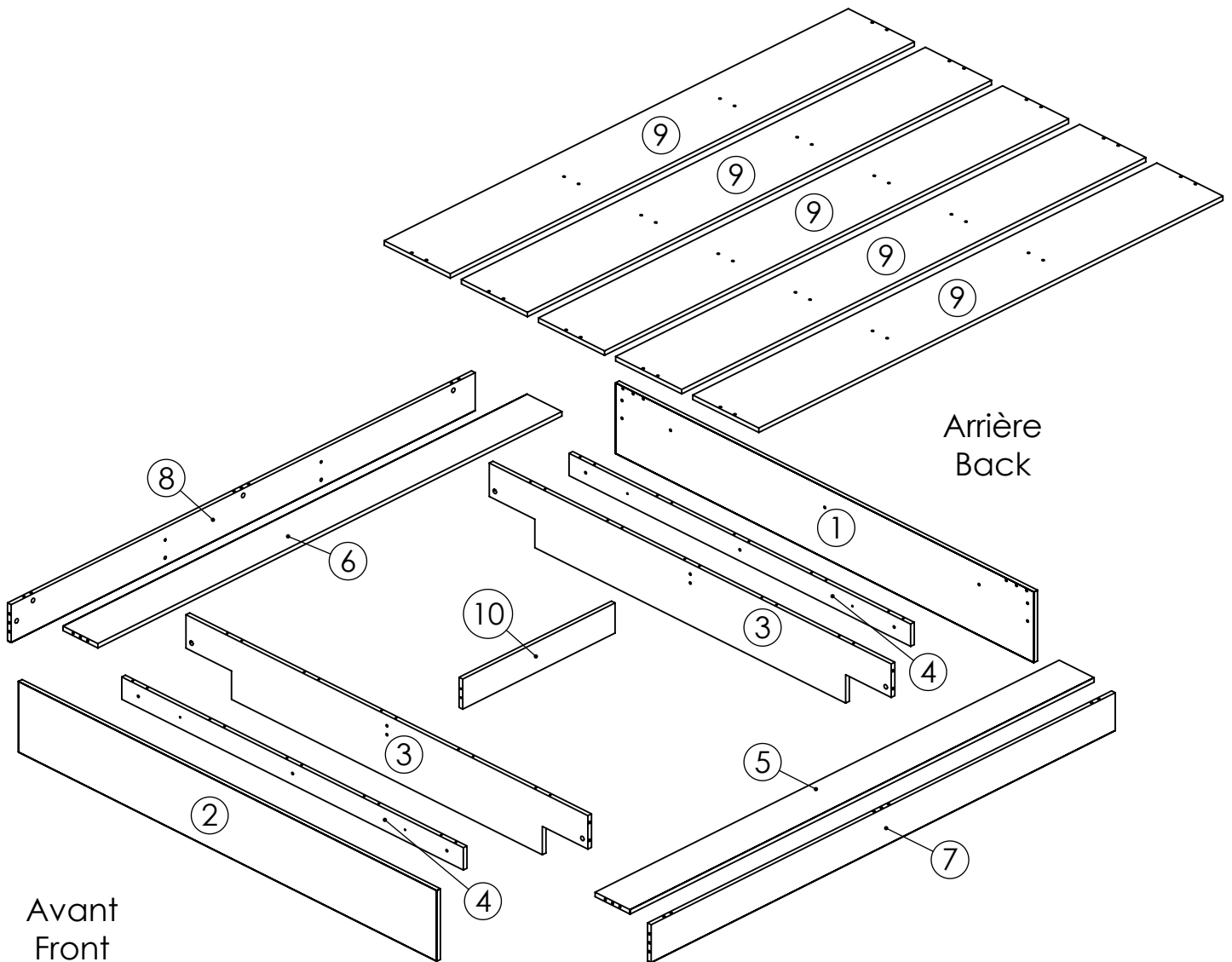

#1

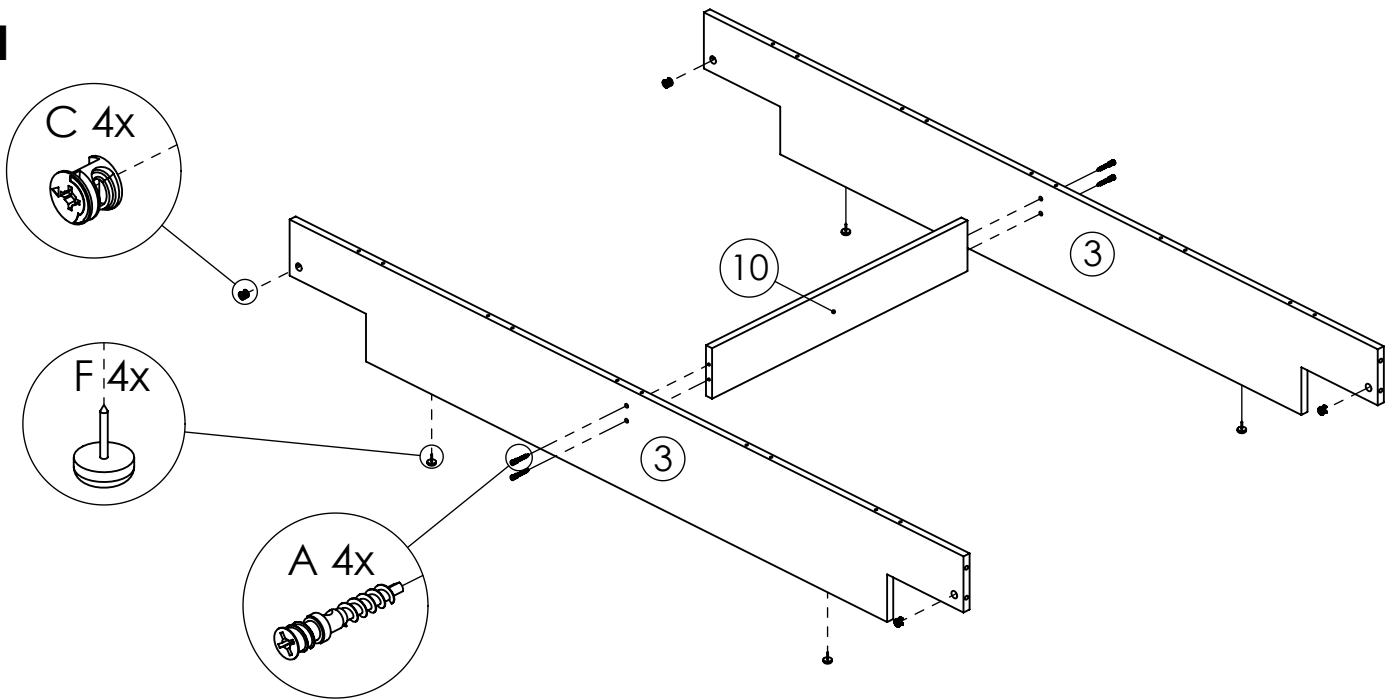

#2

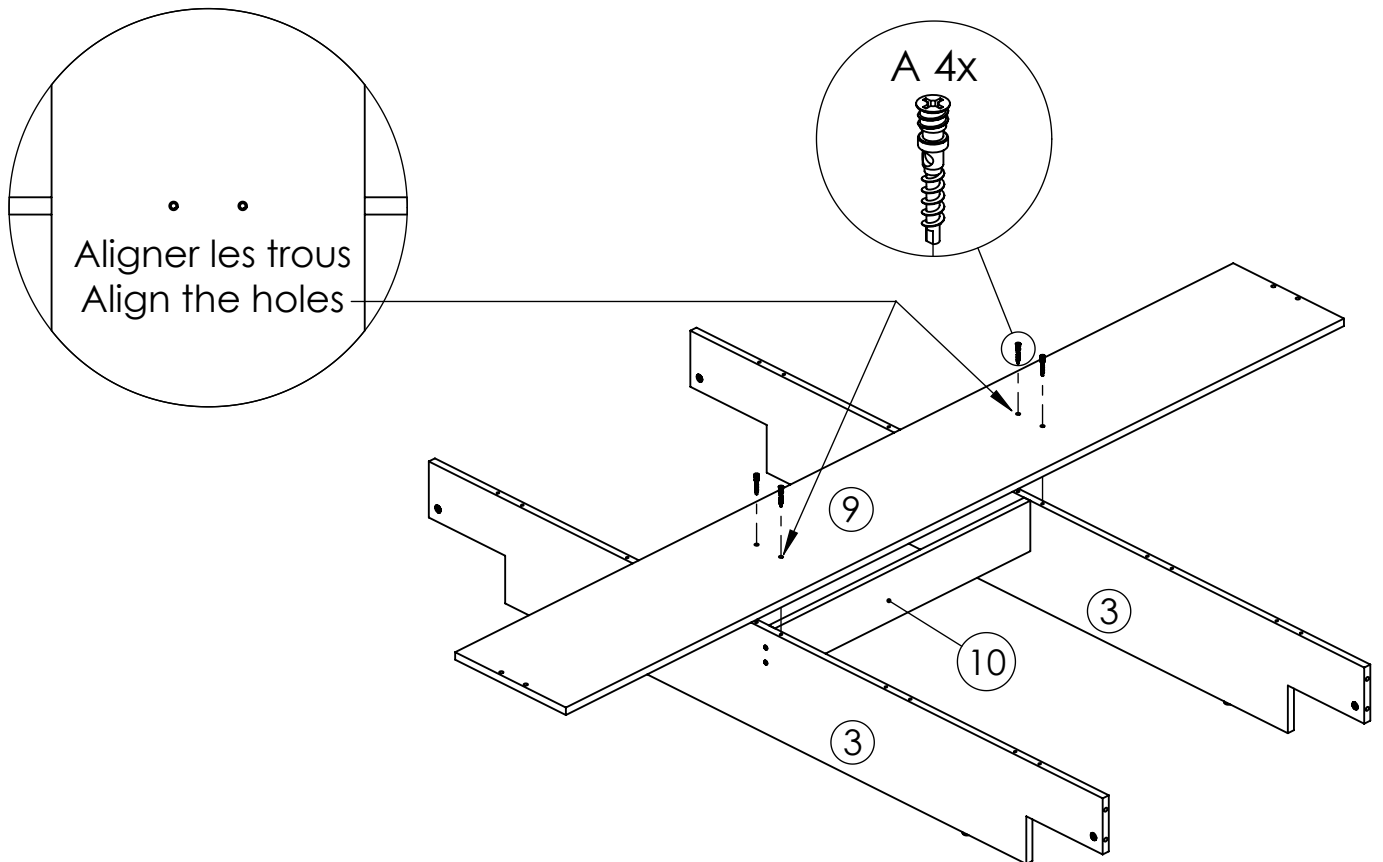

#3

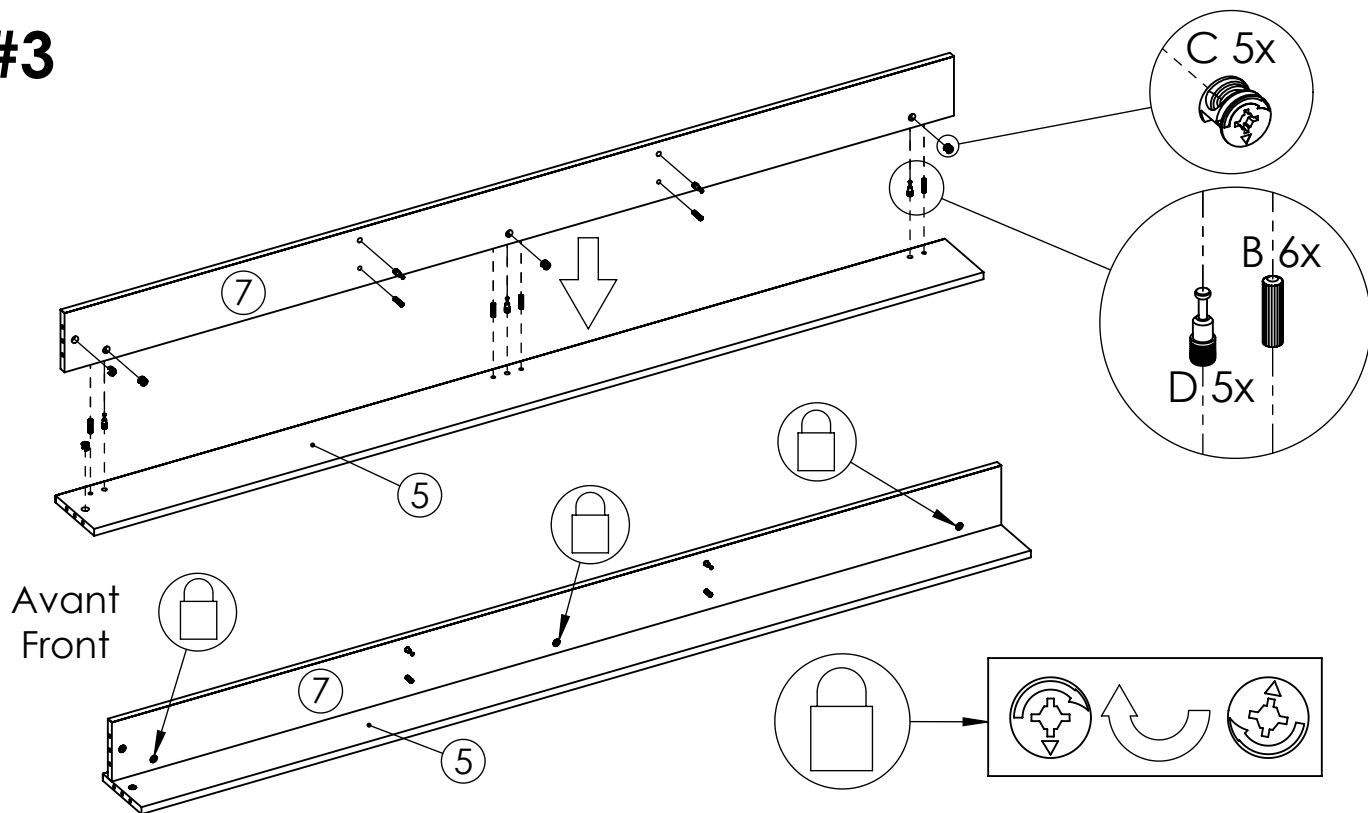

#4

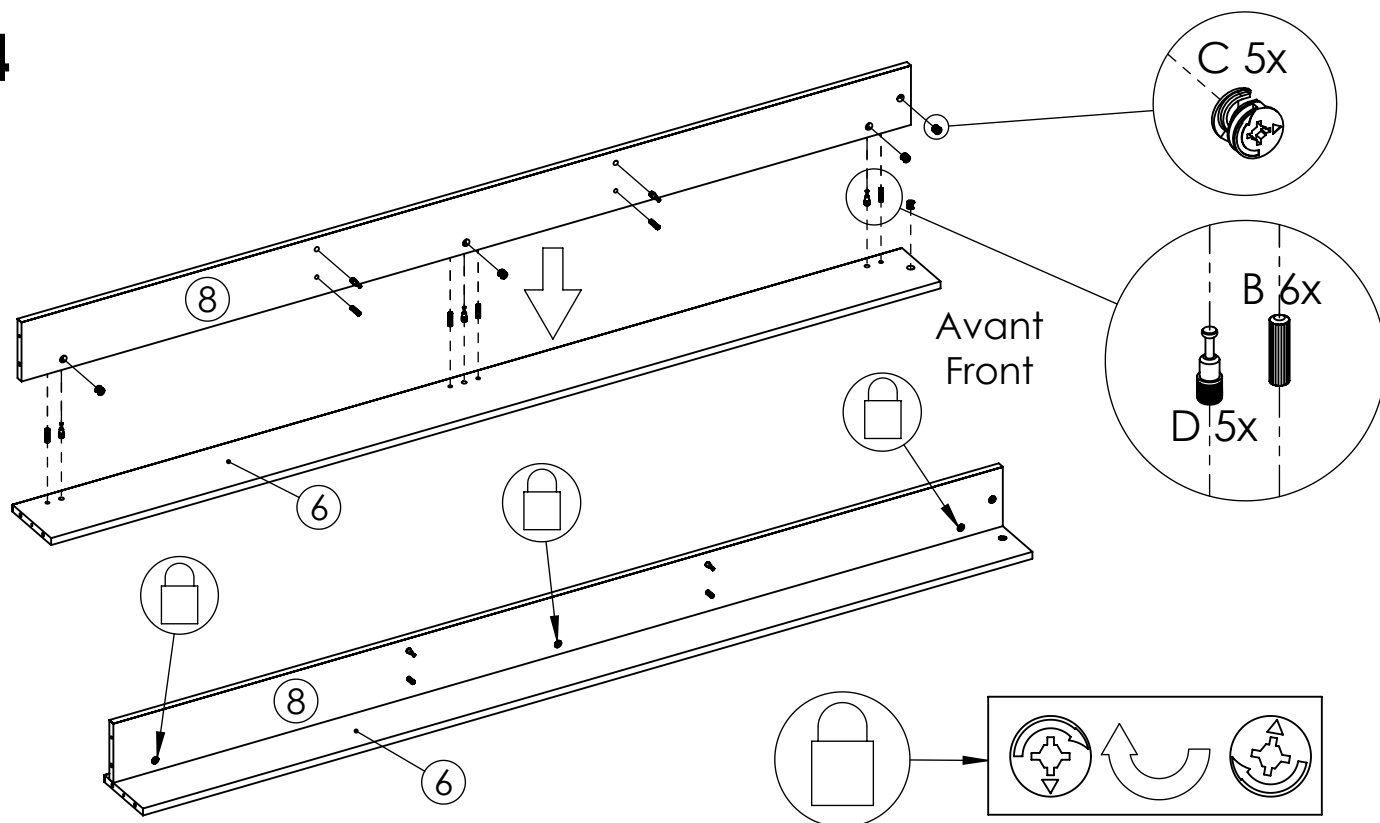

#5

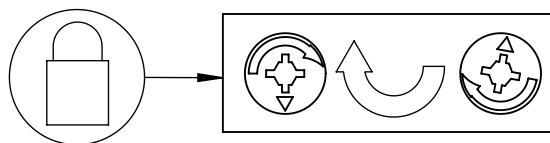
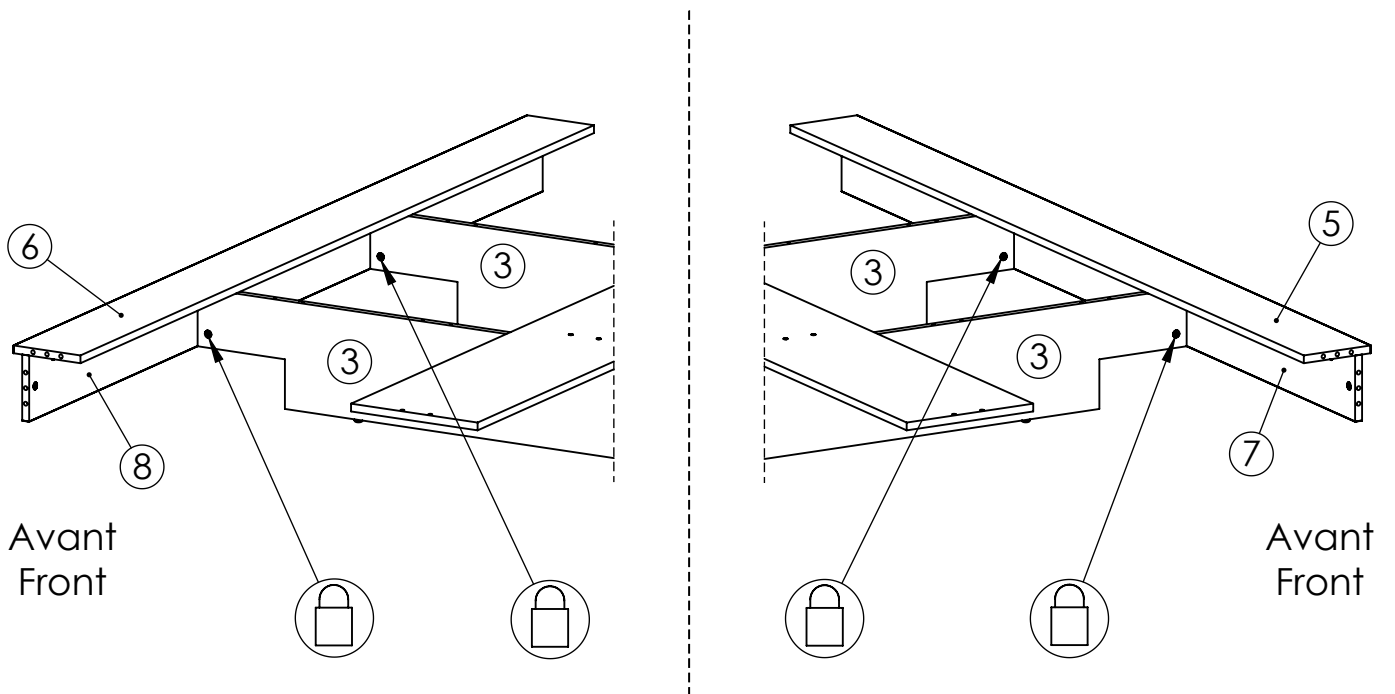
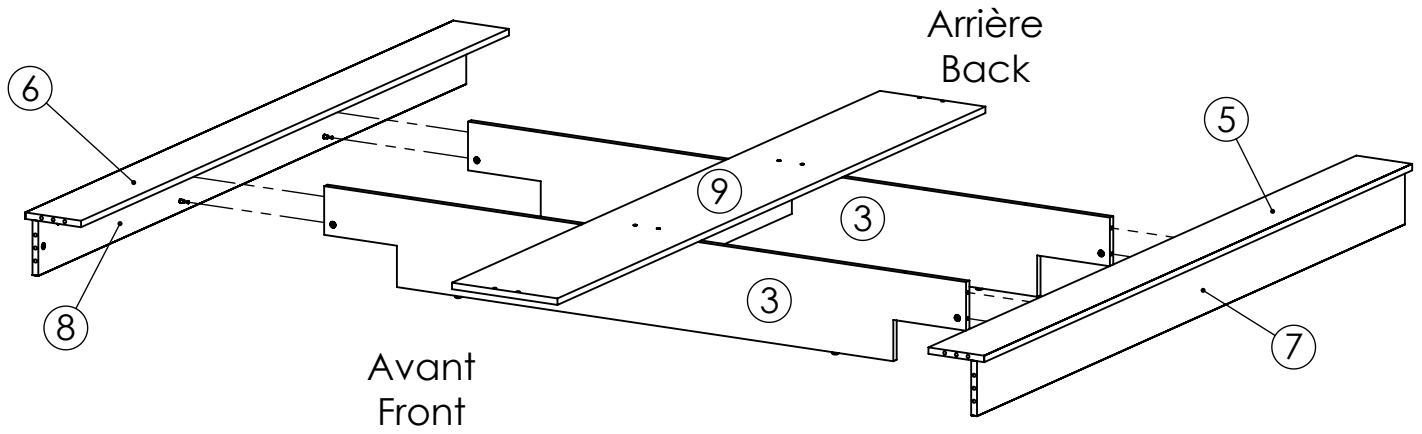

#6

Trous vers le haut
Holes facing up

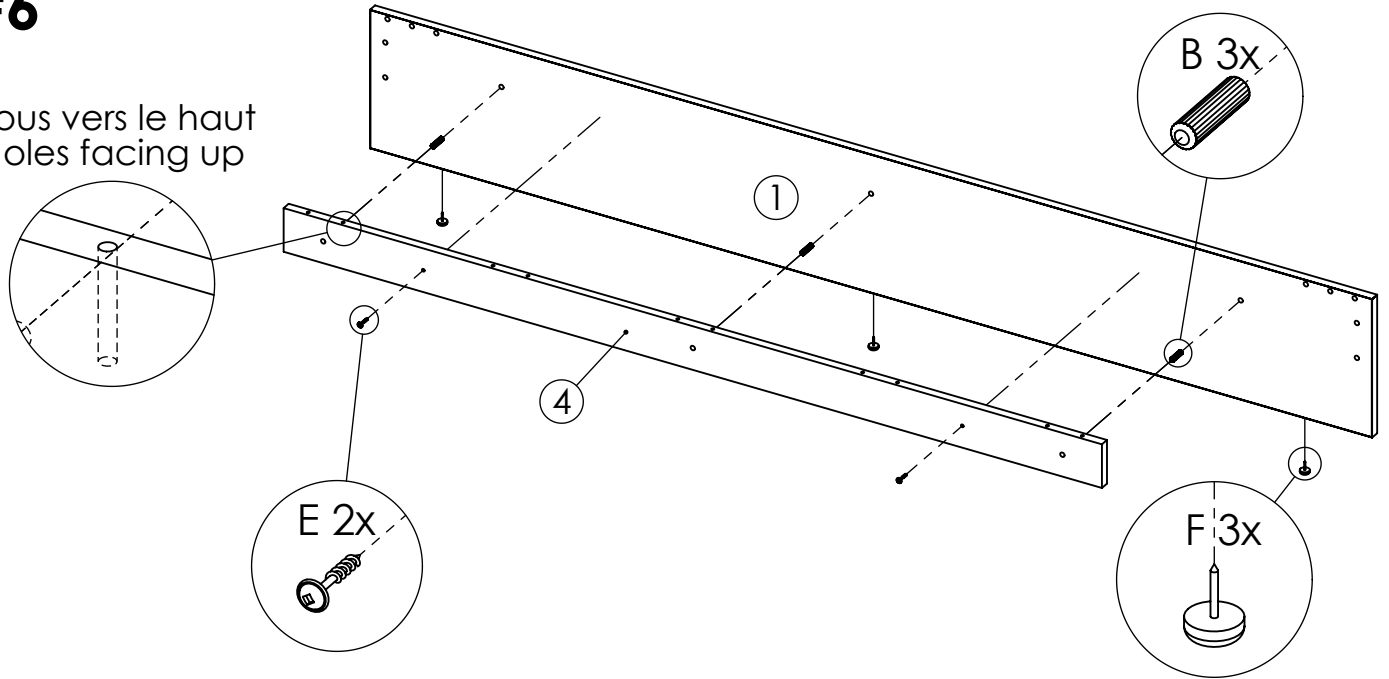

#7

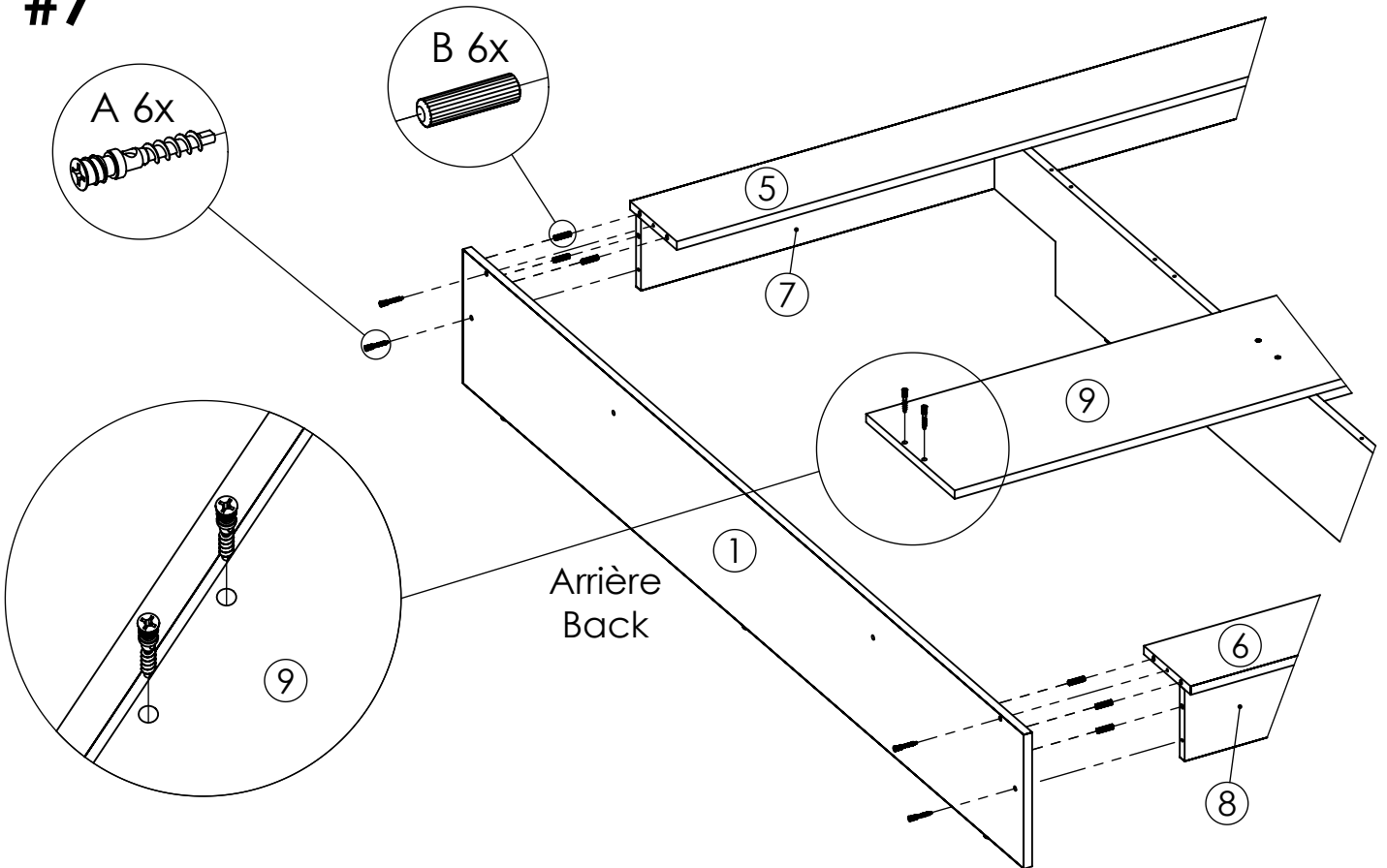

#8

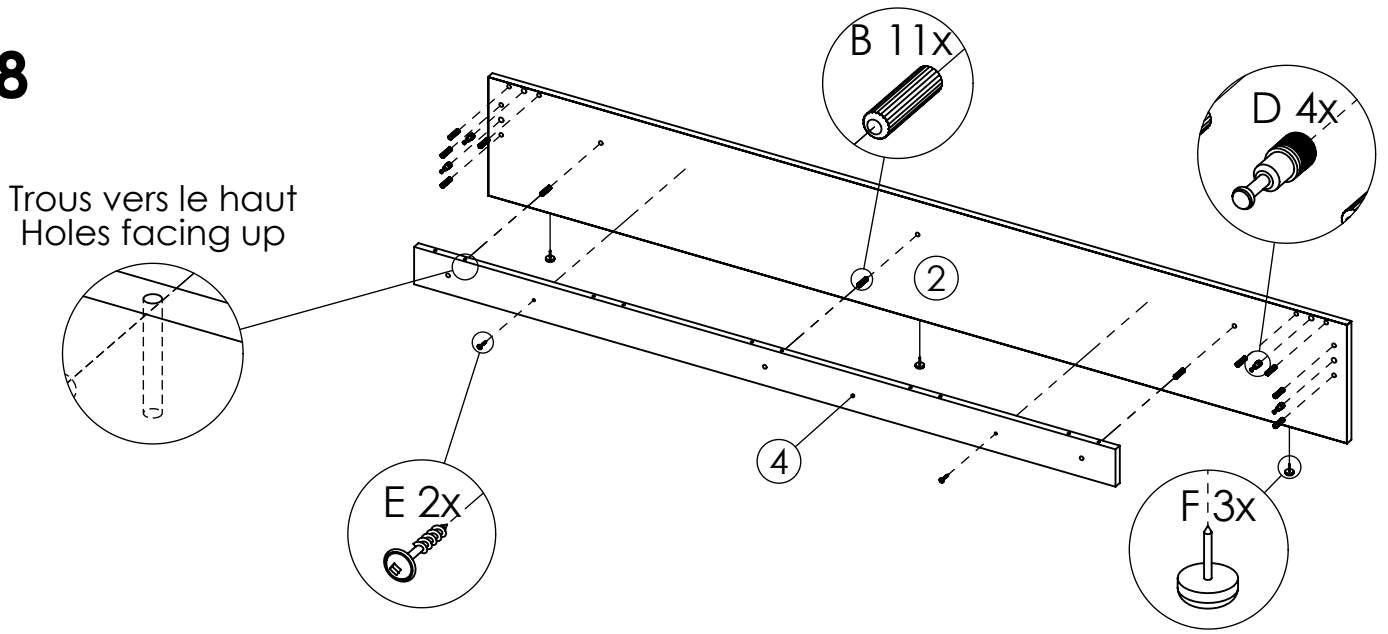

#9

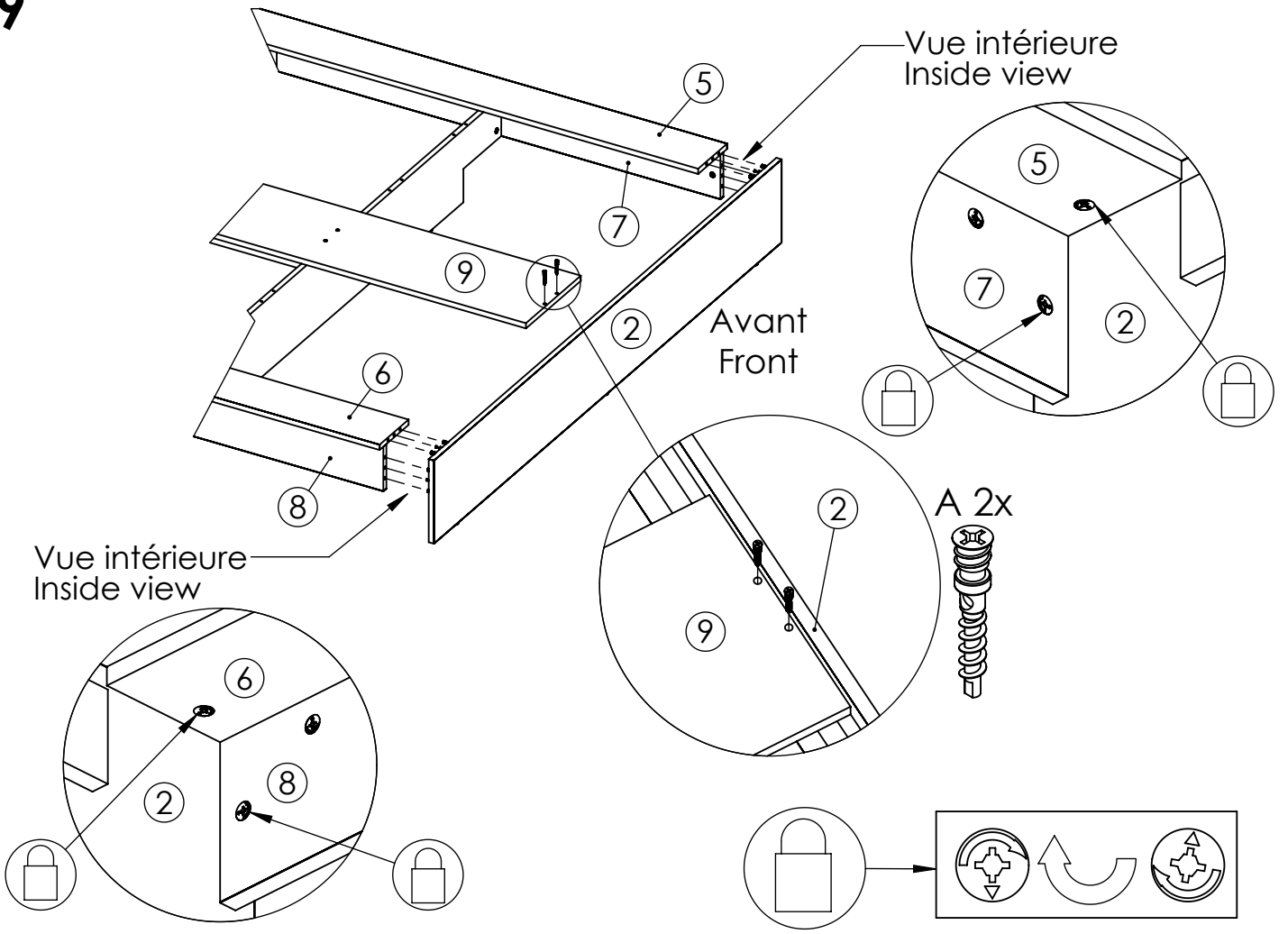

#10

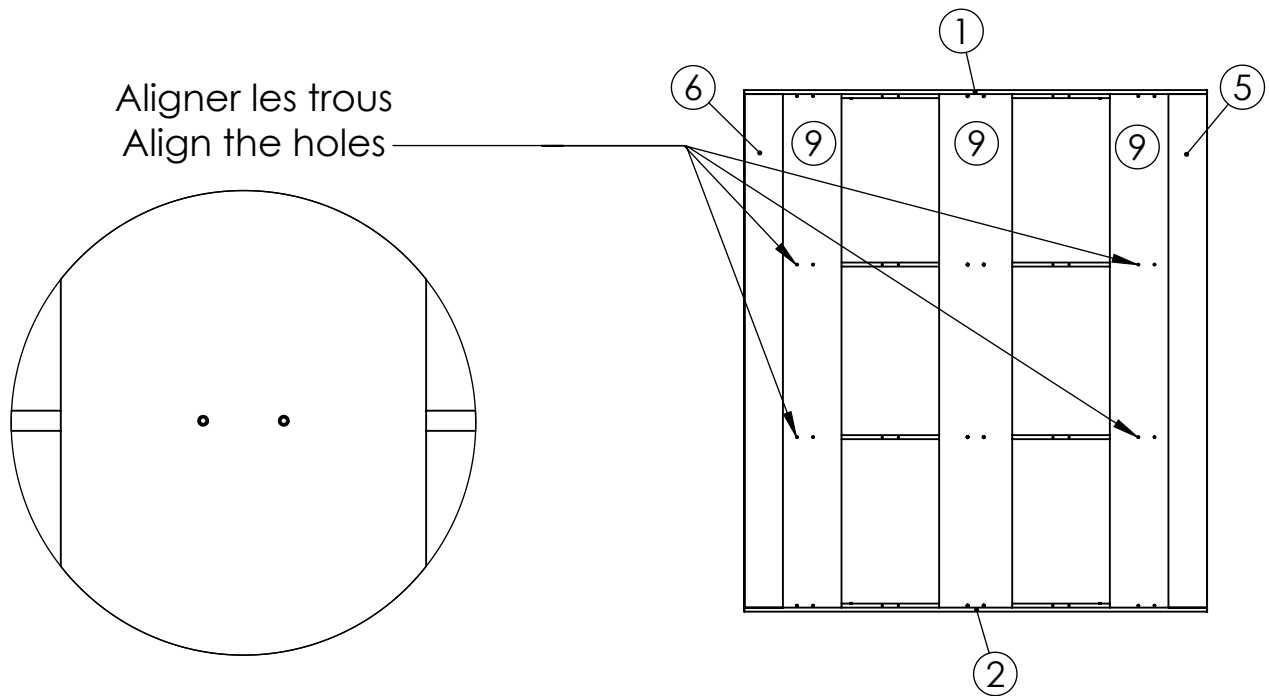
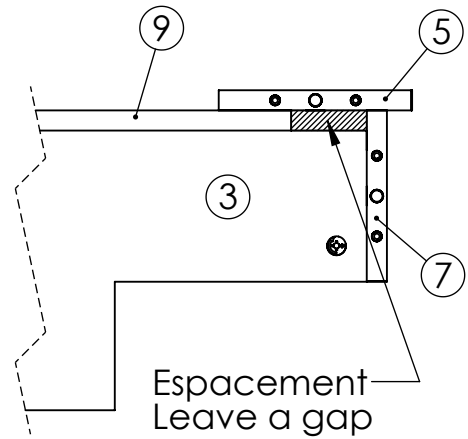
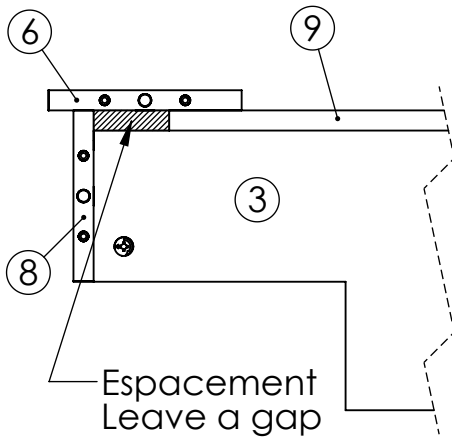
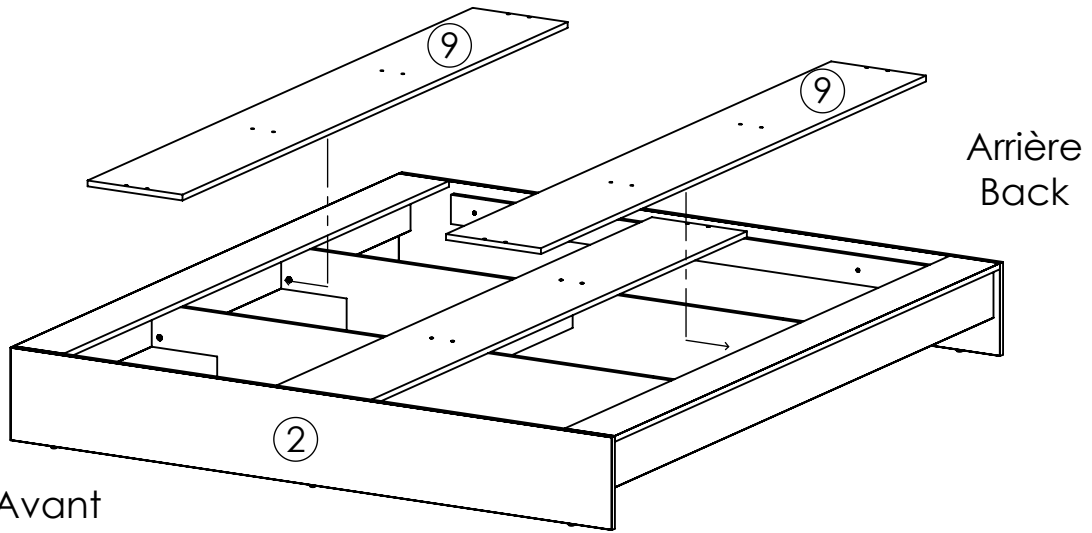

#11

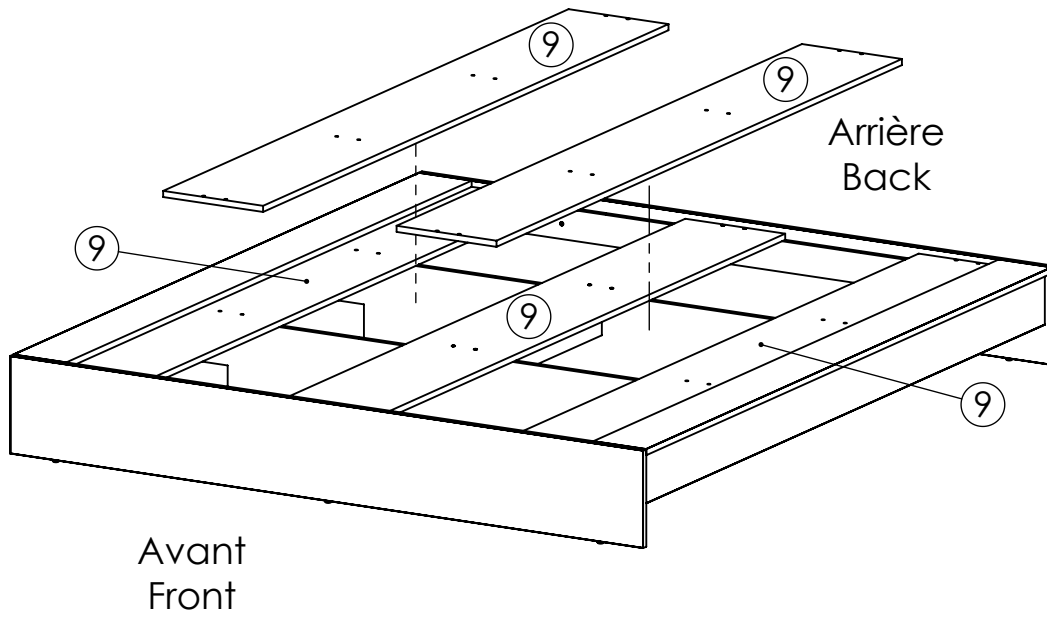

Centrer les trous
Center the holes

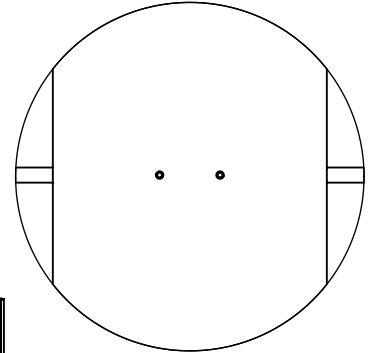

#12

