

CARE AND MAINTENANCE

Always use felt pads under all articles to prevent discoloration or softening of the lacquer. Plastic and rubber bases on items can discolor wood. Wipe up spills immediately and avoid common hazards such as hot dishes, harsh solvents and abrasives. Cleaning should be done with a soft lint free cotton cloth dampened with water or furniture polish. On highly used surfaces we recommend applying a quality paste wax which should be used on a regular basis to provide additional protection from scratches and spills. How often you apply the wax depends on how much wear the furniture receives.







NOTICE

* Please make sure that you have all parts indicated before you begin assembly of this item

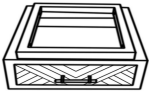
* This item should be assembled on a soft surface to prevent scratching the finish during assembly

* This item may require periodic tightening

Part List

PIECE	DESCRIPTION	PICTURE	QUANTITY
A	Table Top		1X
B	Side Panel		2X
C	Connecting Timber		2X
HW1	Allen Key		2X
HW2	Allen bot 8x1.41x40mm		4X
HW3	Allen bot 6.14x1.41x20mm		4X

Product Dimensions: 19"W x 15.75"D x 26"H

Weight Capacity: 40LBS

