

STEP 3

Attach Shelf Panel (A) & Long Pole (1) to the assembled unit, as shown.

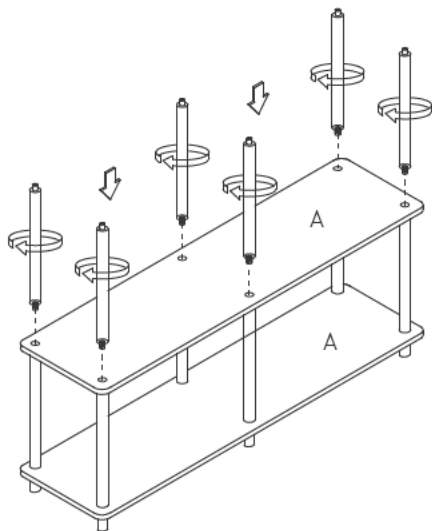

STEP 4

Attach another Shelf Panel (A) and tighten with Top Cap (3), as shown.

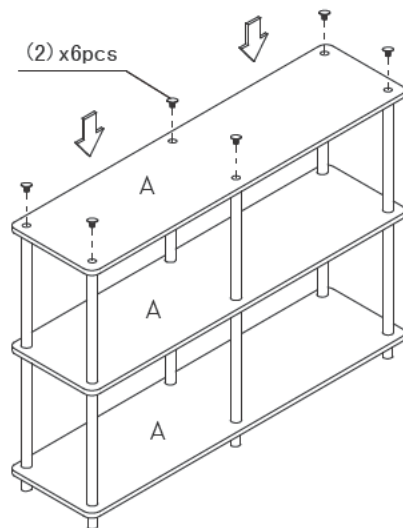

Recommended Maximum Weight

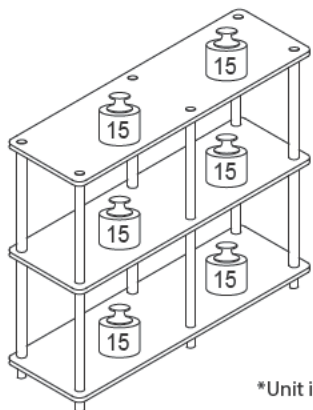

*Unit in Pound(lbs)

WARNING:

>This unit has been designed to support the maximum loads shown. Exceeding these load limits could cause sagging, instability, product collapse, and/or serious injury.

>DO NOT allow children to climb on unit.

>Put heavier items on lower shelves.

Assembly Instruction

00:20

Approx. 20 minutes





Recomm. 1 Person

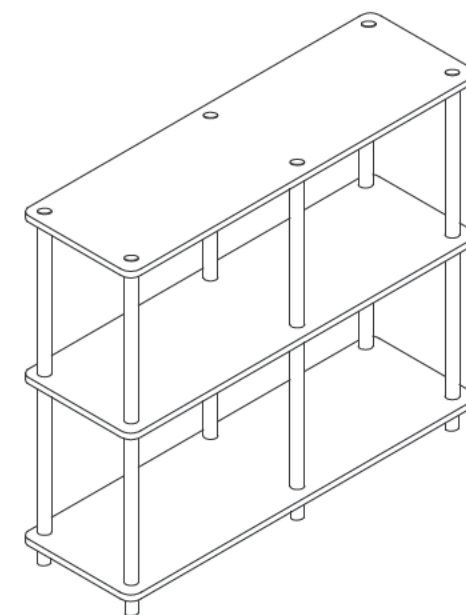

No Tools Required

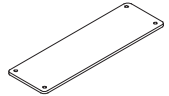

No	Hardware List	Qty
1	Long Pole 	12pcs
2	Round Leg 	6pcs
3	Top Cap 	6pcs

No	Parts List	Qty
A	Shelf Panel 	3pcs

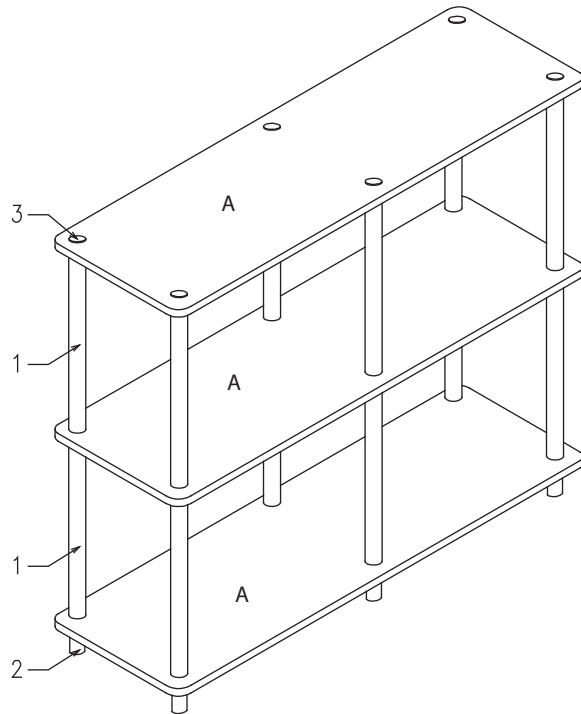

USEFUL HINTS BEFORE YOU START:

1. Read each step carefully before starting.
2. It is important that each step is performed in correct order to avoid difficulties.
3. Identify, sort and count the parts before assembly.
4. Assemble your furniture on packaging cardboard to prevent scratch or damage.
5. Clean the product with mild cleanser using soft damped cloth. Do not use harsh or abrasive cleanser.
6. Using incompatible hardware might cause damage to product.

STEP 1

Attach Round Leg (2) to the bottom of Shelf Panel (A), as shown.

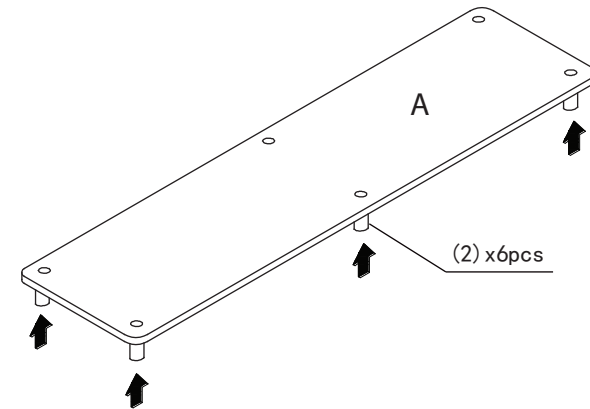

STEP 2

Attach Long Pole (1) on Shelf Panel (A) and tighten it.

