

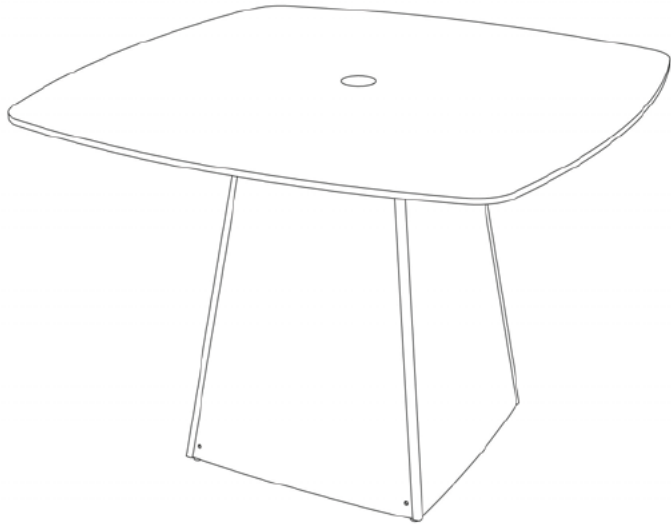













Sintered Stone Table

ASSEMBLY INSTRUCTIONS

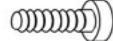

BEFORE ASSEMBLY:

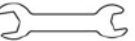
- Please read these instructions carefully before starting assembly. We suggest you carry out the assembly on a soft surface like a carpet, so as to avoid scratching the paint. Keep children away during assembly. This item contains small parts which can be swallowed by children.
- This product was made for the explicit purpose of providing outdoor function and is not to be used as a toy. This product is for residential use only. This product is NOT intended for commercial use; unintended use will void the warranty.
- This product is not intended for use during inclement or severe weather, that includes but is not limited to rain, hail, sleet, snow, wind, freezing conditions and extreme heat.
- Please note because of the nature of cast metal, you may find roughness on the surface which enhances the beauty of the product and is not a defect.
- Aluminum is soft metal, please do not use power tools, and over tighten may strip threads or break the parts.
- When not in use, store and/or cover the product in a cool dry location. Do not locate the product near any sort of high heat. Do not use the product as a support.
- Children under the age of 10, who are near the product, should be supervised by a competent adult at all times.
- Do not discard any of packaging until you finish the assembly. Keep the assembly instructions for future reference or warranty.

AX2  Base Panel-1	BX2  Base Panel-2	CX1  Table Top	DX8  Nut(M6)
EX8  Spring Washer(M6)	FX8  Washer(M6)	GX8  Bolt(M6*15)	HX4  Washer(M8)
IX4  Spring Washer(M8)	JX4  Bolt(M8*20)	KX1  Umbrella Hole Cover	LX1  Wrench
MX1  Allen Wrench			

1

Step 1: Place all the parts on a clean and soft surface. Identify all the parts and hardware kits against parts list. Then place **Base Panel-1(A)** on a flat surface and subsequently insert **Base Panel-2(B)** into **Base Panel-1(A)** along the slots as **Fig(1)**.

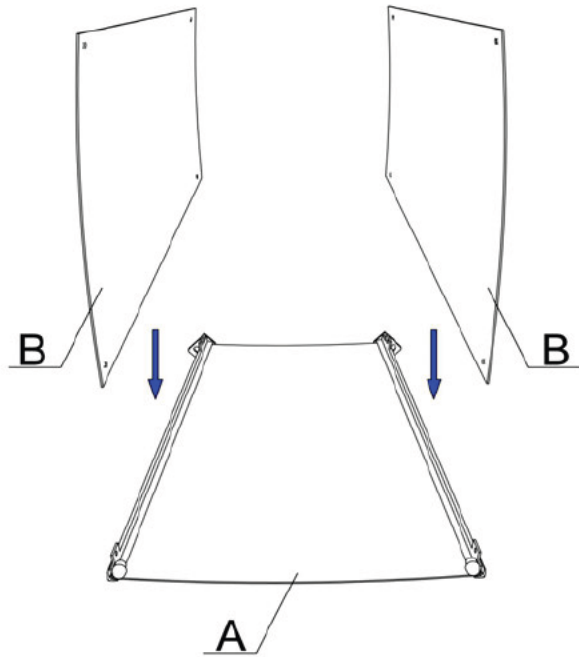

(1)

Tips: Being careful not to tighten all the bolts and nuts completely so that you can make final adjustments to the overall table structure.

2

Step 2: Then assemble **Base Panel-1(A)** and **Base Panel-2(B)** with parts **(D,E,F,G)** in the order displayed in **Fig(2)**. For installation, use **Wrench(L)** to hold the **Nut(D)**, then tighten the **Bolt(G)** with **Allen Wrench(M)**

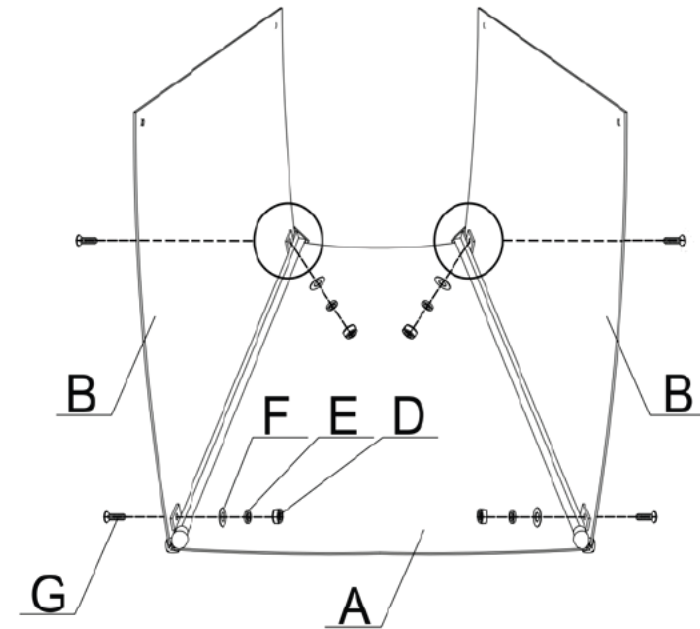

(2)

3

Step 3: Then assemble another **Base Panel-1(A)** and **Base Panel-2 (B)** with **Parts(D,E,F,G)** in the order displayed in Fig(3)

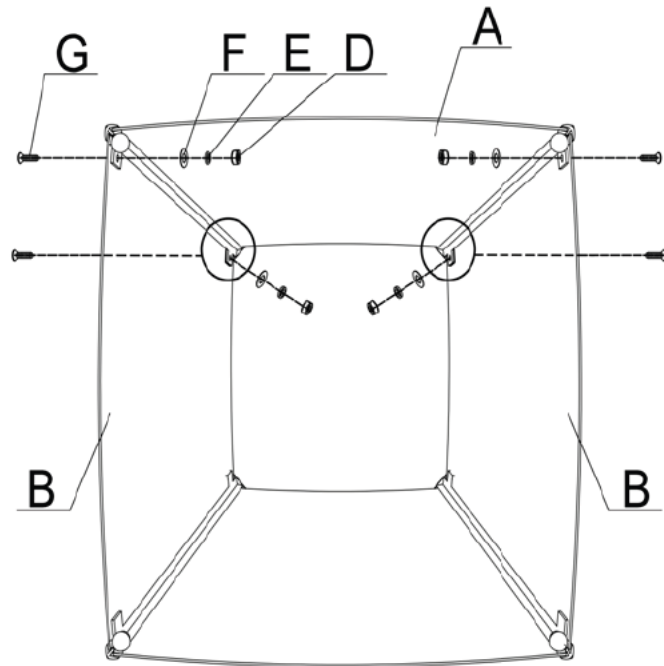

(3)

4

Step 4: Turn over the **Table Top(C)**. Assemble the **Base** and **Table Top(C)** using **Parts(J,I,H)** with **Allen Wrench(M)** as shown in Fig(4).

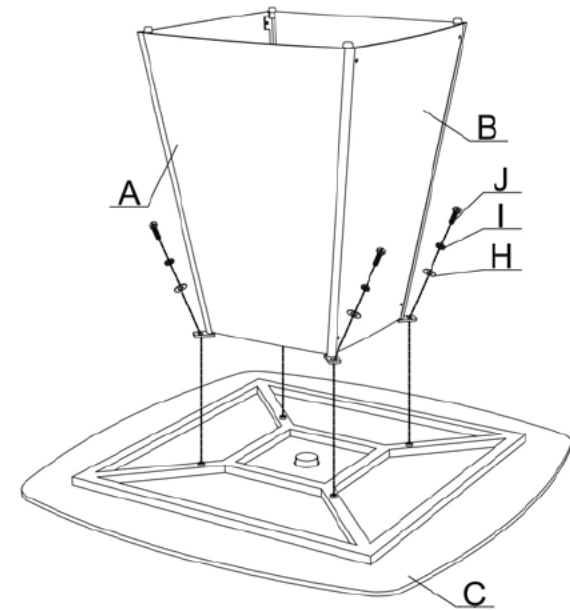

(4)

5

Step 5: Turn over again and check that all the parts are securely connected, tighten all bolts and nuts fully. Adjust the levelers till the table is stable. And cover the **Umbrella Hole Cover (K)**. Now Your table is ready to use.



Tips: Tighten all the bolts and nuts with Allen Wrench(M) and Wrench(L).

Use a weighted umbrella base for stability. Close Umbrella during strong winds to prevent tipping.