

INSTURCTION MANUAL

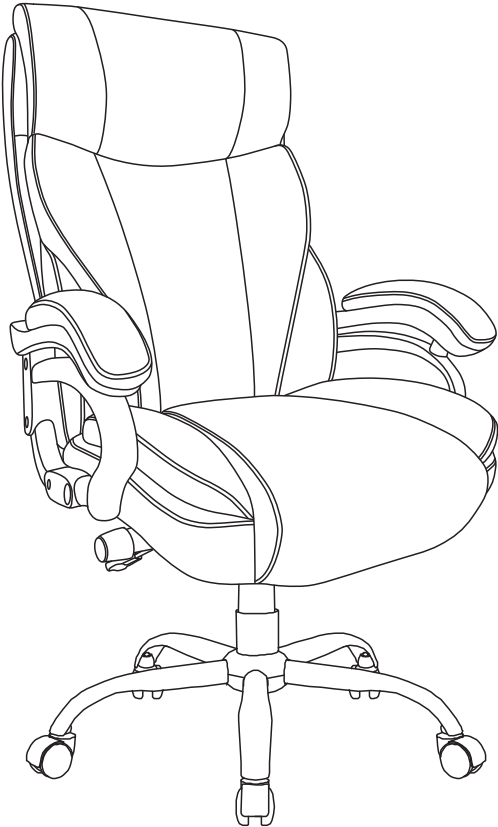

ASSEMBLY GUIDE

Before enjoy the comfort chair, you have to put it together. This Assembly Guide will take you through the basic assembly process. To make sure your assembly goes smoothly, please follow the assembly instructions, **and especially the important safety information.**

Also, while it is possible to assemble the chair on your own, **having a second person to help you makes it even easier.**

Before you begin, please check if there are any missing parts from the package. Should there be any issues, please don't hesitate to drop us an email and we'll help you out ASAP.

If you run into any difficulty during the assembly, remember to check out the Assembly Video to see if you've missed anything. If you're unable to resolve your problems, drop us an email as well and our support team will assist you.

PACKAGE LIST

(A)



Casters

Quantity: 5

(B)

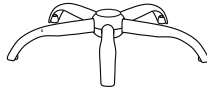

Star Base

Quantity: 1

(C)



Gas Lift

Quantity: 1

(D)

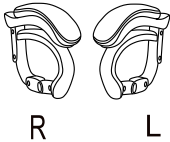

Arms

Quantity: 2

(E)

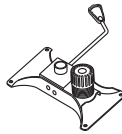

Seat Plate

Quantity: 1

(F)

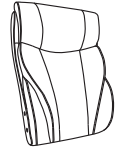

Back Cushion

Quantity: 1

(G)



Seat Cushion

Quantity: 1

(H)

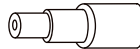

Plastic cover

Quantity: 1

(1)



Spacer Bolts M6*30mm

Quantity: 6

(2)

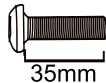

Bolts M6*35mm

Quantity: 8

(3)



Quantity: 4

(4)



Wrench M6

Quantity: 1

(5)



Plastic Caps

Quantity: 8

ASSEMBLY INSTRUCTION

If possible, using drill bit with your electric drill to install our chair will make assembly more convenient.

STEP 1 : Turn the Star Base upside down, then press the Casters into the holes at the end of each base leg.

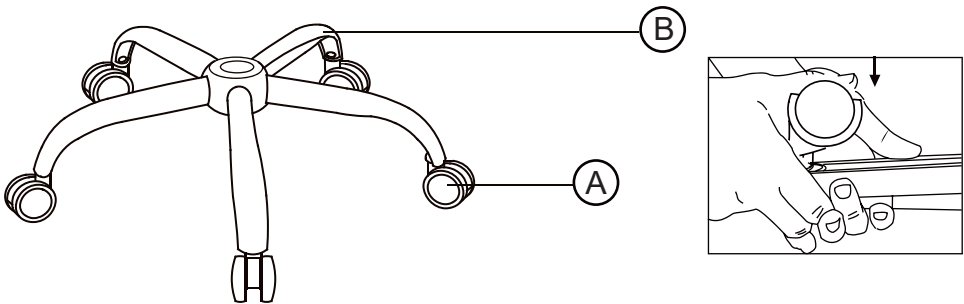

STEP 2 : Turn the Star Base upright and insert the Lift into the center hole of the Star Base, the Lift Cover should be placed over the Lift.

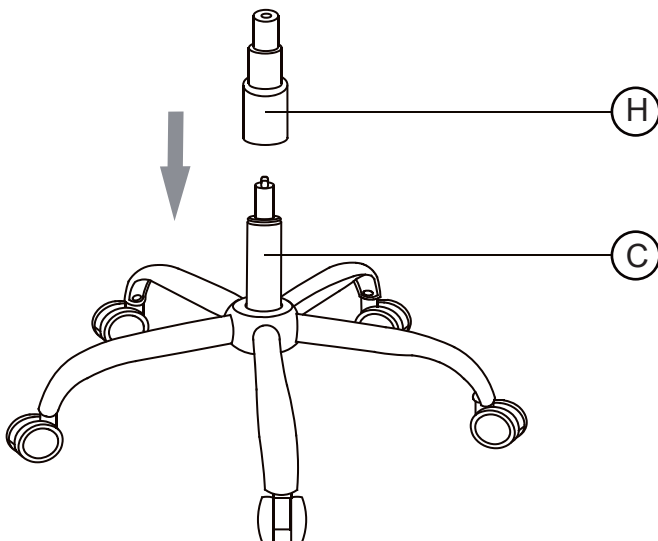

STEP 3 : Align the seat plate to the bottom of the seat cushion, make sure that the front of the seat plate is facing the front of the seat cushion. Attach the seat plate to the seat cushion using four M6X30m bolts, and four spacers, tighten all the bolts with the T-wrench.

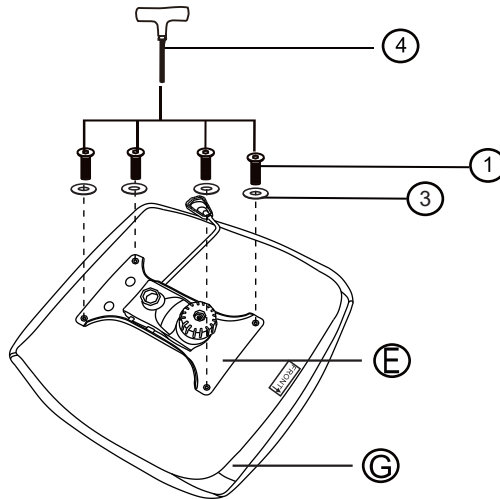

STEP 4 : Turn the seat cushion upright and align the center hole of the seat plate over the lift .then push the seat cushion down onto the lift firmly until the connection is secure.

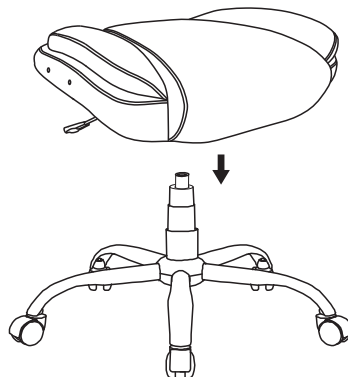

STEP 5 : Attach the arms to the seat cushion with four M6x35mm bolts, using the Wrench.

Note: Arm rests are labeled with an “L”(left)or “R”(right) to show which sides they should be placed on.

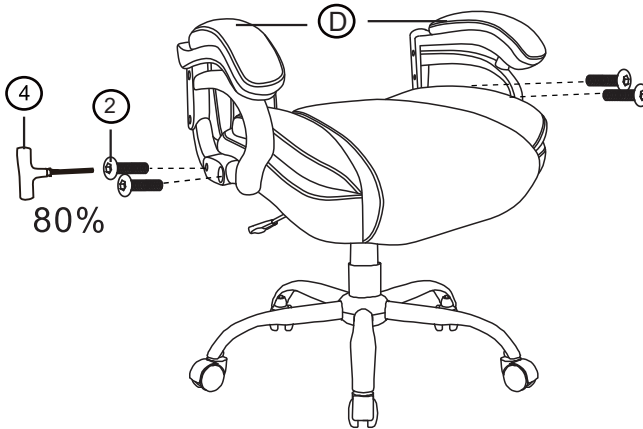

STEP 6 : Attach the back cushion to the arms with four M6x35mm bolts using the T-wrench.

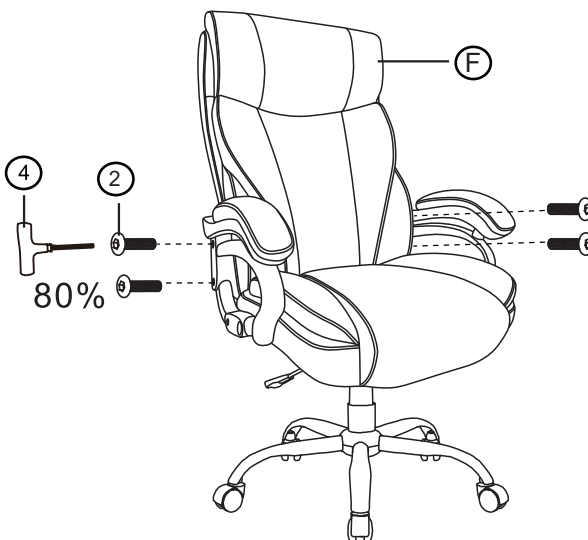

STEP 7 : Align the BACK ADJUSTER to the bottom of seat cushion with two M6*30mm Bolts.

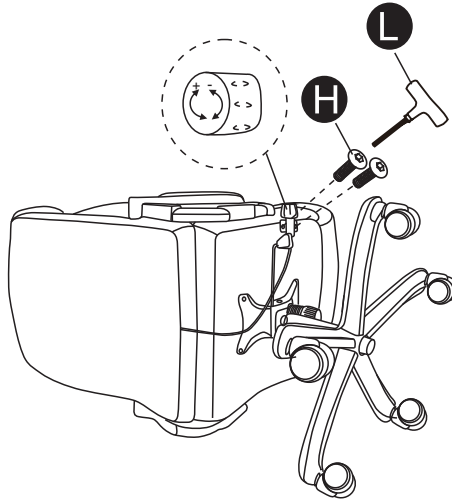

STEP 8 : Adjust the balance first, then fully tighten all the bolts on each side.

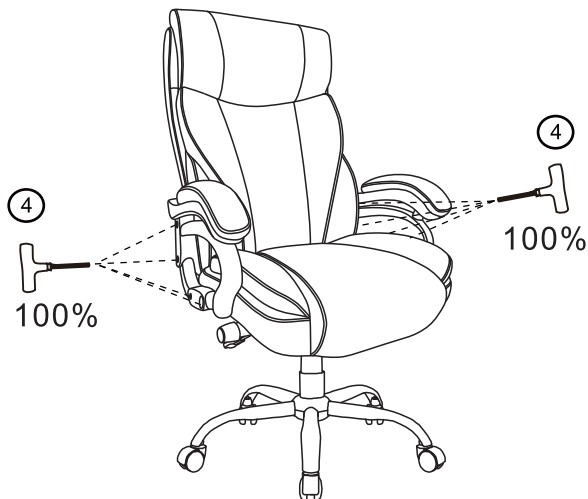

STEP 9 : Press the plastic caps into the armrest holes to cover the bolts.

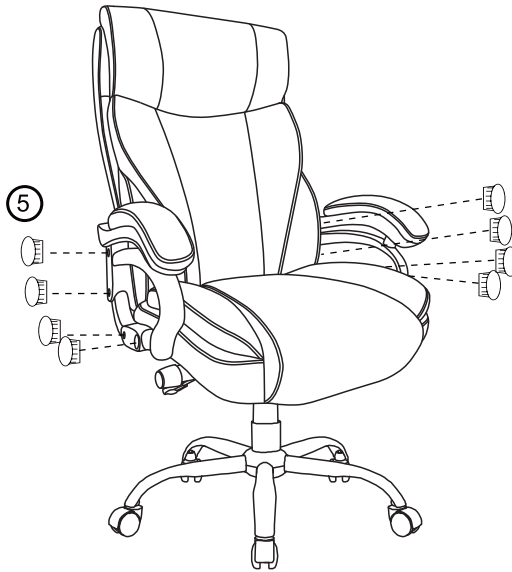

**Congratulations! You've
assembled your chair.**

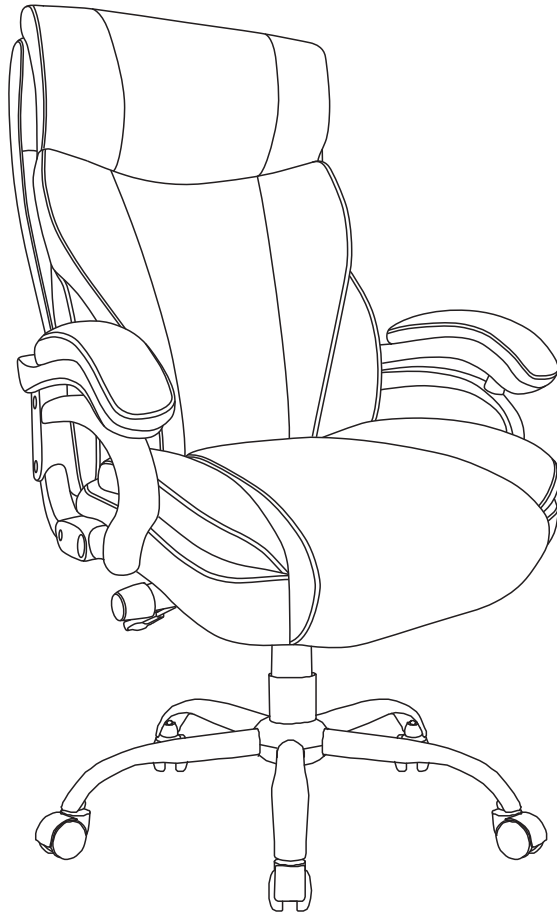

INSTRUCTIONS FOR USE

1. Lumbar Support Adjuster

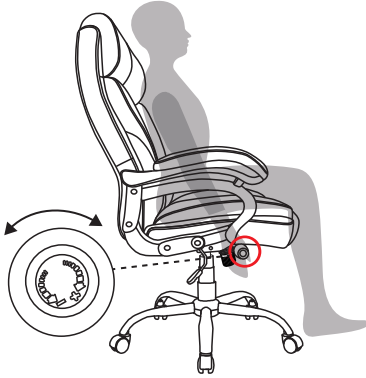

To increase lumbar support:
While seated, turn knob
forward (toward + sign).



To decrease lumbar support:
While seated, turn knob
backward (toward - sign).

* You can customize the level of support for the lower back by turning the knob.

2. Seat Height: Paddle-shaped lever on the right side

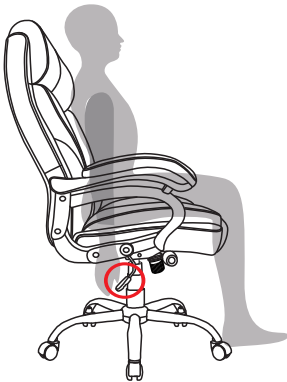

To raise:
While taking your weight off
chair, lift lever up.



To lower:
While seated, lift lever up.

* At the proper height, your feet should rest flat on the floor.

INSTRUCTIONS FOR USE

3. Tilt Tension: Long stem under the seat cushion with knob

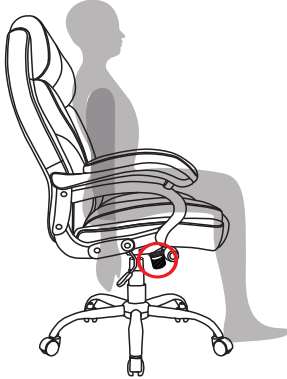

To increase tension:
While seated, turn knob
forward (toward + sign).



To decrease tension:
While seated, turn knob
backward (toward - sign).

* Set the tilt tension to control the resistance you feel when leaning back.

4. Operating the tilt lock out

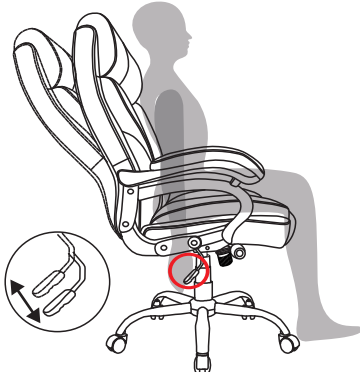

To let your chair tilt back, pull
the control handle out.

To stop your chair from tilting, sit
forward, then push the control
handle in.

SAFETY AND MAINTENANCE

- Do not stand on the chair, Do Not use the chair as stepladder.
- Use this product for seating one person at a time.
- Do not use the chair unless all bolts and screws are firmly secured.
- Avoid contact with sharp objects to prevent puncturing the fabric.
- Every 6 months, check all bolts and screws to ensure they are tight.
- To clean, spot clean only using a damp towel and mild cleaner, first test on a small,, obscure area of fabric.
- Chair weight limit not to exceed 350 lbs.

SAFETY INFORMATION



Sit in the center of the chair, with your back to the backrest



Do not sit at the front edge of the chair



Do not stand on the chair



Do not use the chair with more than one person



Do not push the chair around when a person is sitting in it



Do not push down on the backrest when a person is reclined



Do not place all your weight on the backrest only