

# ASSEMBLY INSTRUCTIONS

## TABLE

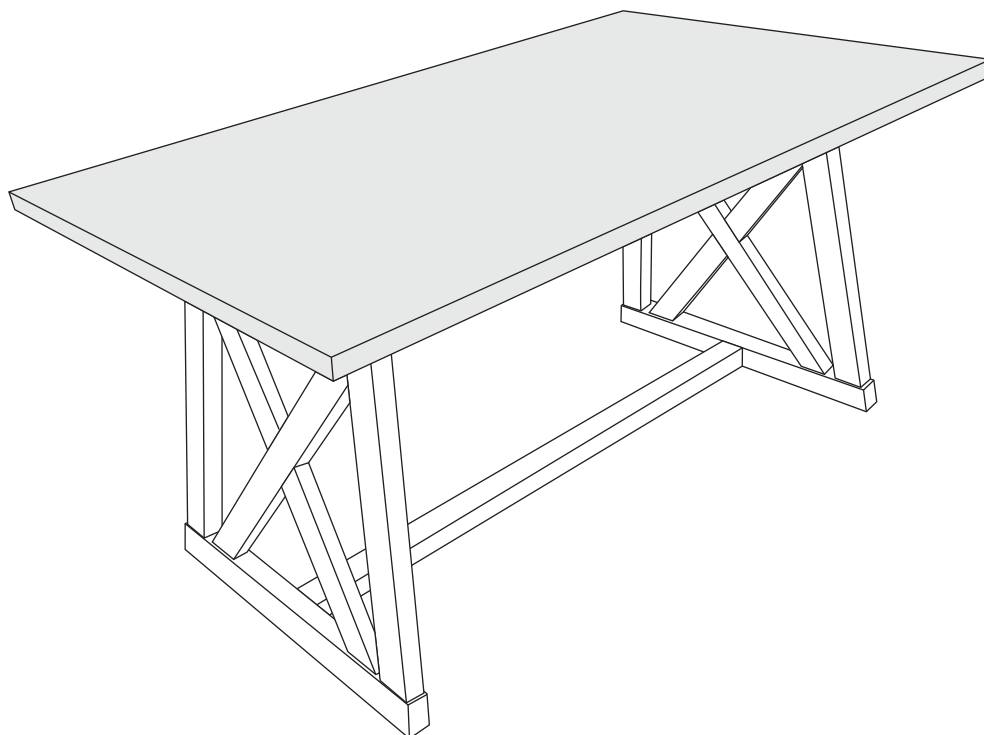

### IMPORTANT NOTE:

- PLACE ALL PARTS ON A CLEAN AND SMOOTH SURFACE SUCH AS A RUG OR CARPET TO AVOID THE PARTS FROM BEING SCRATCHED.
- BEFORE YOU BEGIN, KINDLY FOLLOW THE ASSEMBLY INSTRUCTIONS STEP BY STEP.
- DO NOT TIGHTEN ALL SCREWS AND BOLTS UNTIL THE TABLE IS FULLY SET-UP.

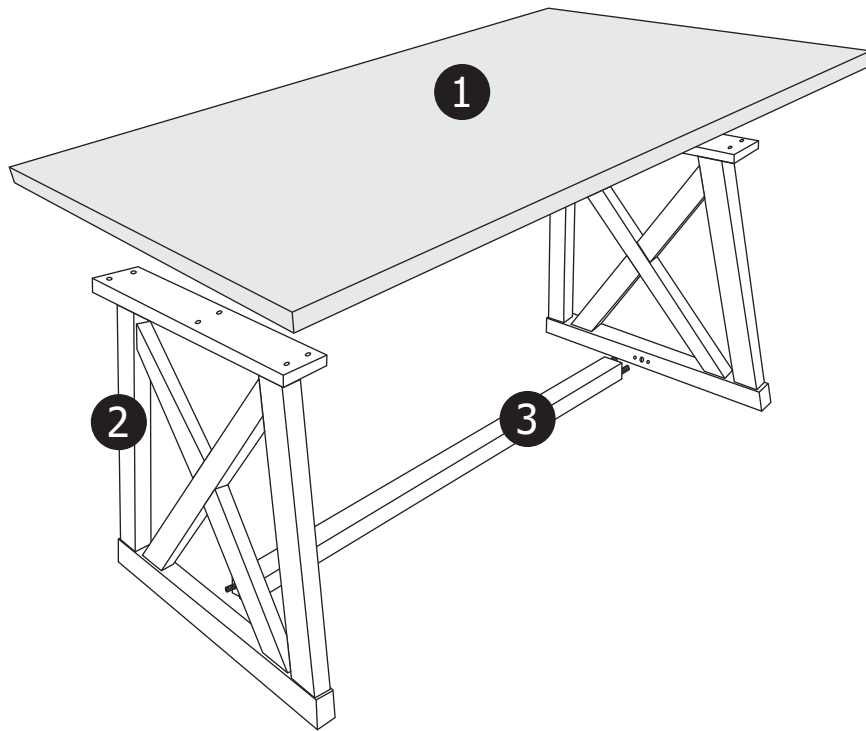

**CARTON CONTENT:**

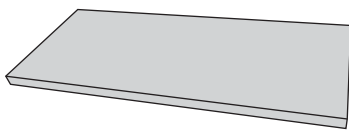

1 x 1

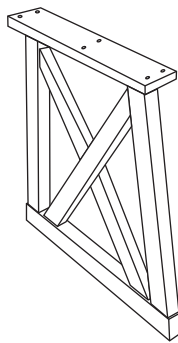

2 x 2

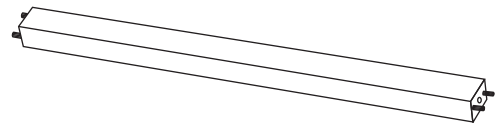

3 x 1

BENCH PART LISTS			
NO.	DESCRIPTION	SKETCH	QTY
1	TABLE TOP		1PC
2	LEG FRAME		2PCS
3	STRETCHER		1PC

BENCH HARDWARE LISTS			
NO.	DESCRIPTION	SKETCH	QTY
A	JCBC SCREW M6 X 40MM		12PCS
B	JCBB SCREW M8 X 60MM		2PCS
C	SPRING WASHER M6 X 13MM		12PCS
D	FLAT WASHER M6 X 18MM		12PCS
E	SPRING WASHER M8 X 15MM		2PCS
F	FLAT WASHER M8.5 X 18MM		2PCS
G	ALLEN KEY M4 X 65		1PC
H	ALLEN KEY M5 X 65		1PC

### STEP 1

Place the Table Top (1) on a flat & soft surface to prevent scratches. Then, attach the Leg Frame (2) to the Table Top (1).

Secure using JCBC screw M6 x 40mm(A), spring washer(C) & flat washer(D). Tighten up with Allen Key(G).

**PLEASE DO NOT FULLY TIGHTEN THE SCREWS UNTIL FINAL STEPS.**

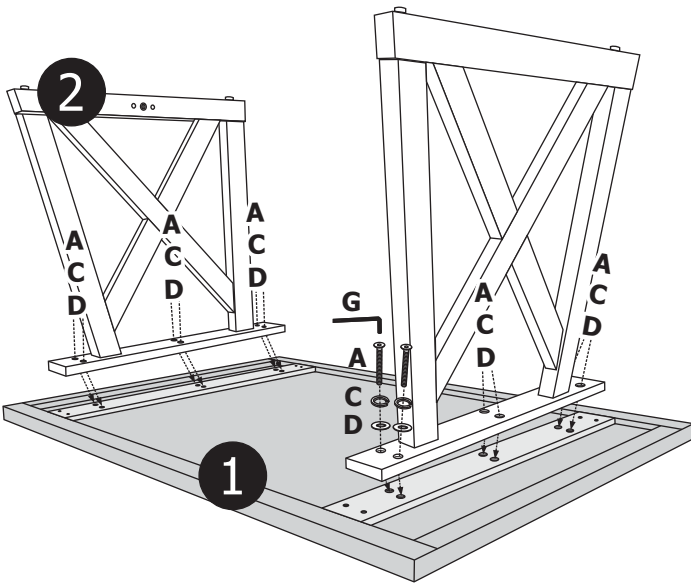

### STEP 2

Attach the Stretcher (3) to the Leg Frame (2) using JCBB screw M8 x 60mm(B), spring washer (E) & flat washer (F). Tighten up with Allen Key(H).

**FULLY TIGHTEN UP ALL THE SCREWS AT THIS TIME.**

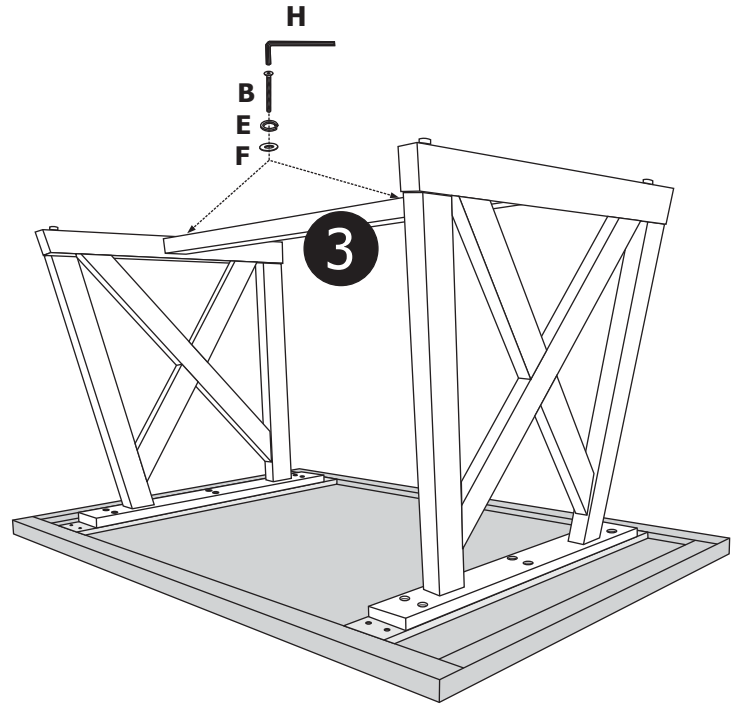

ASSEMBLY COMPLETE!

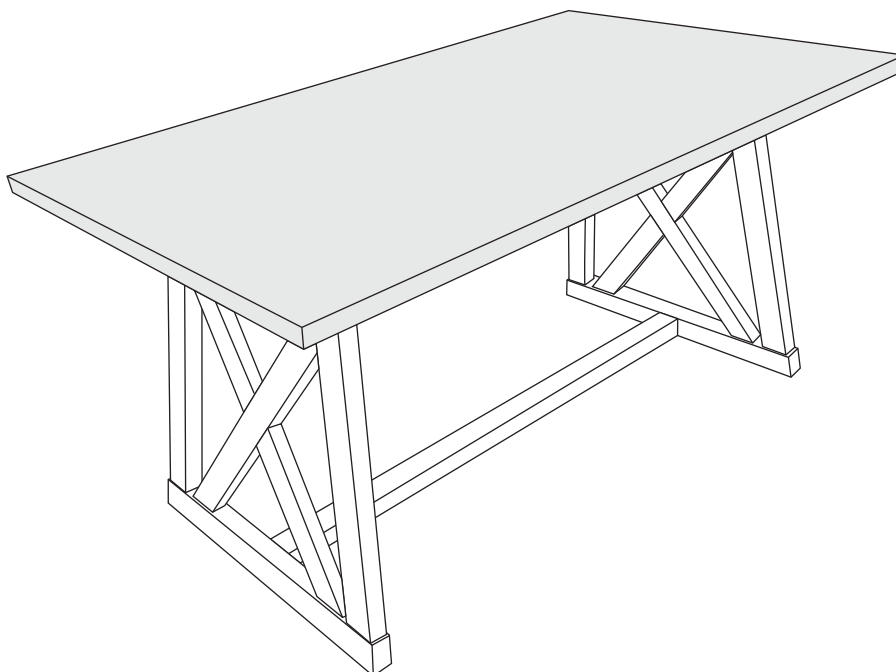

# ASSEMBLY INSTRUCTIONS

## DINING CHAIR

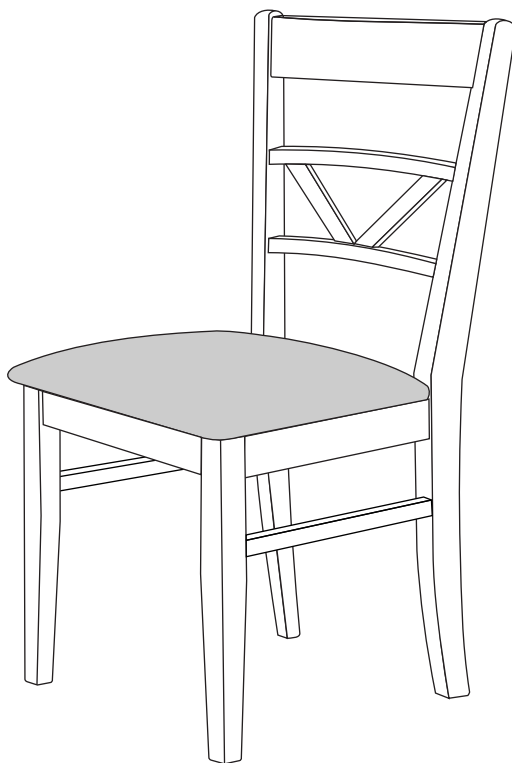

### **IMPORTANT NOTE:**

- PLACE ALL PARTS ON A CLEAN AND SMOOTH SURFACE SUCH AS A RUG OR CARPET TO AVOID THE PARTS FROM BEING SCRATCHED.
- BEFORE YOU BEGIN, KINDLY FOLLOW THE ASSEMBLY INSTRUCTIONS STEP BY STEP.
- DO NOT TIGHTEN ALL SCREWS AND BOLTS UNTIL THE CHAIR IS FULLY SET-UP.

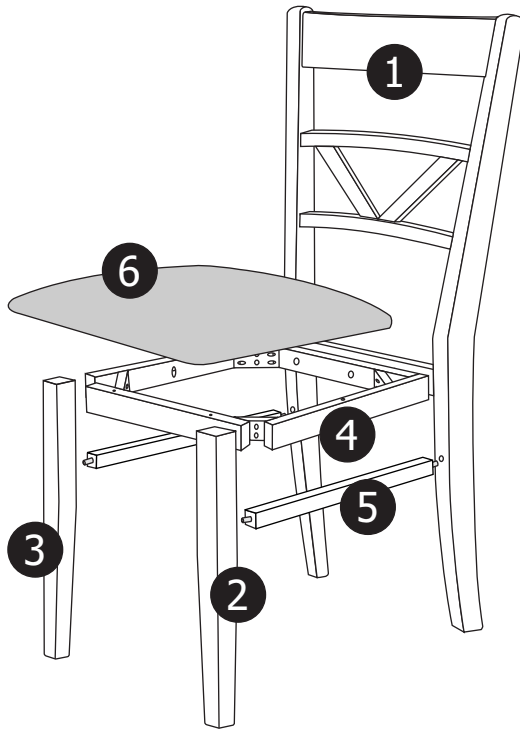

**CARTON CONTENT:**



**1 x 4**



**2 x 4**



**3 x 4**

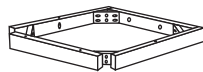

**4 x 4**



**5 x 8**



**6 x 4**

CHAIR PART LISTS			
NO.	DESCRIPTION	SKETCH	QTY
1	CHAIR BACK		4PCS
2	FRONT LEG (R)		4PCS
3	FRONT LEG (L)		4PCS
4	BOX SEAT		4PCS
5	SIDE STRETCHER(L/R)		8PCS
6	CUSHION SEAT		4PCS

CHAIR HARDWARE LISTS			
NO.	DESCRIPTION	SKETCH	QTY
A	JCBC SCREW M6 X 70MM		16PCS
B	JCBC SCREW M6 X 50MM		16PCS
C	JCBC SCREW M6 X 35MM		8PCS
D	SPRING WASHER M6 X 13.5MM		40PCS
E	FLAT WASHER M6 X 18MM		40PCS
F	SCREW M4 X 32MM		32PCS
G	ALLEN KEY M4 X 25 X 65		1PC

### STEP 1

Place the Chair Back(1) on a flat & soft surface to prevent scratches.

Attach the Box Seat (4) to the Chair Back(1).

Secure from the center using flat washer(E), spring washer(D) & JCBC screw M6 x 35mm(C).

Secure the 2 corners using flat washer(E), spring washer(D) & JCBC screw M6 x 70mm(A). Tighten up with Allen Key(G).

**PLEASE DO NOT FULLY TIGHTEN THE SCREWS UNTIL FINAL STEPS.**

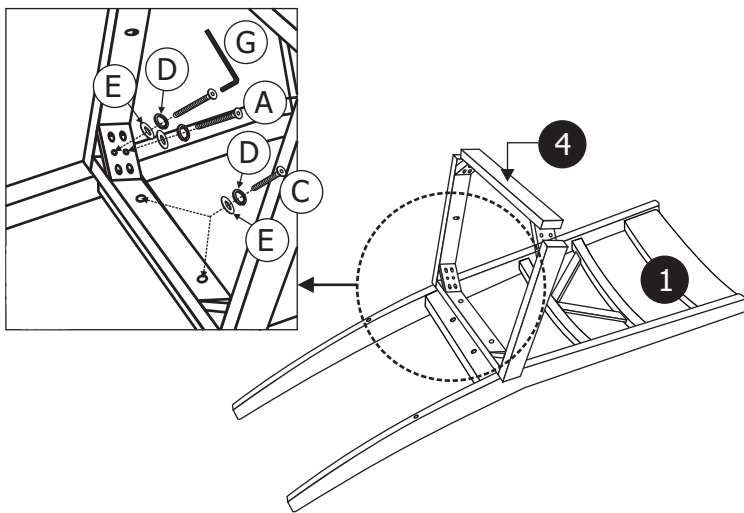

### STEP 2

Attach Front Legs(2 & 3) to the assembled chair back (1) with box seat(4) by using flat washer(E), spring washer(D) and JCBC screw M6 x 50mm(B). Only **SLIGHTLY** tighten by Allen Key(G) to ensure they are not falls out.

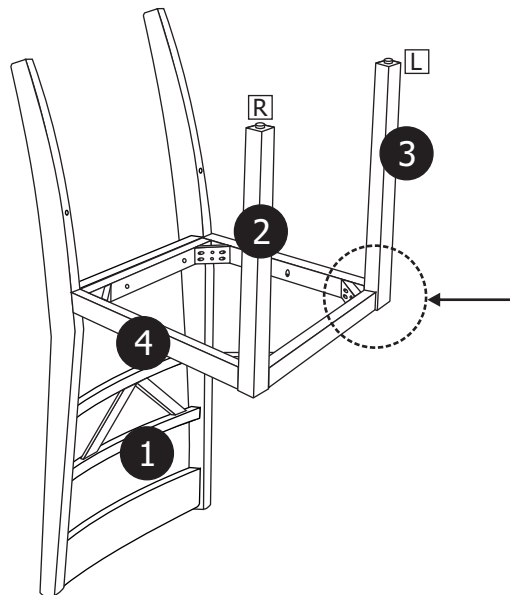
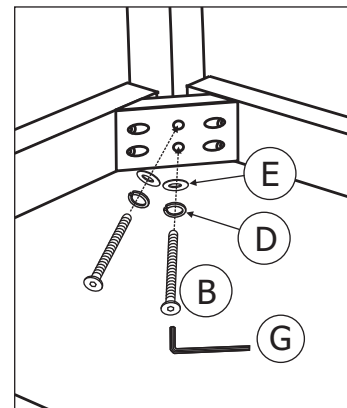

### STEP 3

Align the side stretcher (5) at proper position and tighten with screw (F) and drive it with Phillip Screwdriver (not provided). Then make sure all legs are level. Once level, tighten all the screws securely at this stage.

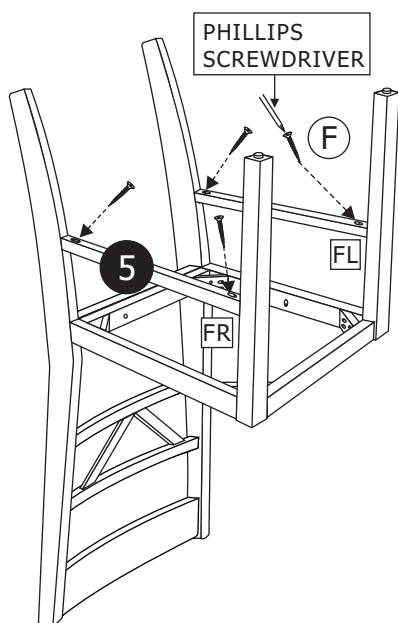

### STEP 4

Finally, attached the Cushion Seat (6) to the chair frame using screw (F) and drive it with Phillip Screwdriver (not provided).

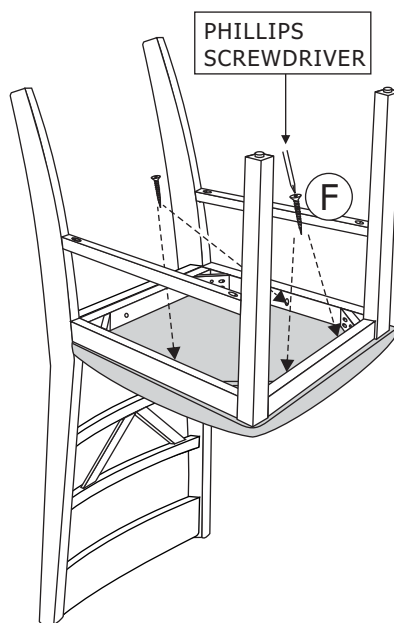

**ASSEMBLY COMPLETE!**

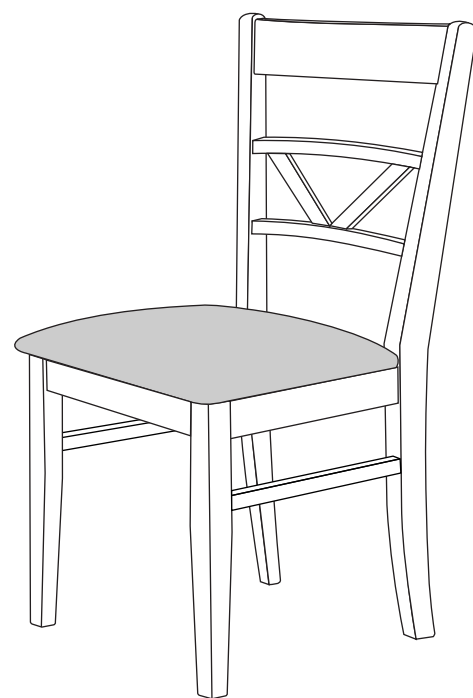

# ASSEMBLY INSTRUCTIONS

## BENCH

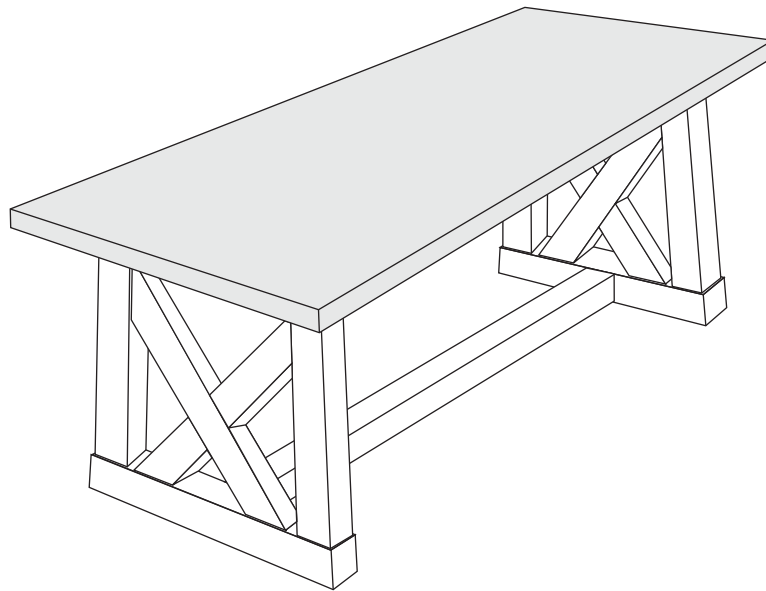

### IMPORTANT NOTE:

- PLACE ALL PARTS ON A CLEAN AND SMOOTH SURFACE SUCH AS A RUG OR CARPET TO AVOID THE PARTS FROM BEING SCRATCHED.
- BEFORE YOU BEGIN, KINDLY FOLLOW THE ASSEMBLY INSTRUCTIONS STEP BY STEP.
- DO NOT TIGHTEN ALL SCREWS AND BOLTS UNTIL THE BENCH IS FULLY SET-UP.

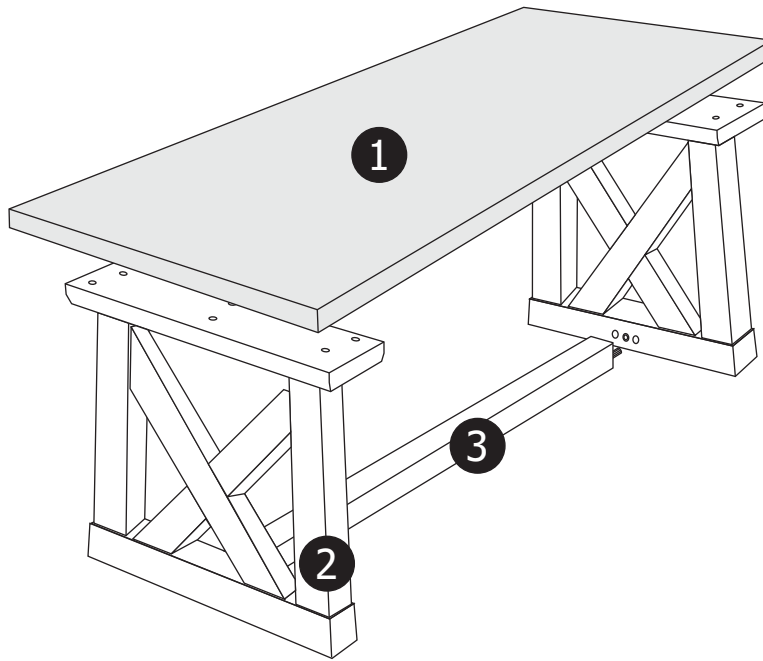

**CARTON CONTENT:**

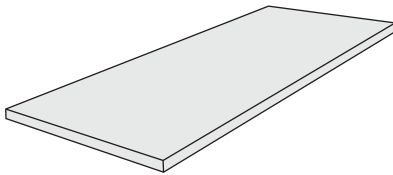

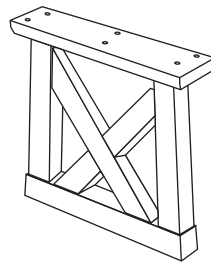

1 x 1



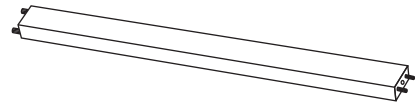



2 x 2



3 x 1

BENCH PART LISTS			
NO.	DESCRIPTION	SKETCH	QTY
1	BENCH SEAT		1PC
2	LEG FRAME		2PCS
3	STRETCHER		1PC

BENCH HARDWARE LISTS			
NO.	DESCRIPTION	SKETCH	QTY
A	JCBC SCREW M6 X 40MM		12PCS
B	JCBC SCREW M6 X 60MM		2PCS
C	SPRING WASHER M6 X 13MM		14PCS
D	FLAT WASHER M6 X 18MM		14PCS
E	ALLEN KEY M4 X 65		1PC

### STEP 1

Place the Bench Seat (1) on a flat & soft surface to prevent scratches. Then, attach the Leg Frame (2) to the Bench Seat (1). Secure using JCBC screw M6 x 40mm(A), spring washer(C) & flat washer(D). Tighten up with Allen Key(E). **PLEASE DO NOT FULLY TIGHTEN THE SCREWS UNTIL FINAL STEPS.**

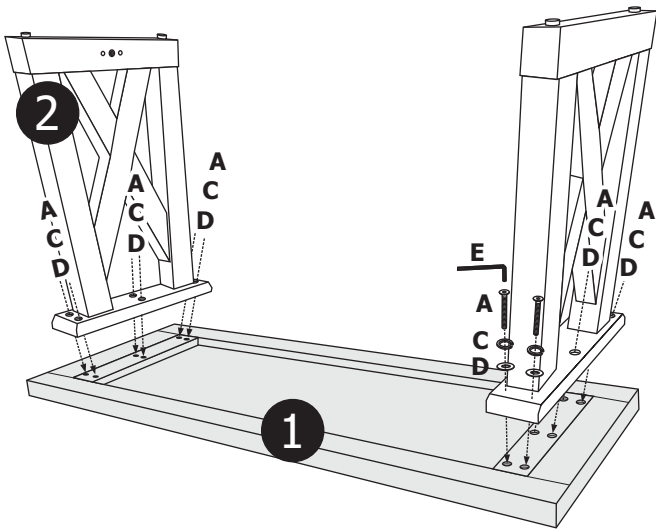

### STEP 2

Attach the Stretcher (3) to the Leg Frame (2) using JCBC screw M6 x 60mm(B), spring washer (C) & flat washer (D). Tighten up with Allen Key(E). **FULLY TIGHTEN UP ALL THE SCREWS AT THIS TIME.**

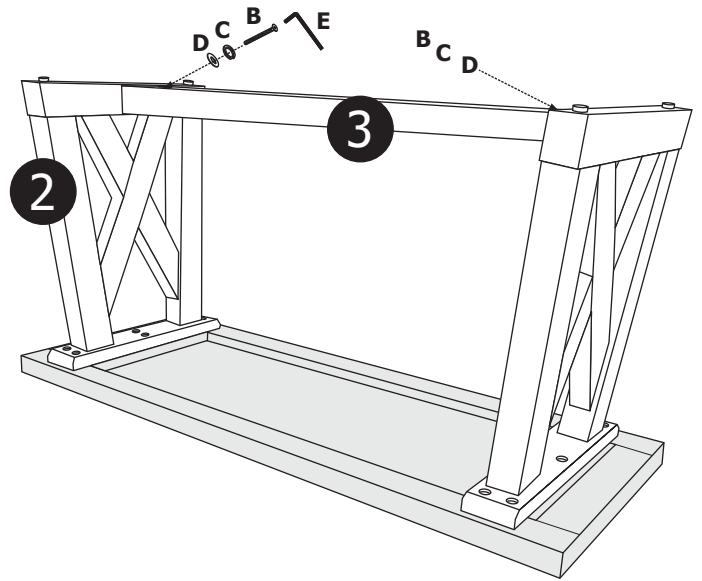

ASSEMBLY COMPLETE!

