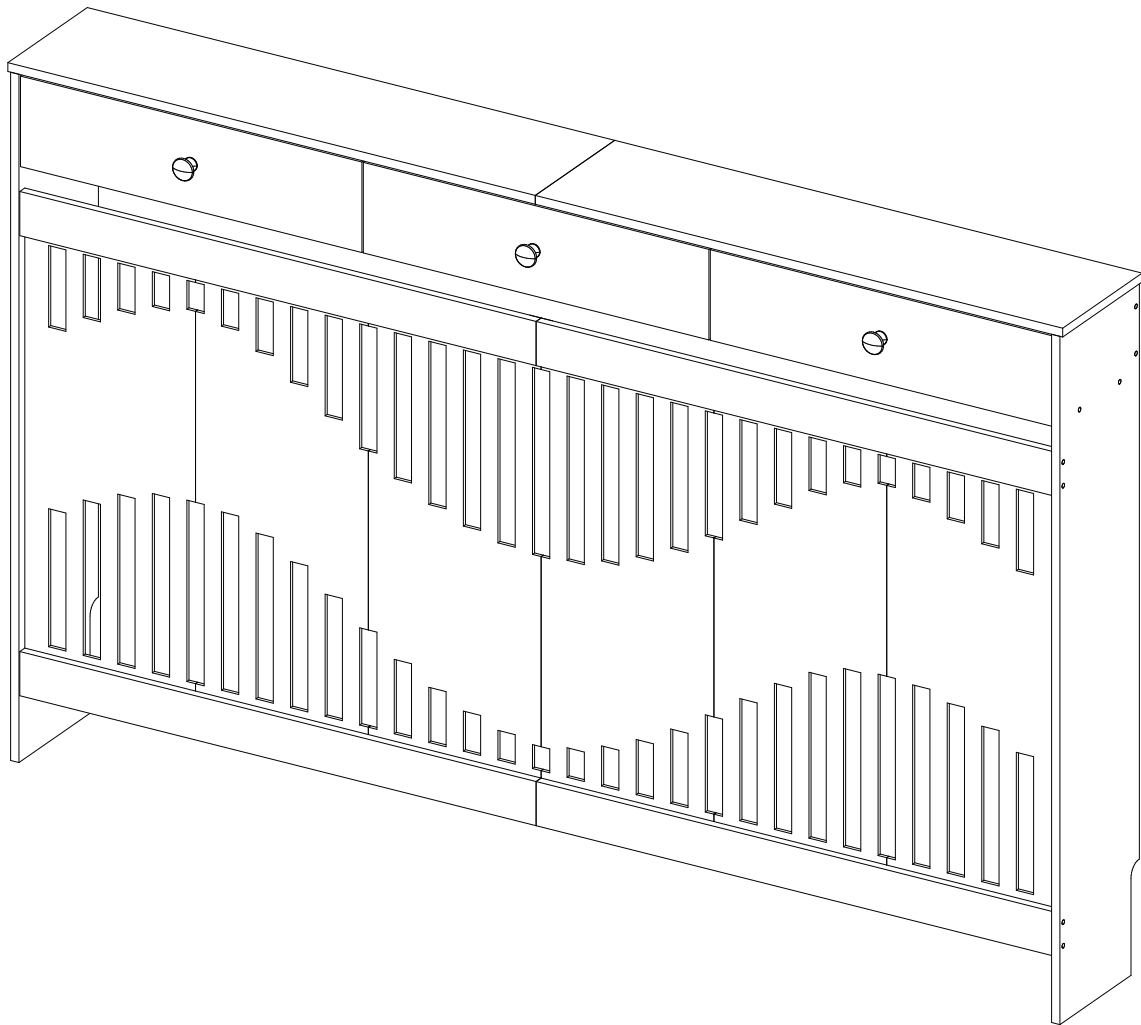


joolihome

LIVING



amazon

ebay

FIND US

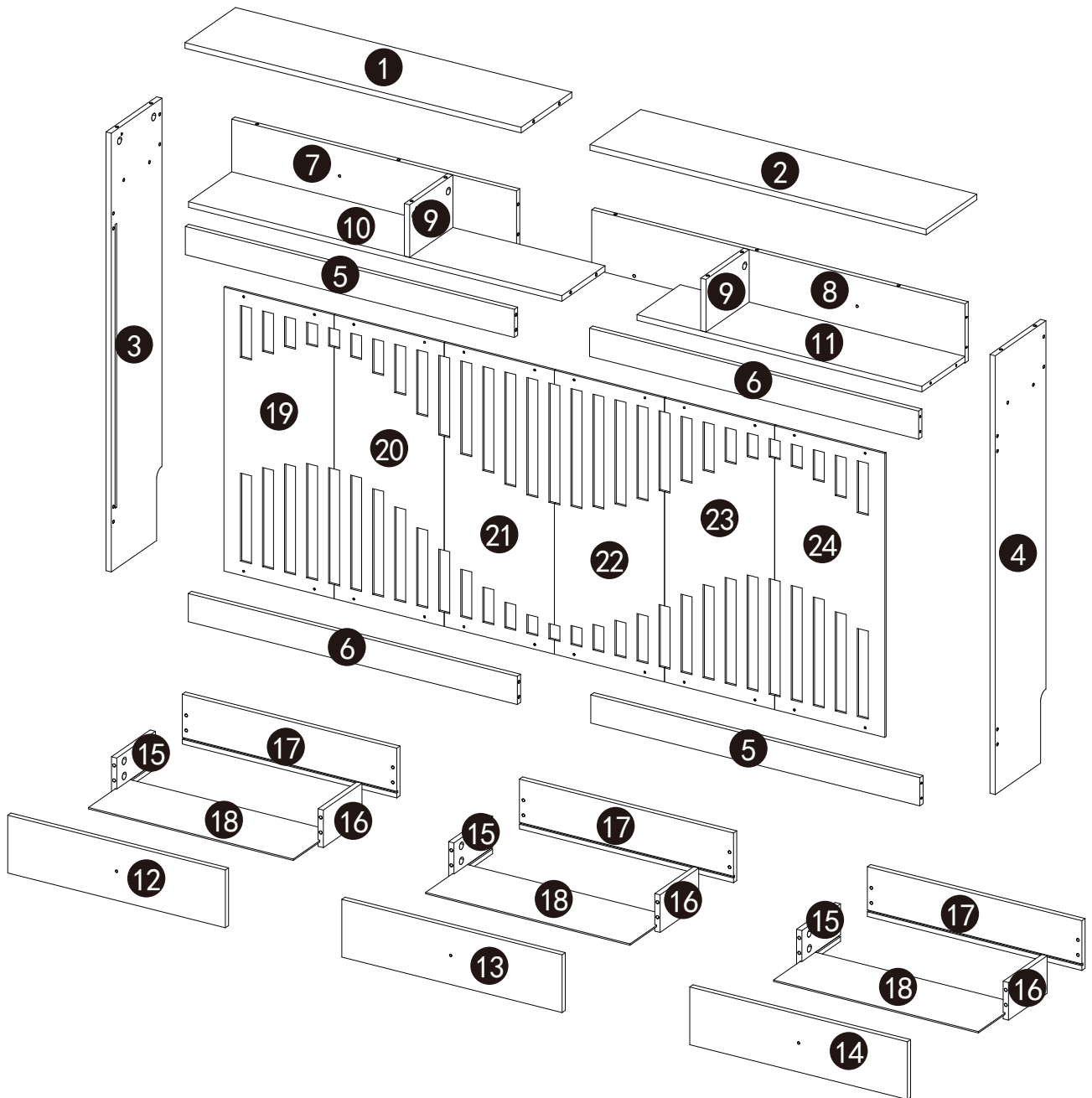
...

All ▾

joolihome

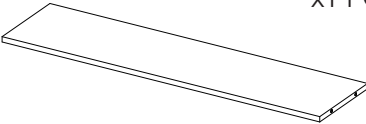
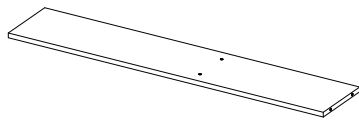
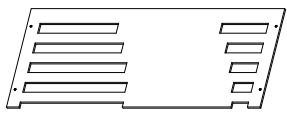
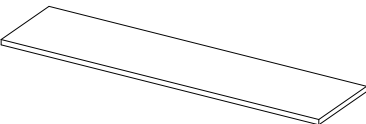
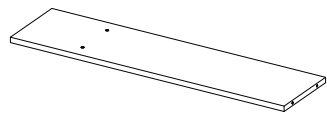
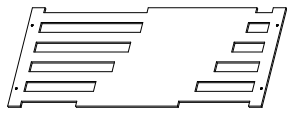
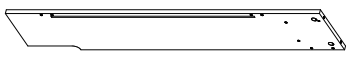
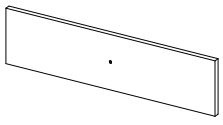
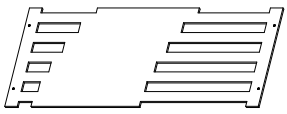
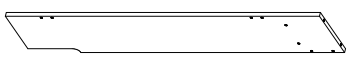
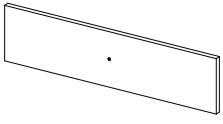
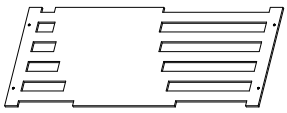
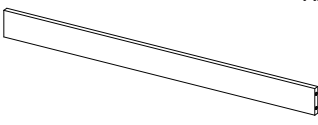
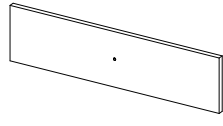
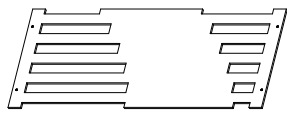
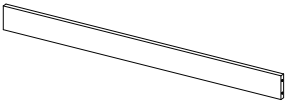
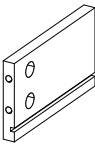
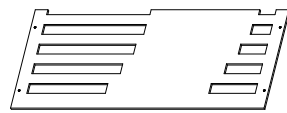
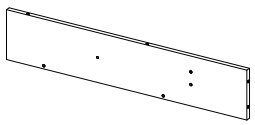
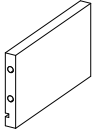
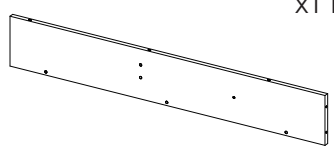
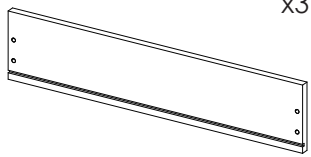
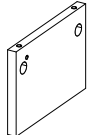
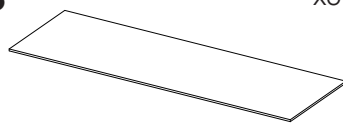


Plate number



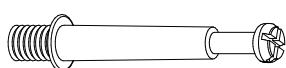



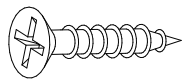

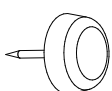


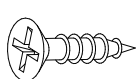

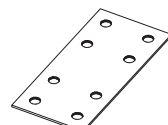
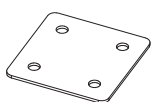
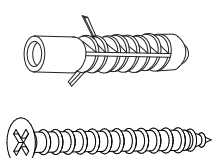
PARTS LIST

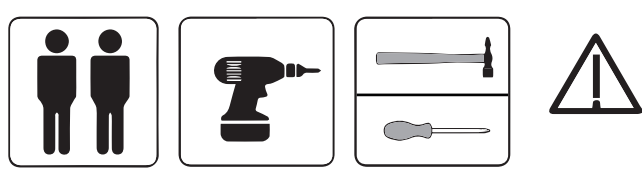
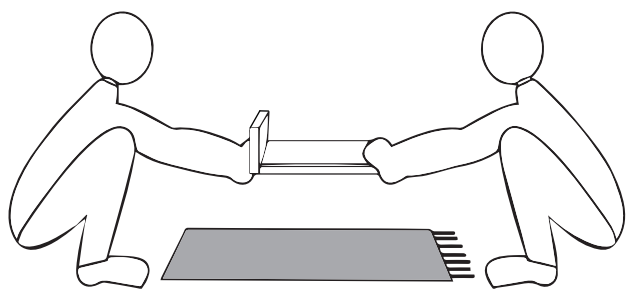
Unit: (mm)

<p>1  x1 PC</p>	<p>10  x1 PC</p>	<p>19  x1 PC</p>
<p>2  x1 PC</p>	<p>11  x1 PC</p>	<p>20  x1 PC</p>
<p>3  x1 PC</p>	<p>12  x1 PC</p>	<p>21  x1 PC</p>
<p>4  x1 PC</p>	<p>13  x1 PC</p>	<p>22  x1 PC</p>
<p>5  x2 PC</p>	<p>14  x1 PC</p>	<p>23  x1 PC</p>
<p>6  x2 PC</p>	<p>15  x3 PC</p>	<p>24  x1 PC</p>
<p>7  x1 PC</p>	<p>16  x3 PC</p>	
<p>8  x1 PC</p>	<p>17  x3 PC</p>	
<p>9  x2 PC</p>	<p>18  x3 PC</p>	

ACCESSORIES LIST

Unit: (mm)

<p>A 6x35 x25 PC</p> 	<p>B 15x10 x25 PC</p> 	<p>C x6 PC</p> 
<p>D 6x40 x10 PC</p> 	<p>E M3.5x14 x24 PC</p> 	<p>F M5x40/#3 x41 PC/x1 PC</p> 
<p>G Ø12x5 x4 PC</p> 	<p>H M4x16 x3 PC</p> 	<p>J x6 PC</p> 
<p>K M3.5x12 x48 PC</p> 	<p>L 21mm x36 PC</p> 	<p>M x4 PC</p> 
<p>N x4 PC</p> 	<p>O x2 PC</p> 	

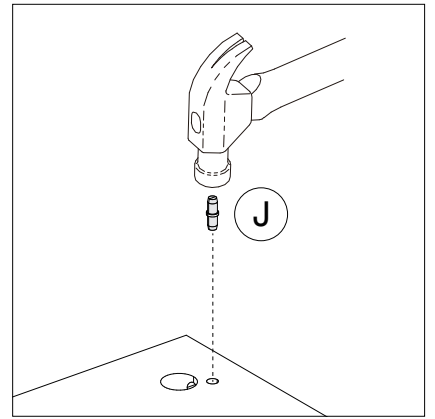
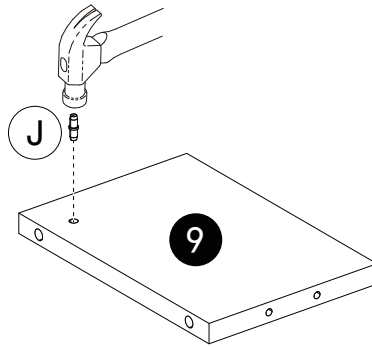
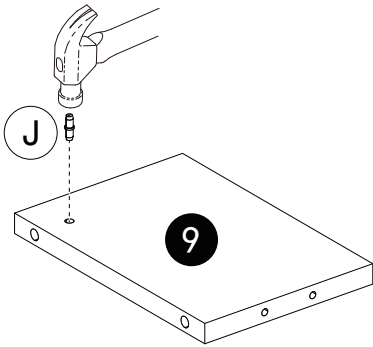


INSTALLATION INSTRUCTION

STEP 1

YOU WILL NEED

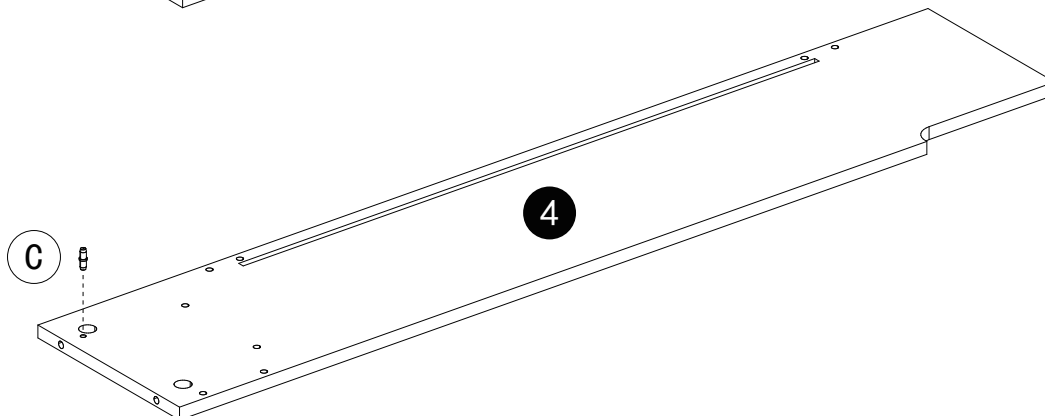
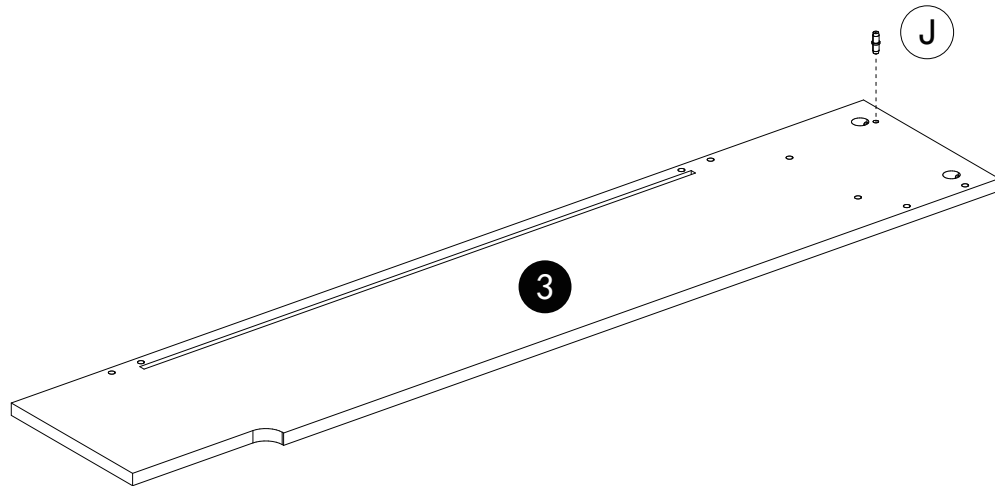
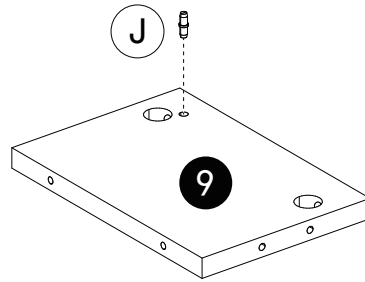
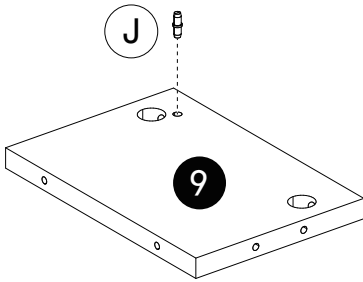
J x6



flip over



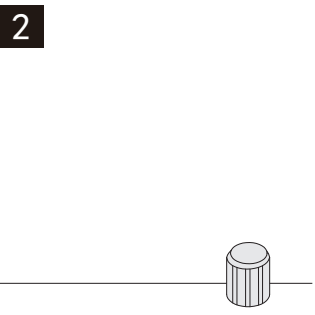
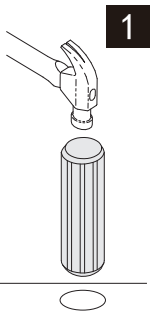
flip over



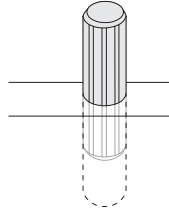
STEP 2

YOU WILL NEED

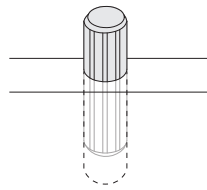
D x4



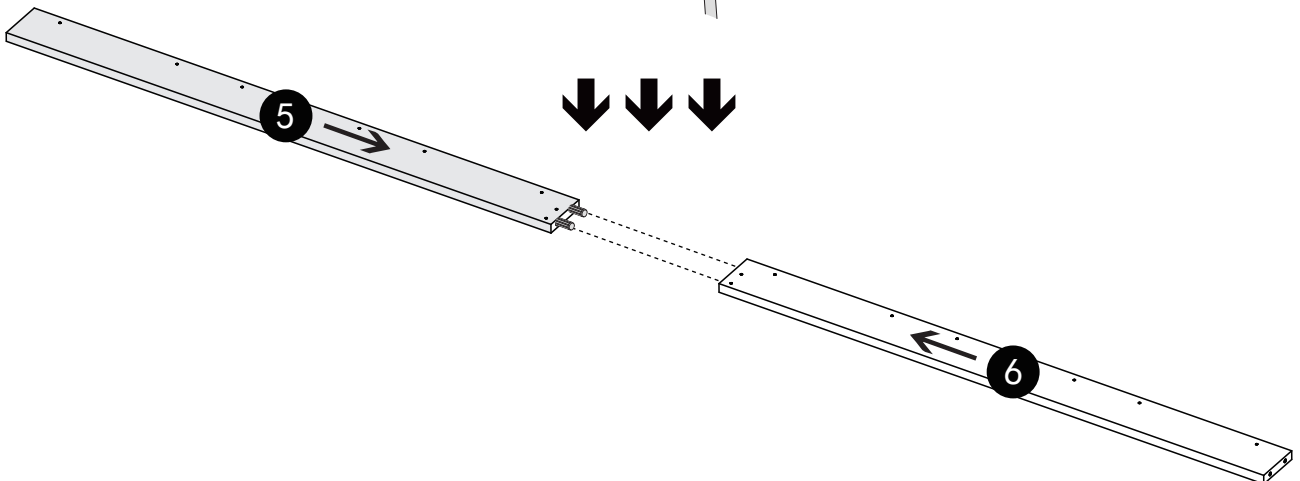
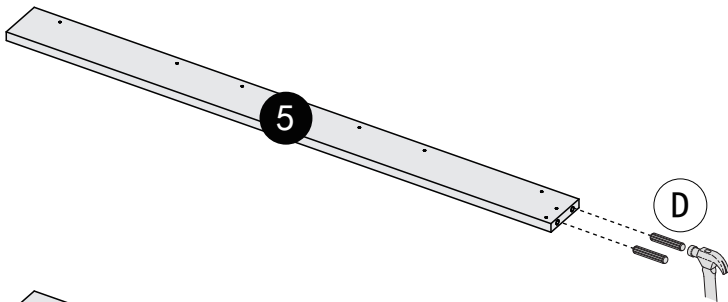
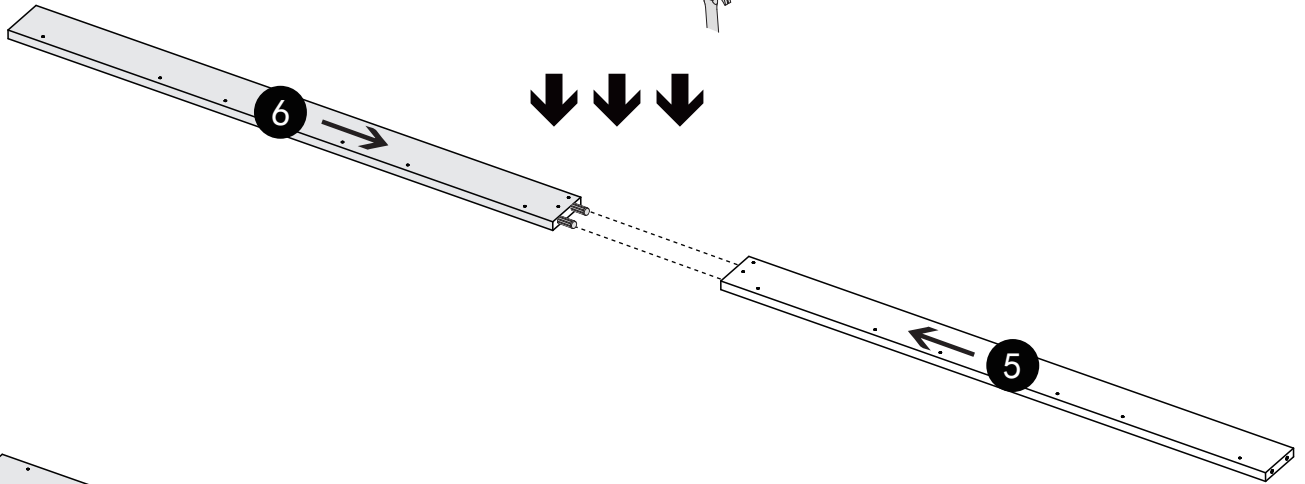
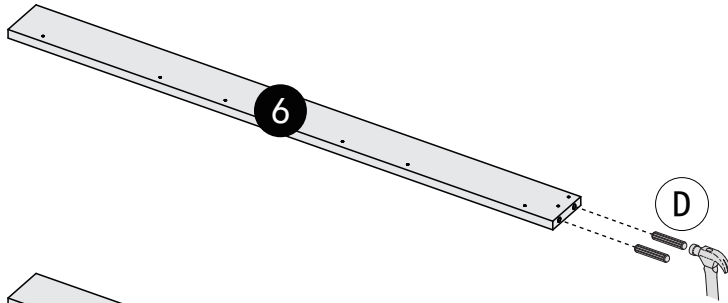
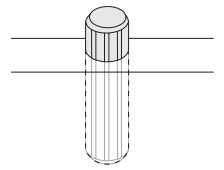
X



X



✓



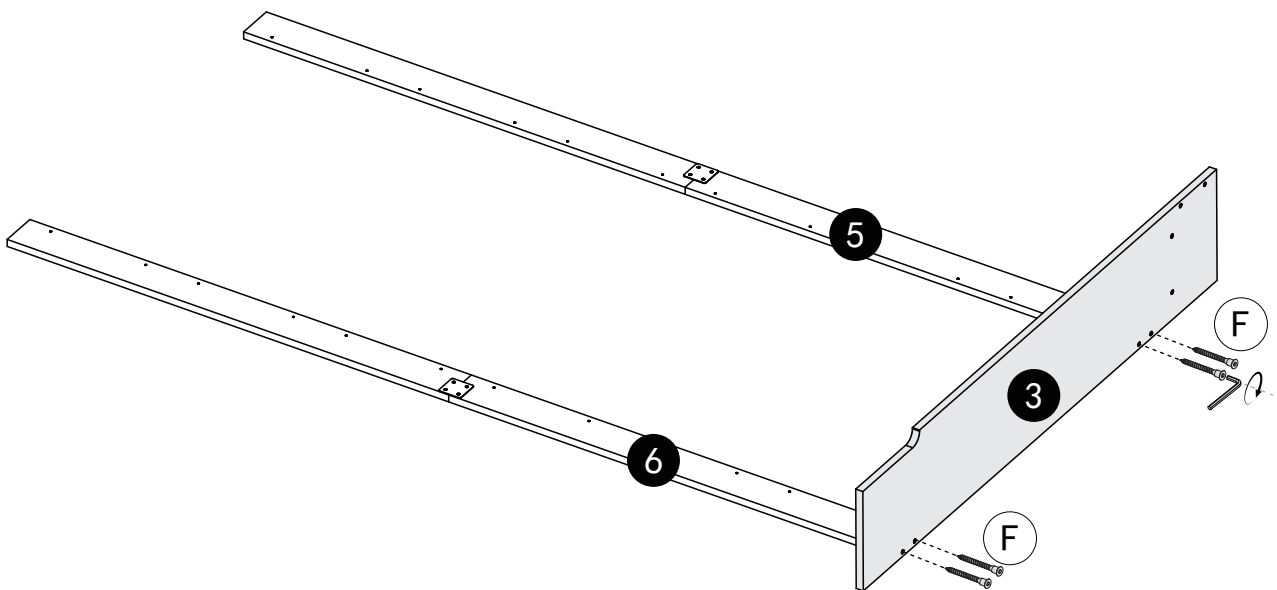
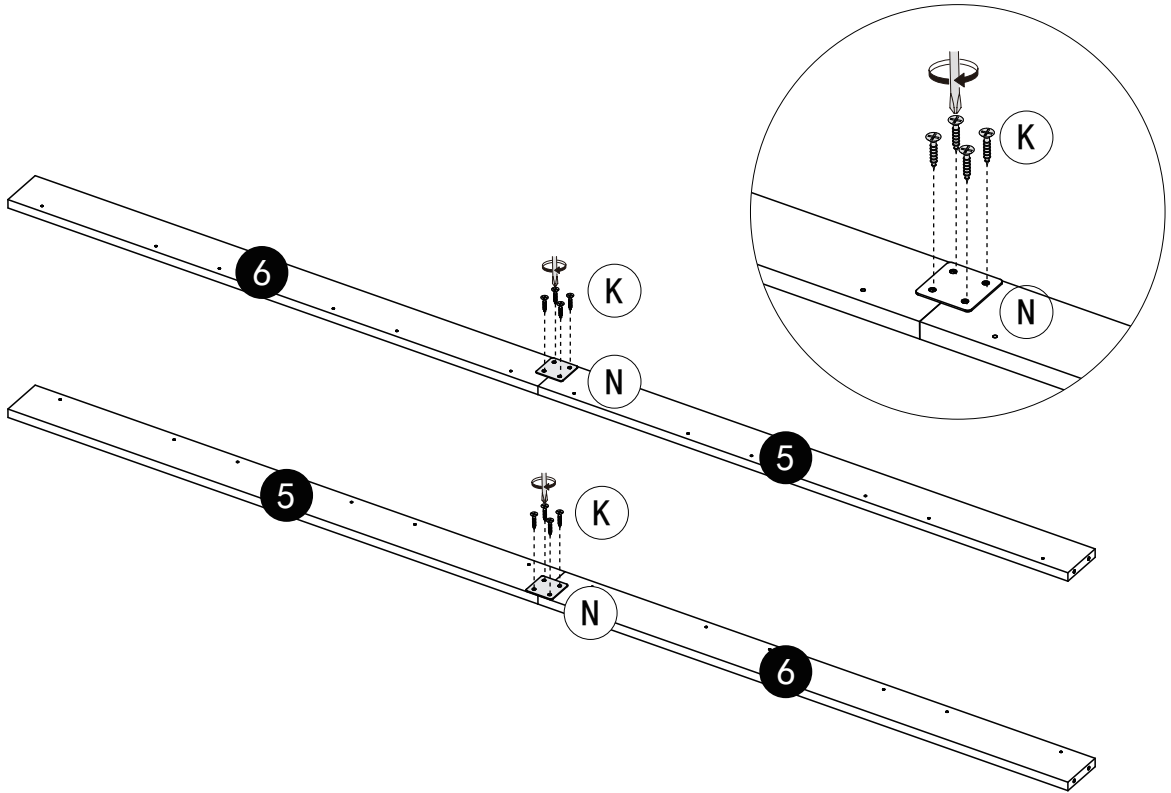
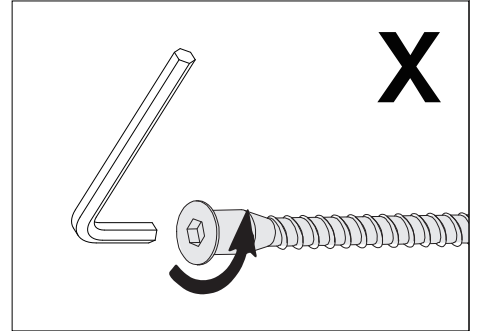
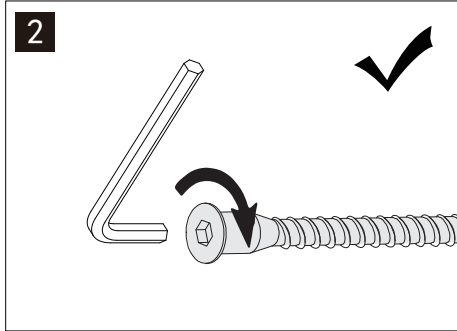
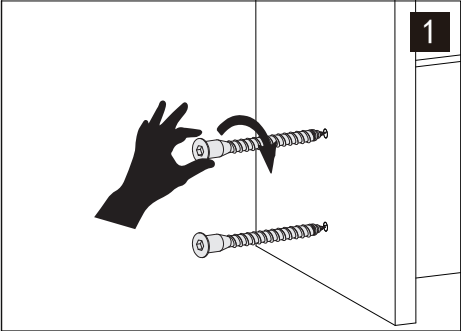
STEP 3

YOU WILL NEED

N x2

K x8

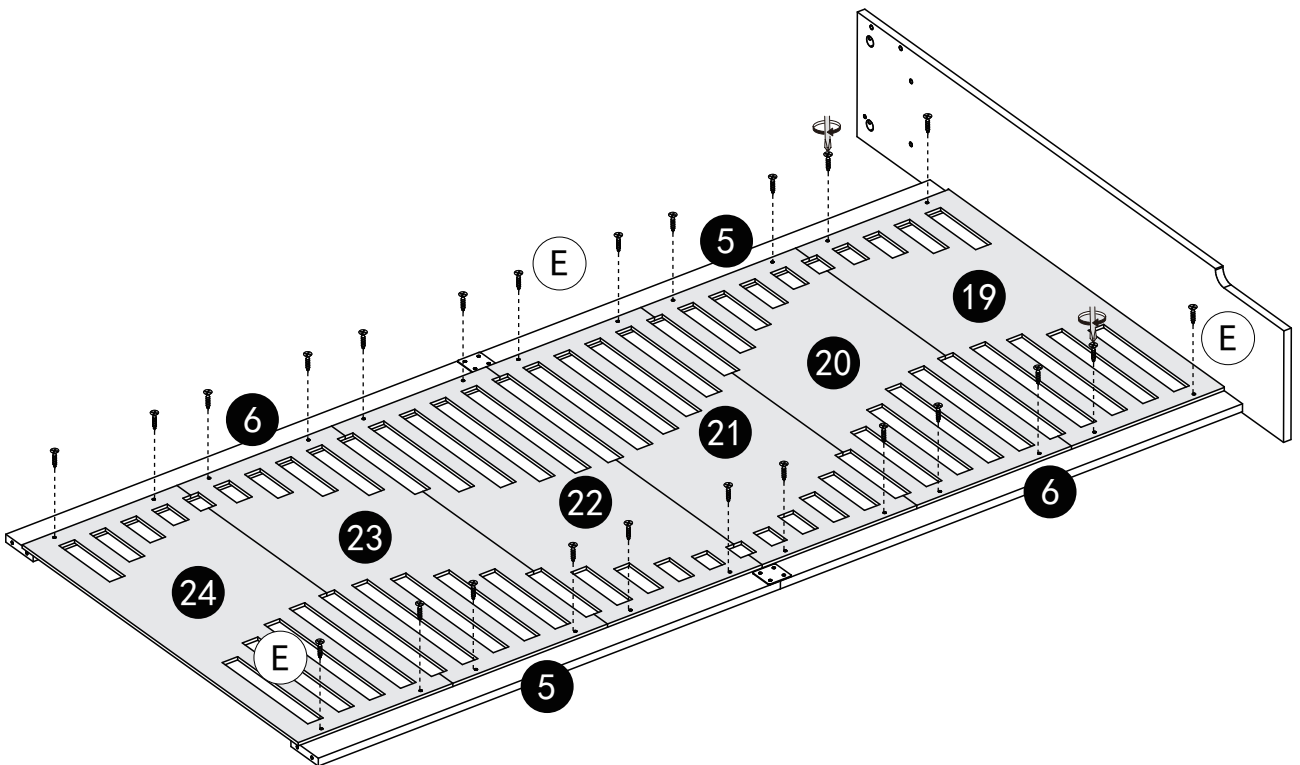
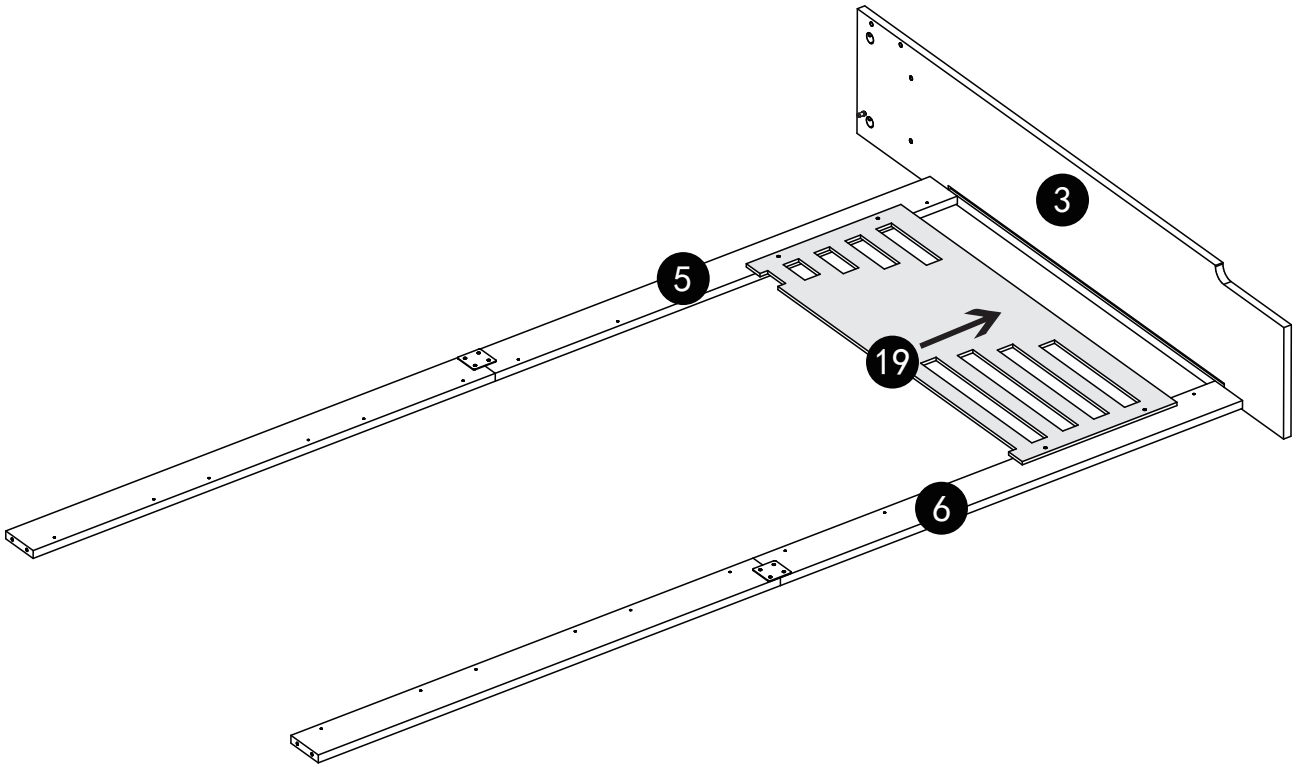
F x4



STEP 4

YOU WILL NEED

E x24



STEP 5

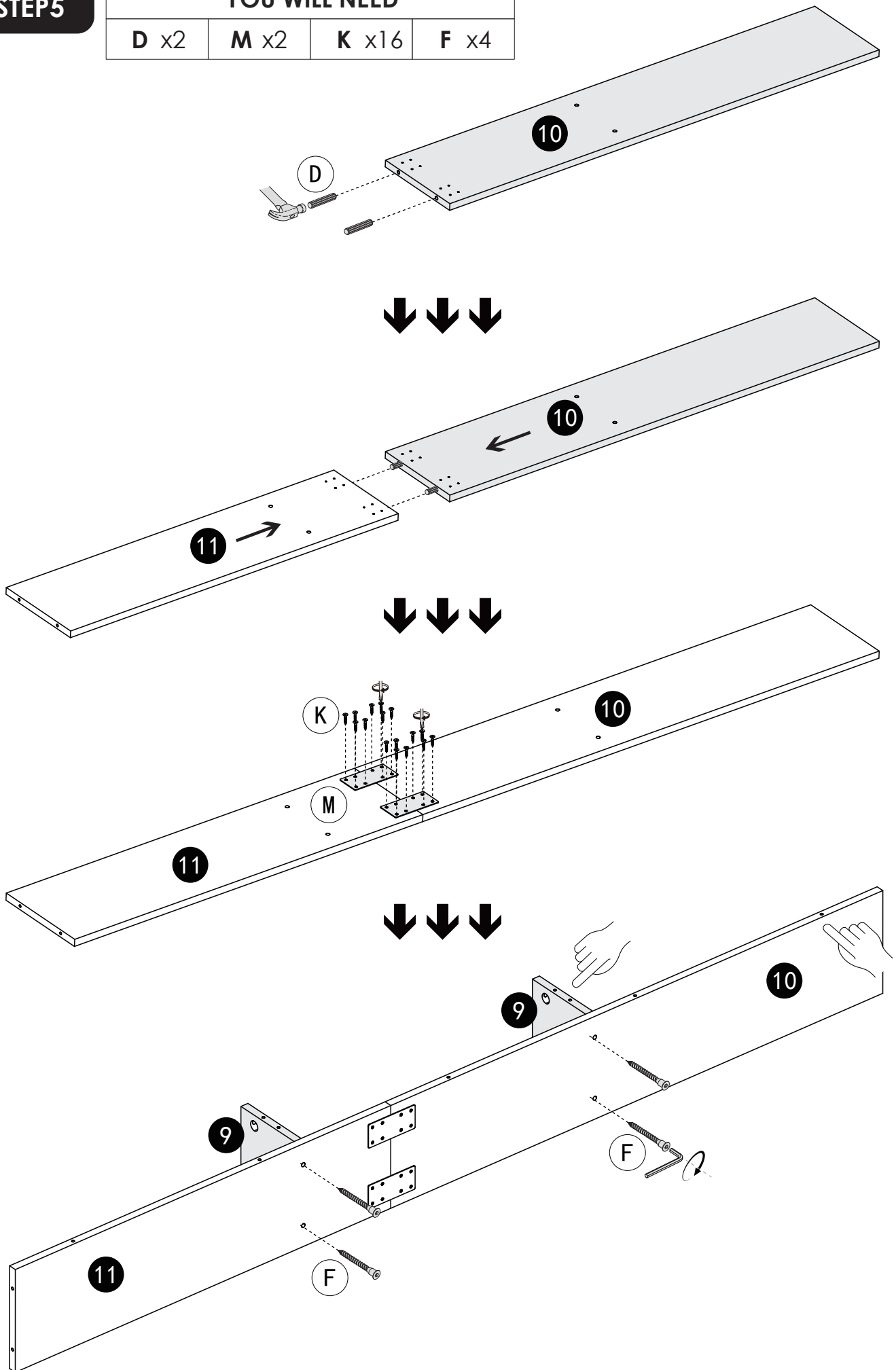
YOU WILL NEED

D x2

M x2

K x16

F x4



STEP 6

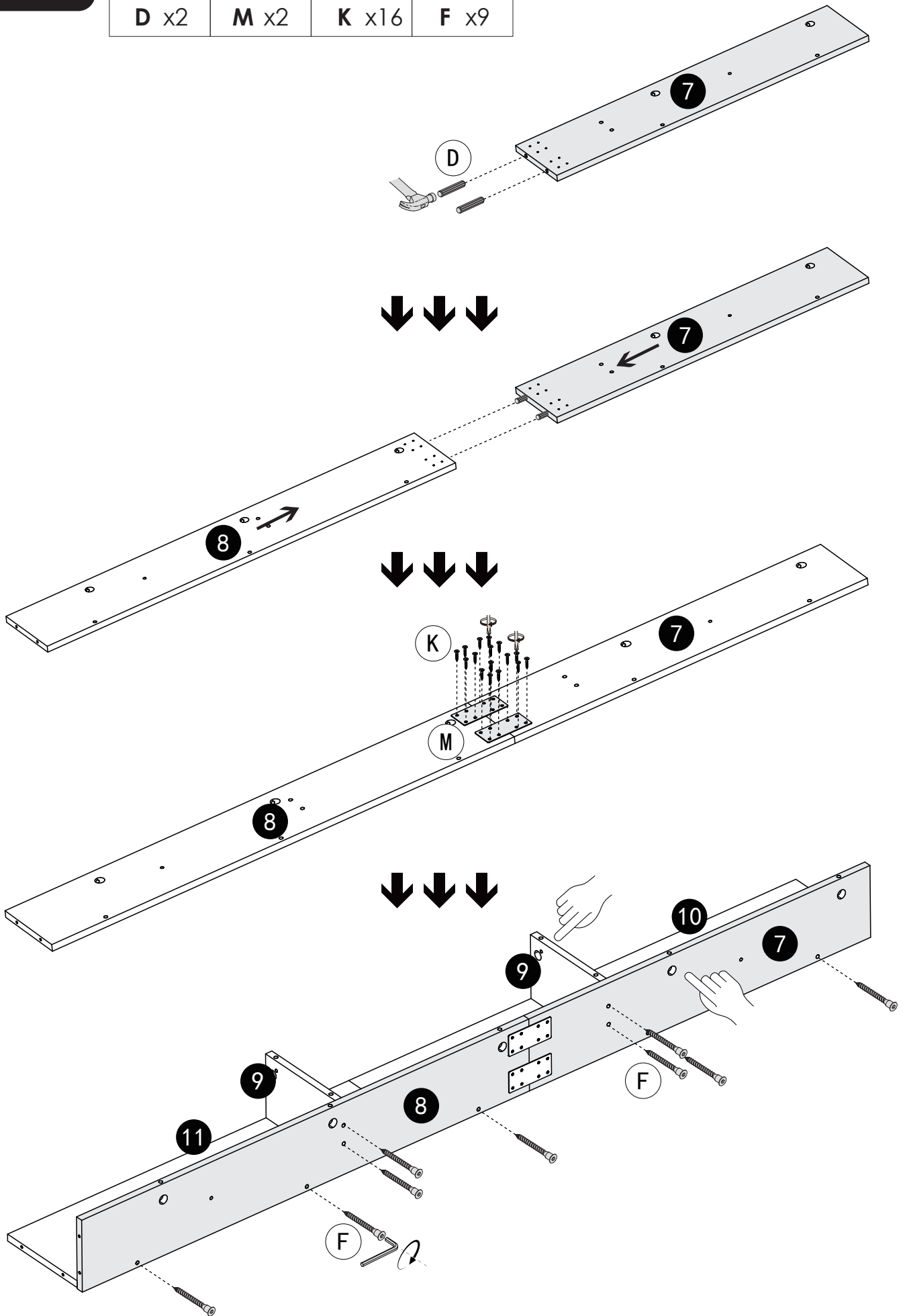
YOU WILL NEED

D x2

M x2

K x16

F x9

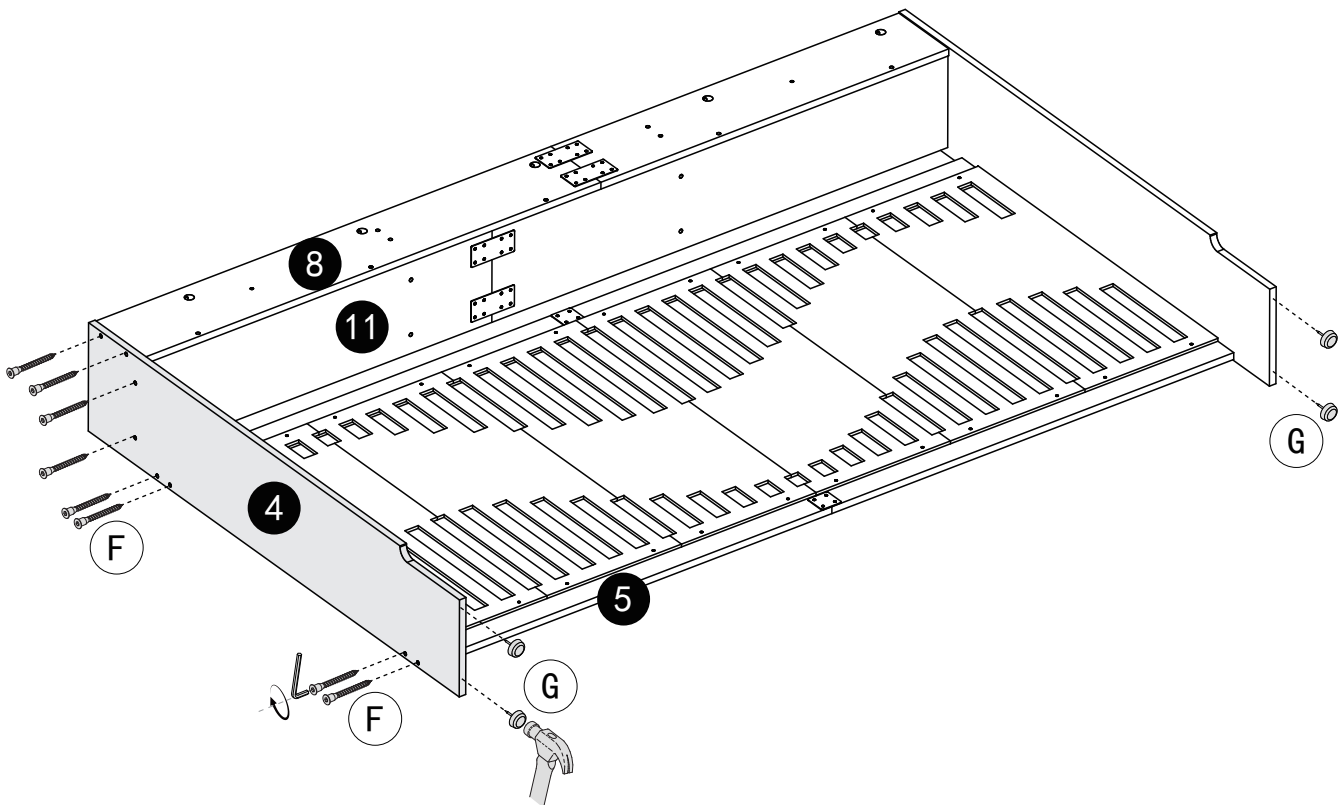
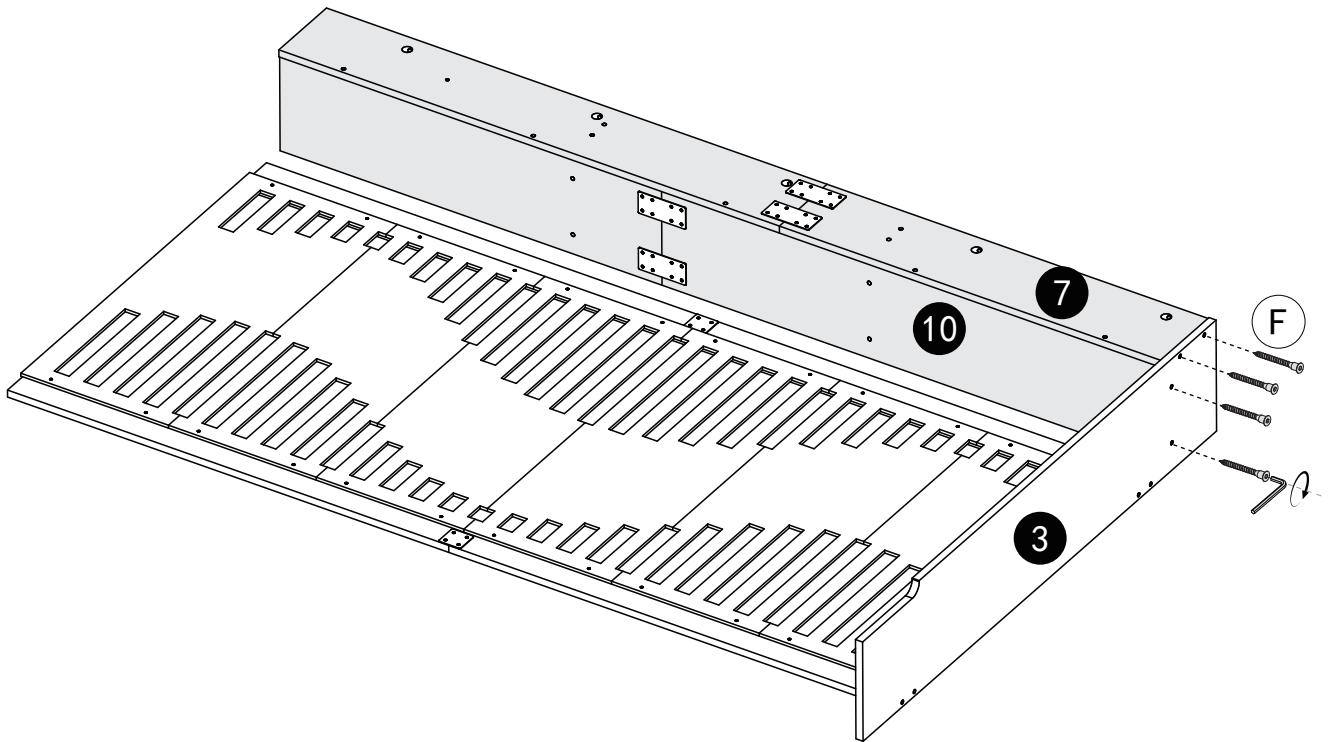


STEP 7

YOU WILL NEED

F x12

G x4



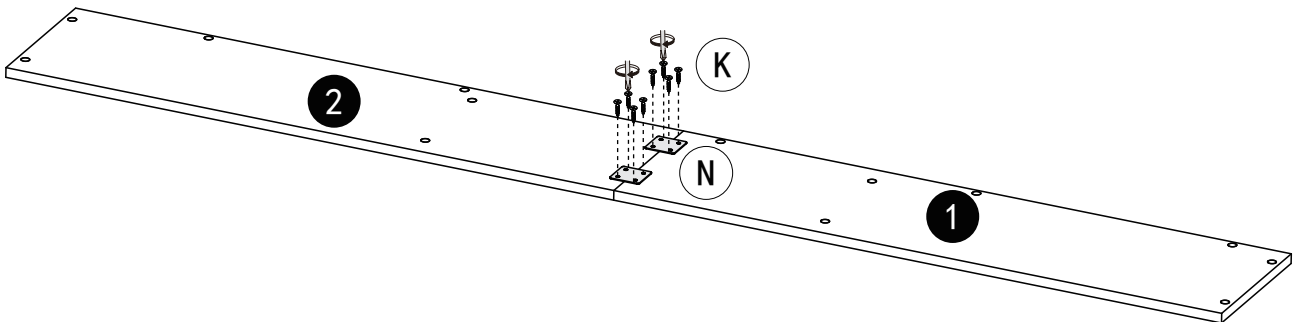
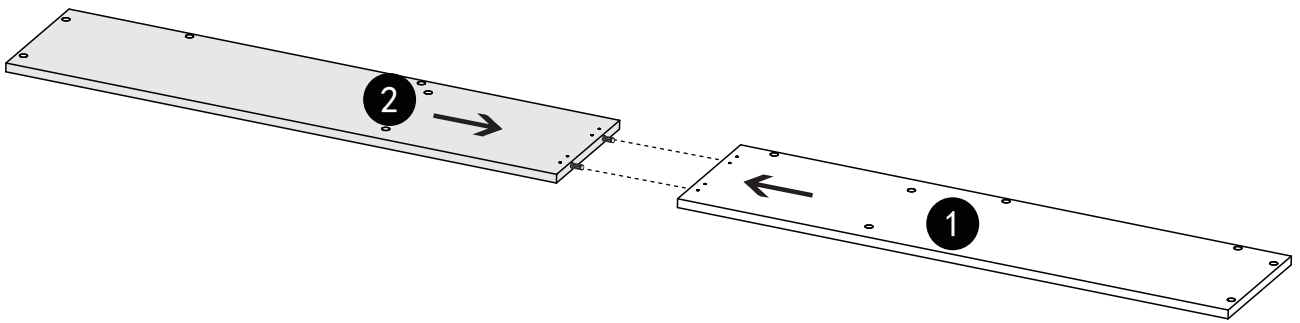
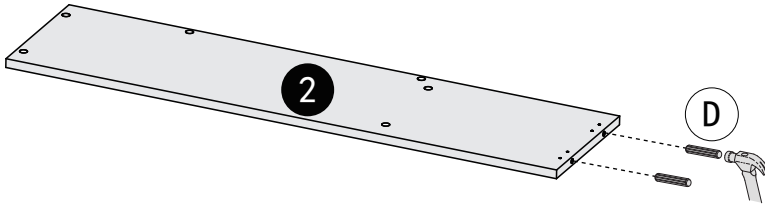
STEP 8

YOU WILL NEED

D x2

N x2

K x8



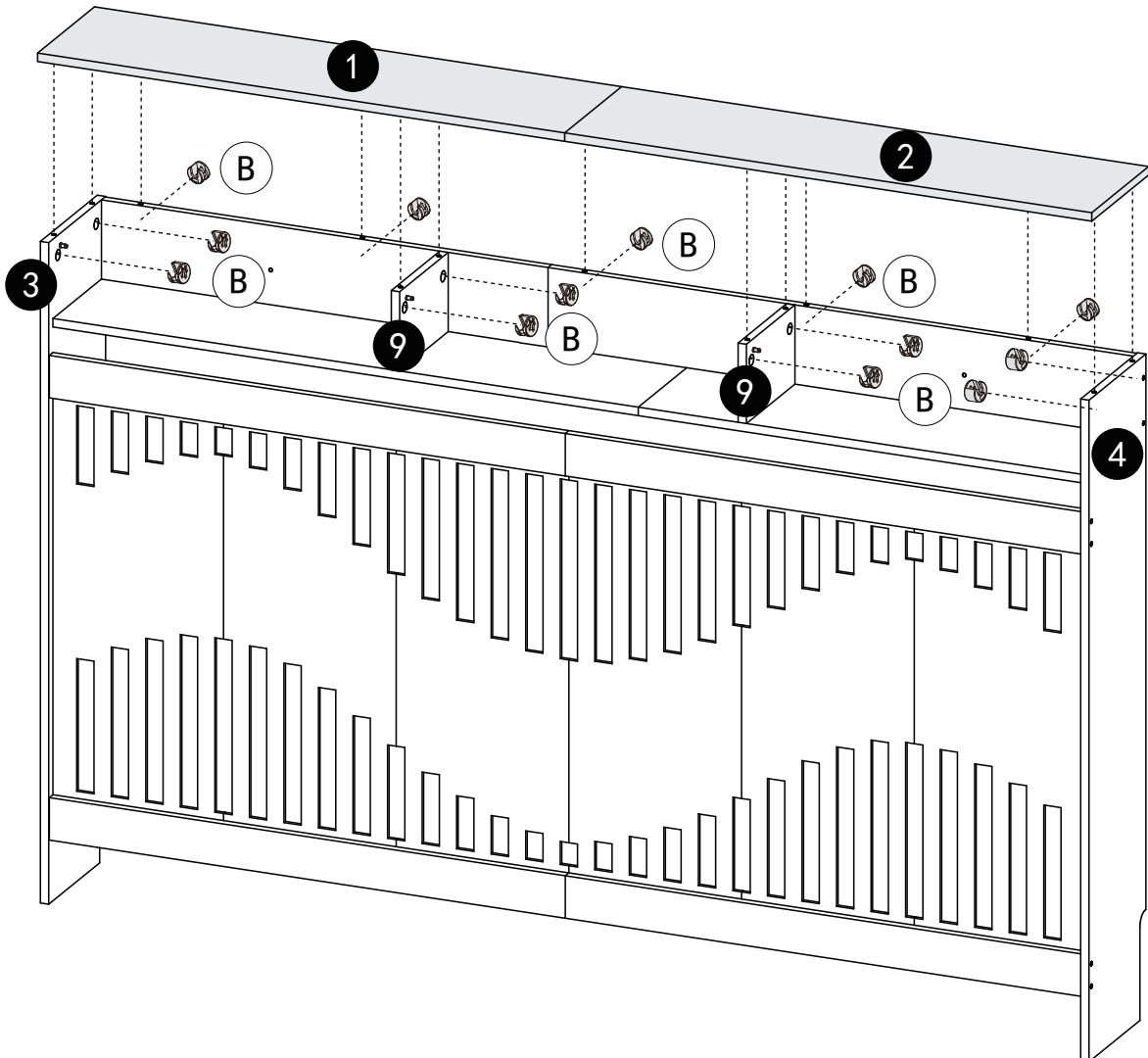
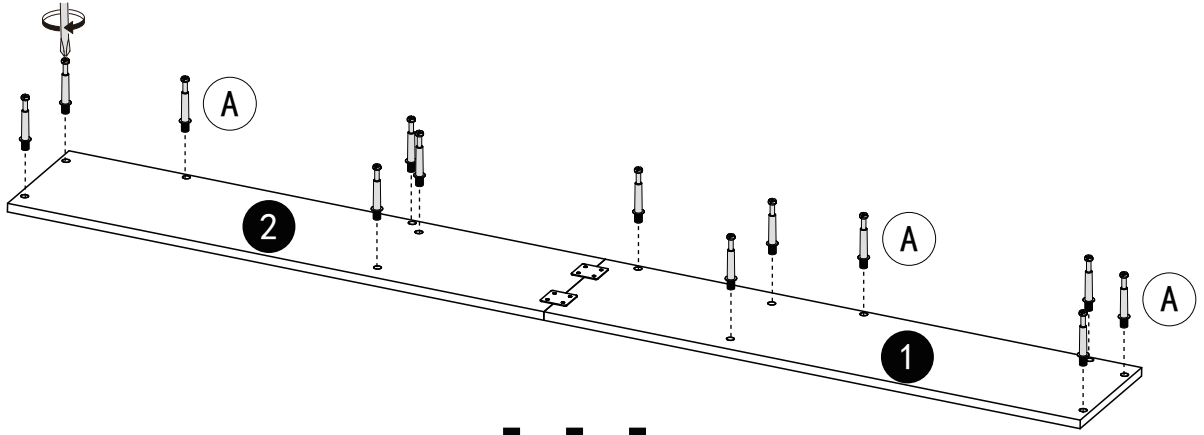
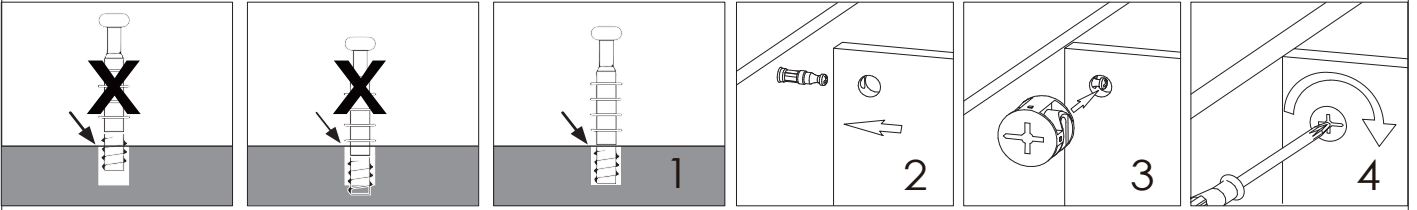
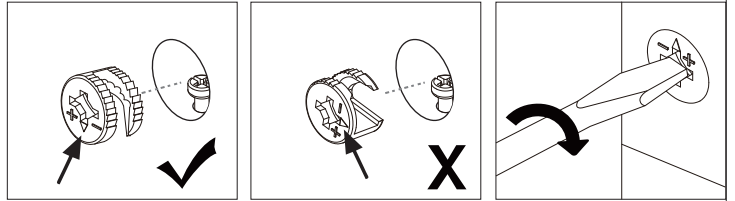
STEP 9

YOU WILL NEED

A x13

B x13

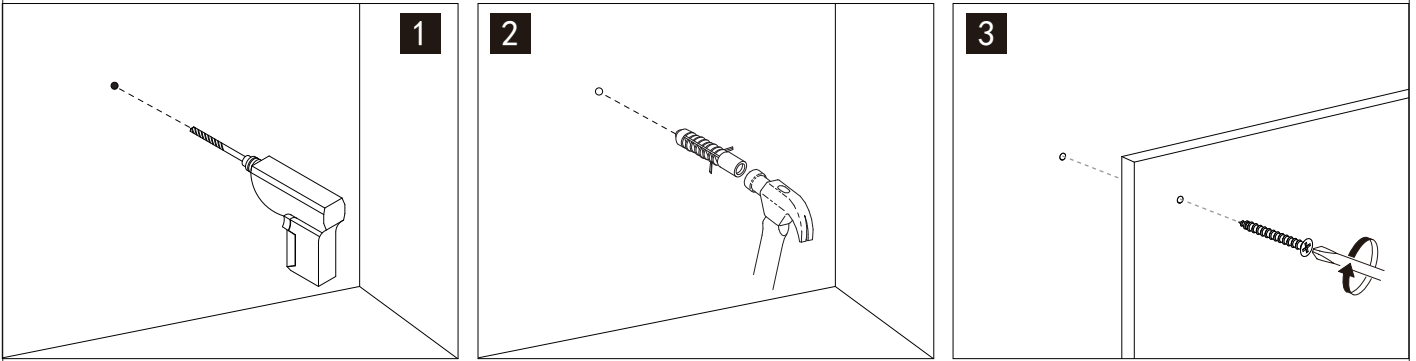
Installation method of three in one rod and buckle



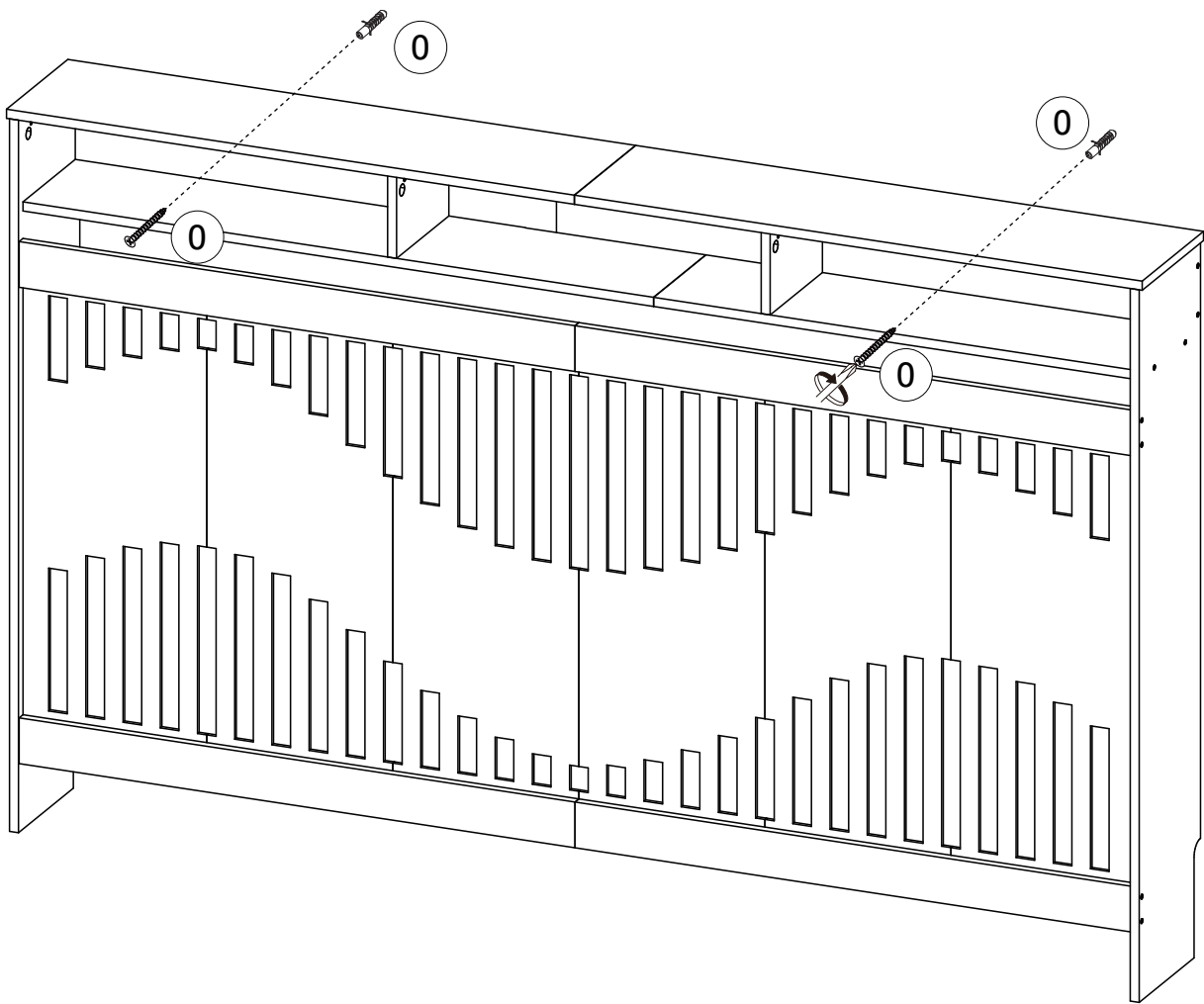
STEP 10

YOU WILL NEED

○ x2



After drilling holes in the wall, insert the expansion bolts. Then, use the expansion wires to firmly connect the furniture to the wall, effectively preventing it from tipping over.



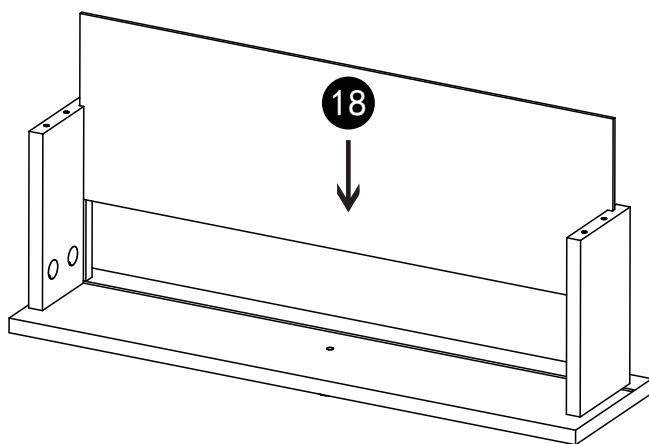
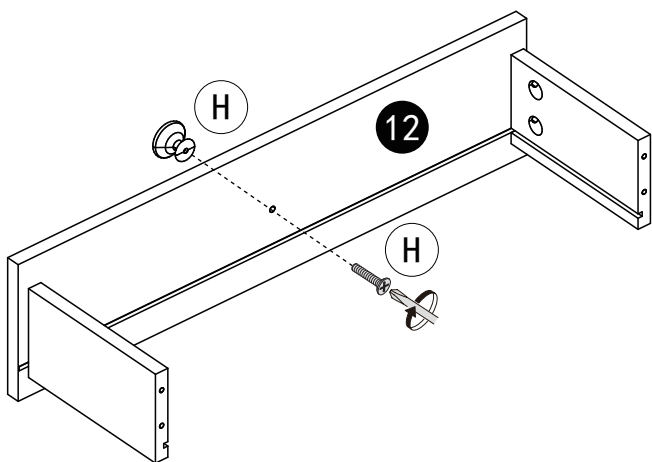
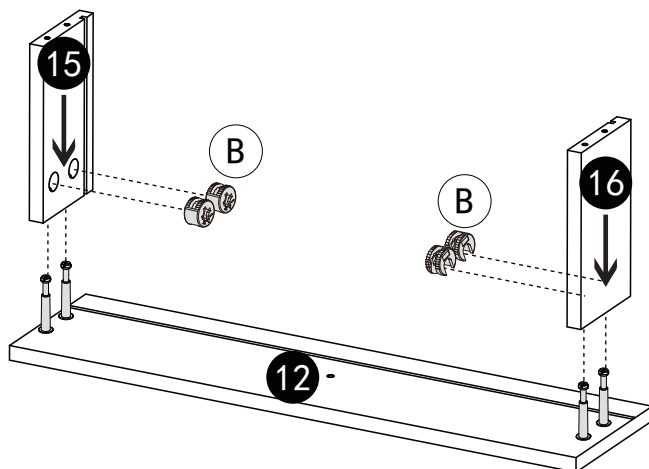
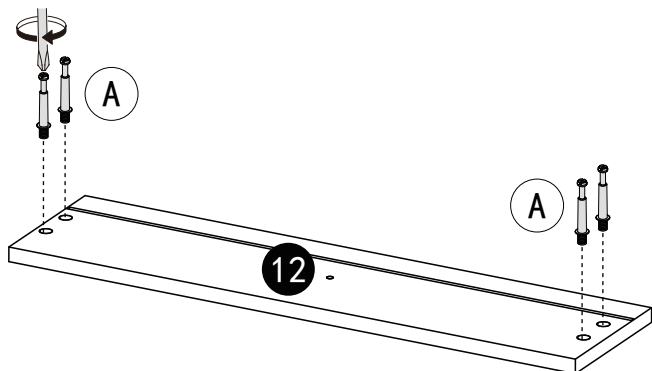
STEP 11

YOU WILL NEED

A x4

B x4

H x1

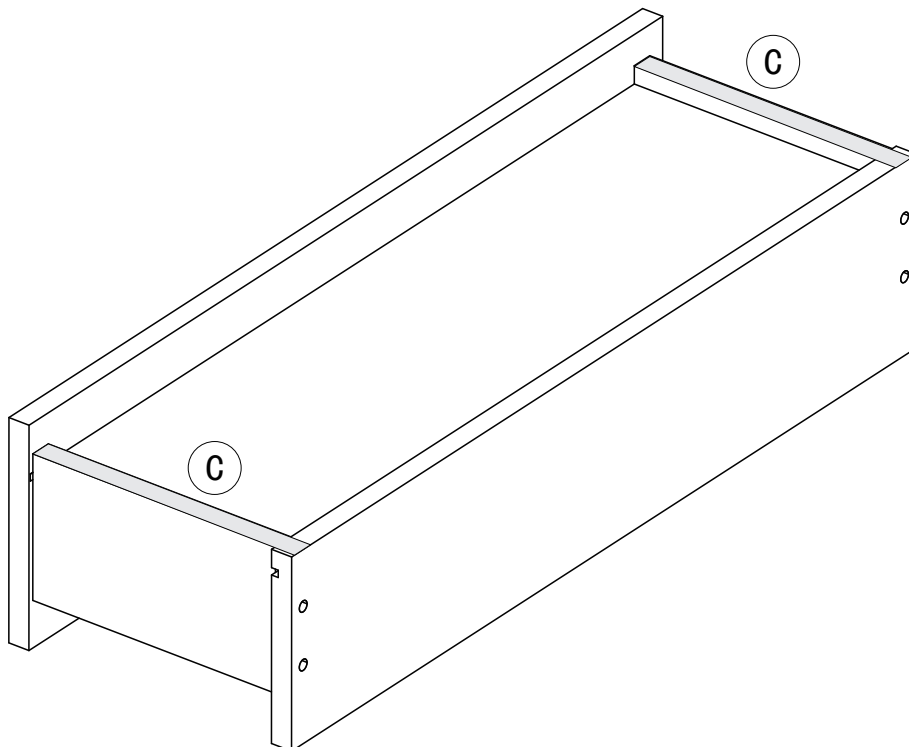
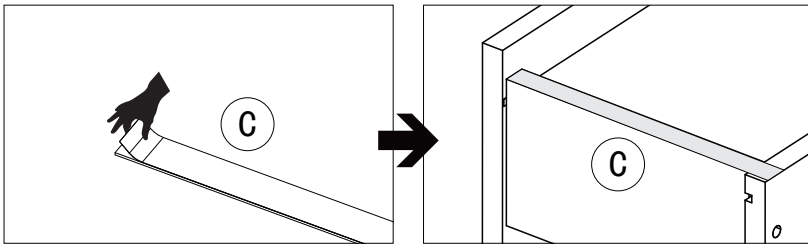
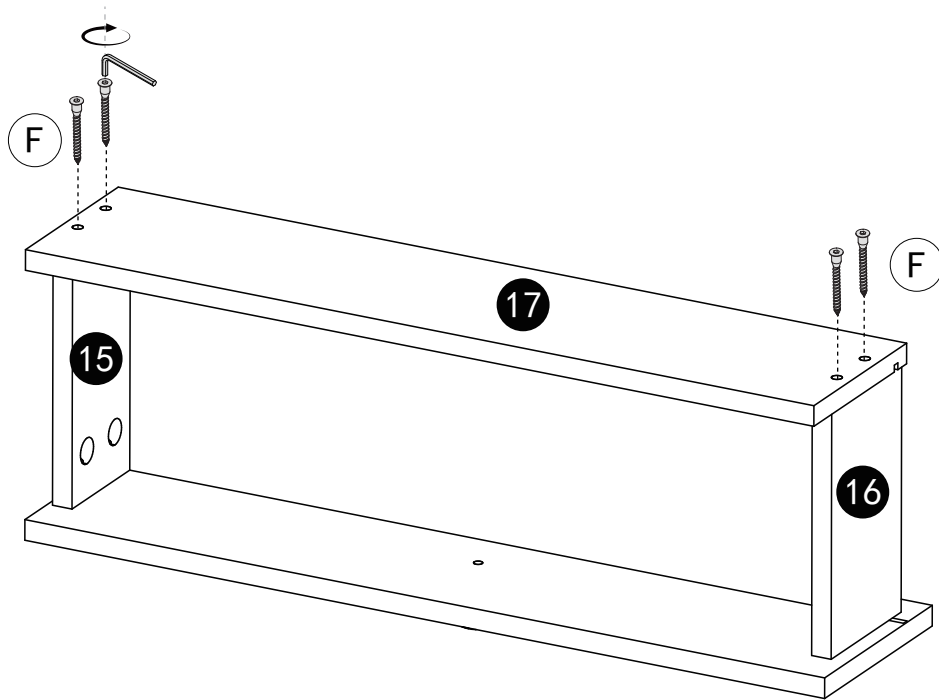


STEP 12

YOU WILL NEED

F x4

C x2



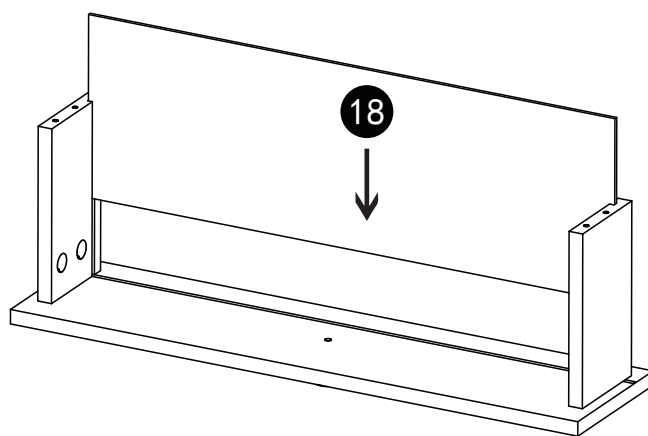
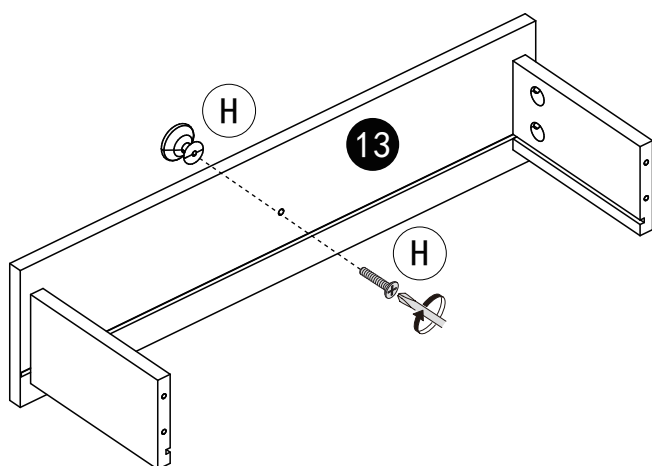
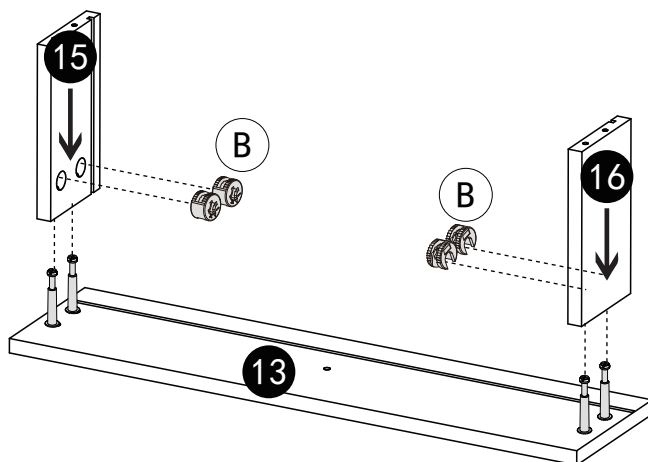
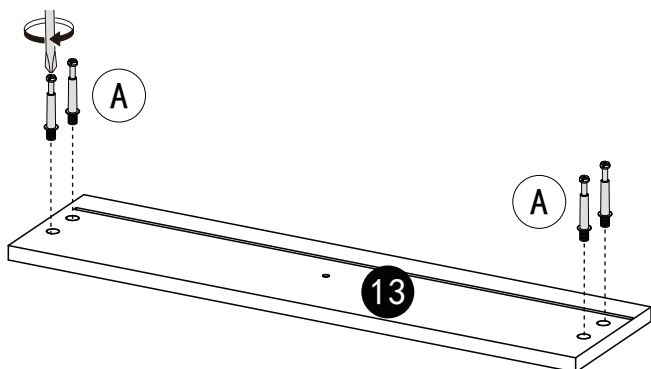
STEP 13

YOU WILL NEED

A x4

B x4

H x1

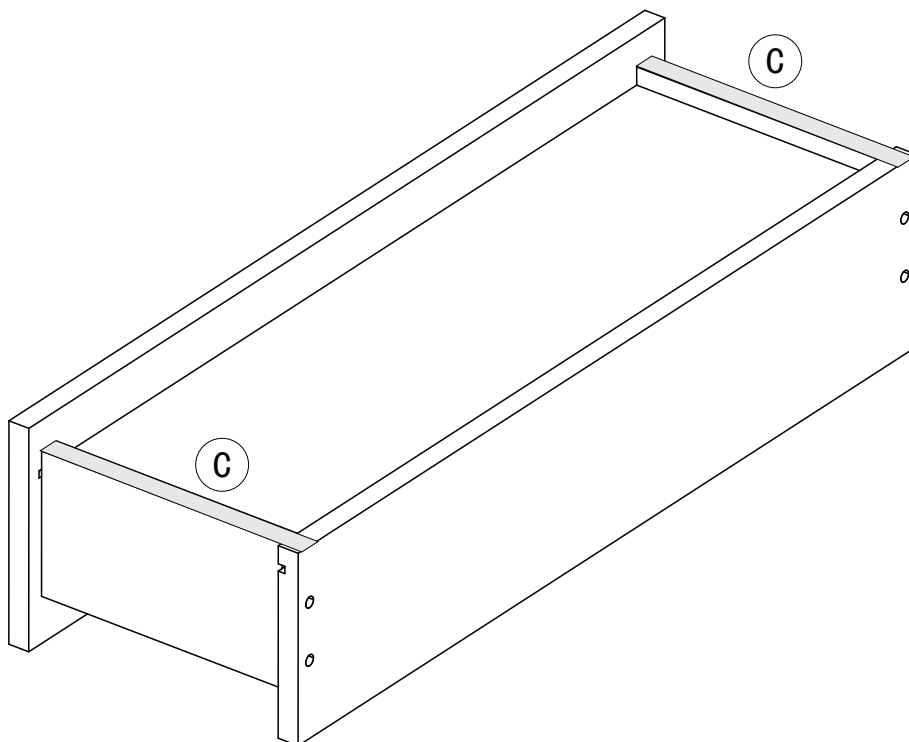
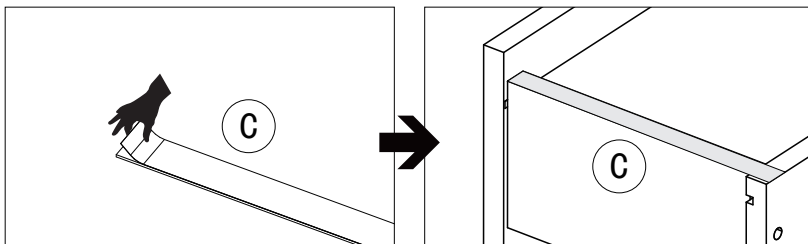
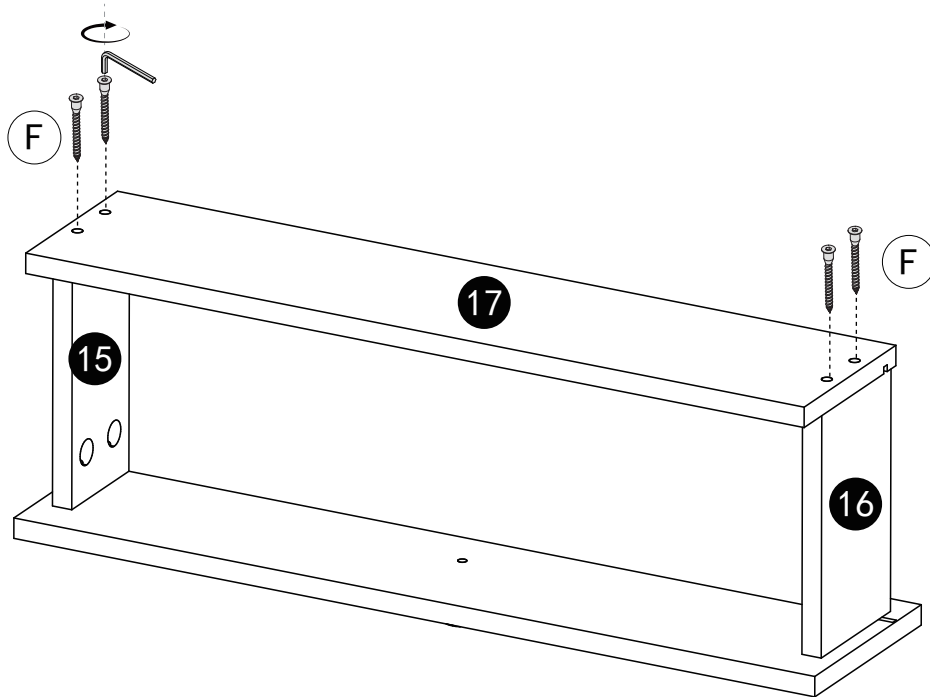


STEP 14

YOU WILL NEED

F x4

C x2



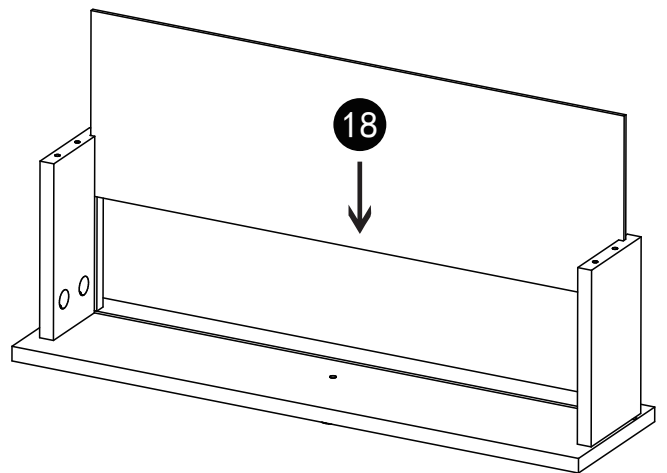
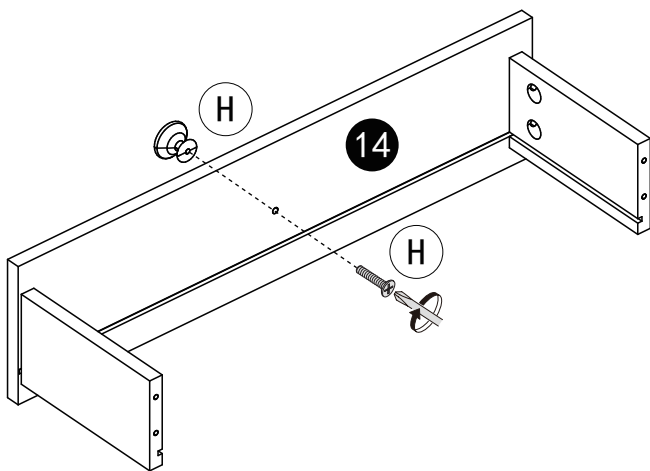
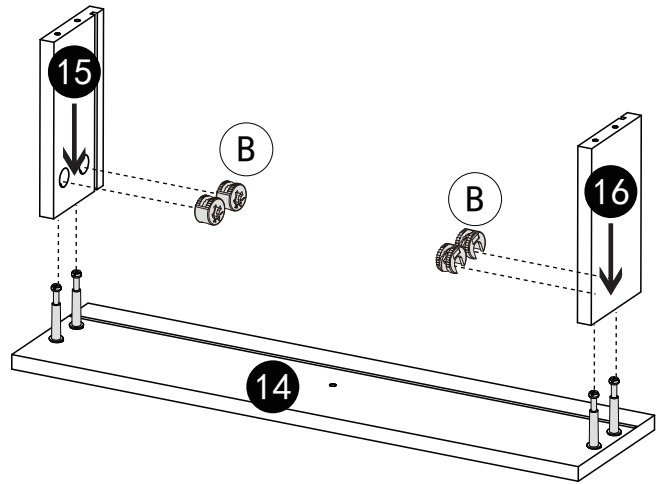
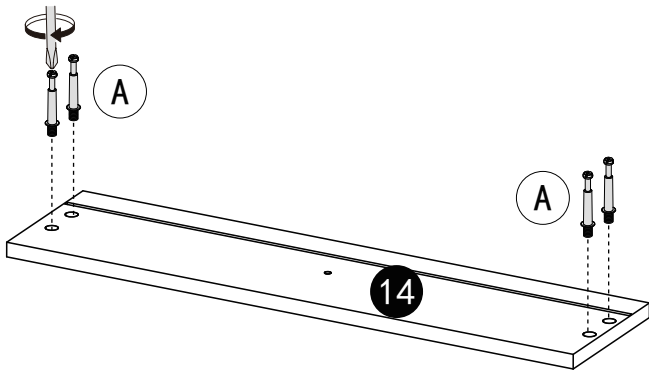
STEP 15

YOU WILL NEED

A x4

B x4

H x1

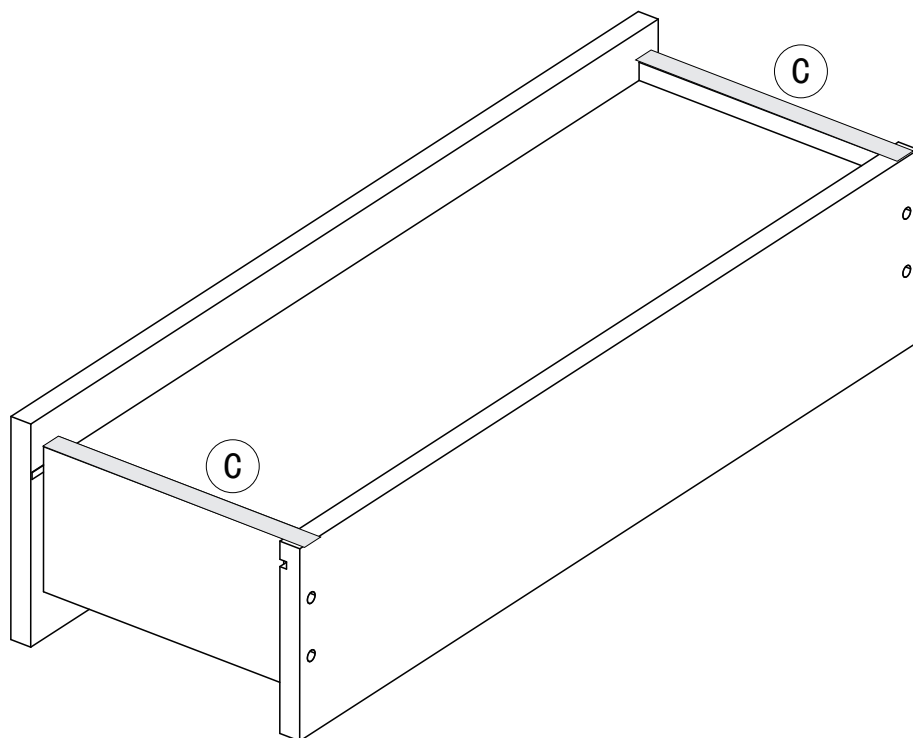
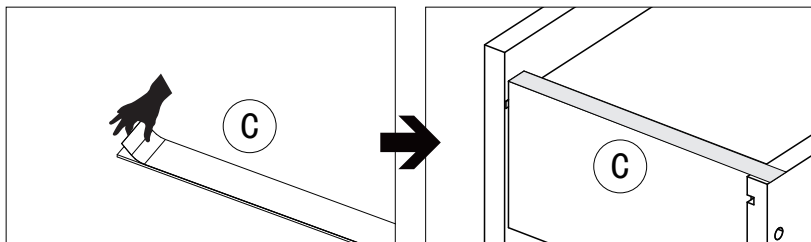
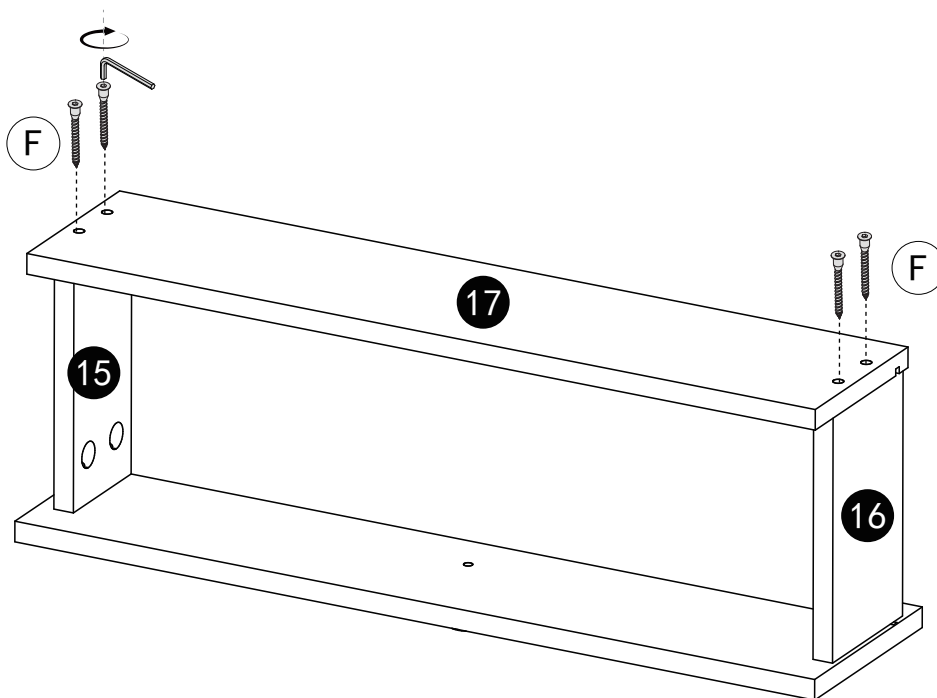


STEP 16

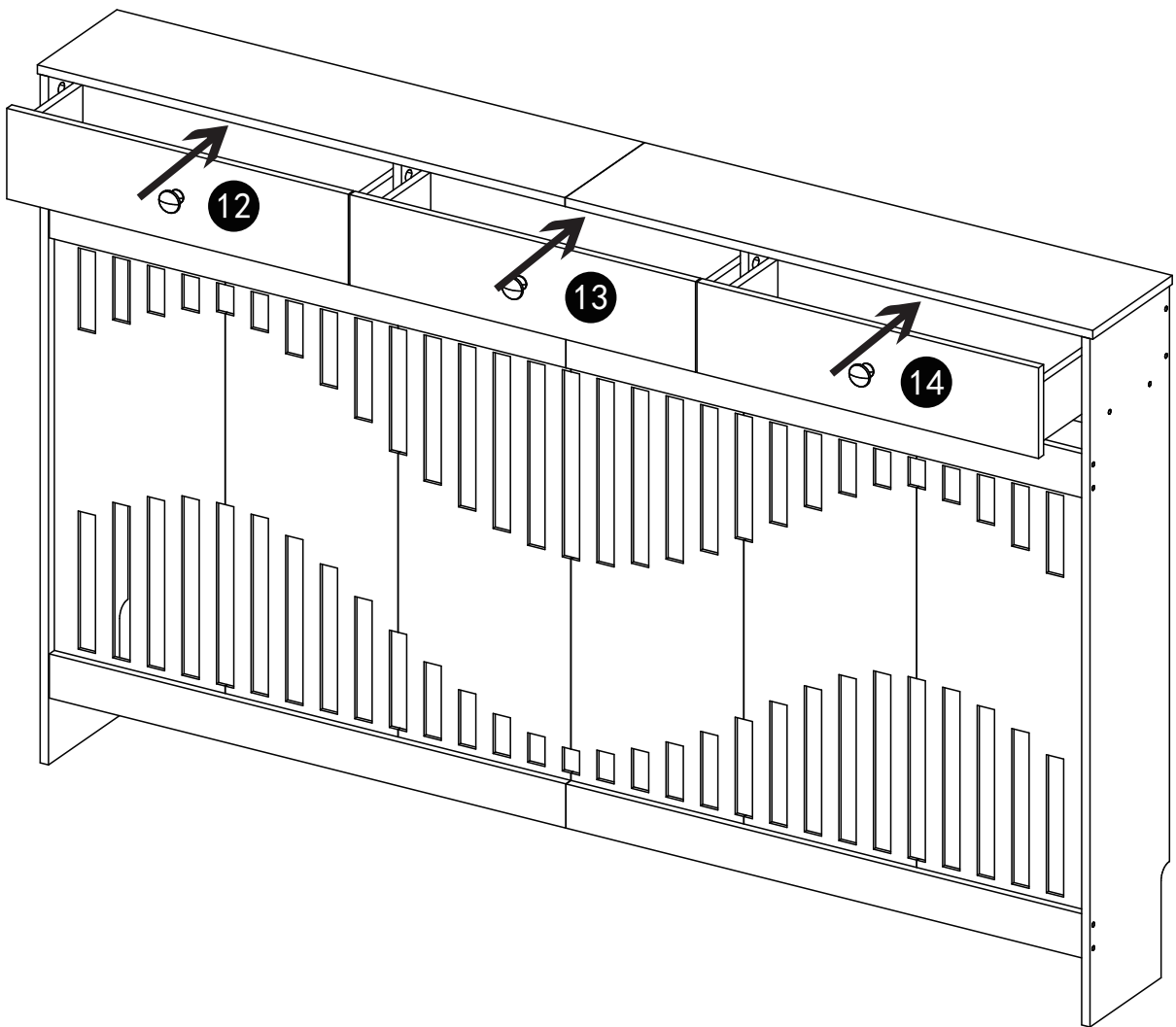
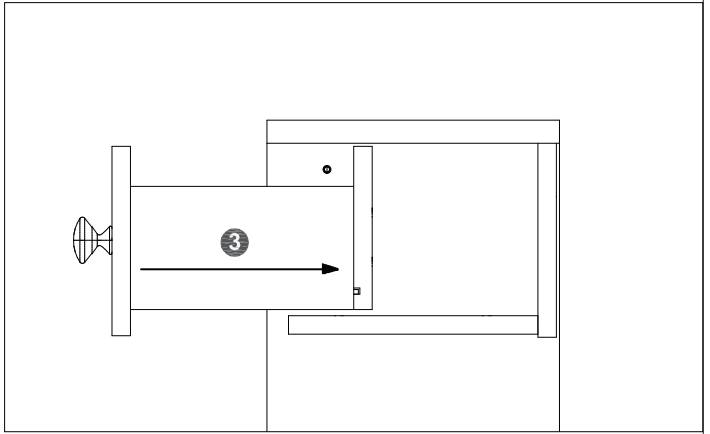
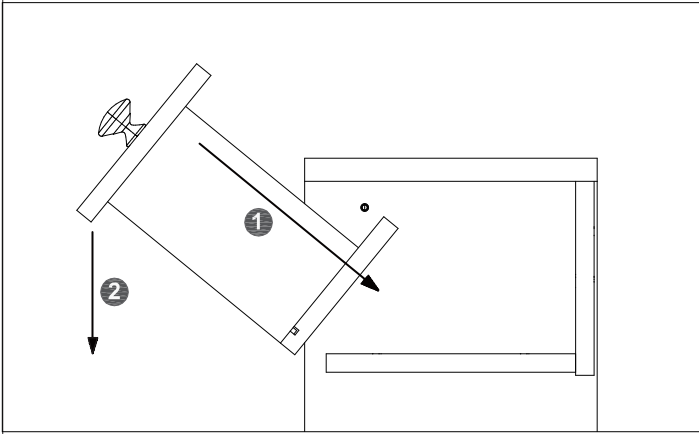
YOU WILL NEED

F x4

C x2



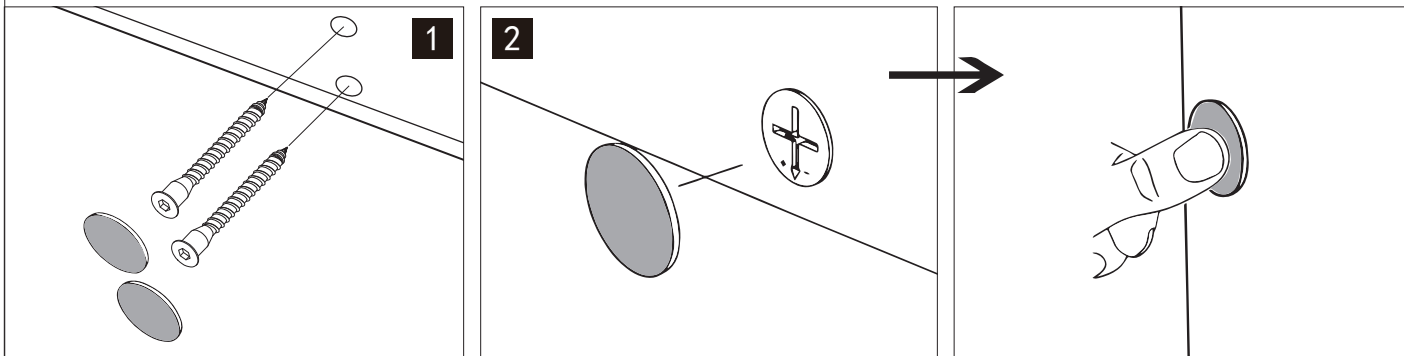
STEP 17



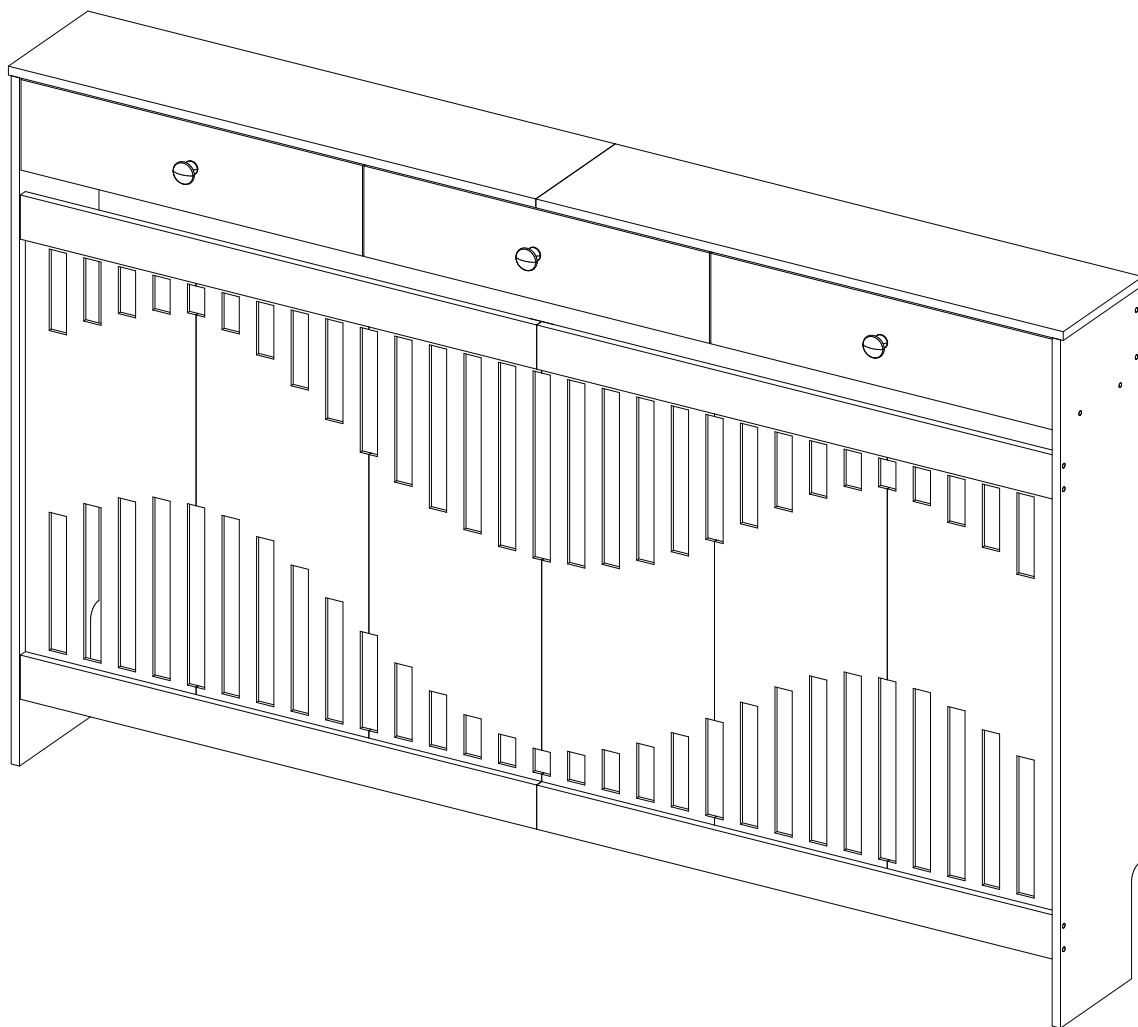
STEP 18

YOU WILL NEED

L x36



Add L fittings to all exposed holes on the front of the product



NOTICE

EN

1. Please do not exceed the weight limits of this item.
2. Firmly secure all bolts, screws and knobs before use.
3. Reconfirm that all bolts, screws and knobs are secure after every 90 days.
4. Fasten screws loosely during initial assembly. Do not tighten the screws firmly until the item is assembled completely.
5. Do not use or store this item in the proximity of an open flame or flammable chemicals.
6. If any part is missing, broken, damaged, or worn, stop using this product until repairs are made and or factory replacement parts are installed.
7. Do not use this item in any manner inconsistent with the manufacturer's instruction as this could void the product's warranty.

FR

1. Veuillez ne pas dépasser le poids recommandé.
2. Veuillez vous assurer que toutes les vis et écrous sont bien serrés avant la première utilisation.
3. Veuillez resserrer régulièrement toutes les vis et écrous pour prolonger la durée de vie du produit.
4. Lors de la première installation, veuillez ne pas serrer complètement les vis et les écrous. Après avoir terminé toutes les étapes d'installation, veuillez serrer toutes les vis et écrous uniformément.
5. N'utilisez pas le produit à proximité de flammes nues ou de matériaux inflammables.
6. Si vous constatez que les accessoires sont perdants, endommagés ou vieillis, veuillez cesser immédiatement d'utiliser le produit jusqu'à ce que la réparation soit terminée ou que les accessoires d'origine soient utilisés pour terminer le remplacement.
7. Veuillez utiliser le produit conformément aux instructions du fabricant, sinon cela affectera la durée de vie du produit et invalidera la garantie du produit.

DE

1. Bitte überschreiten Sie nicht das empfohlene Gewicht.
2. Bitte stellen Sie vor dem ersten Gebrauch sicher, dass alle Schrauben und Muttern fest angezogen sind.
3. Ziehen Sie alle Schrauben und Muttern regelmäßig wieder an, um die Lebensdauer des Produkts zu verlängern.
4. Bitte ziehen Sie die Schrauben und Muttern während der Erstinstallation nicht vollständig an. Ziehen Sie nach Abschluss aller Installationsschritte alle Schrauben und Muttern gleichmäßig an.
5. Verwenden Sie das Produkt nicht in der Nähe von offenen Flammen oder brennbaren Materialien.
6. Wenn Sie feststellen, dass das Zubehör fehlt, beschädigt ist oder altert, stellen Sie die Verwendung des Produkts sofort ein, bis die Reparatur abgeschlossen ist oder das Originalzubehör zum Abschluss des Austauschs verwendet wird.
7. Bitte verwenden Sie das Produkt gemäß den Anweisungen des Herstellers. Andernfalls wird die Lebensdauer des Produkts beeinträchtigt und die Produktgarantie erlischt.

NOTICE

ES

1. No utilice más del peso recomendado.
2. Asegúrese de que todos los tornillos y tuercas estén completamente apretados antes del uso inicial.
3. Vuelva a apretar todos los tornillos y tuercas regularmente para prolongar la vida útil del producto.
4. No apriete completamente los tornillos y tuercas durante la instalación inicial, y apriete todos los tornillos y tuercas uniformemente después de que se completen todos los pasos de instalación.
5. No utilice el producto cerca de llamas abiertas o materiales inflamables.
6. Si se encuentra que falta algún accesorio, está dañado o envejece, deje de usar el producto inmediatamente hasta que se complete la reparación o se realice el reemplazo con la pieza original.
7. Siga las instrucciones del fabricante para utilizar el producto, de lo contrario afectará a la vida útil del producto y invalidará la garantía del producto.

IT

1. Si prega di non superare il peso consigliato.
2. Assicurarsi che viti e dadi (tutti) siano completamente serrati prima dell'utilizzo.
3. Verificare regolarmente (ogni 90 giorni) che viti e dadi siano ben serrati.
4. Si prega di non serrare completamente viti e dadi durante l'installazione iniziale. Solamente dopo aver completato tutti i passaggi di installazione, serrare viti e dadi in modo uniforme.
5. Non utilizzare il prodotto vicino a fiamme libere o materiali infiammabili.
6. Se qualche pezzo risulta danneggiato, rotto, consumato o mancante, fermare immediatamente l'utilizzo del prodotto e procedere alla relativa sostituzione con ricambi originali.
7. Per non compromettere la durata di vita del prodotto e/o perdere il diritto alla garanzia, utilizzare il prodotto seguendo le istruzioni del produttore.



OCEAN SUPPORT LTD
(E-mail: Info@topouxun.com) Amber, Office 119,
Luminous House 300 South Row, Milton Keynes, MK9 2FR