

IMPORTANT NOTE

Carefully remove all the parts from the carton and put them individually on a soft cloth to prevent scratches or other damages occurring to the wood parts.

We have taken great care in the design of this product and request that you carefully and strictly follow our assembly instructions to ensure a completed product as it was designed.



Part List

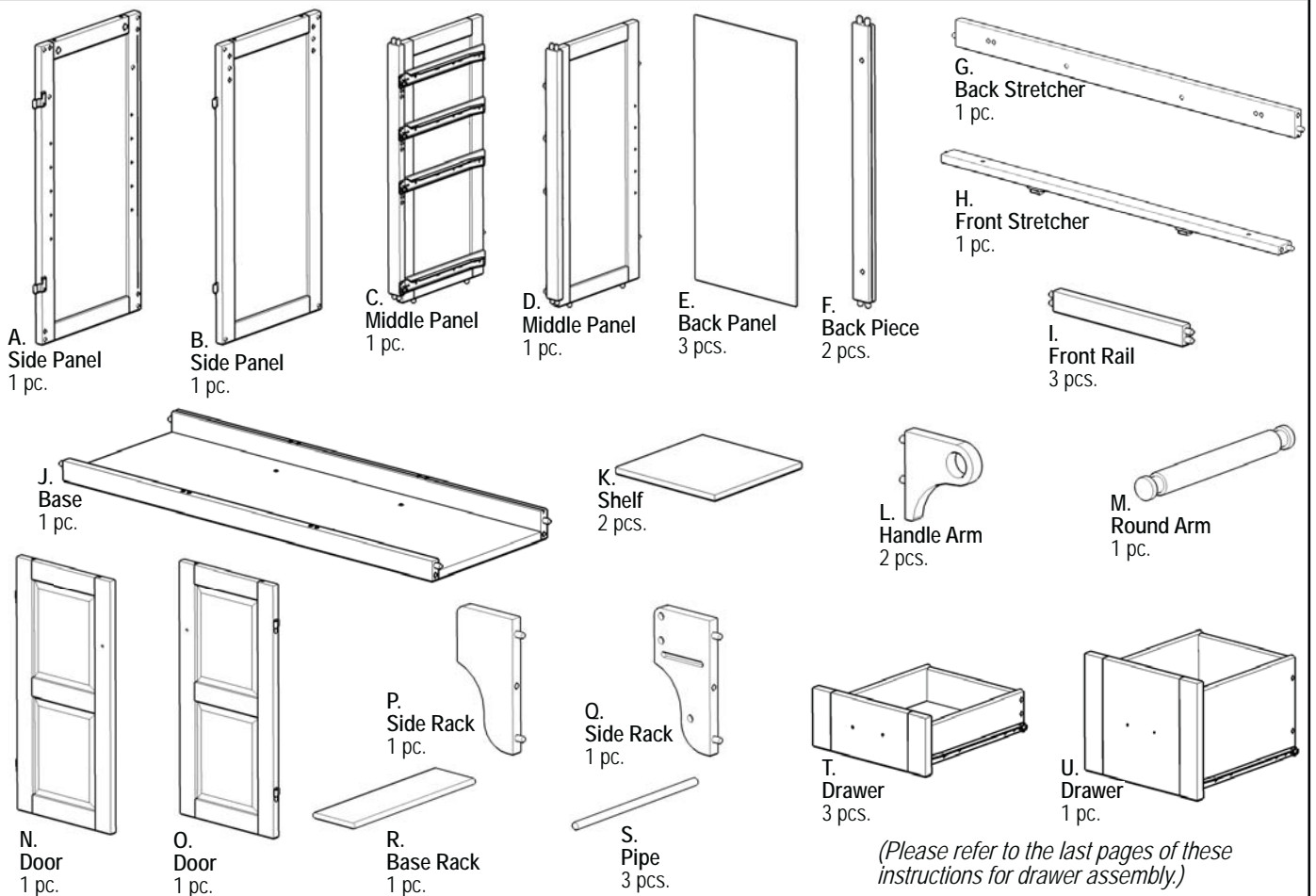

Hardware List



Tools required for assembly : Phillips screwdriver

IMPORTANT

- * Do not tighten up all the screws and bolts until each part is properly assembled.
- * You should keep Hex Wrench in a safe place as you may need to tighten up the Head Cap Bolts in the future.
- * Use a soft cloth between these parts and the floor.

STEP 1

Attach 4X Casters to Base (J) with Wood Screws for Caster, with the Locking Casters at the front as indicated by 'Arrow' sticker. (see Figure 1)

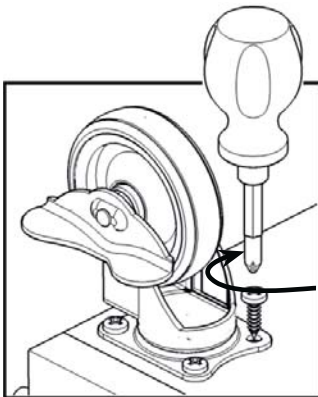
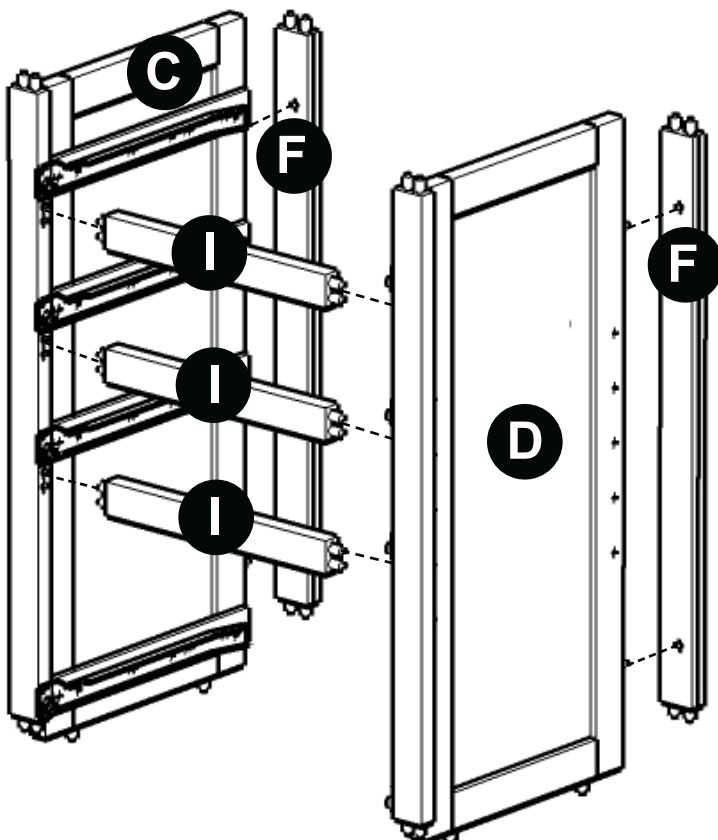
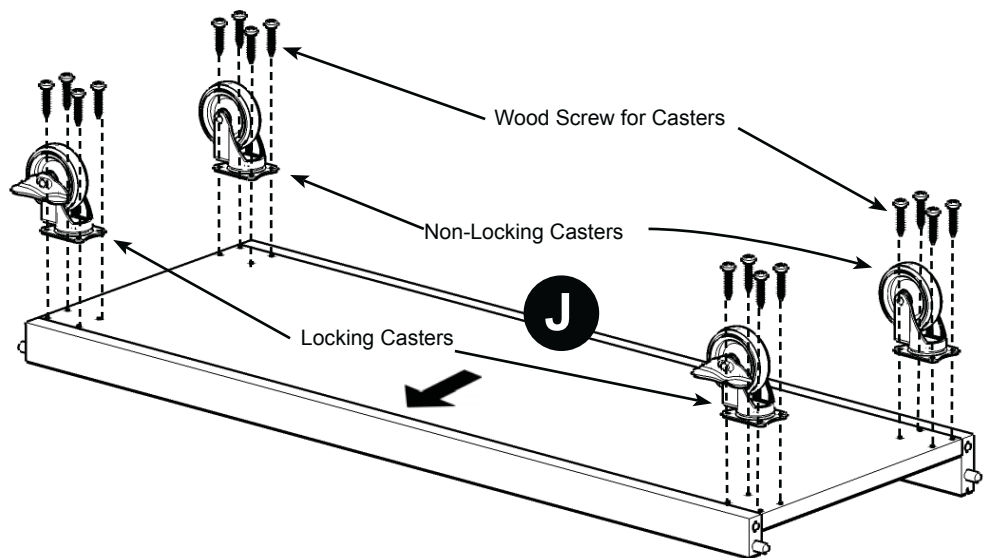

Figure 1



STEP 2

Attach Back Pieces (F) to Middle Panels (C) and (D).

Attach Front Rails (I) to Middle Panels (C) and (D).

STEP 3

Attach unit to Base (J).

Attach Side Panel (A) to unit with Head Cap Bolts. (see Figure 2)

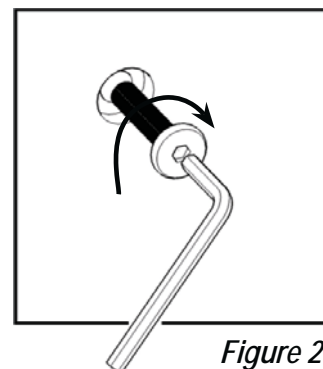
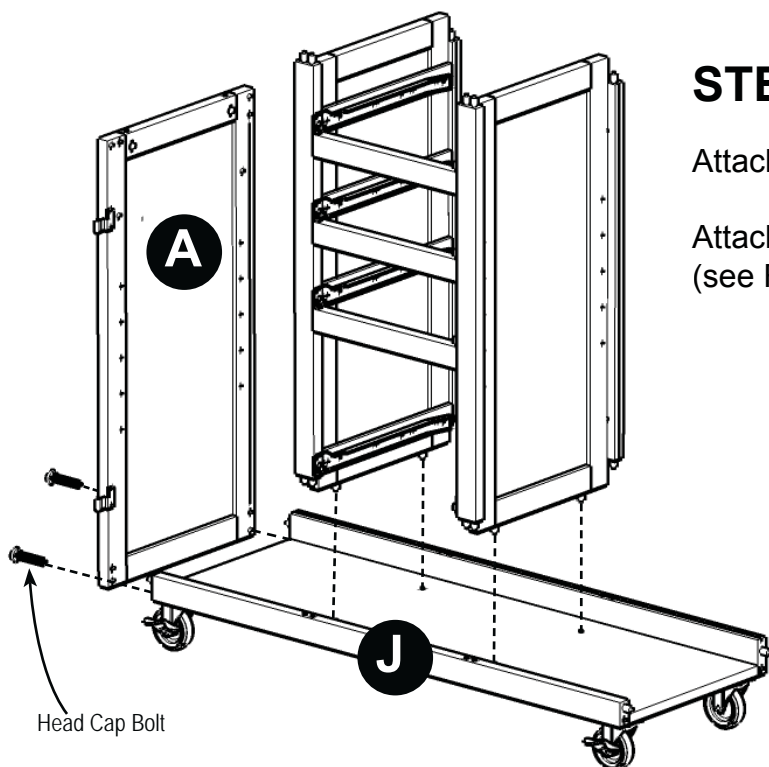

STEP 4

Slide Back Panels (E) into the unit.

Attach Back Stretcher (G) and Front Piece (H) to the unit with Head Cap Bolts.

Attach Side Panel (B) with Head Cap Bolts.

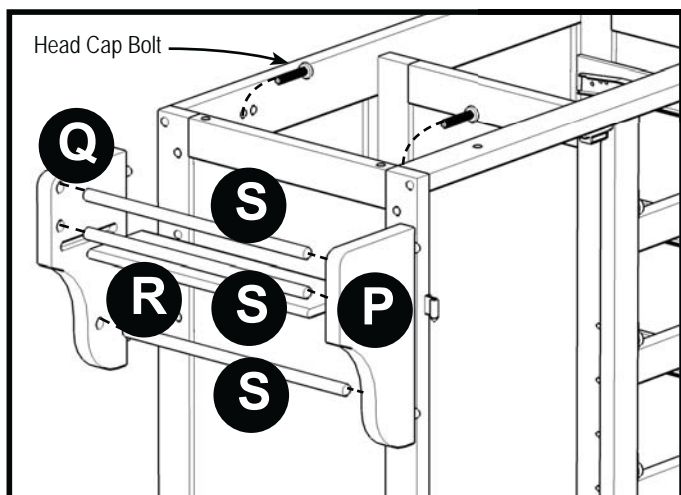
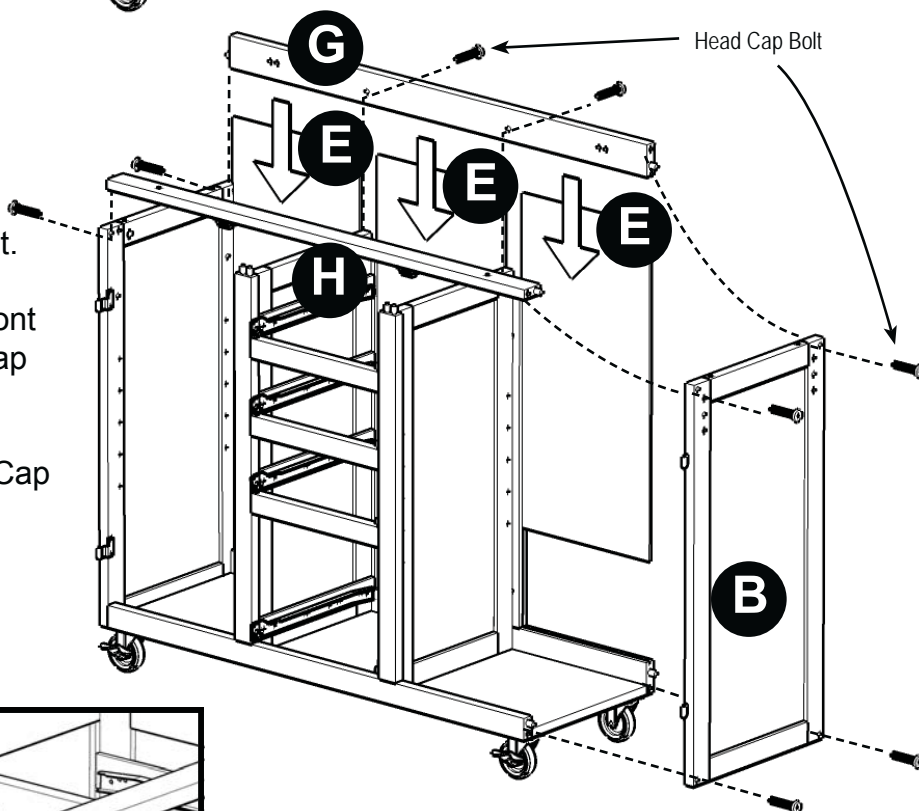

STEP 5

Attach Side Rack (Q) to the unit with Head Cap Bolts.

Slide Base Rack (R) and Pipes (S) to Side Rack (Q).

Attach Side Rack (P) to unit with Head Cap Bolts.

STEP 6

Assemble Handle Arms (L) to Side Panel (B) with Head Cap Bolts.

Slide Round Arm (M) into place.

Head Cap Bolt

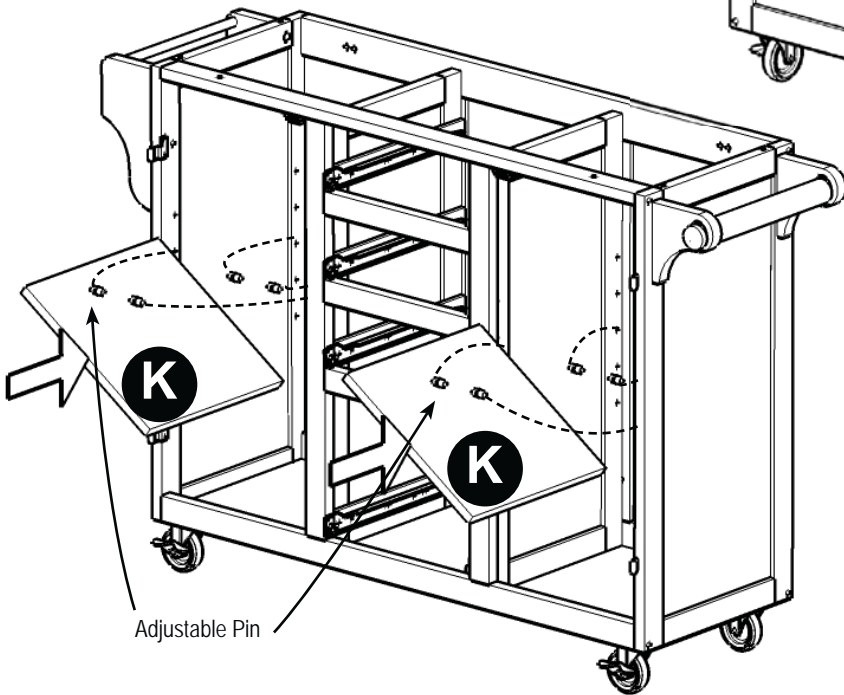
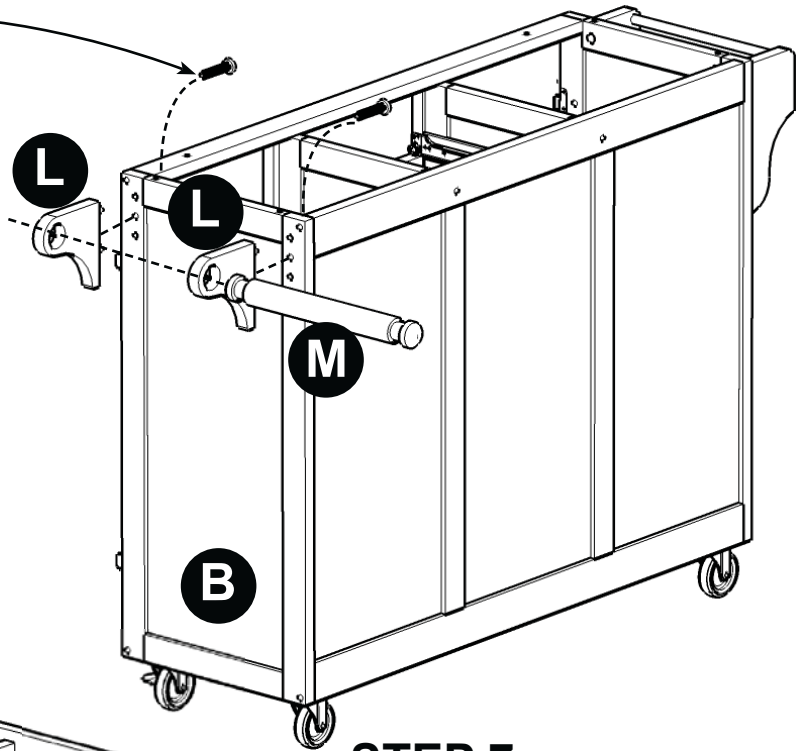

STEP 7

Insert Adjustable Pins into side panels and middle panels at the desired level and slide Shelves (K) into place.

Adjustable Pin

Wood Plug

STEP 8

Cover all holes with Wood Plugs. (see Figure 3)

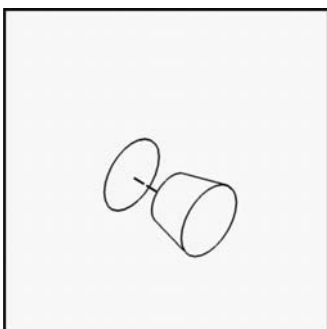
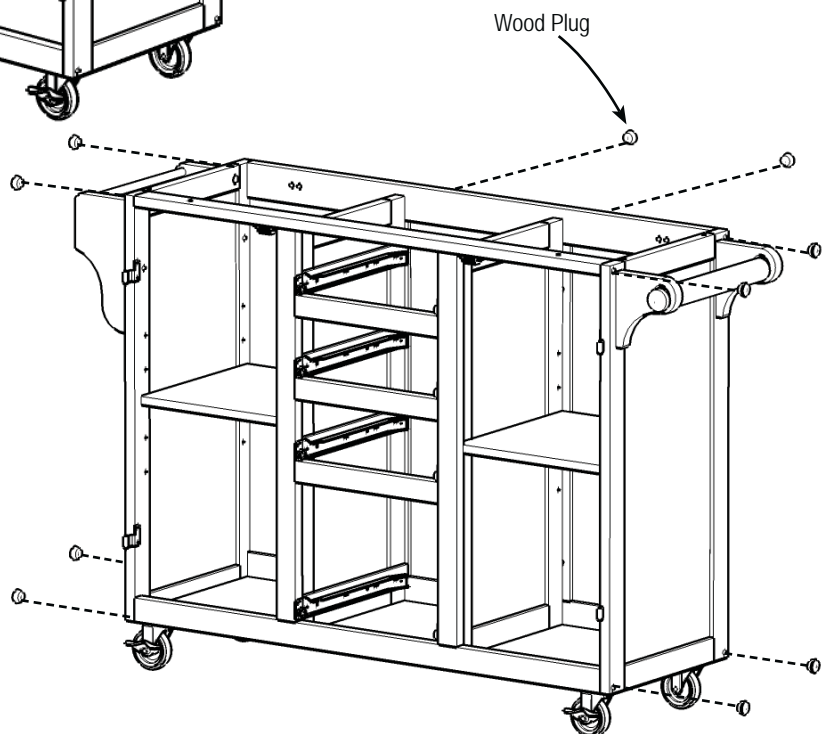

Figure 3

Wood Plug



Drawer (T)

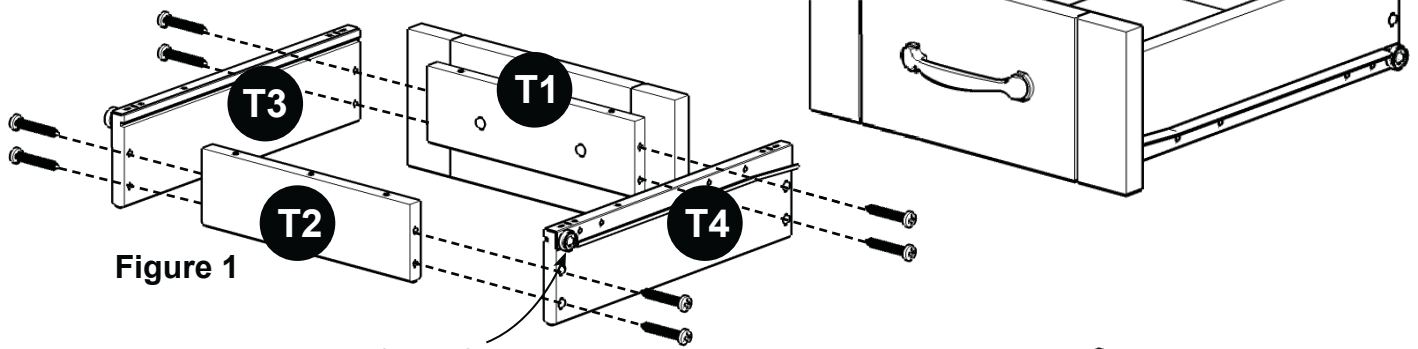

Figure 1

MAKE SURE ROLLER IS ON THE BACK

STEP 1

Attach T1 to T3 and T4, using a Phillips screwdriver and long wood screws (4X), tighten halfway.

Attach T2 to T3 and T4 using long wood screws (4X), tighten halfway. (see Figure 1)

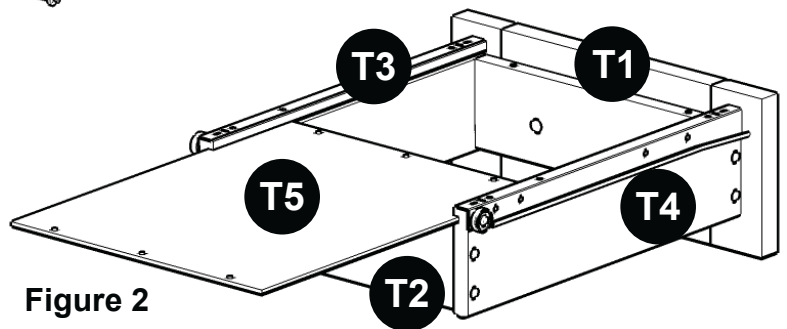

Figure 2

STEP 2

Slide T5 into the grooves in T3 and T4. Push T5 all the way forward so it meets T1. (see Figure 2)

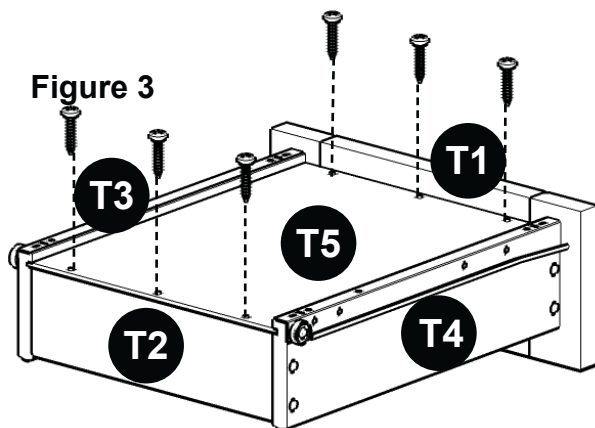

Figure 3

STEP 3

Insert short wood screws (6X) into the pre-drilled holes in T5 and tighten. (see Figure 3)

STEP 4

Assemble Pull Handle with Machine Screws. (see Figure 4)

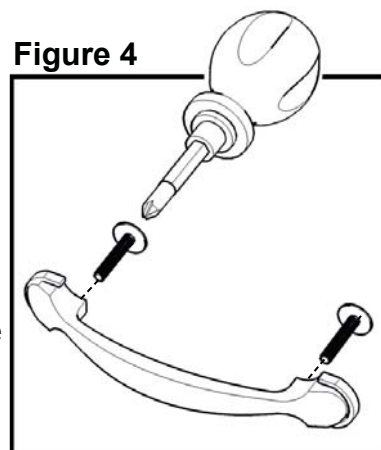
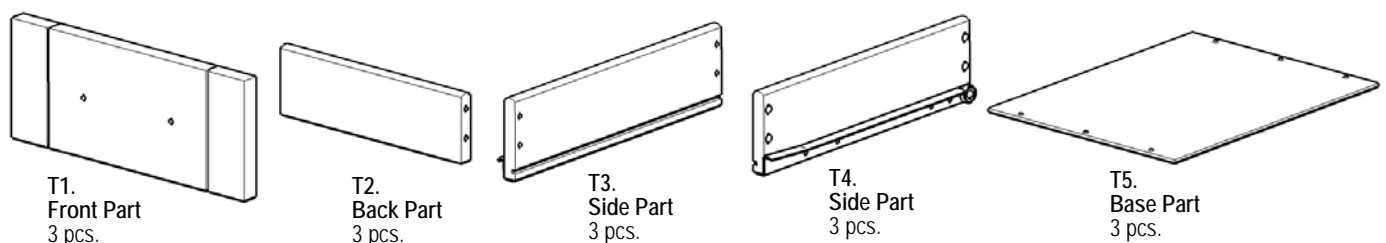

Figure 4

Tighten all screws used in drawer assembly.

Part List



T1.
Front Part
3 pcs.

T2.
Back Part
3 pcs.

T3.
Side Part
3 pcs.

T4.
Side Part
3 pcs.

T5.
Base Part
3 pcs.

Drawer (U)

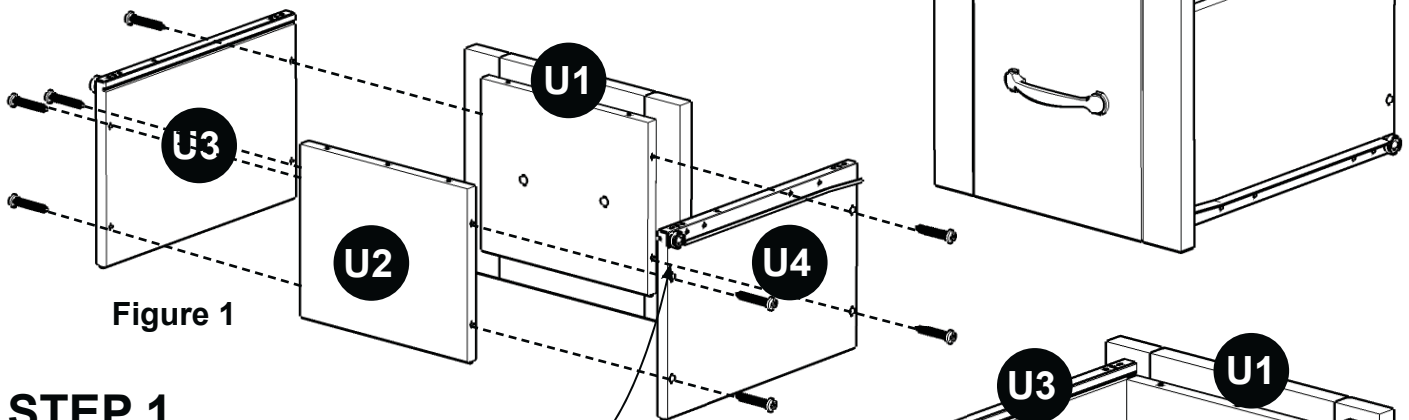

Figure 1

STEP 1

Attach U1 to U3 and U4, using a Phillips screwdriver and long wood screws (4X), tighten halfway.

Attach U2 to U3 and U4 using long wood screws (4X), tighten halfway. (see Figure 1)

MAKE SURE ROLLER IS ON THE BACK

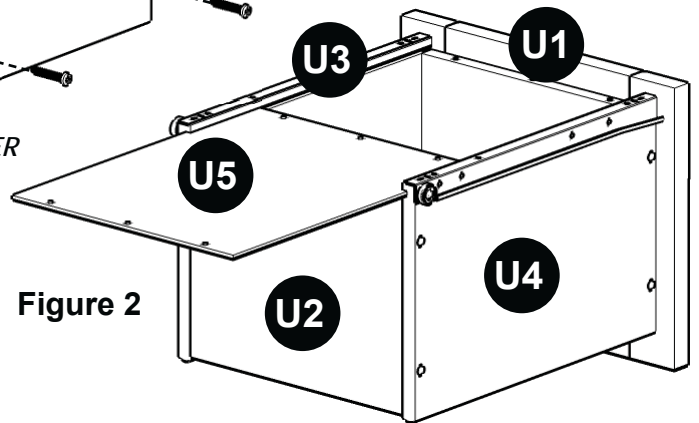
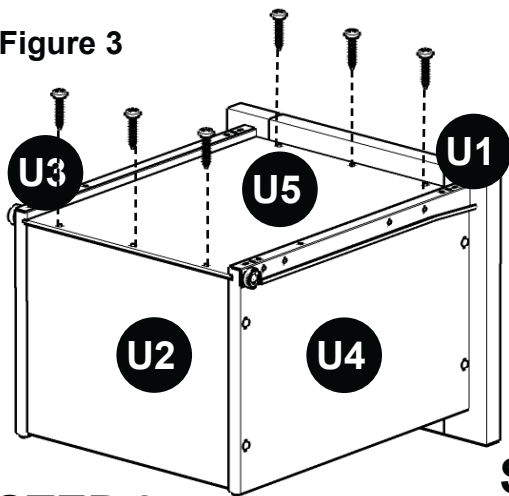

Figure 2

STEP 2

Slide U5 into the grooves in U3 and U4. Push U5 all the way forward so it meets U1. (see Figure 2)

Figure 3



STEP 3

Insert short wood screws (6X) into the pre-drilled holes in U5 and tighten. (see Figure 3)

STEP 4

Assemble Pull Handle with Machine Screws. (see Figure 4)

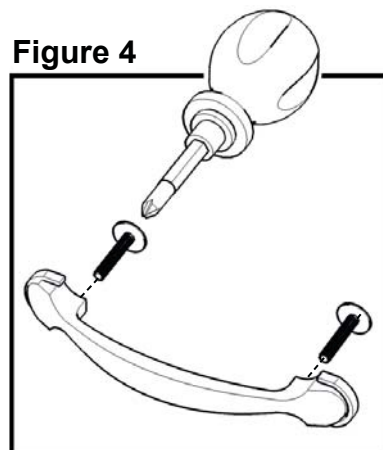
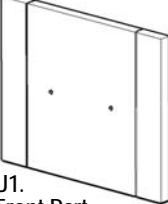
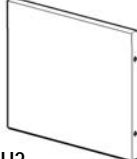
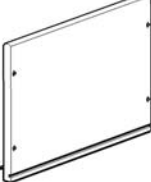
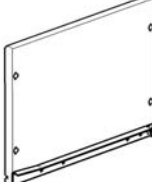



Figure 4

Tighten all screws used in drawer assembly.

Part List

				
U1. Front Part 1 pc.	U2. Back Part 1 pc.	U3. Side Part 1 pc.	U4. Side Part 1 pc.	U5. Base Part 1 pc.