

ASSEMBLY INSTRUCTIONS



ACCENT TABLE

ASSEMBLY INSTRUCTIONS

ASSEMBLY TIPS:

1. Remove hardware from box and sort by size.
2. Please check to see that all hardware and parts are present prior to start of assembly.
3. Please follow attached instructions in the same sequence as numbered to assure fast & easy assembly.





WARNING!

1. Don't attempt to repair or modify parts that are broken or defective. Please contact the store immediately.
2. This product is for home use only and not intended for commercial establishments.

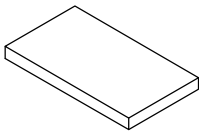

ASSEMBLY TIME 25 MINUTES

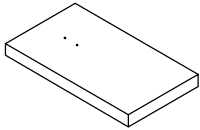
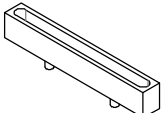
PARTS IDENTIFICATION

A	TOP PANEL		1PC
B	BACK GLASS		1PC
C	SUPPORT GLASS		1PC
D	BOTTOM PANEL		1PC
E	ACRYLIC GLASS GROOVE		1PC

ASSEMBLY INSTRUCTIONS

HARDWARE IDENTIFICATION

1	LONG BOLT (1/4" x 1-1/2" SR)		4PCS
2	SHORT BOLT (1/4" x 1-1/4" SR)		2PCS
3	NUT (1/4" x 5/8" SR)		2PCS
4	CYLINDER NUT (ϕ 35mm)		4PCS
5	LARGE PLASTIC WASHER (ϕ 32mm)		8PCS
6	SMALL PLASTIC WASHER (ϕ 19mm)		2PCS
7	WASHER (ϕ 16mm)		4PCS
8	NUT WASHER (5/16")		2PCS
9	FOOT PIN (ϕ 18 x 17mm)		4PCS
10	ALLEN WRENCH (4mm)		2PCS

ASSEMBLY INSTRUCTIONS

STEP 1 Do not tighten until each step is completed or instructed.

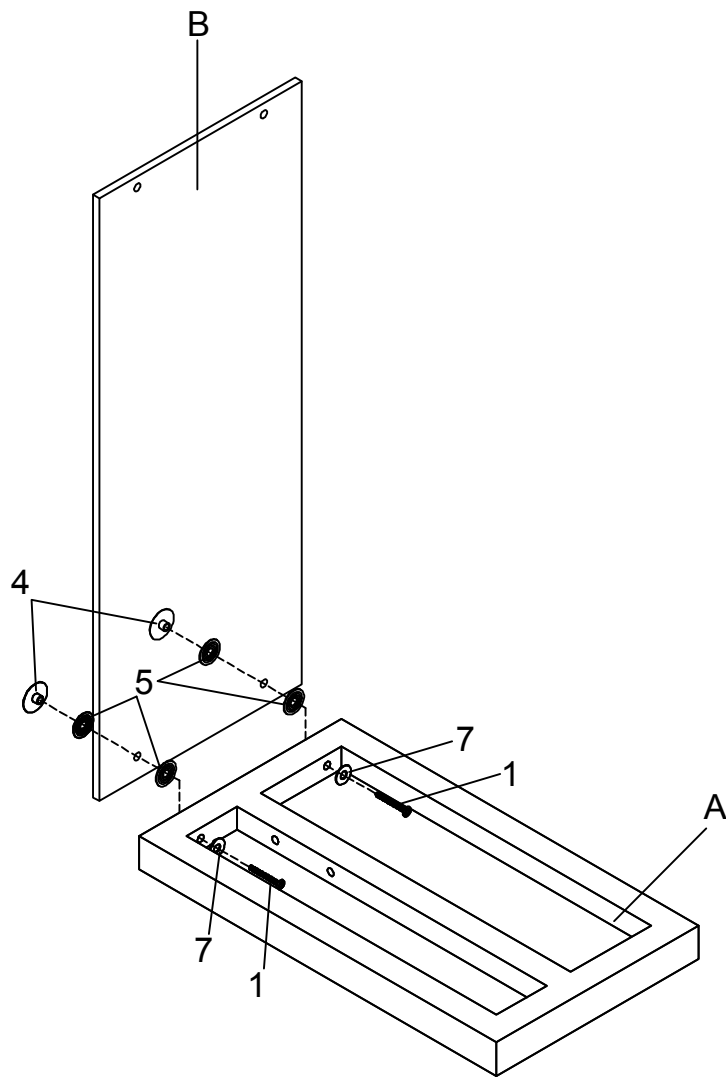

ASSEMBLY INSTRUCTIONS

STEP 2

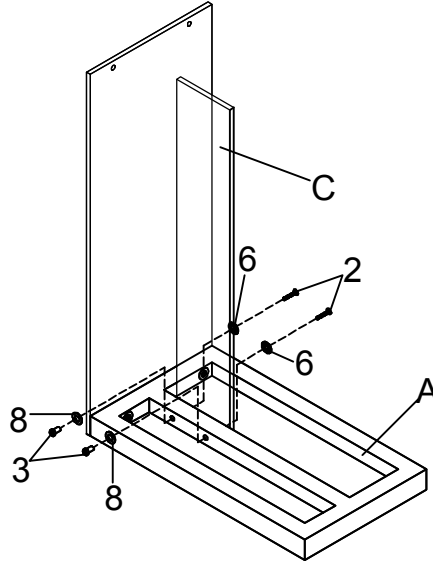

STEP 3

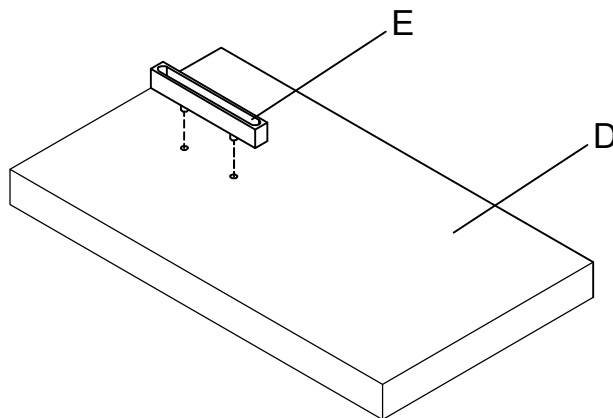

ASSEMBLY INSTRUCTIONS

STEP 4

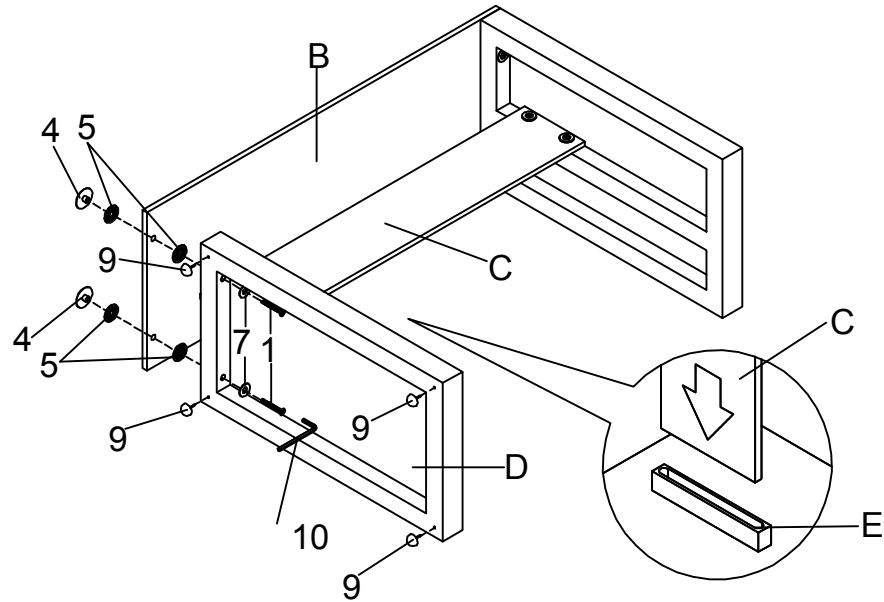

STEP 5

COMPLETE

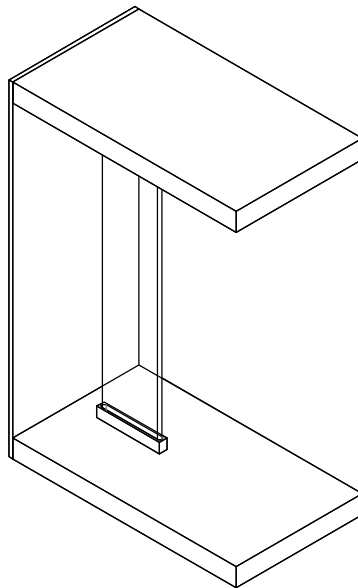

How to clean Acrylic product:
Using a dry soft microfiber cloth, lightly brush off any dust.
For additional care, dampen the cloth with warm water.
For deepest cleaning, use an Acrylic cleaner.

ASSEMBLY INSTRUCTIONS

Product Size : 254 X 470 X 629 H (MM)

Product Size : 10" X 18.5" X 24.75"

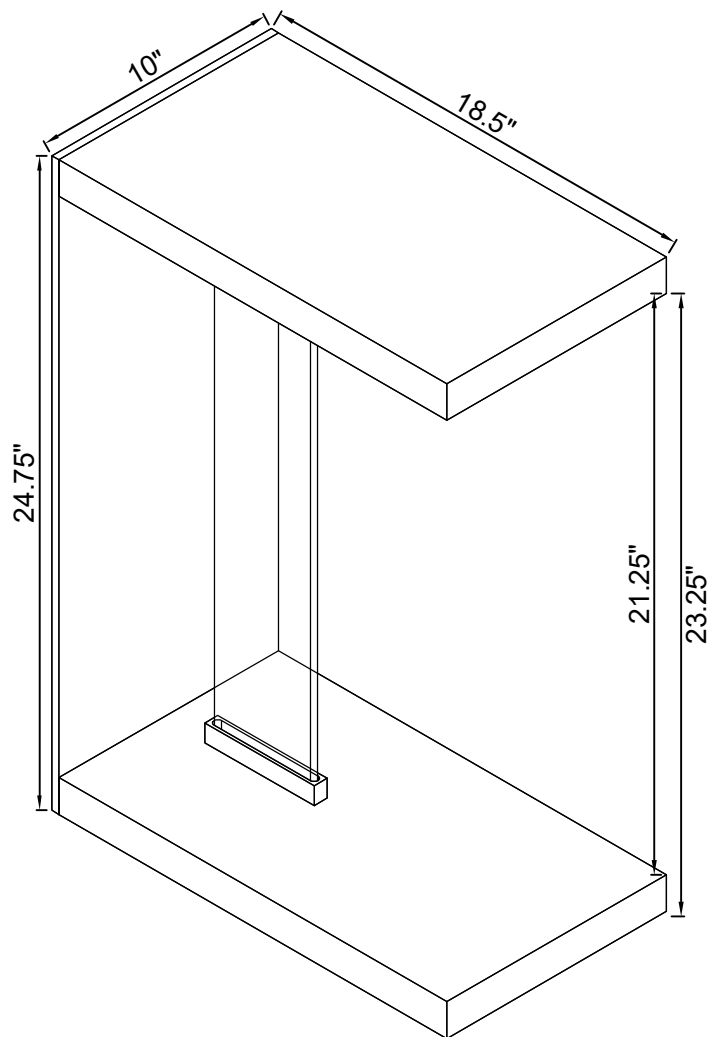

Note : Dimension tolerance $\pm 5\%$