

# ASSEMBLY INSTRUCTIONS

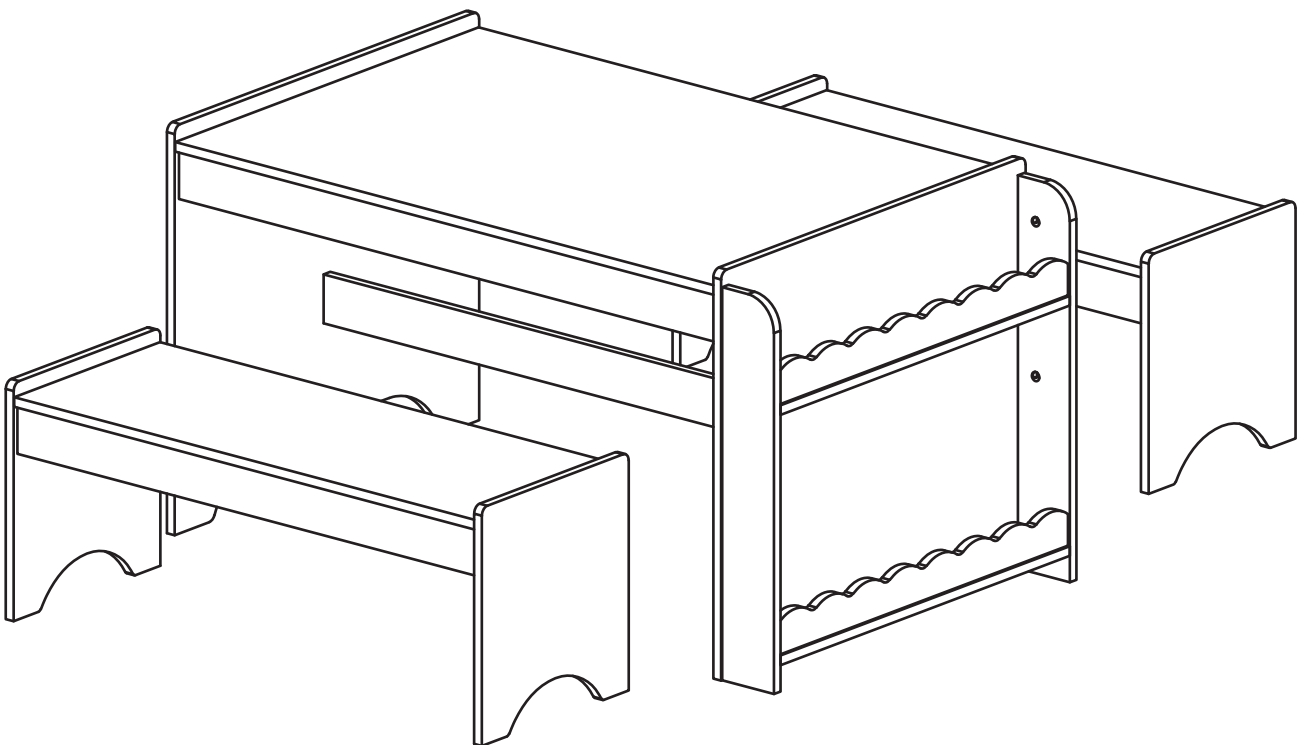

If you have any question about the installation, please do not hesitate to contact us, we will reply to you within 24 hours and do our best to help you solve all problems.

# Before You Start

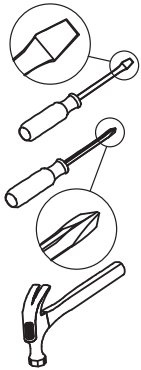

- ✓ Read through each step carefully and follow the proper order
- ✓ Separate and count all your parts and hardware
- ✓ Give yourself enough room for the assembly process
- ✓ Have the following tools: Flat Head Screwdriver, #2 Phillips Head Screwdriver and Hammer
- ✓ Caution: If using a power drill or power screwdriver for screwing, please be aware of to slow down and stop when screw is tight. Failure to do so may result in stripping the screw. (Assembly speed can be increased by using electric screwdriver)

# Helpful Hints

## PEOPLE NEEDED FOR ASSEMBLY: 1-2

- Open your item in the area you plan to keep it to avoid excessive heavy lifting.
- Identify, sort and count the parts before attempting assembly.
- Compression dowels are lightly tapped in with a hammer.
- Slides are labeled with an **R** (right) and **L** (left) for proper placement.
- Make sure to always face the point on the top of the Cam Lock towards the outer edge.
- If there is a back panel in the package, please install it to make sure your unit is complete and sturdy.
- Please fix all the screws provided for the back panel which can enhance product stability. If it is difficult to fix it when tightening, it can be fixed with the help of a hammer and then tightened.
- Do NOT use harsh chemicals or abrasive cleaners on this item.
- Never push, pull, or drag your furniture.
- Do not mix old and new batteries.
- Do not mix alkaline, standard (carbon-zinc), or re-chargeable batteries.



**WARNING**  
**CHOKING HAZARD-**  
Small parts. Not for children under 3 yrs.

**WARNING:**  
Assembly by an adult

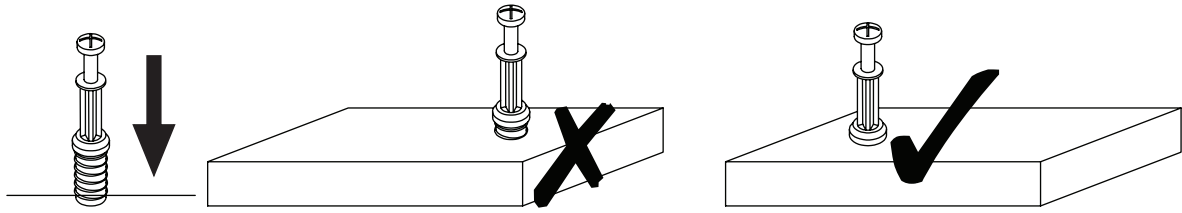

Tighten quickfit until shoulder is flush with panel. Do not overtighten or undertighten.

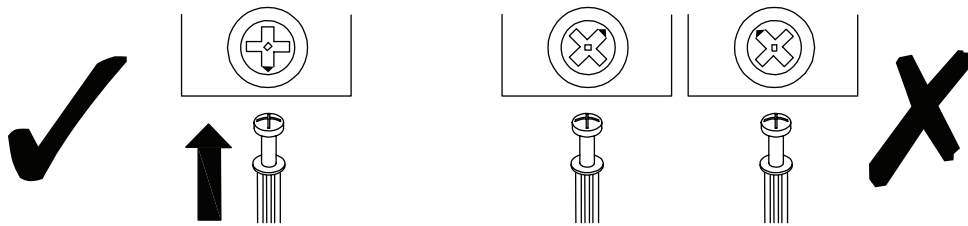

When fitting cam lock, ensure starting position is correct before you insert connecting quickfit.

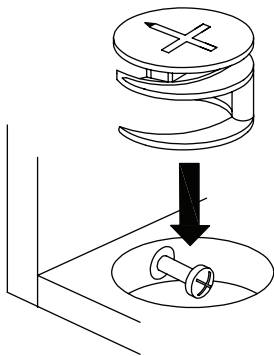

Quickfit head should be in the centre of the cam lock when the two panels are joined.  
Cam lock should be inserted before quickfit.

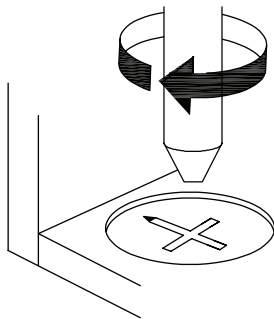





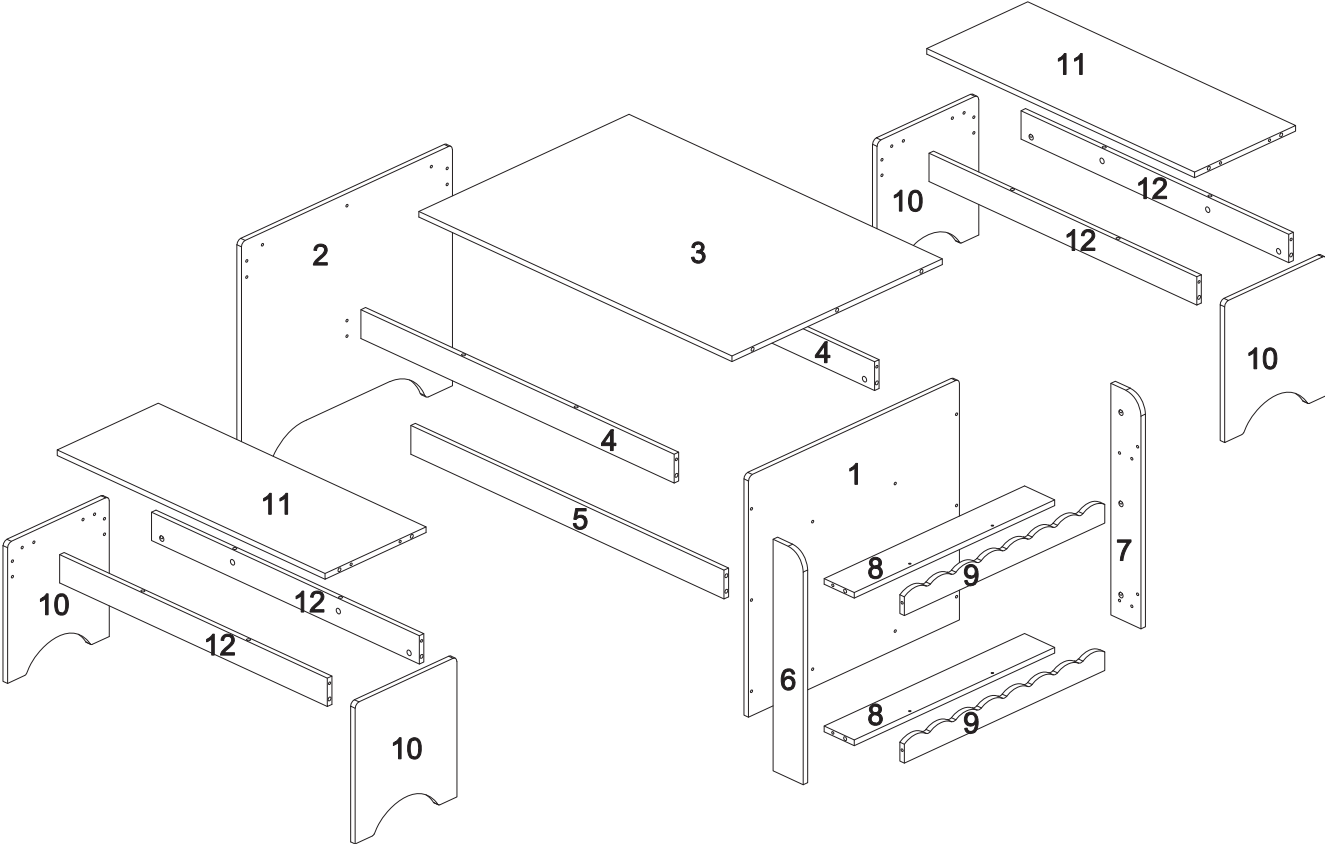

Turn cam lock clockwise to tighten.

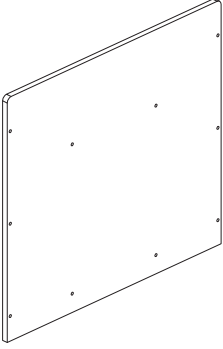
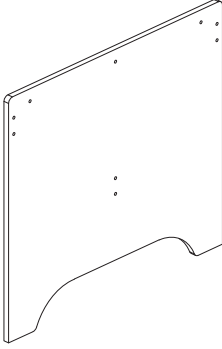
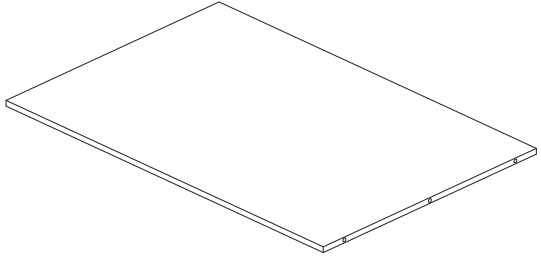
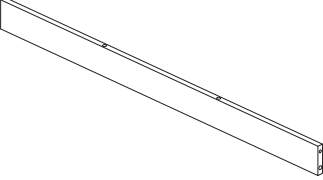
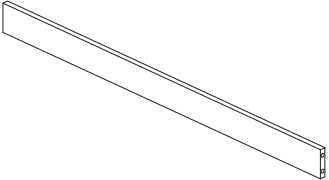
# EXPLODED DRAWING

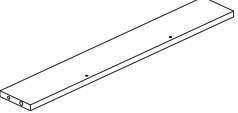

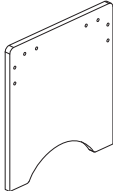
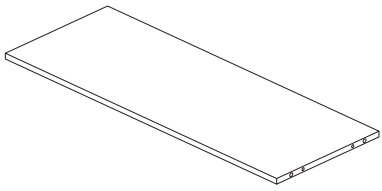
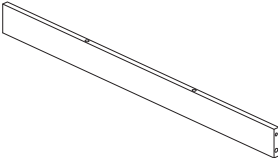
# Part List

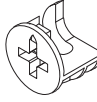
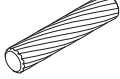
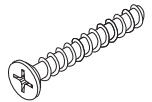
 <p><b>1: 1pc</b></p>	 <p><b>2: 1pc</b></p>	 <p><b>3: 1pc</b></p>		
 <p><b>4: 2pcs</b></p>	 <p><b>5: 1pc</b></p>	 <p><b>6: 1pc</b></p>	 <p><b>7: 1pc</b></p>	
 <p><b>8: 2pcs</b></p>	 <p><b>9: 2pcs</b></p>	 <p><b>10: 4pcs</b></p>	 <p><b>11: 2pcs</b></p>	
 <p><b>12: 4pcs</b></p>	 <p><b>A: 52pcs +5(spare)</b></p>	 <p><b>B: 52pcs +5(spare)</b></p>	 <p><b>∅ 6x30mm C: 32pcs +3(spare)</b></p>	 <p><b>∅ 4x35mm D: 4pcs</b></p>

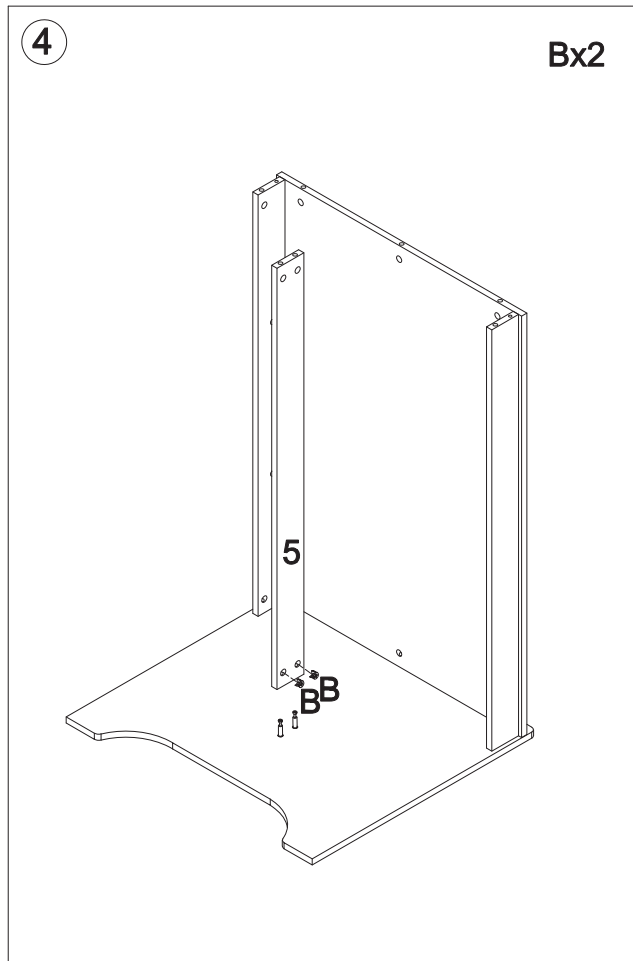
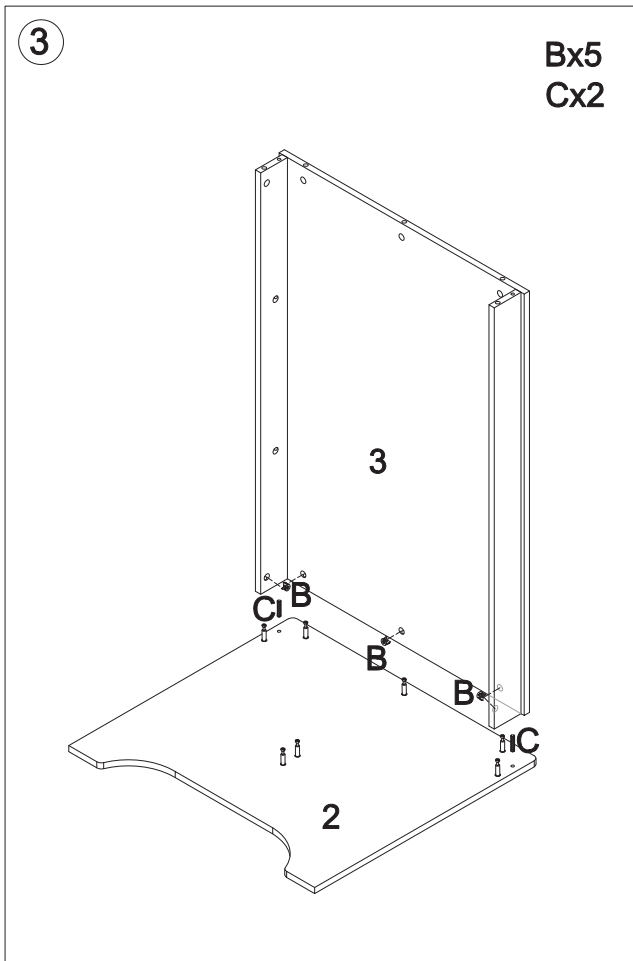
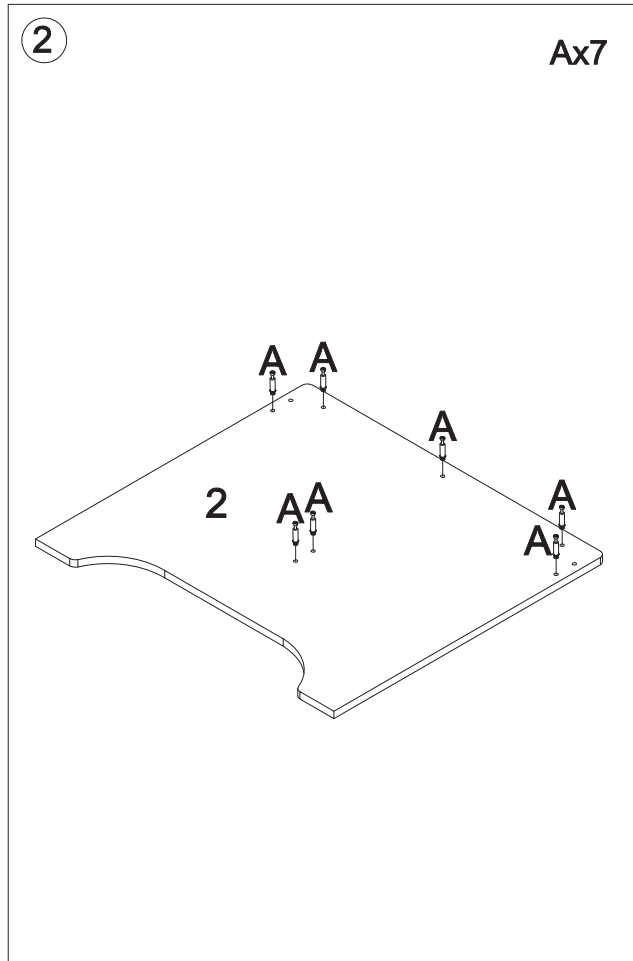
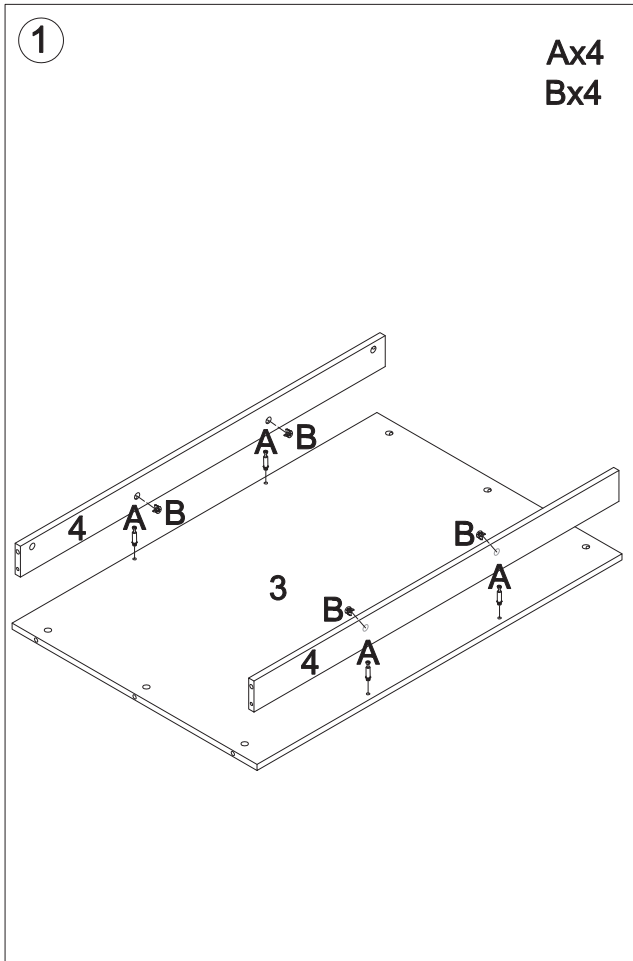

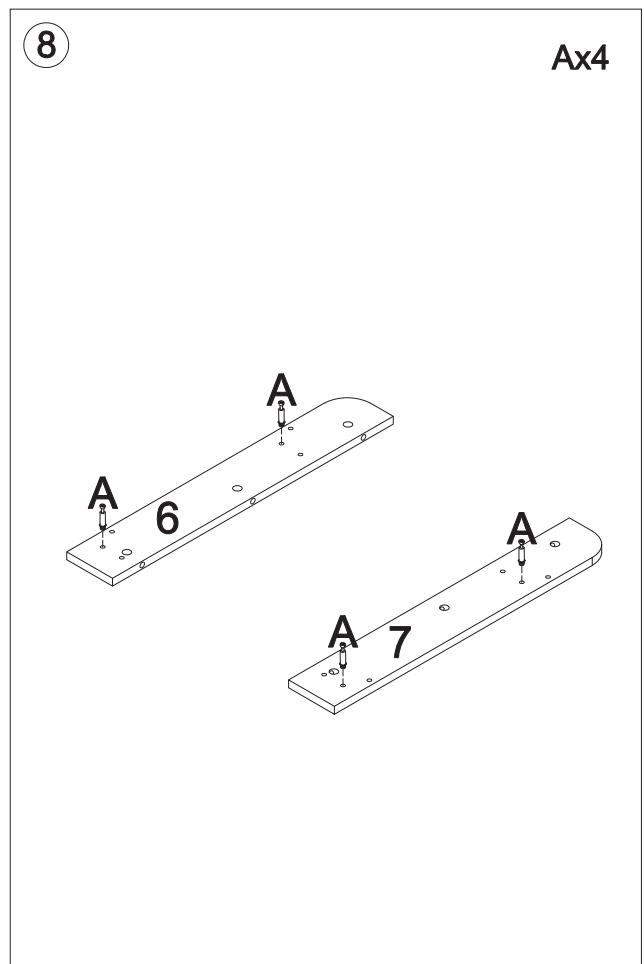
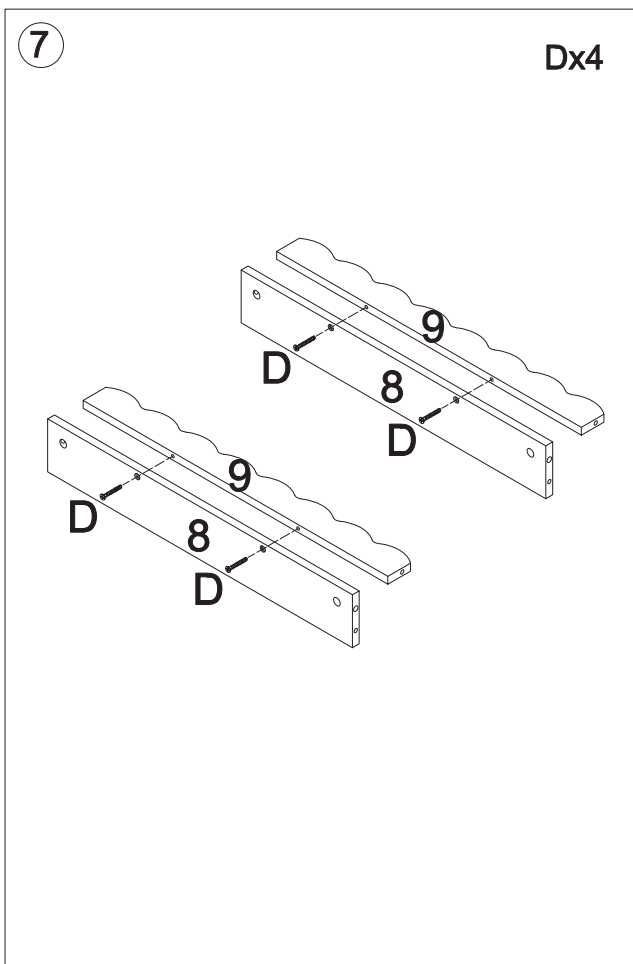
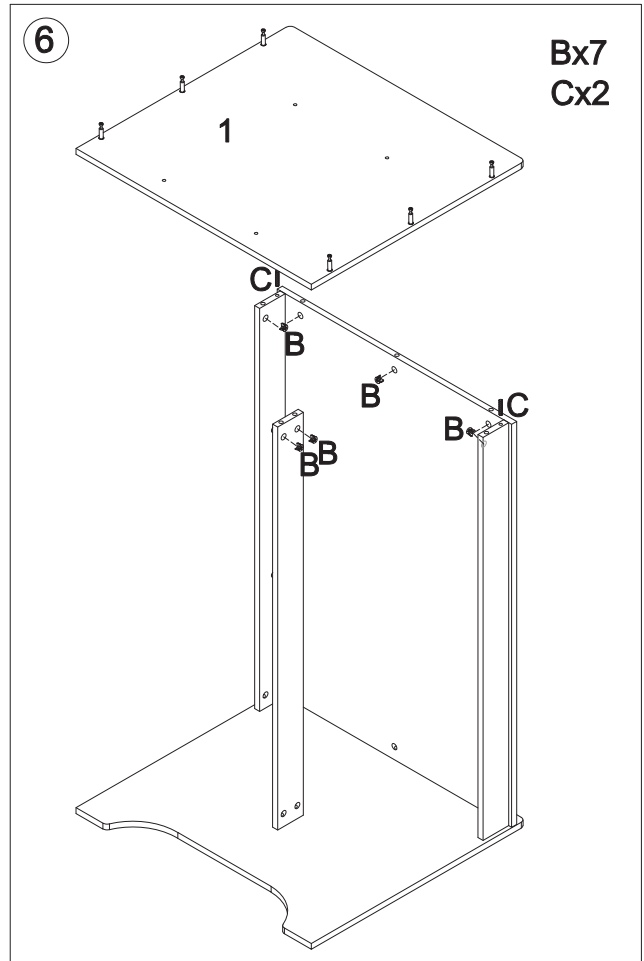
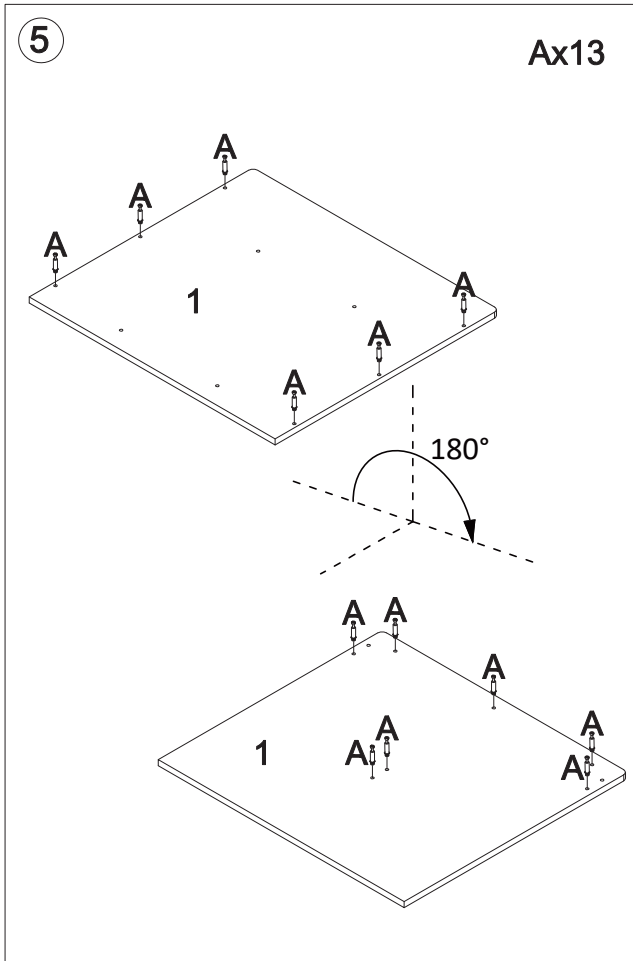

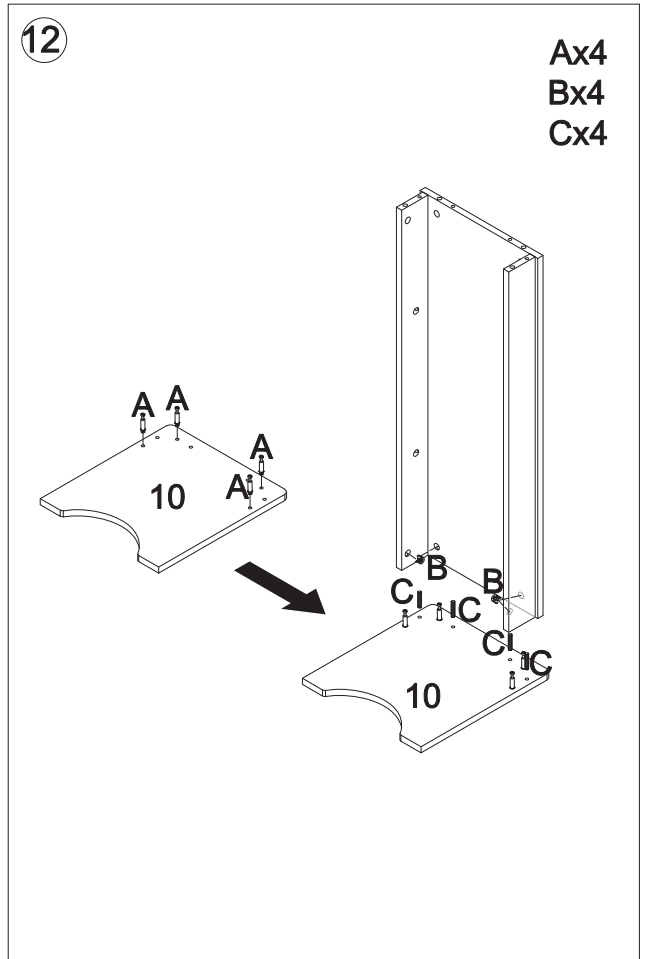
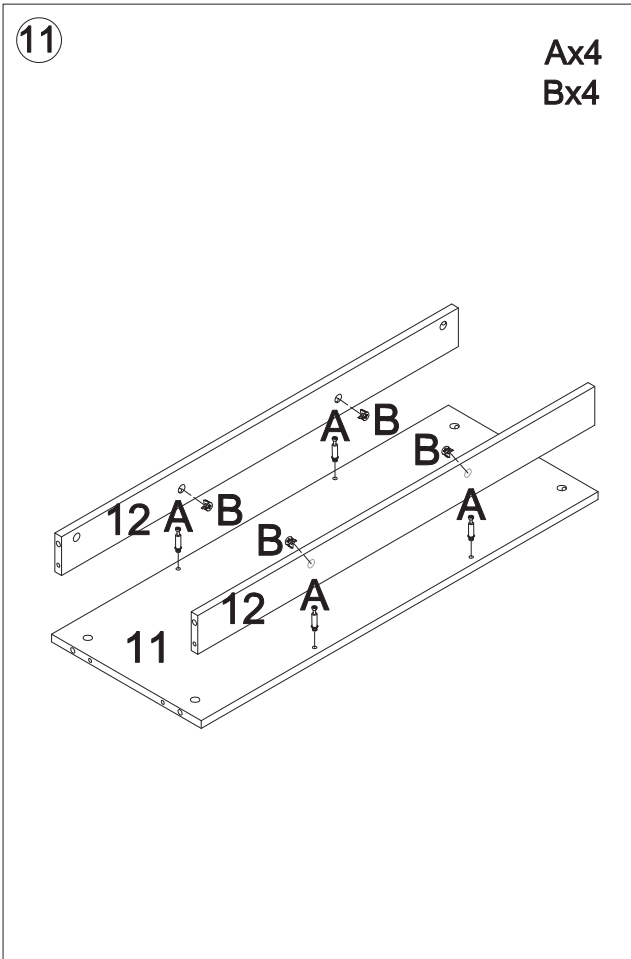
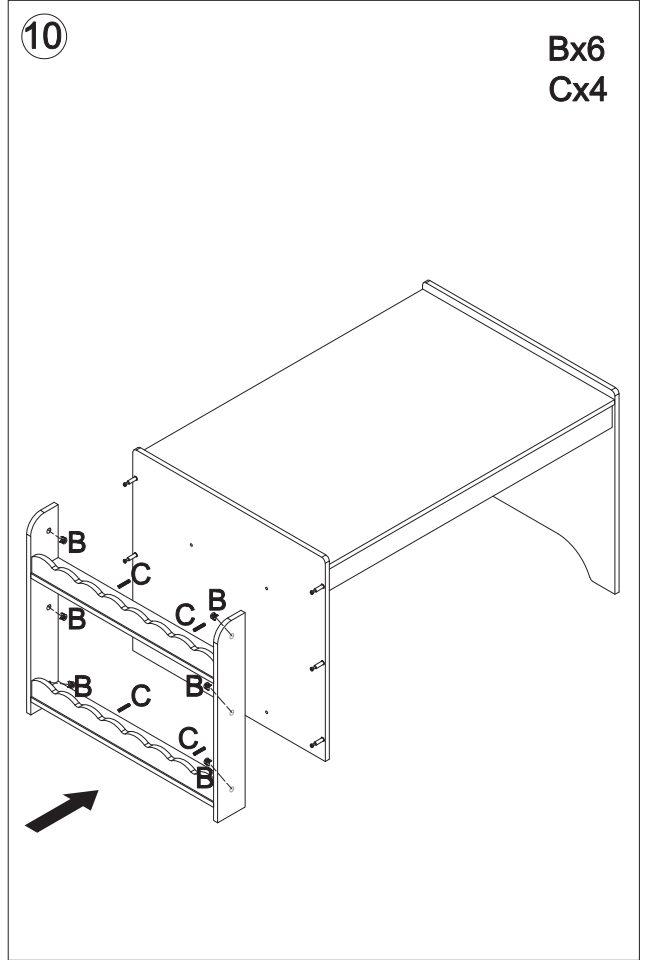
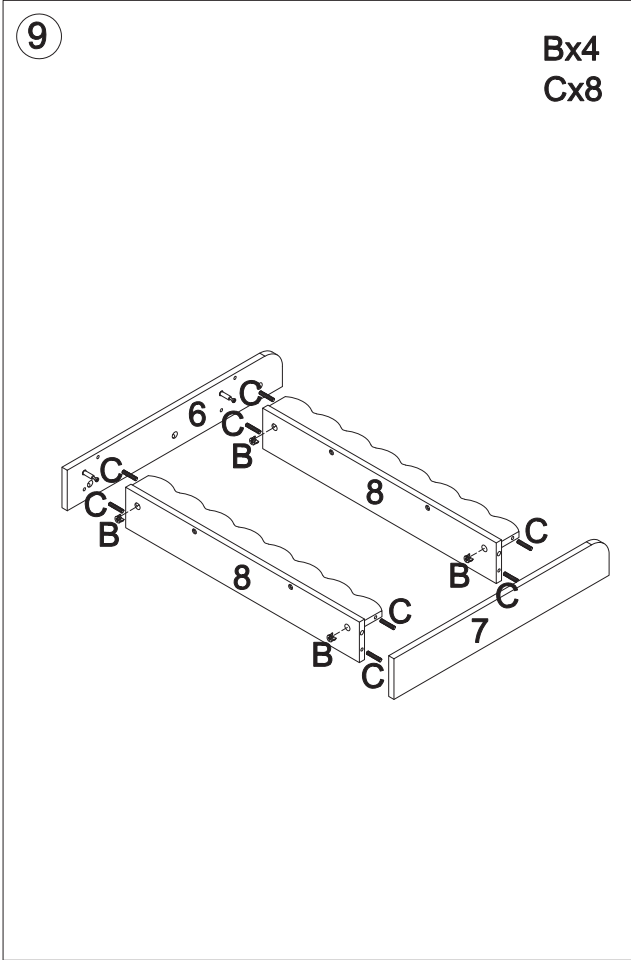

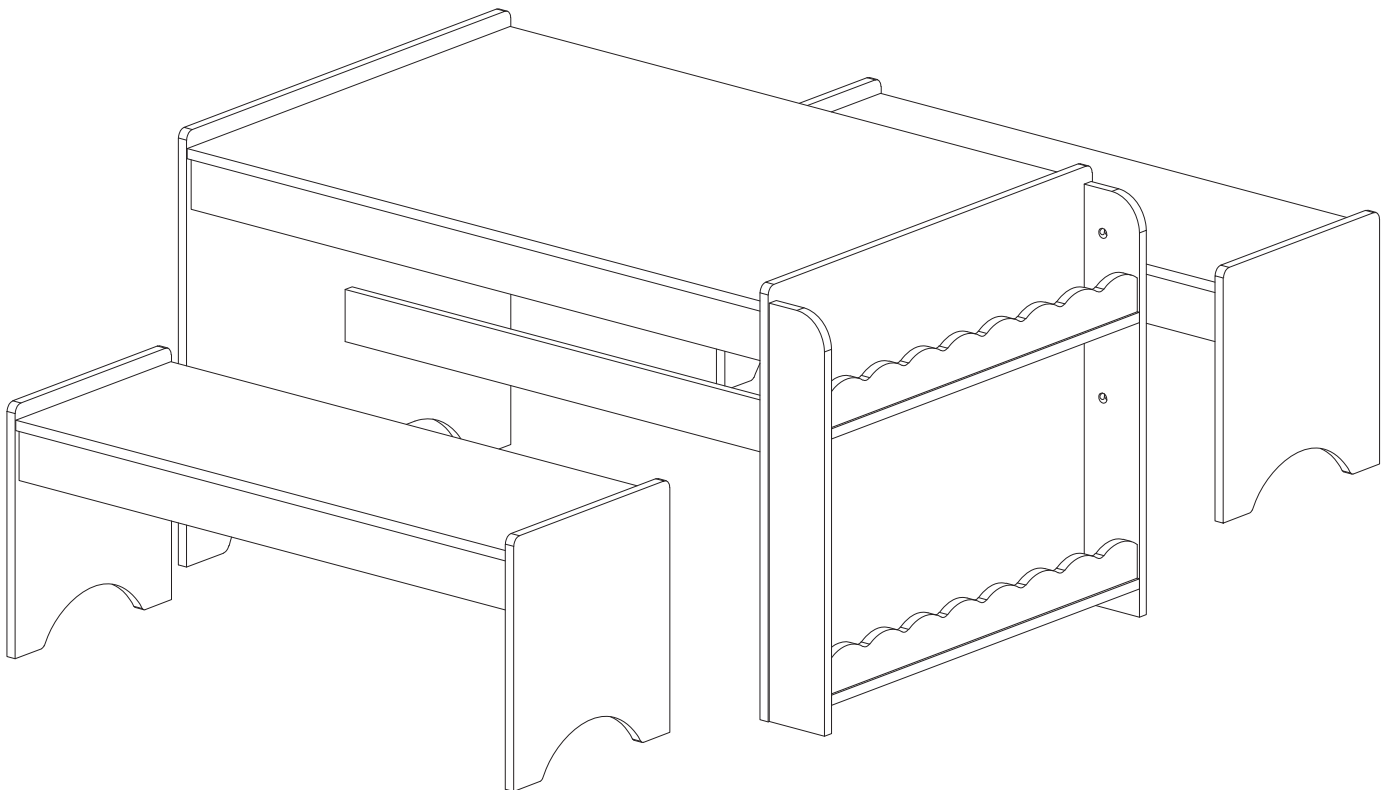
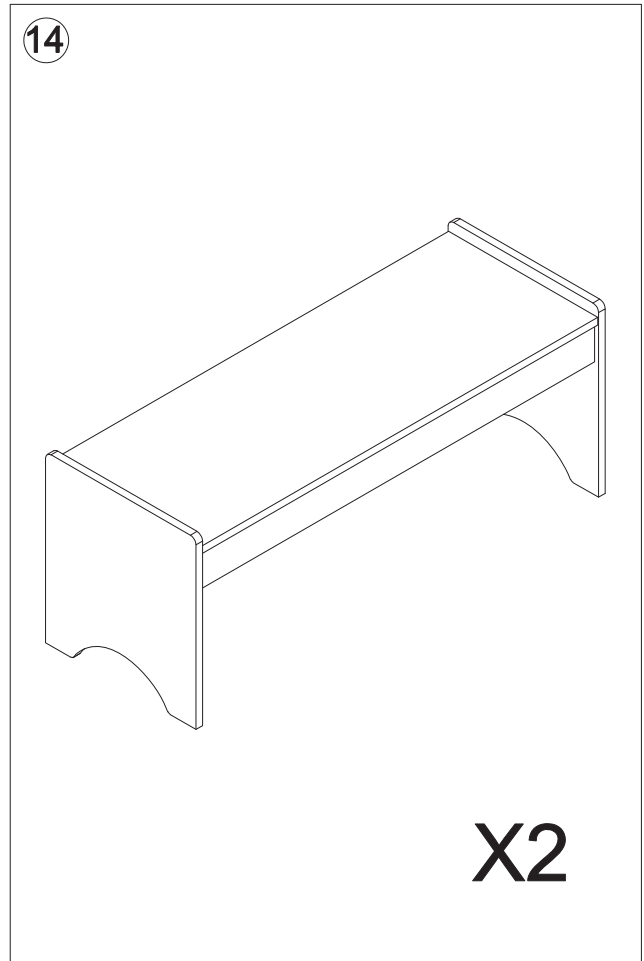
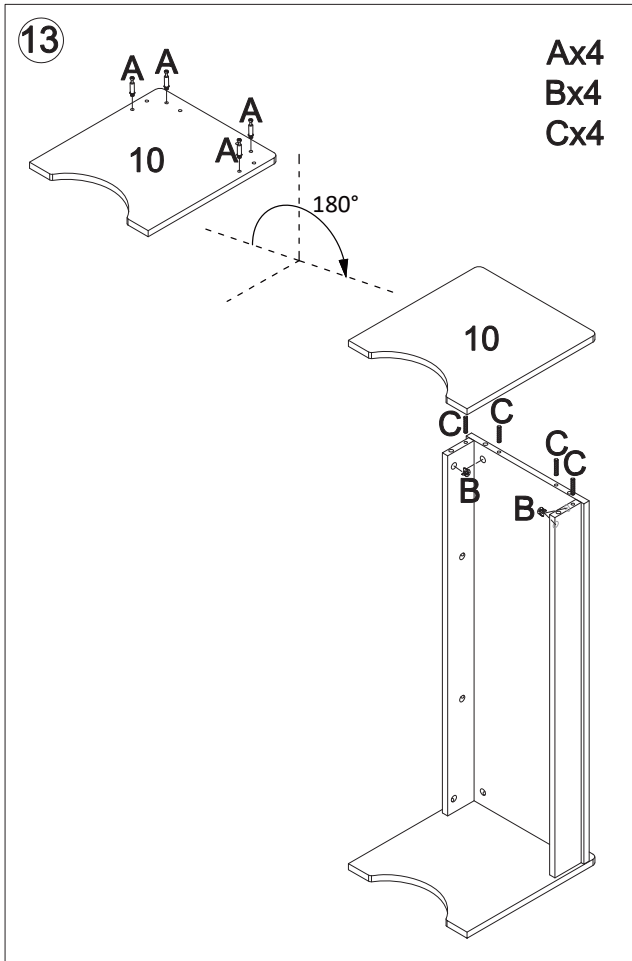

# AFTER-SALE SERVICE

If you have any suggestions for our products or find that the products have quality problems, please contact us first, our after-sales team will reply you within 24 hours, and we will do our best to give you solutions until you are satisfied.

## Guaranteed Customer Service

Your shopping experience is very important to us!

Feel unsatisfied? **Contact us!**

Have any questions? **Contact us!**

Wanna share your experience with our products?

Share your pictures with us.

Any suggestions? **Contact us!**

We gotcha back!