

PLEASE DO NOT RETURN TO STORE

User Manual
ASSEMBLY INSTRUCTION

Right corner from inside
78.7L*62.9W*29.9H Inch







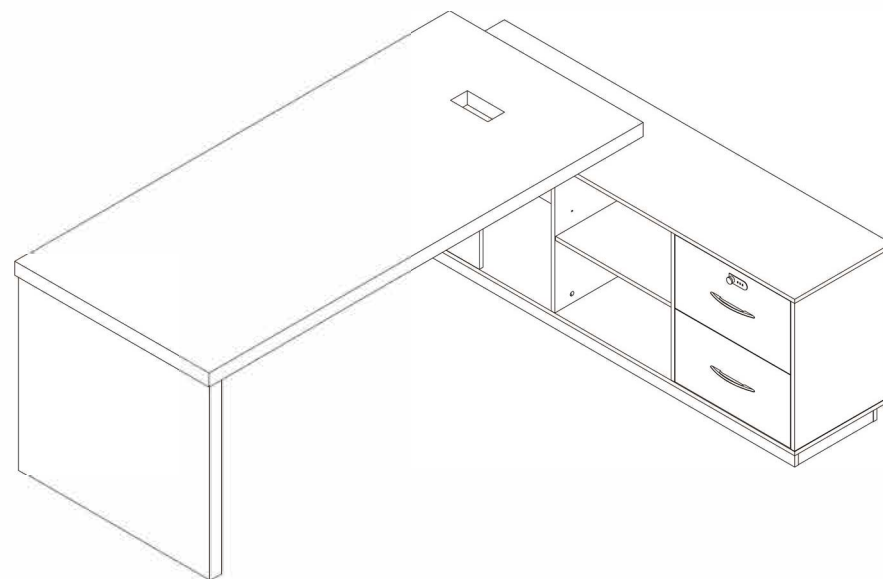

















Please do not return this product to the retailer!
We are able to assist you in ANY way!

If you find that you have any trouble with assembly or
missing or damaged parts please contact the seller.



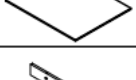
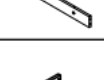







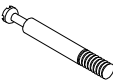

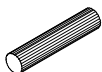

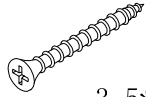
Parts List

NO.	Drawing	Dimension	QTY
1		1800*800*50mm	*1
2		700*790*50mm	*1
3		1541*600*15mm	*1
4		1541*140*45mm	*1
5		700*500*25mm	*1
6		1600*400*15mm	*1
7		530*383*15mm	*1
8		530*383*15mm	*1
9		530*383*15mm	*1
10		530*366*15mm	*1
11		530*295*15mm	*1
12		478*380*15mm	*1

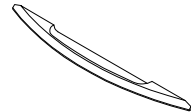
NO.	Drawing	Dimension	QTY
13		1598*530*15mm	*1
14		1600*400*15mm	*1
15		476*262*15mm	*1
16		476*262*15mm	*1
17		350*180*15mm	*2
18		350*180*15mm	*2
19		425*180*15mm	*2
20		435*344*4mm	*2
21		622*70*15mm	*1
22		150*70*15mm	*2
23		1540*70*15mm	*2
24		310*70*15mm	*3
25		622*70*15mm	*1

Hardware Fitting

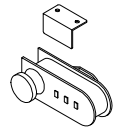
NO.	Drawing	QTY
A		*95
B		*95
C	 8*40mm	*2
D		*2
E	 3.5*35mm	*8
F	 3.5*14mm	*20

NO.	Drawing	QTY
G		*2
H	 4*18mm	*4
I	 6*25mm	*2
J	 4mm	*1
K		*1
L		*4

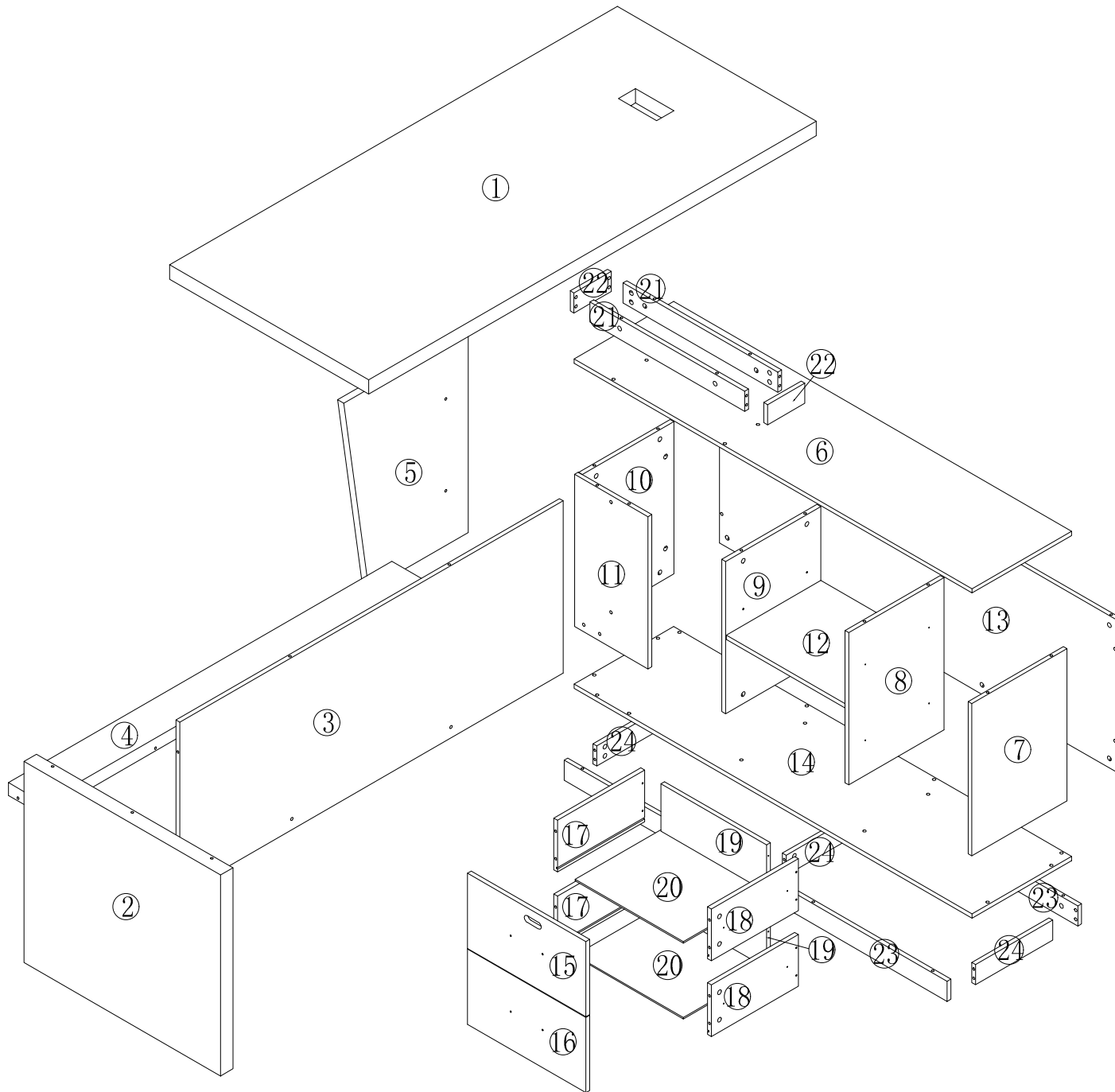

Cam Coupling Using Methods

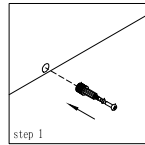

Step1.
Connect the cam coupling A as directed in the assembly instructions using hand.

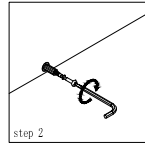

Step2.
Screw the cam coupling A as directed in the assembly instructions.

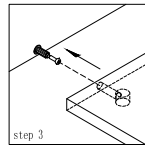

Step3.
Push the cam coupling A into the entry hole.

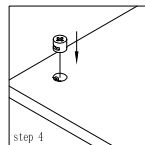

Step4.
Insert the cam coupling B as shown in the instructions.

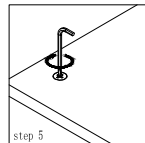

Step5.
Turn the cam coupling B clockwise with a screwdriver

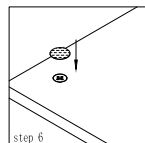

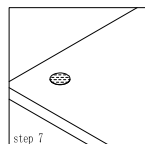

Step6.
Put on Beautycam.



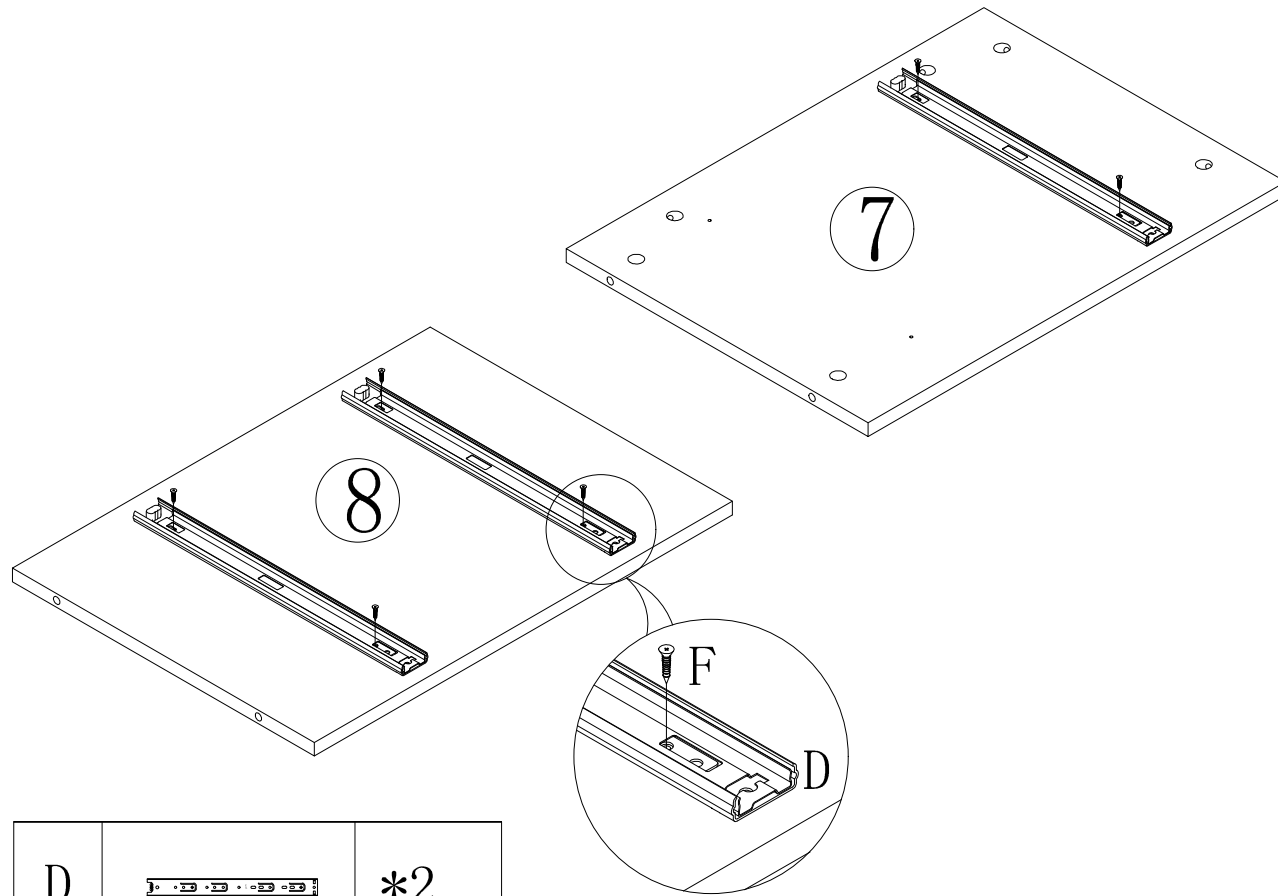

Step7.
Finished.

You should feel a click when the camlock is locked in place.
The joint is now secure.



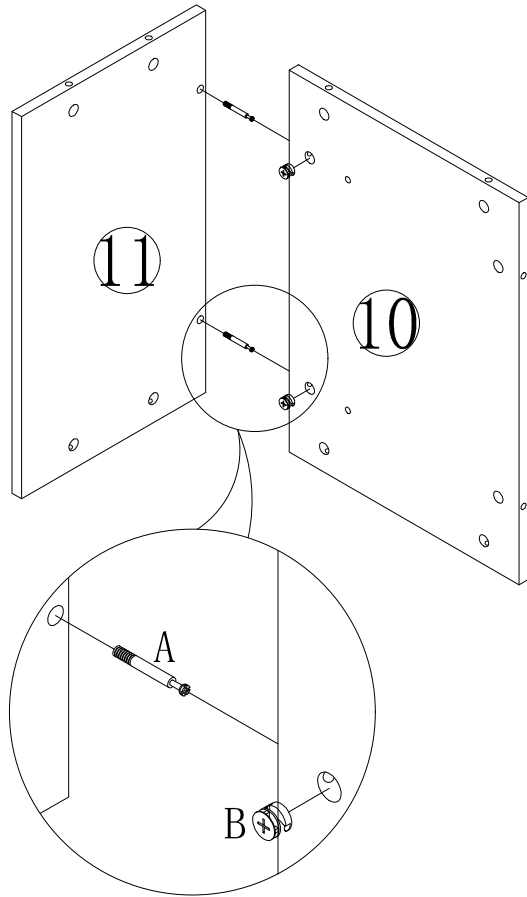

D		*2
F	 3.5*14mm	*8



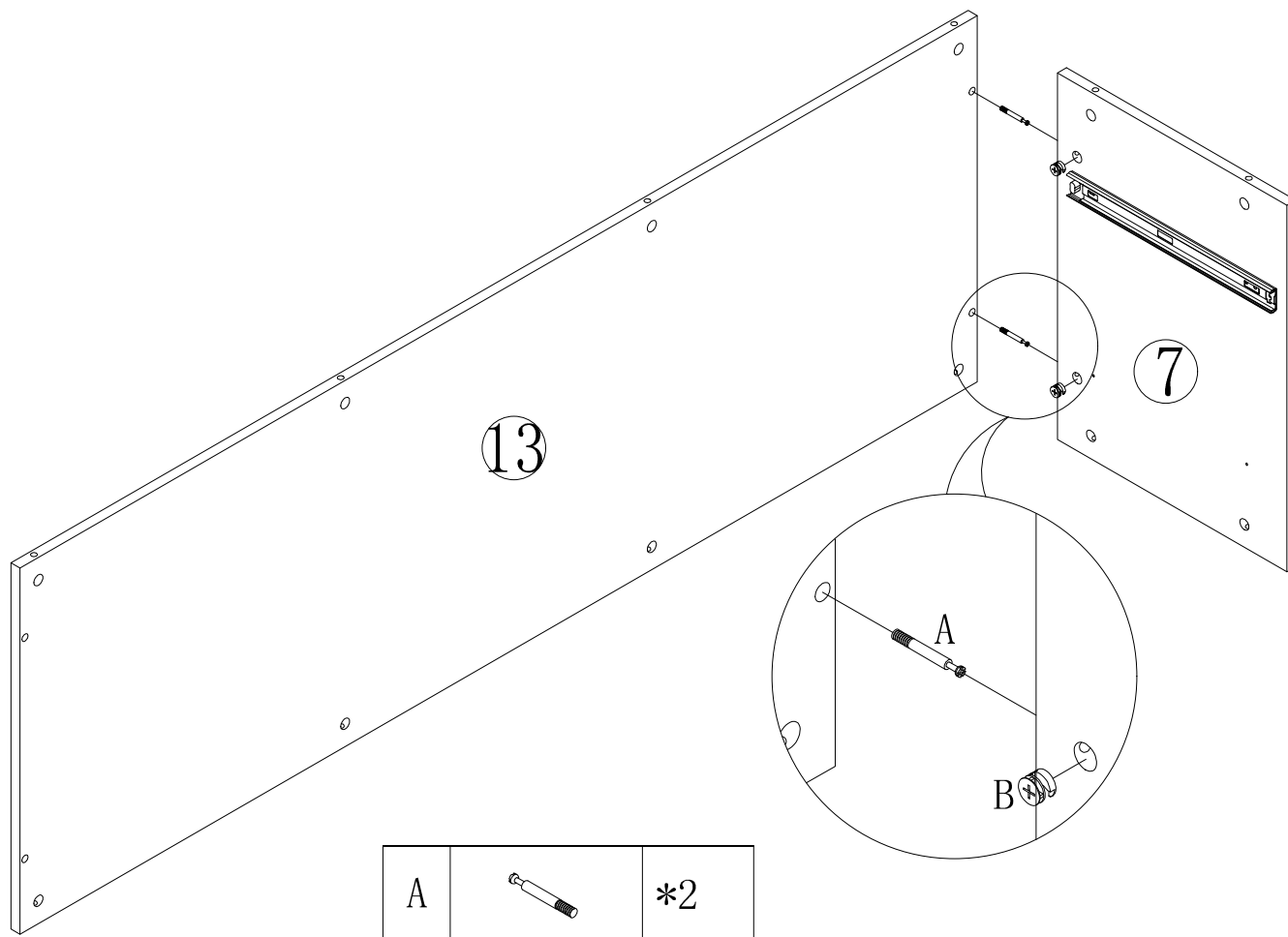

A		*2
B		*2



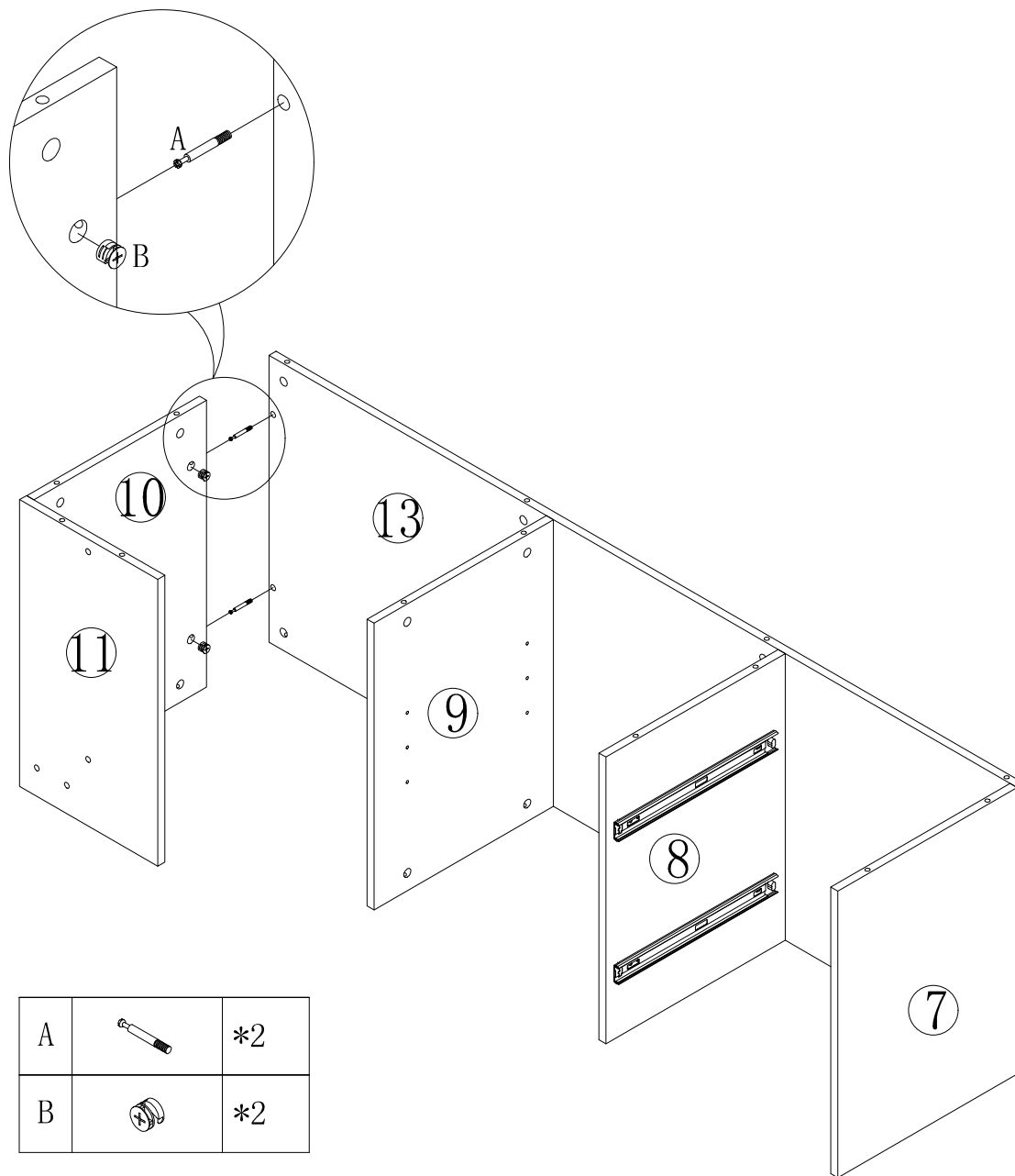

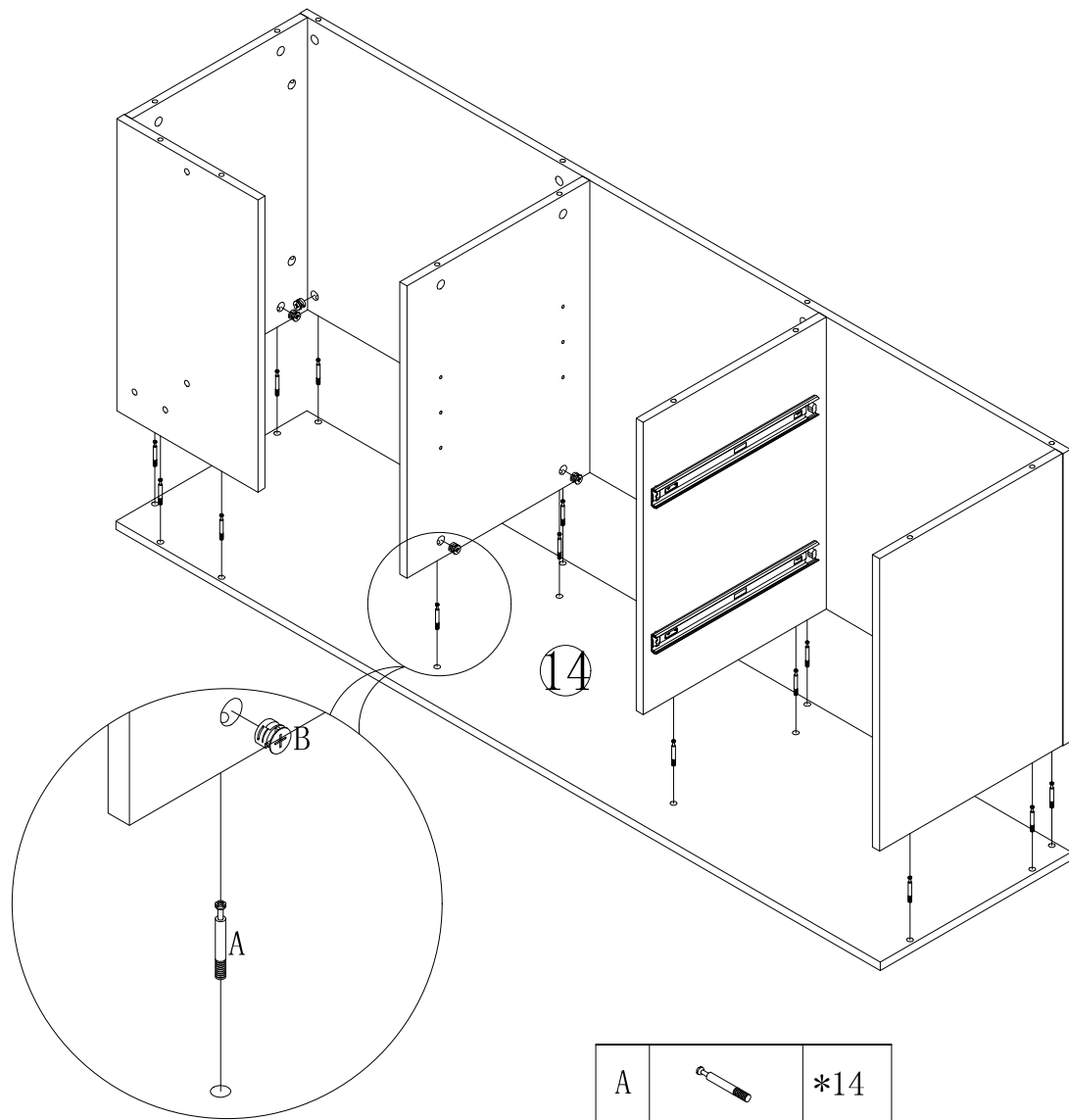

A		*2
B		*2



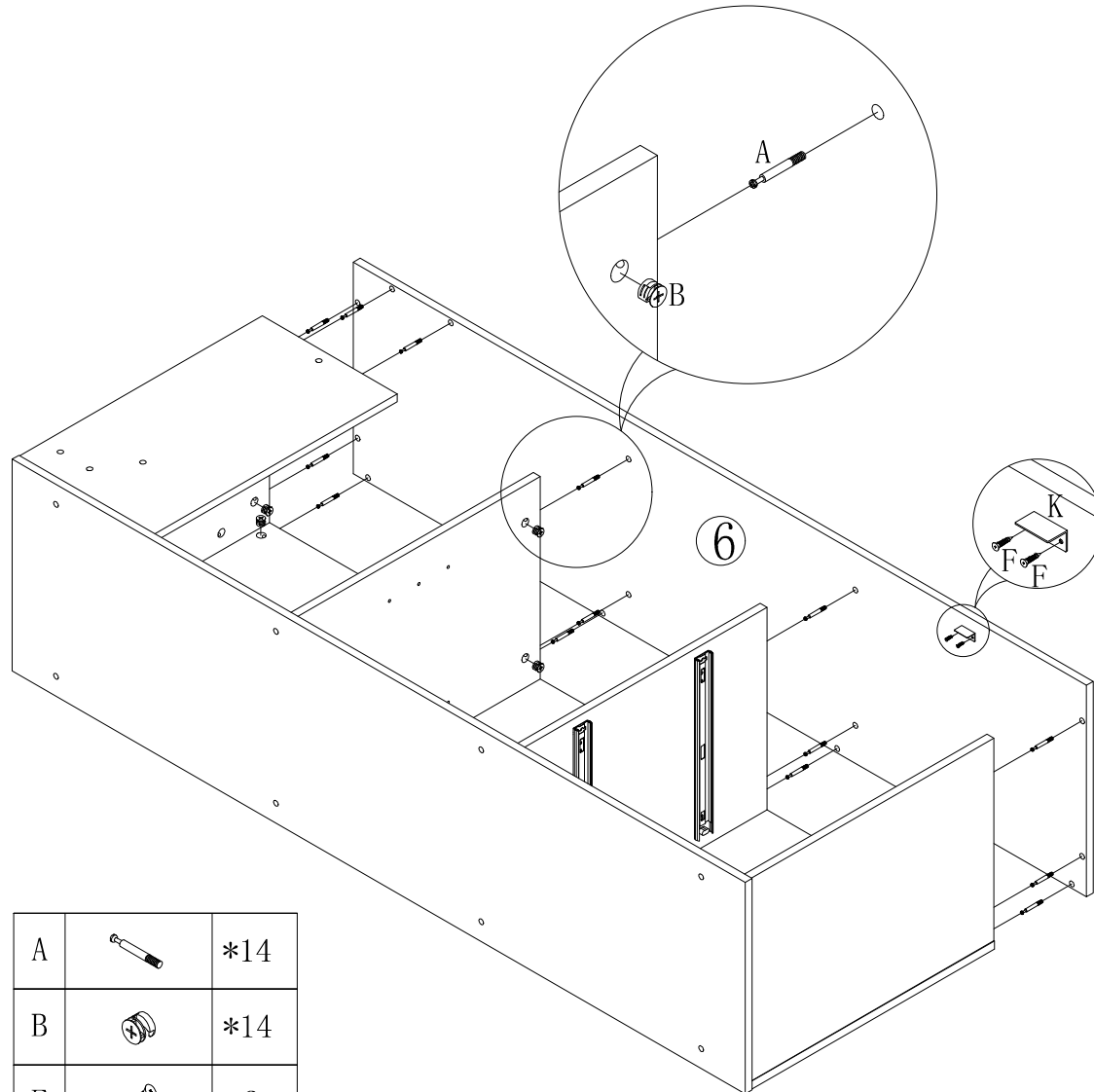



A		*14
B		*14

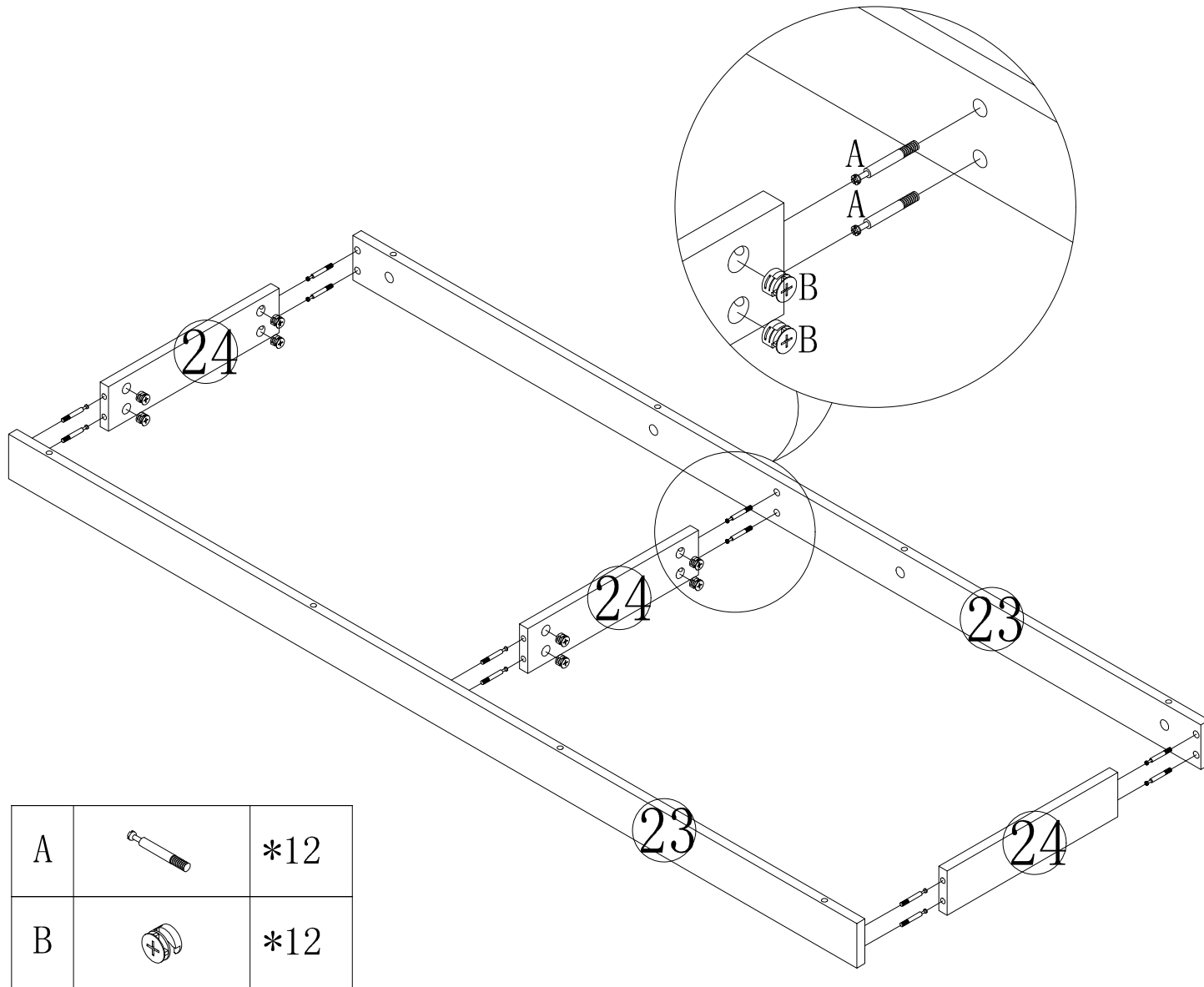

A		*14
B		*14
F	 3,5*14mm	*2
K		*1



A		*12
B		*12

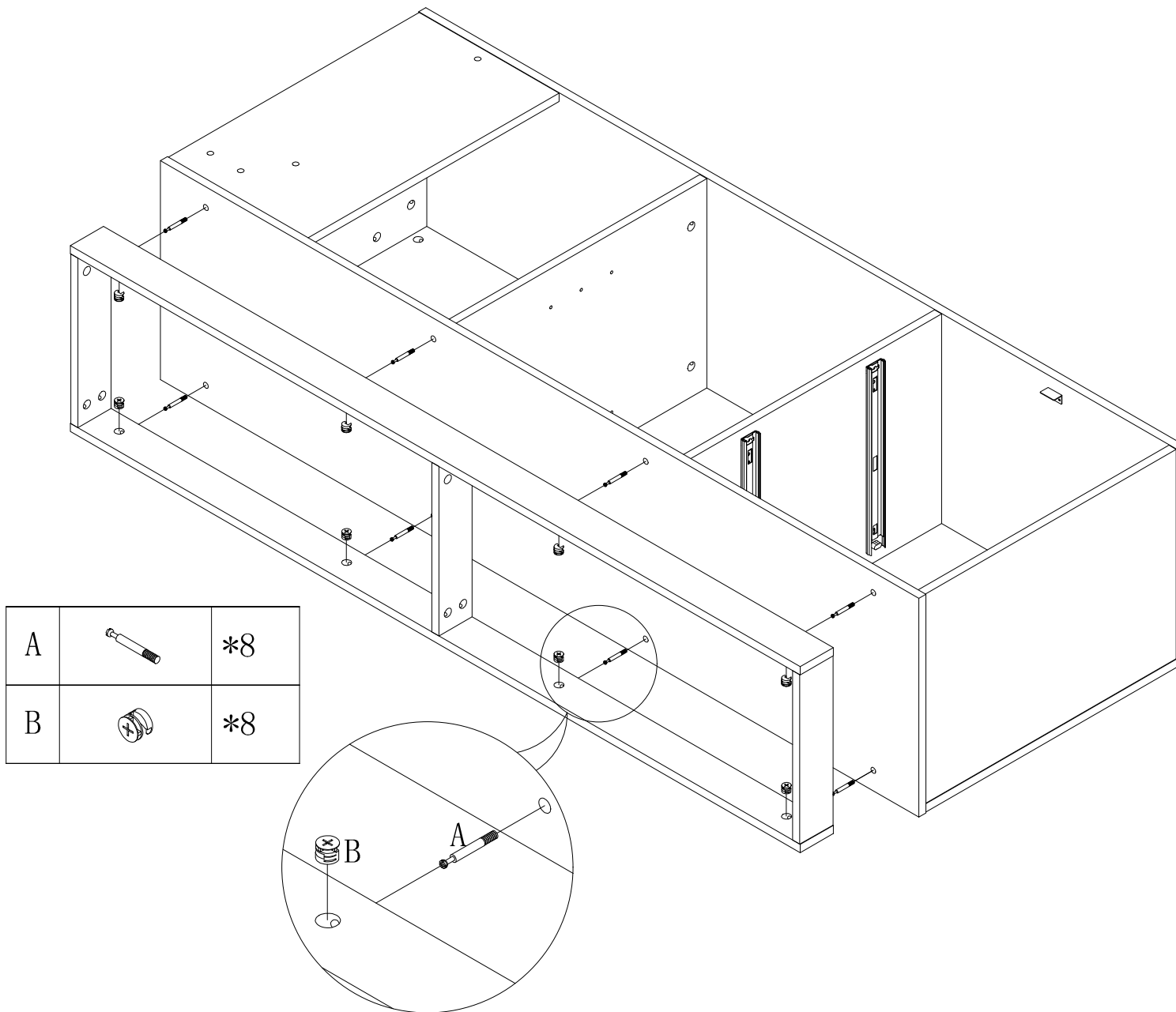

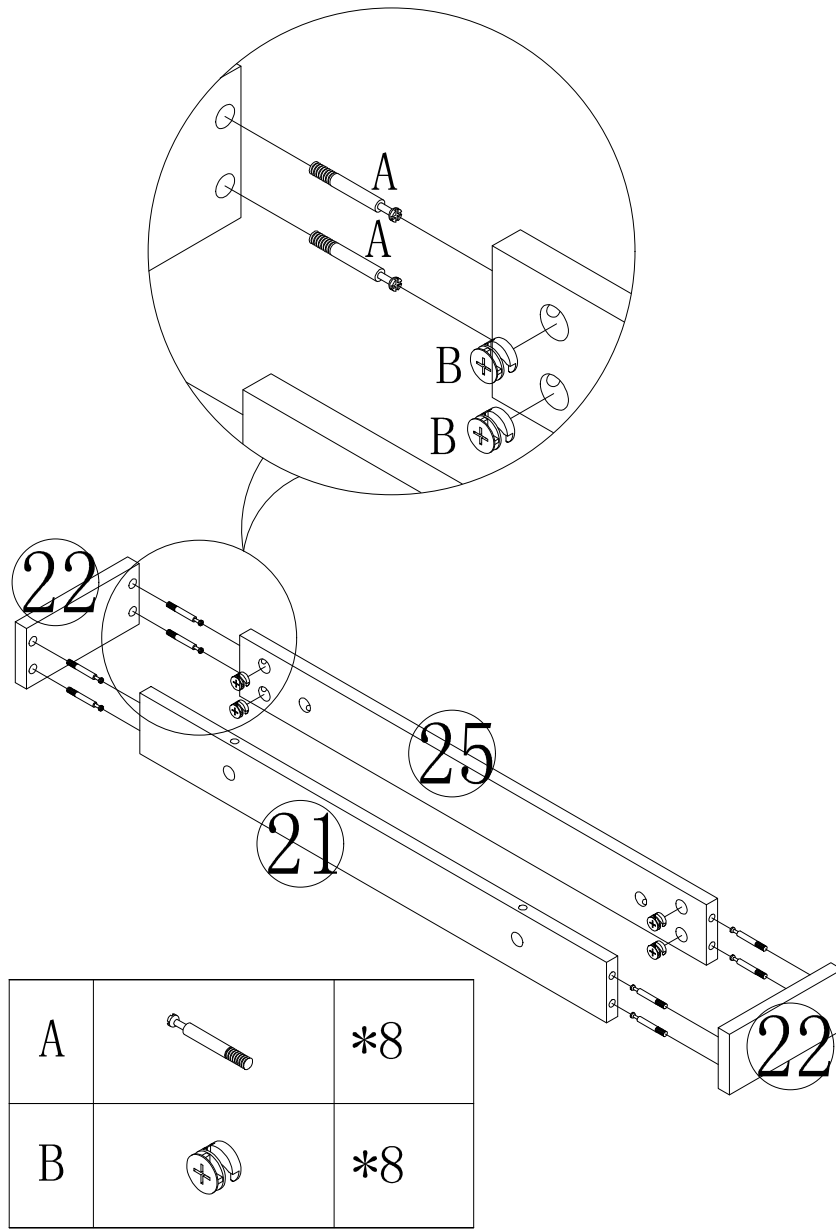

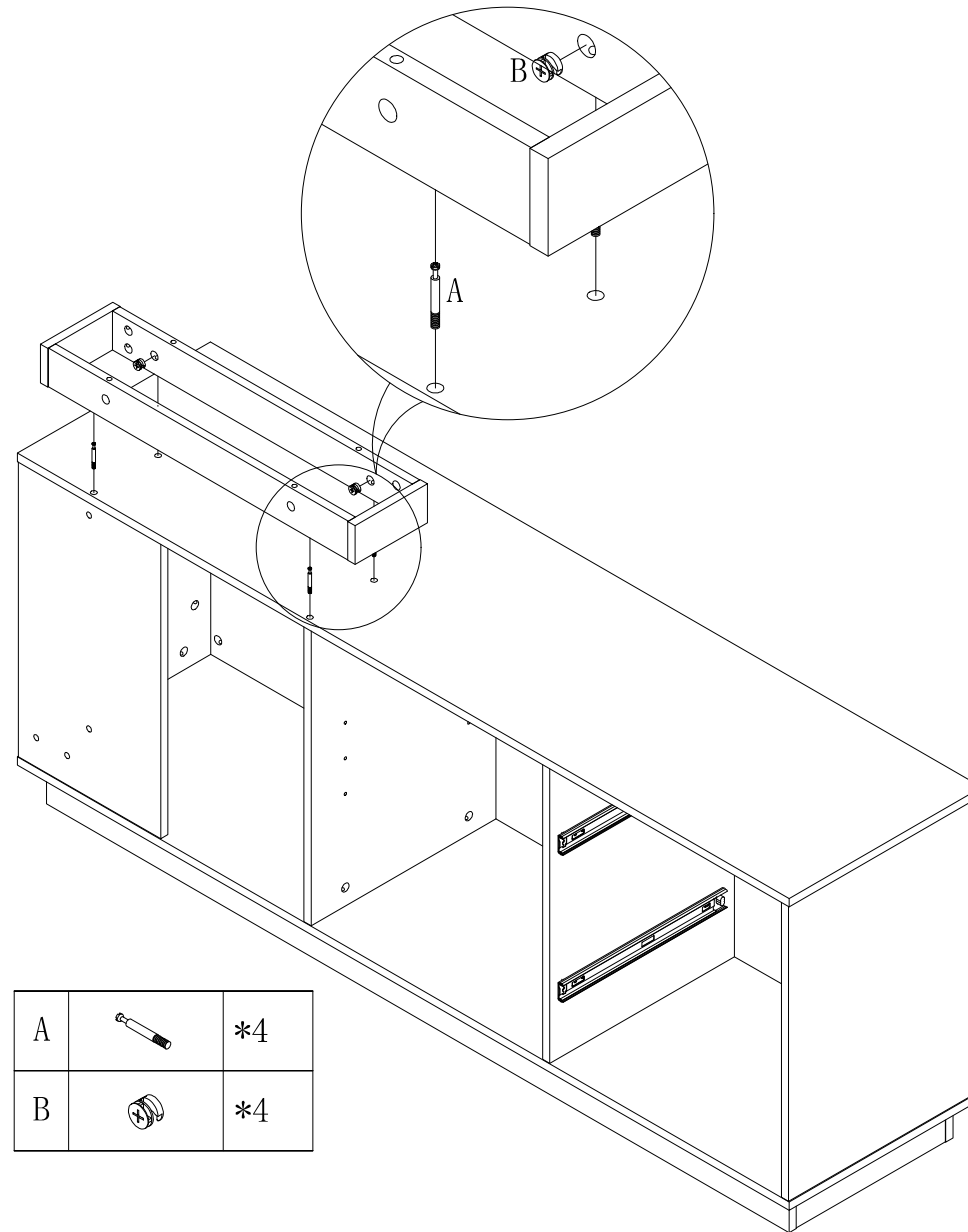

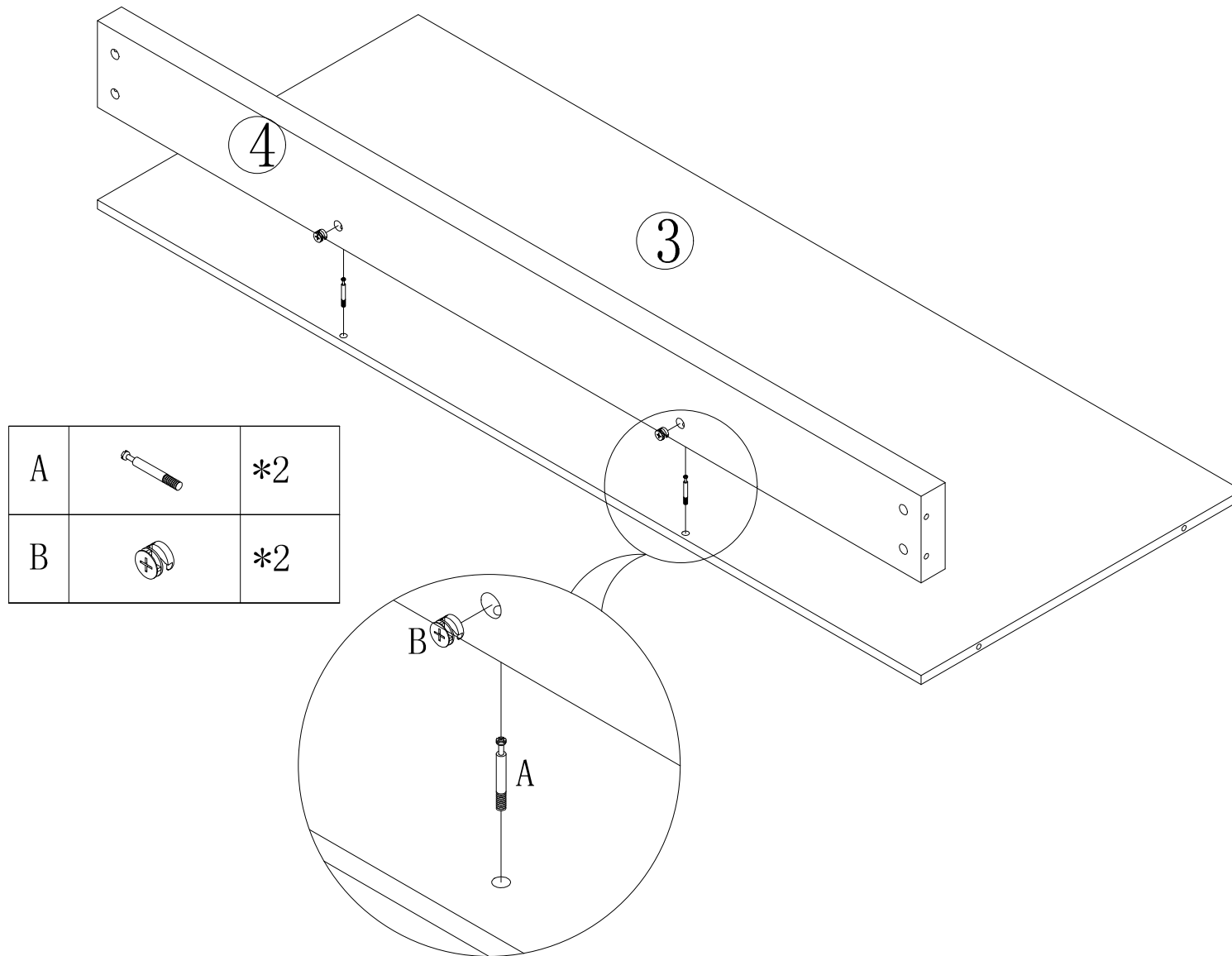

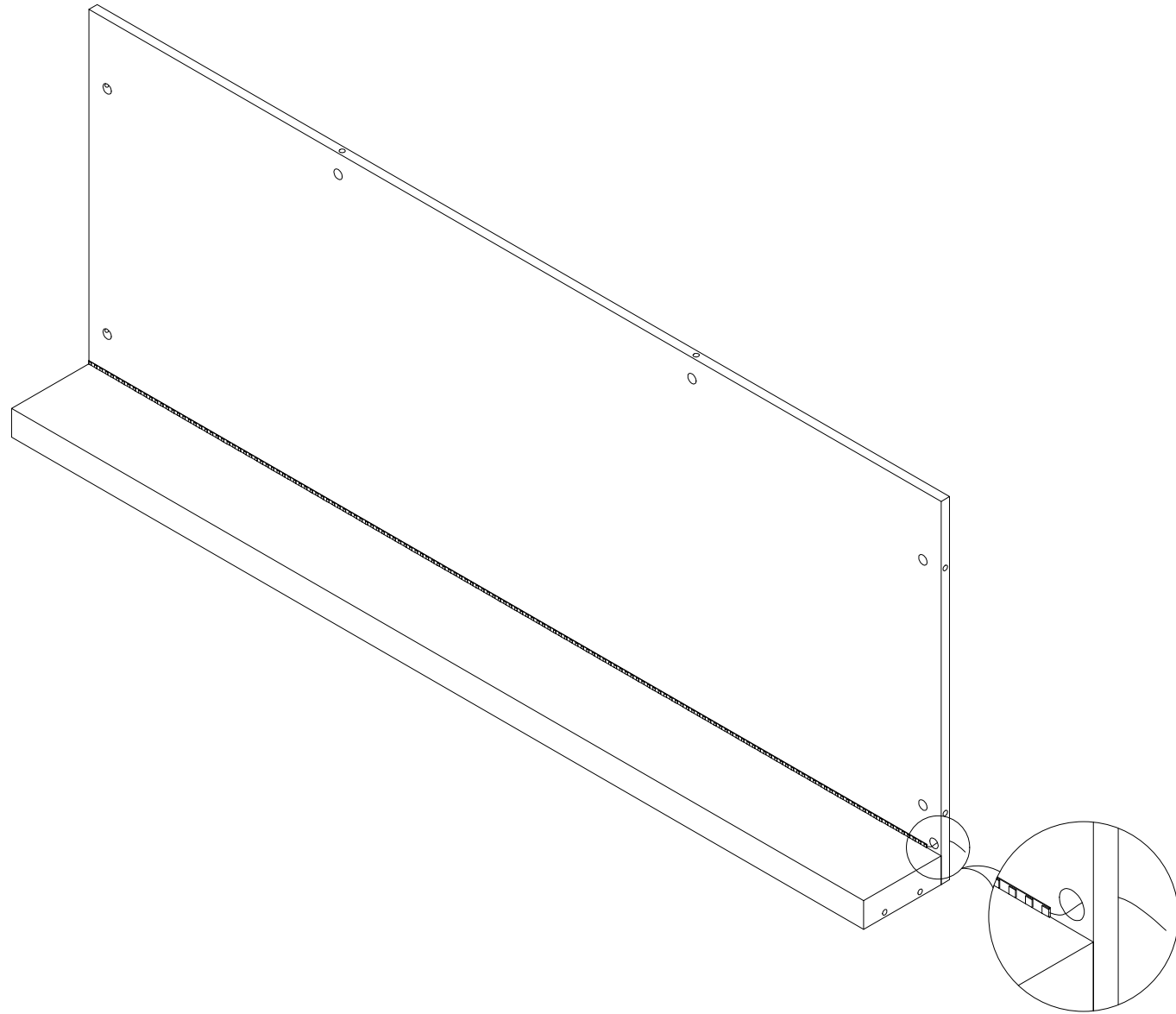

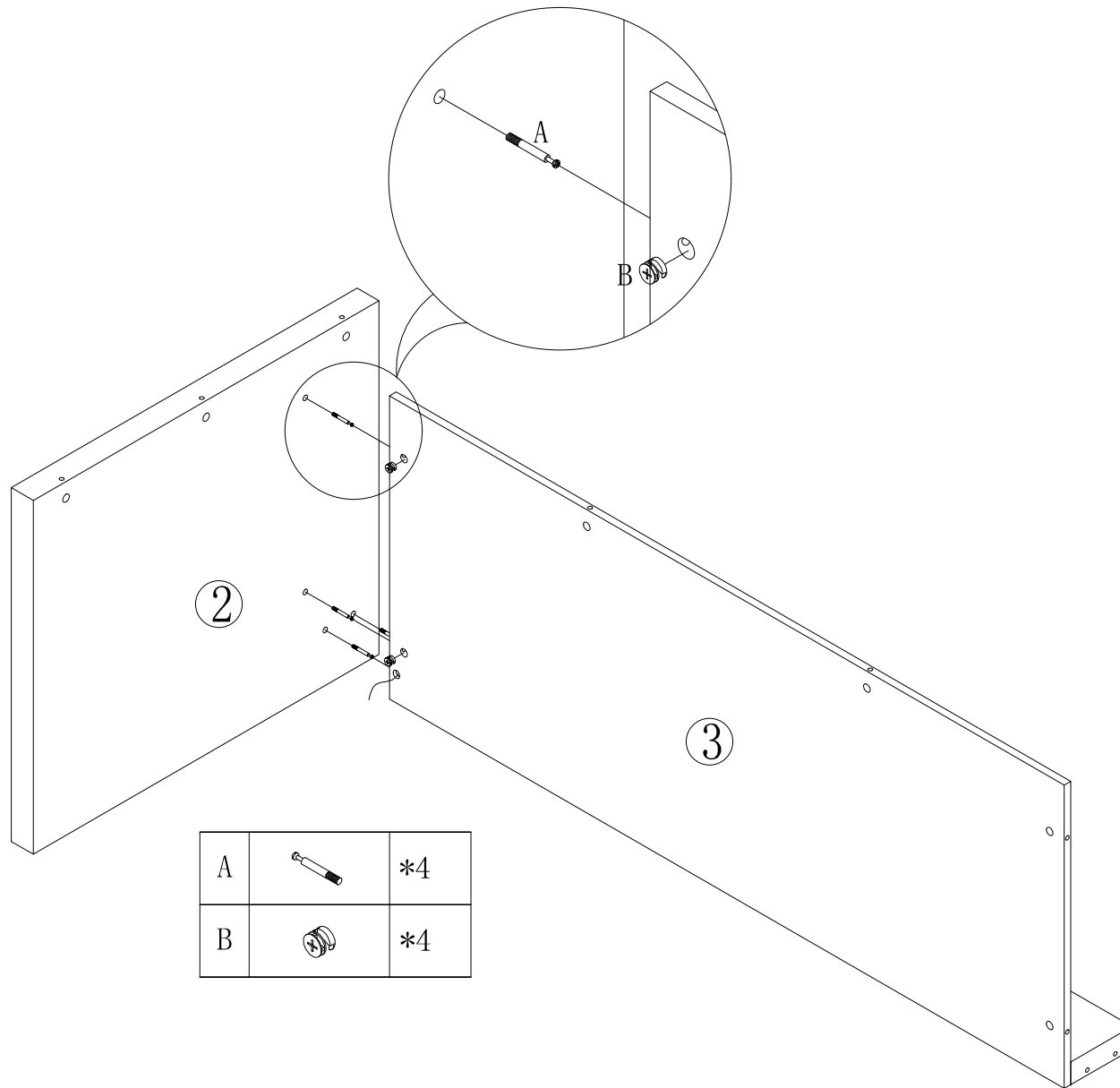

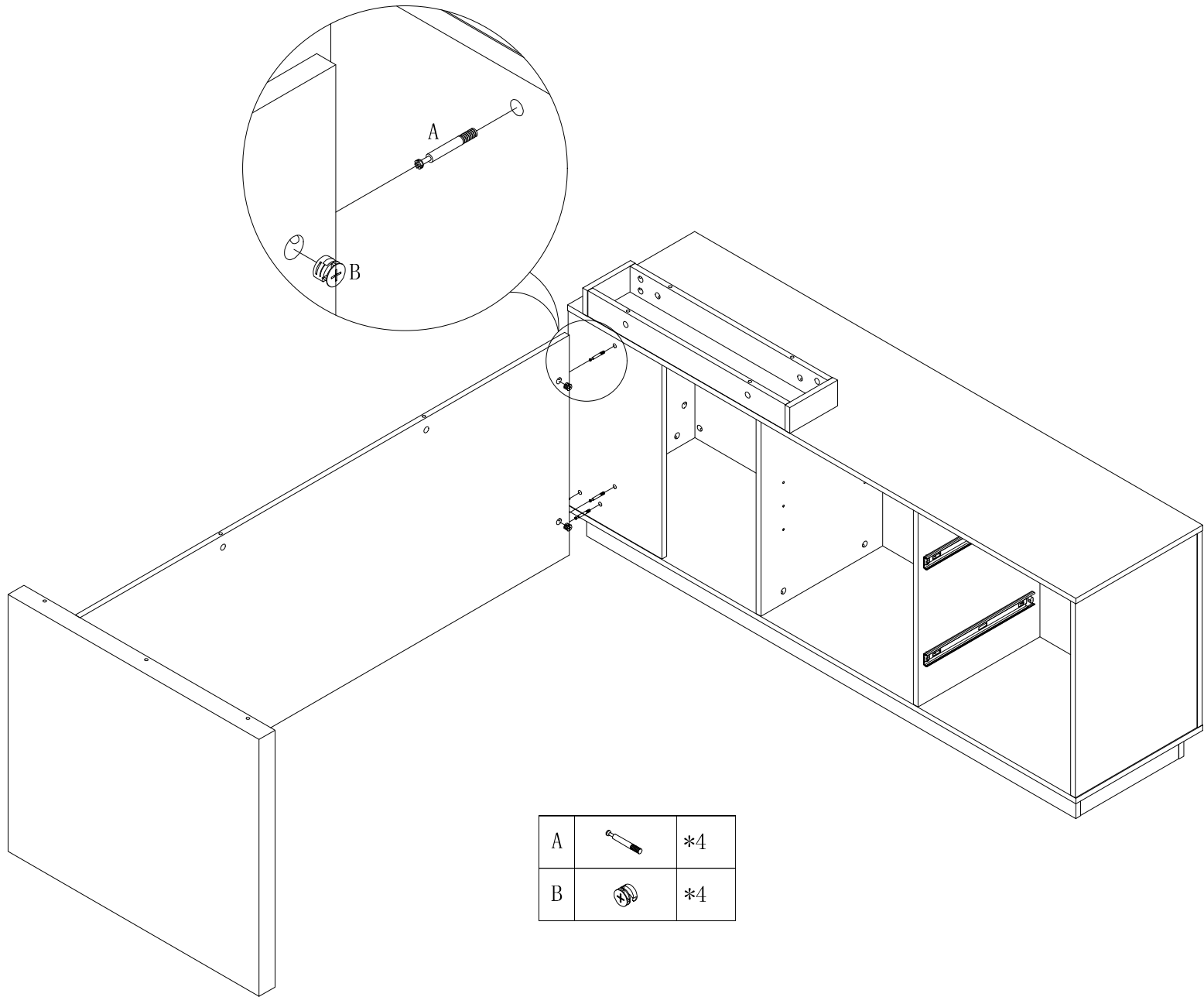

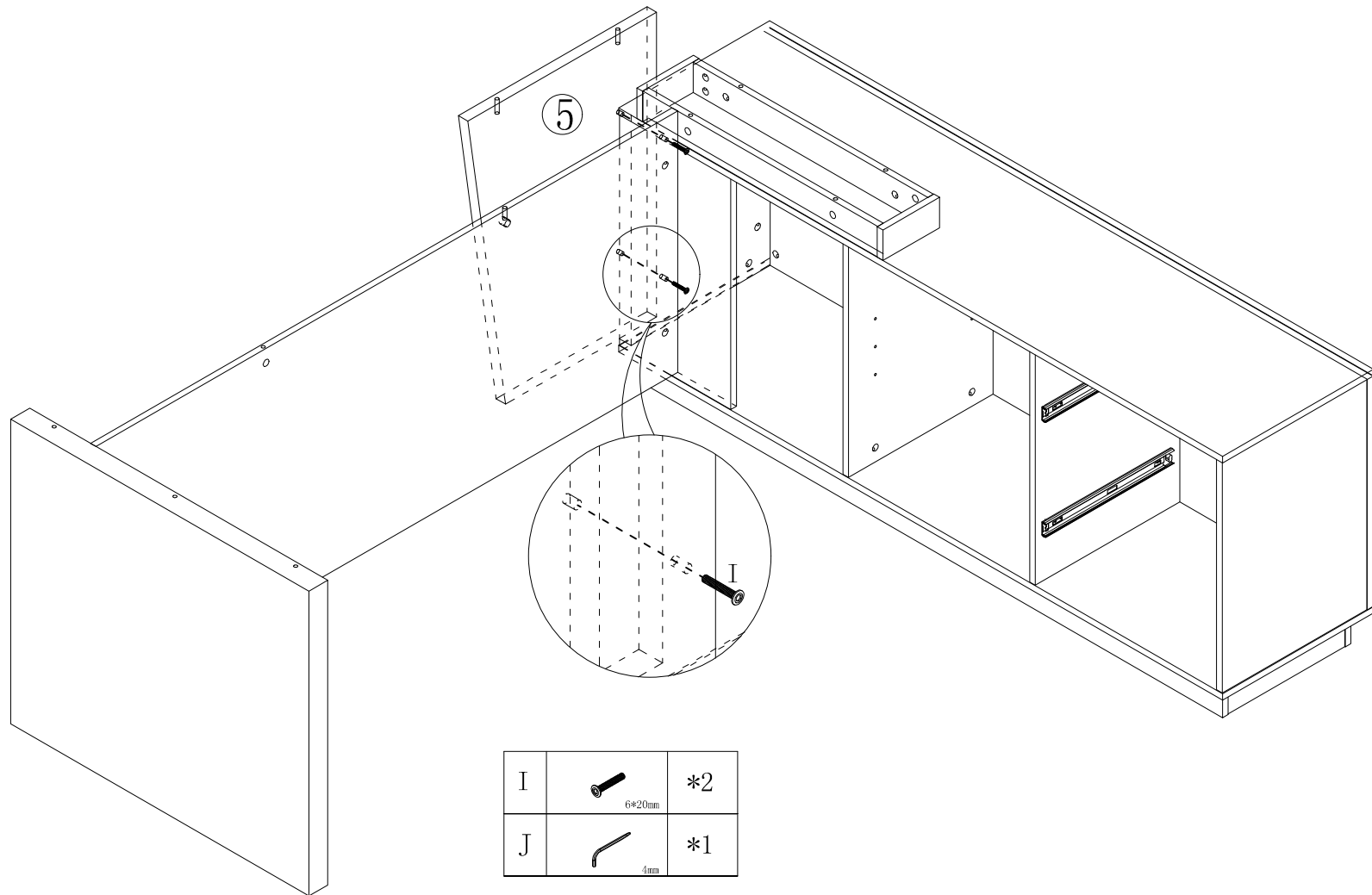

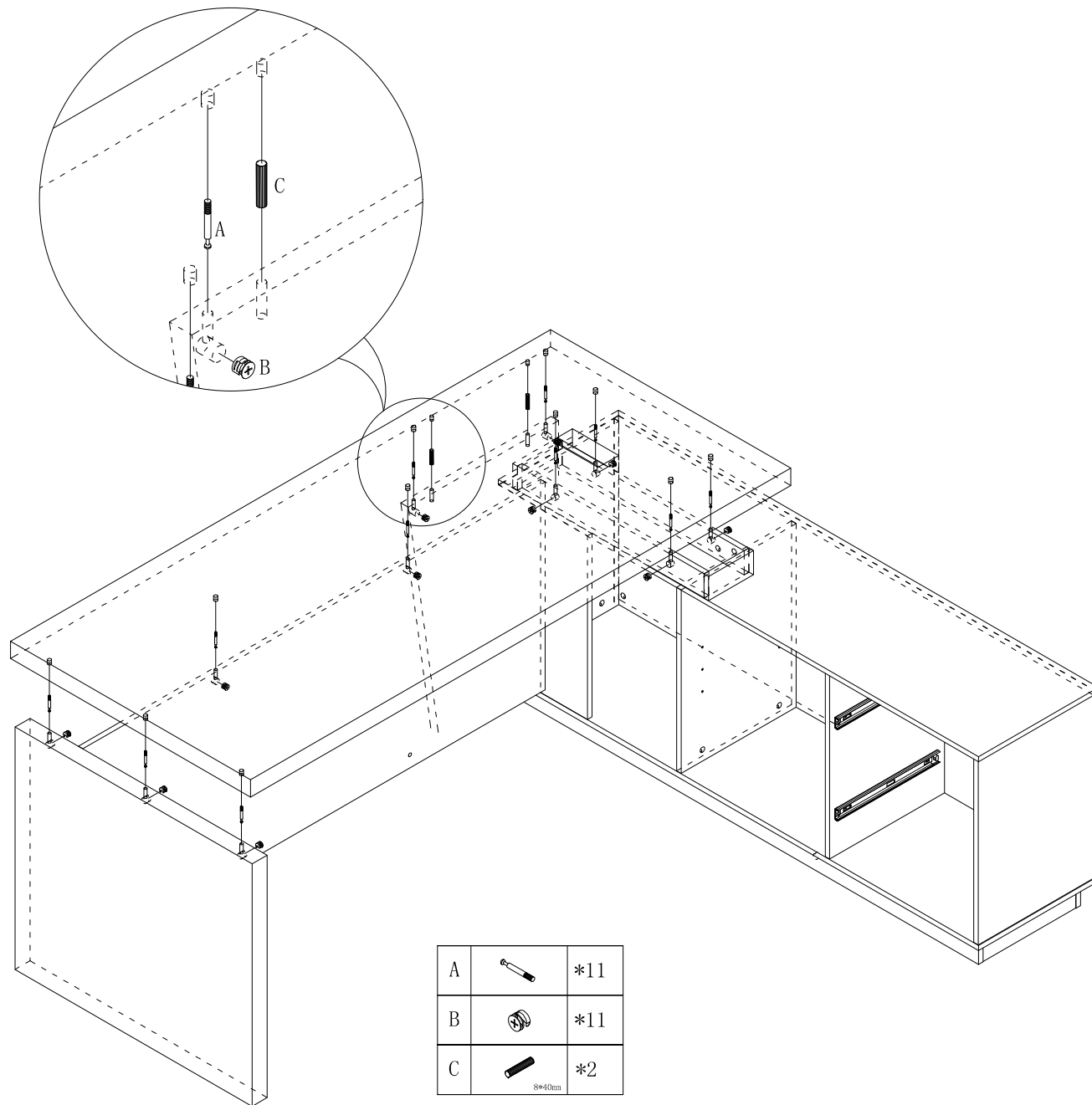







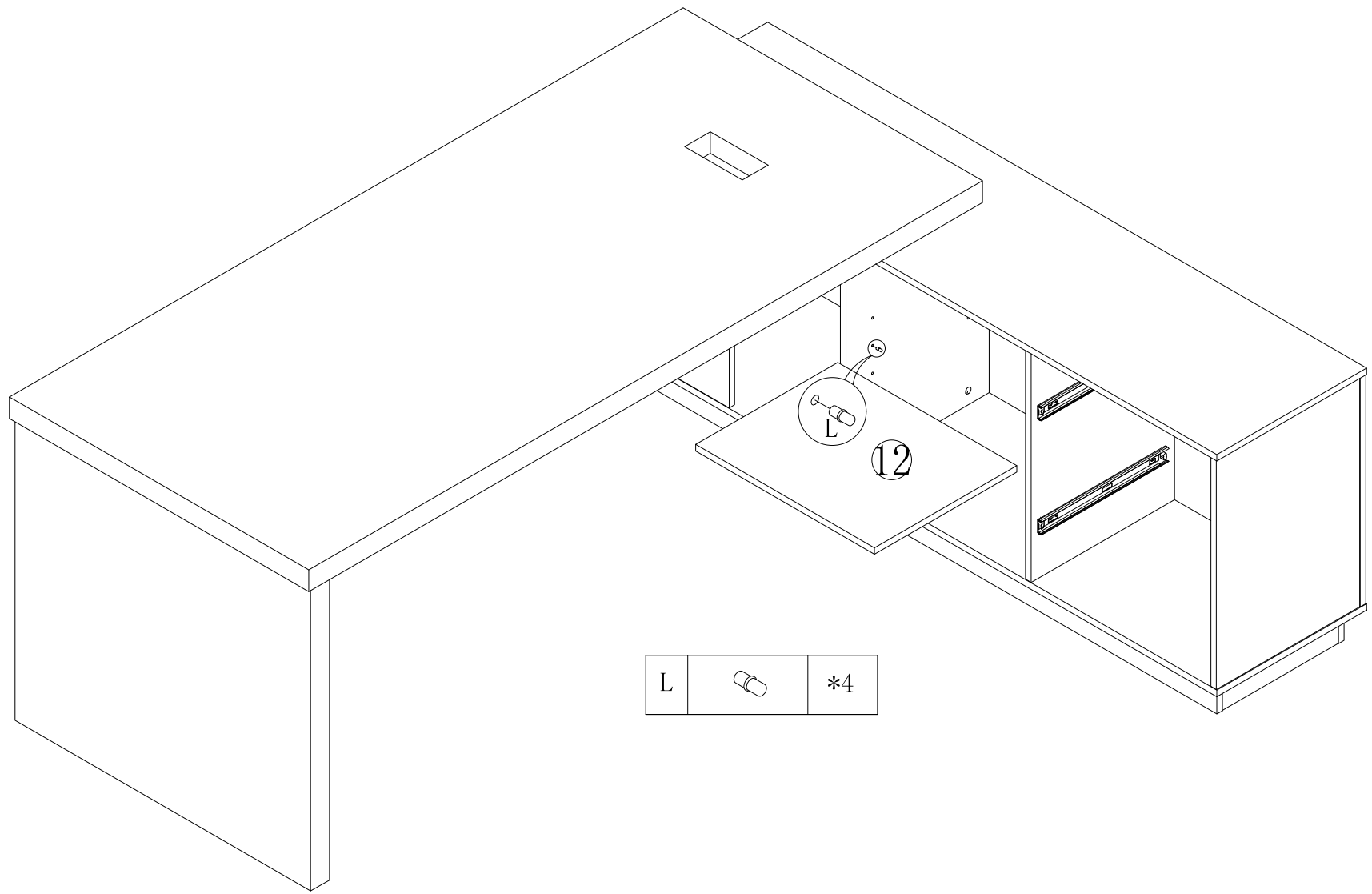

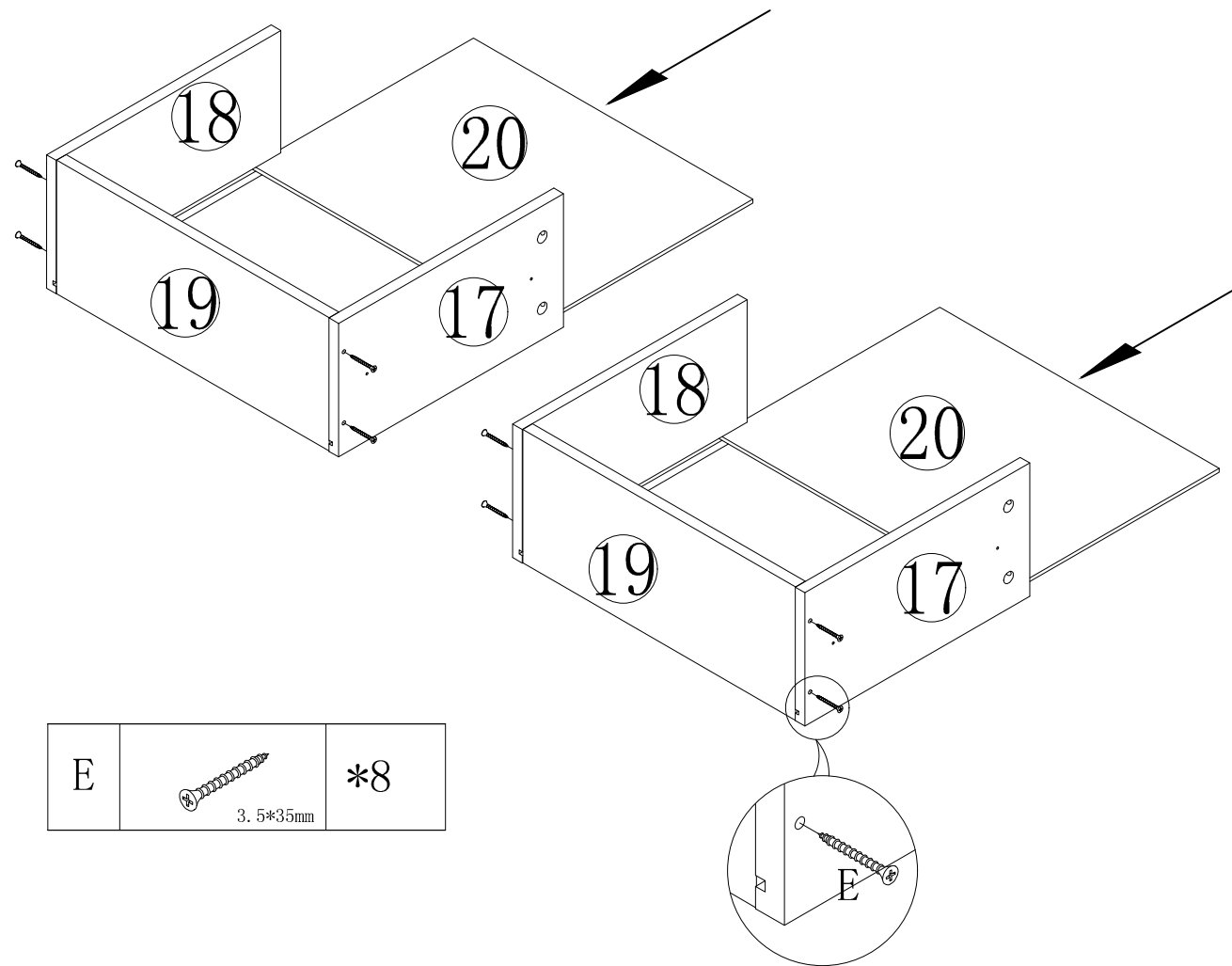

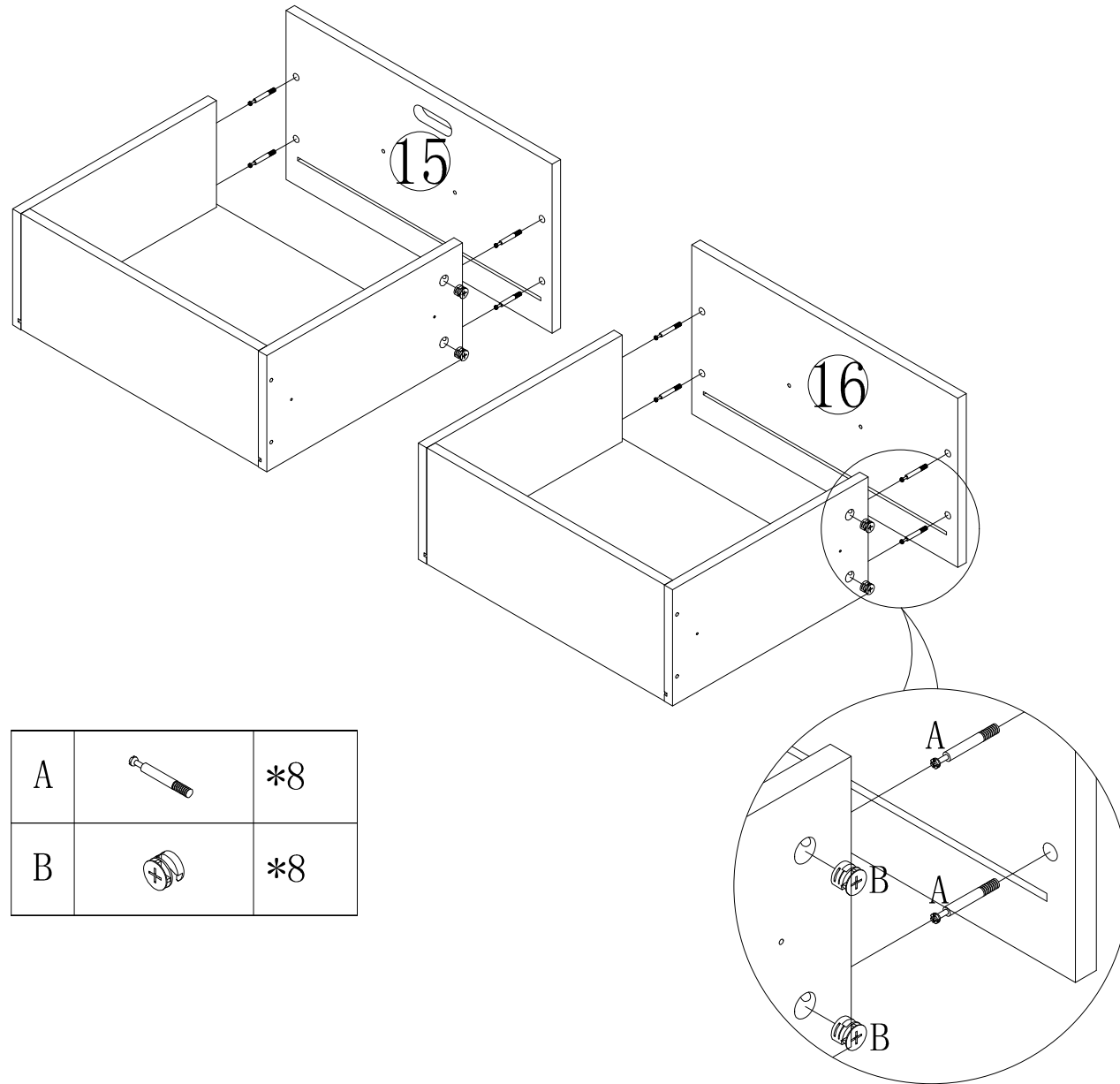
A		*11
B		*11
C	 ø=40mm	*2

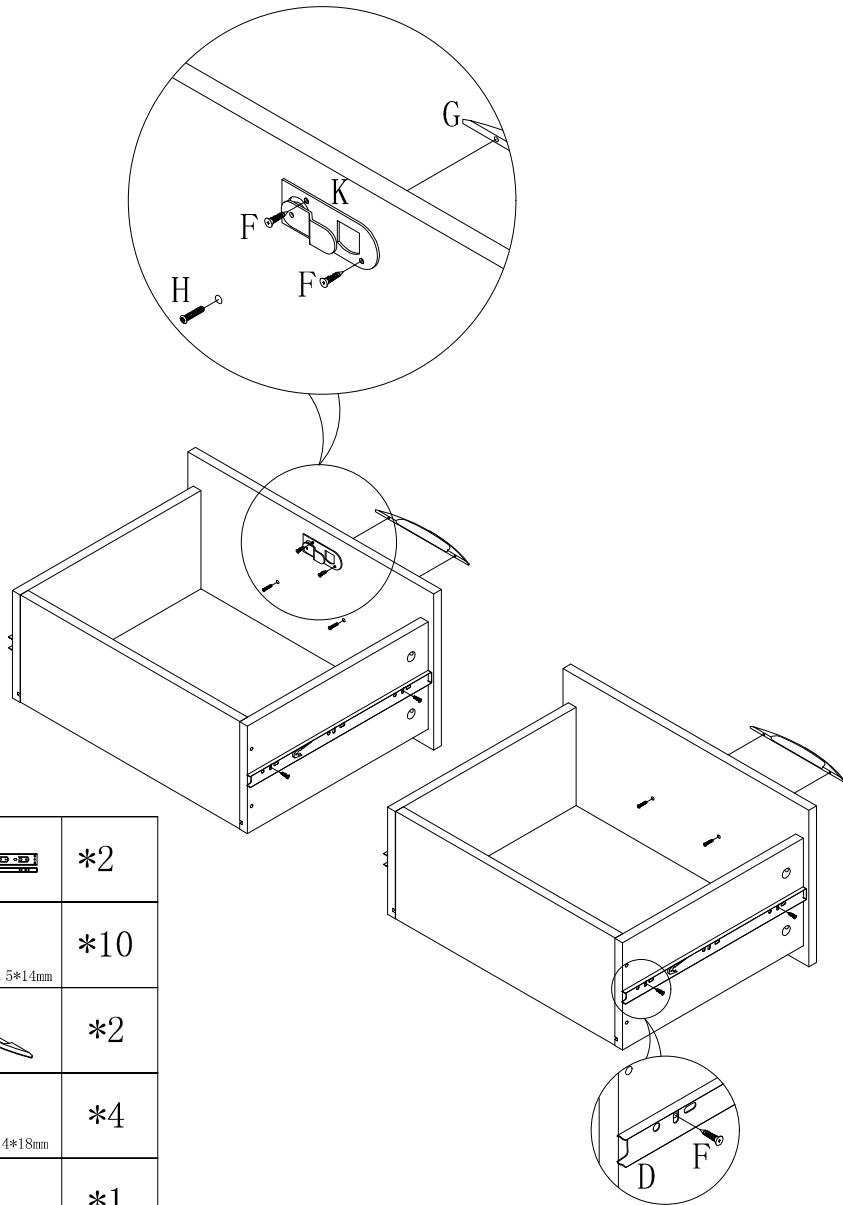







D	 *2
F	 3.5*14mm *10
G	 *2
H	 4*18mm *4
K	 *1

