

Seattle Side Table

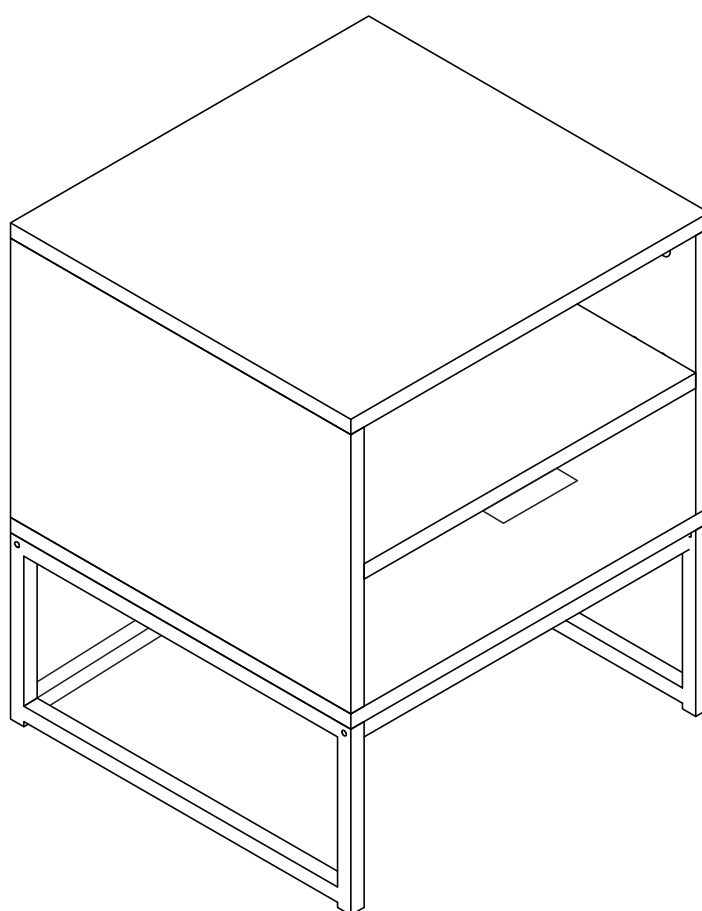

ASSEMBLY AND CARE GUIDE

45 MIN
ASSEMBLY TIME

2 PEOPLE
REQUIRED FOR ASSEMBLY

1 x 1 m
FLOOR SPACE REQUIRED

SAFETY PRECAUTIONS

PLEASE READ ALL INSTRUCTIONS CAREFULLY BEFORE ASSEMBLING AND USING THE PRODUCT.

1. Please check that all parts are present before you start the assembly of your furniture. A **Philips head screwdriver (not included)** is required for the assembled of this product.
2. For ease and speed of assembly, we recommend that before you commence each step of the assembly, that you identify all the parts required for that step.
3. For larger items, please ensure that you have sufficient space and people to assemble your product safely.
4. We recommend that, where possible, all items are assembled near to the area in which they will be placed in use, to avoid moving the product unnecessarily once assembled.
5. For the protection of your furniture, we recommend that the product is placed on a protected surface during assembly to prevent any damage.
6. During assembly, Do not tighten bolts / screws completely until all bolts / screws are lined up and inserted into holes, Do not over tighten screws and bolts to avoid stripping, Do not use power tools
7. Always place the product on a flat, steady and stable surface.
8. Do not stand on the product. Do not use the product as a stepladder.
9. This product is intended for indoor, household use only as it is a non industrial product.

CARE AND CLEANING

- Please periodically check all fittings and re-tighten as necessary.
- To clean your item, please use a damp cloth and wipe clean.
- Never allow any kind of liquid to remain on your furniture. If liquid spills onto the product, please wipe clean as soon as possible.

















**WARNING : ENSURE THE WALL STRAP IS ATTACHED TO
AVOID SERIOUS INJURY**

To avoid any serious or fatal injury, this product has been fitted with a wall strap to prevent toppling. We strongly recommend that this product is permanently fixed to the wall or other suitable surface. Fixing devices are not included since different surface materials require different attachments. Please seek professional advice if you are in doubt of what fixing device to use.

Do not stand on the product. Do not climb on the product. Do not swing on the product.

READ AND SAVE THESE INSTRUCTIONS FOR FUTURE REFERENCE

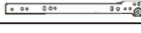
HARDWARE LIST

| | | | | |
|---|---|---------|--------------|-----|
| A |  | 6x35mm | Cam bolt | x12 |
| B |  | 15x10mm | Cam lock | x12 |
| C |  | 6x30mm | Wooden dowel | x12 |
| D |  | 4x35mm | Screw | x8 |
| E |  | | Handle | x1 |
| F |  | 3x12mm | Screw | x2 |
| G |  | 6x30mm | Bolt | x6 |
| H |  | 4x25mm | Screw | x8 |
| I |  | 3x12mm | Screw | x10 |
| J |  (L)  (R) | | Rail | x1 |
| K |  (L)  (R) | | Rail | x1 |
| L |  | | | x1 |

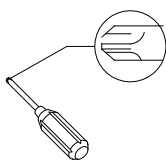

Philips head screwdriver required for assembly
(not included)

*The hardware quantities listed above are required for proper assembly.
Some extra hardware may also have been included.*

ASSEMBLY DIAGRAM

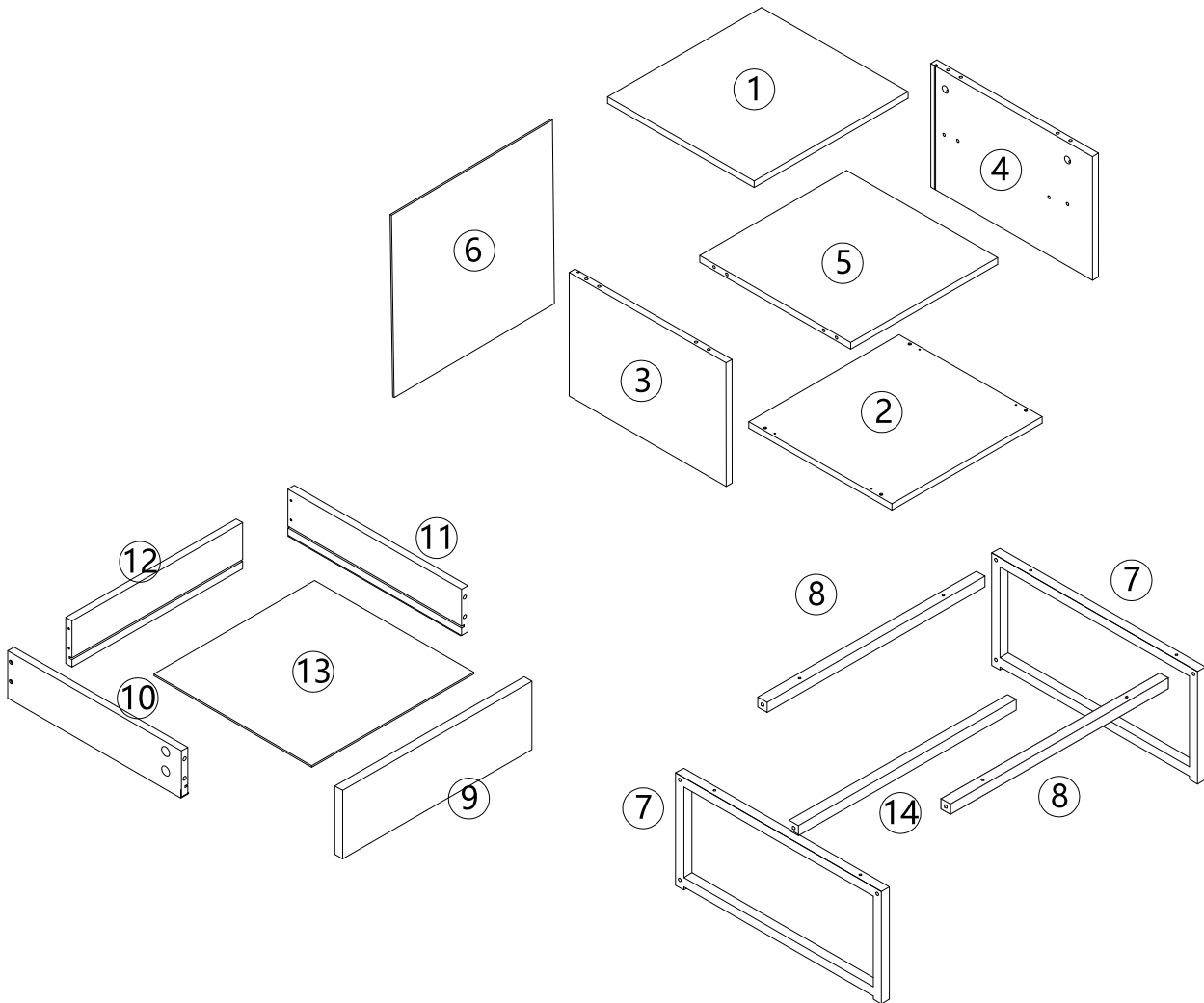

AFTER SALES SUPPORT

If you have any general enquiries or require spare parts for this product, please feel free to contact us via the following email:

Email: service@anmytek.com

You can contact us for support at any time. We'll answer you in 24hrs.

ASSEMBLY STEPS

STEP 1.

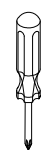
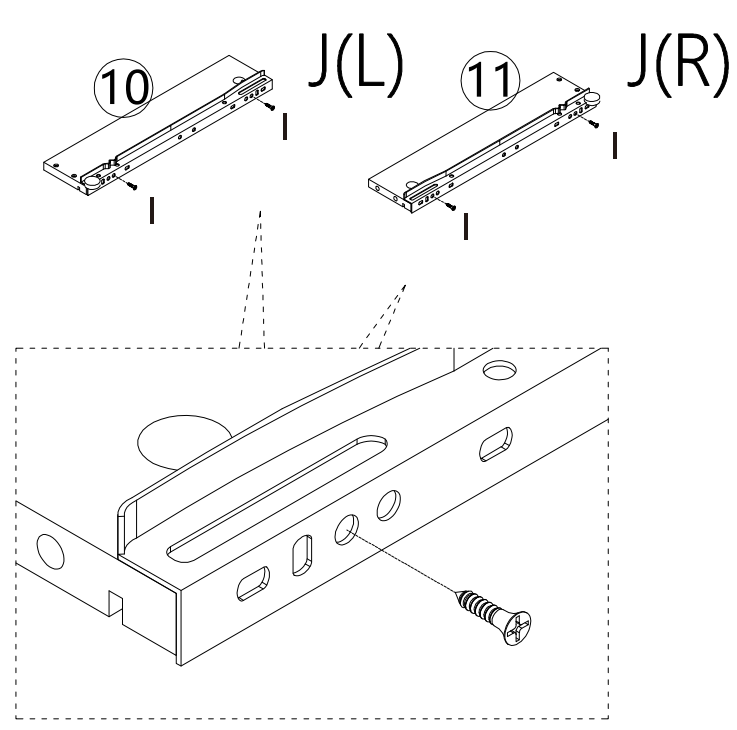
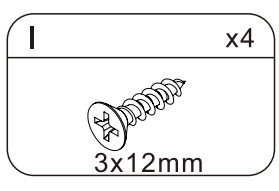
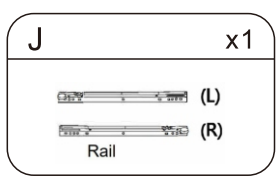

STEP 2.

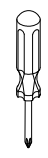
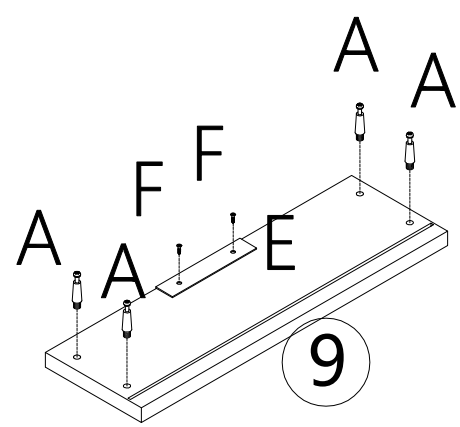
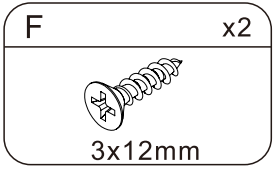
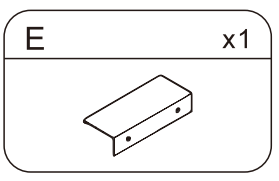
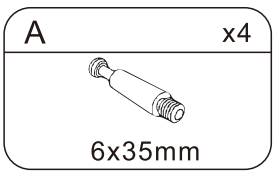

ASSEMBLY STEPS

STEP 3.

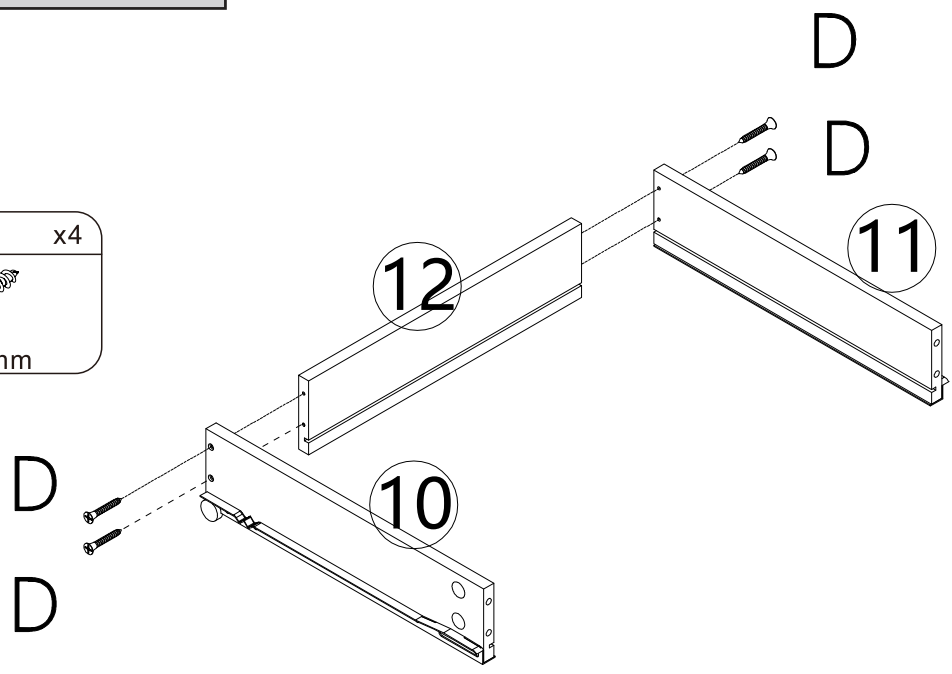
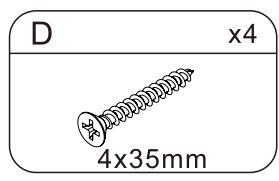

STEP 4.

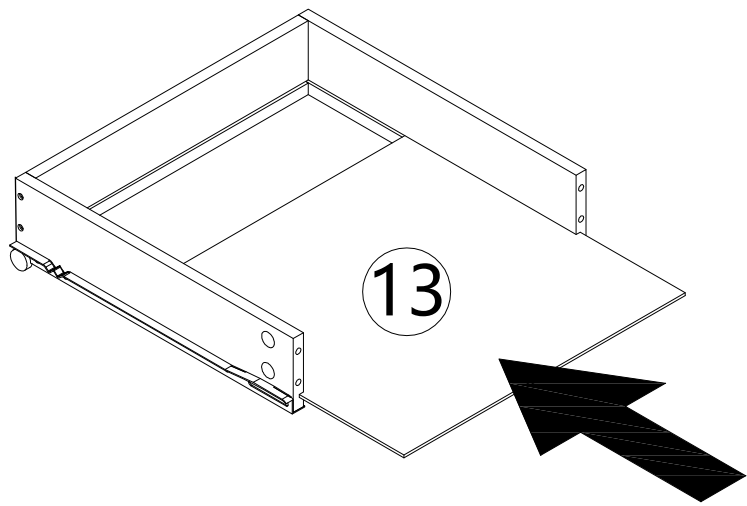

ASSEMBLY STEPS

STEP 5.

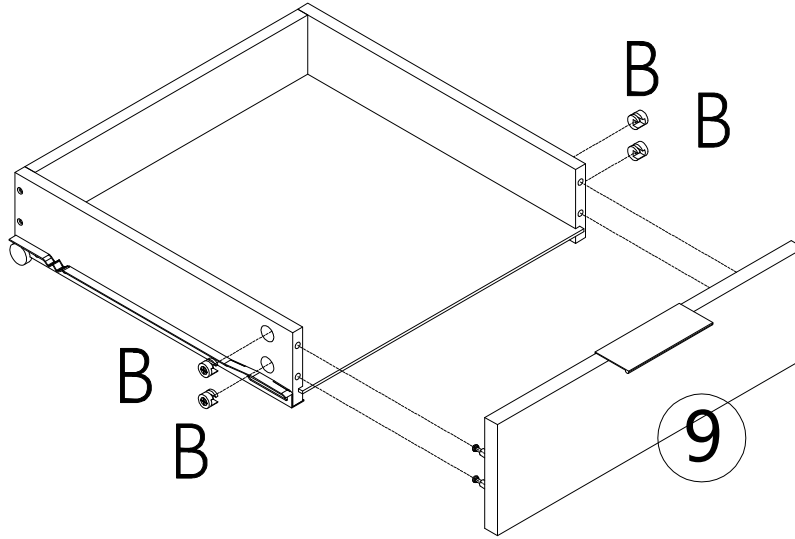
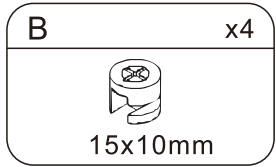

STEP 6.

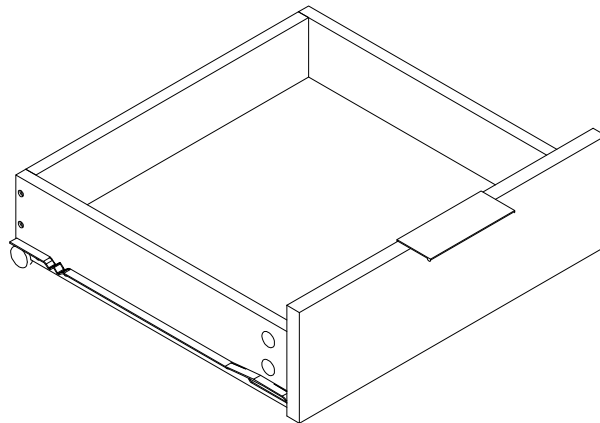

ASSEMBLY STEPS

STEP 7.

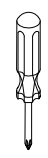
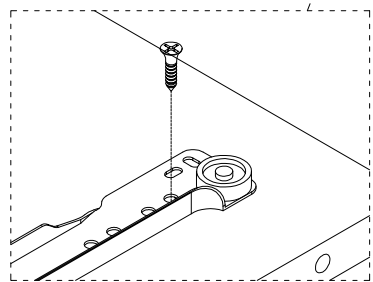
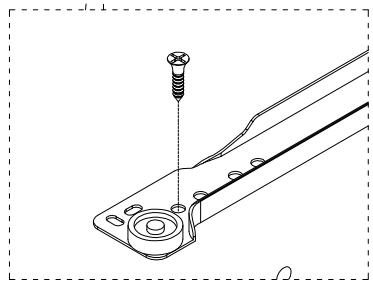
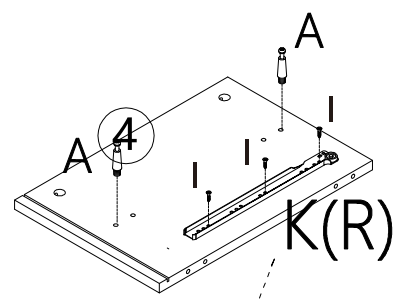
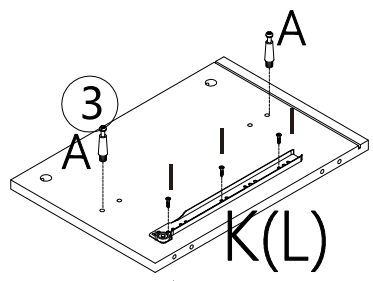
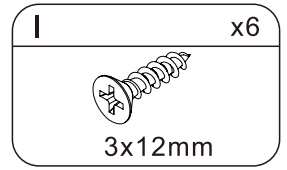
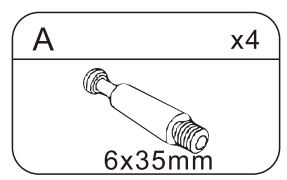
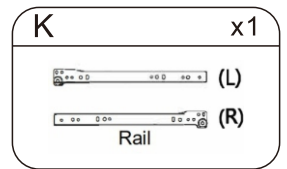

STEP 8.

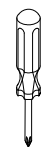
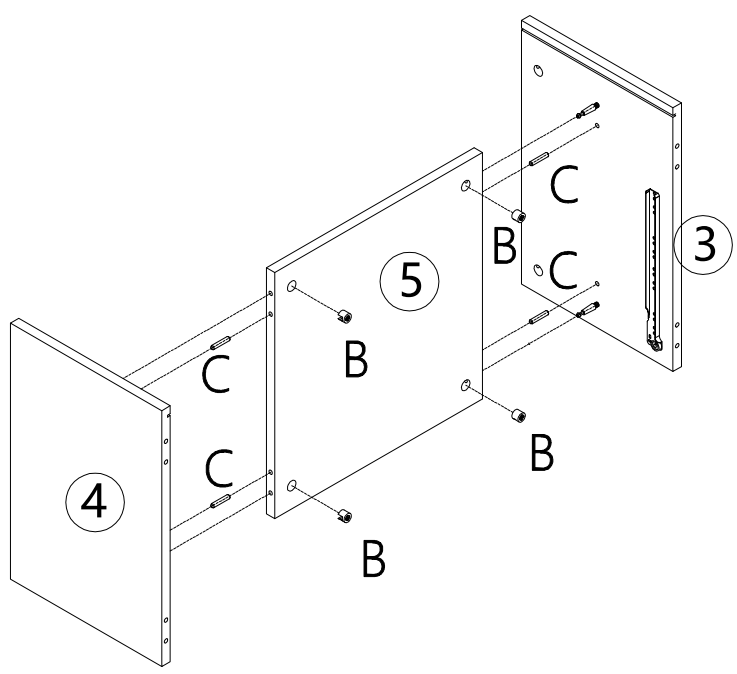
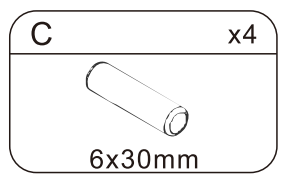
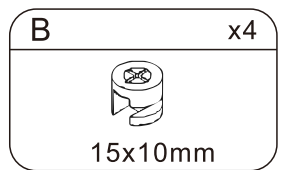

ASSEMBLY STEPS

STEP 9.

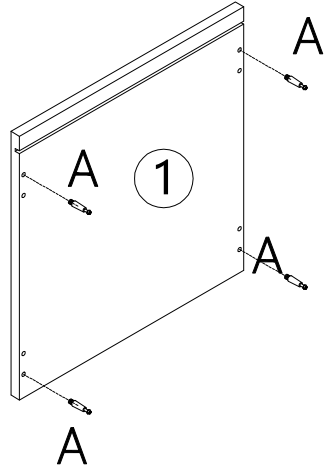
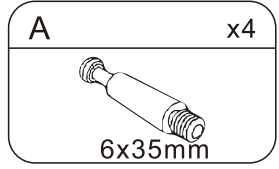

STEP 10.

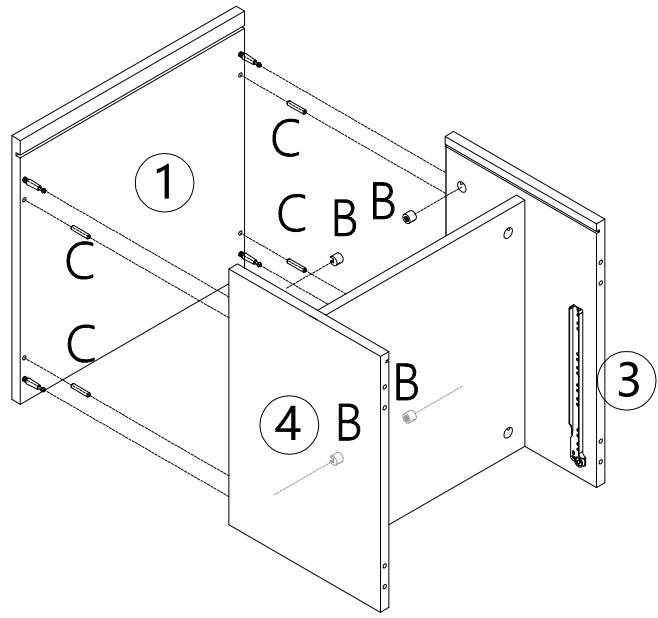
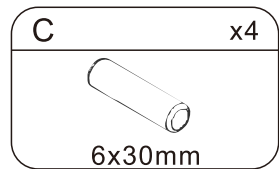
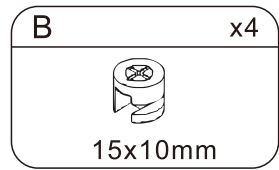
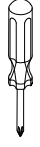

ASSEMBLY STEPS

STEP 11.

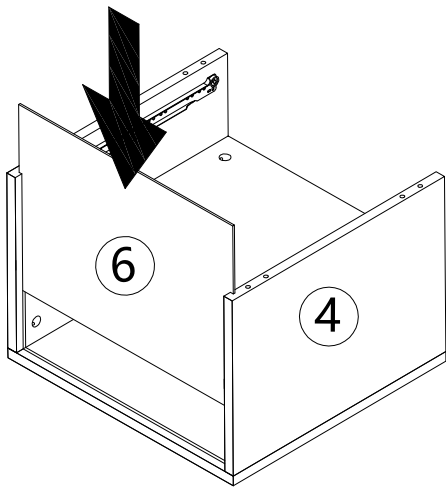

STEP 12.

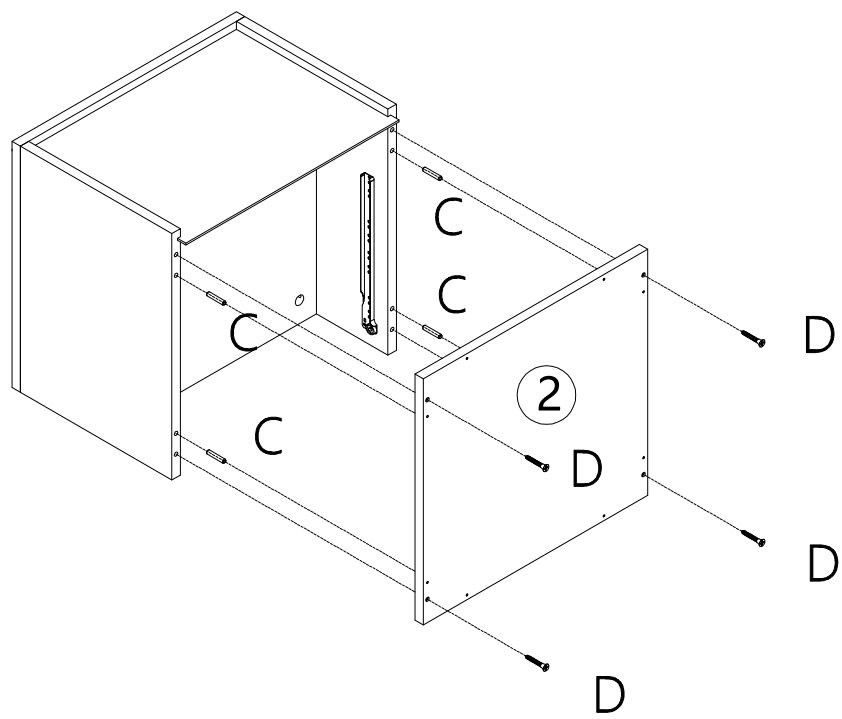
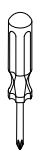
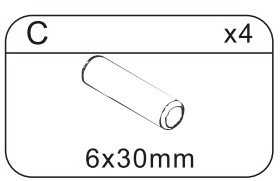
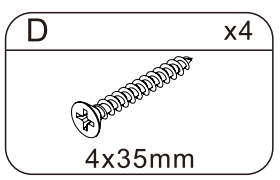

ASSEMBLY STEPS

STEP 13.

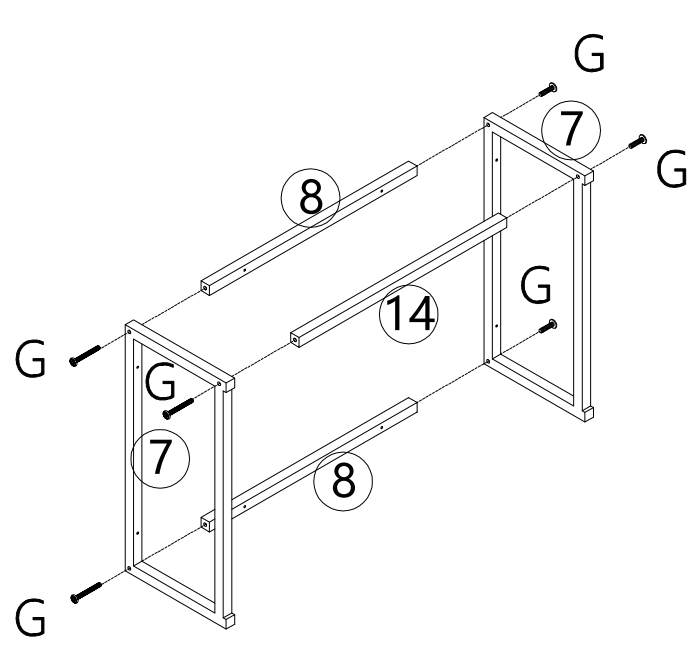
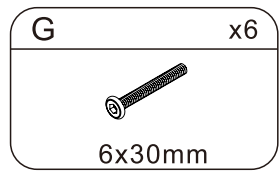

STEP 14.

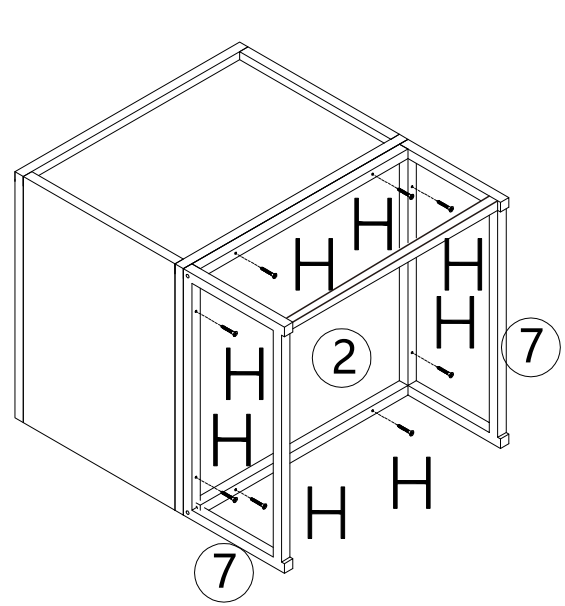
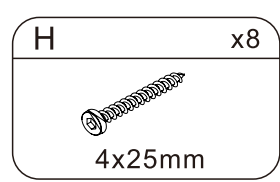

ASSEMBLY STEPS

