

Assembly Instructions

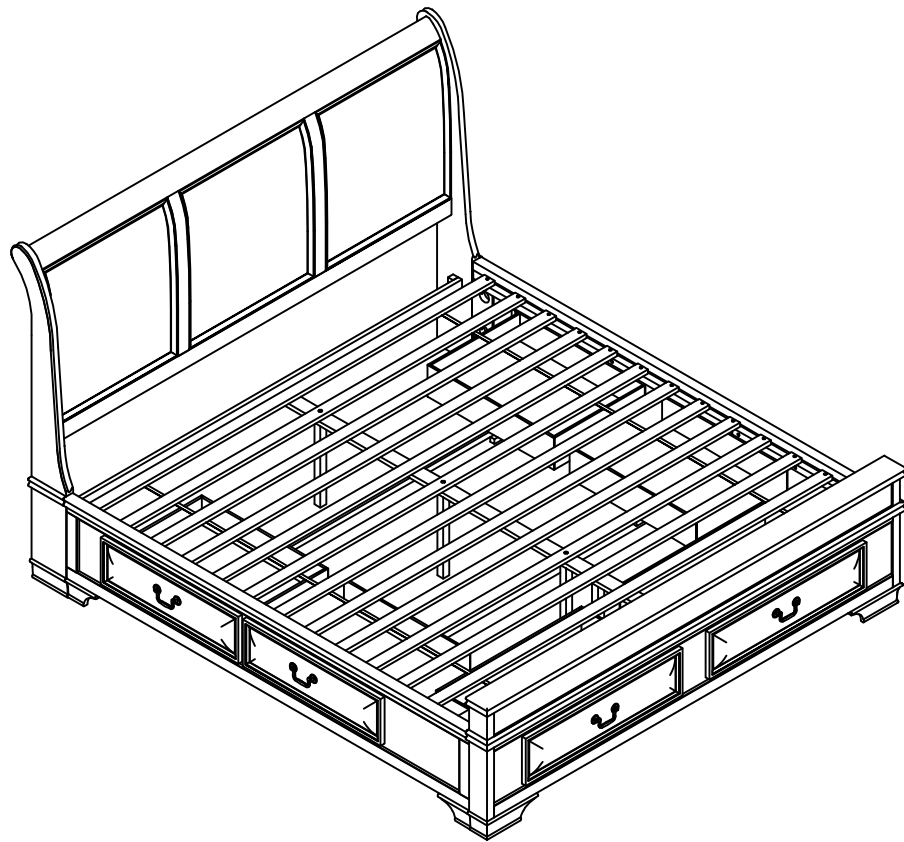

ASSEMBLY RATING

The Assembly Rating is a 5-point system that shows the degree of effort needed in assembling a specific product (with 1 being easy and 5 being difficult). For some products, two persons are recommended.

EASY



DIFFICULT

Tools Required For Assembly:

Allen Wrench

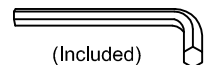

(Included)

Wrench

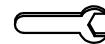

(Included)

Phillips Screwdriver

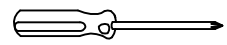

(Not Included)

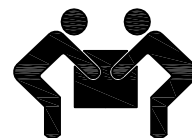

2 PERSONS RECOMMENDED

ASSEMBLY & CARE ADVICE

FOR YOUR FURNITURE TO LAST, CORRECT ASSEMBLY AND PROPER MAINTENANCE ARE NECESSARY. PLEASE FOLLOW THE INFORMATION PROVIDED BELOW TO FULLY ENJOY YOUR FURNITURE.

BASIC ASSEMBLY TECHNIQUES



When lock or spring washer is used in an assembly, please make sure the lock or spring washer is placed between the larger flat washer and the head of the screw or bolt.



Position each part correctly and insert screws or bolts into their respective holes by hand tighten or using the proper hand tool. Only tighten when step is completed or when instructed to do so.



Use cardboard or carpet area when assembling furniture to prevent scratches. Make sure the furniture rests on a flat and level surface with each leg evenly touching the floor.



Some furniture comes with height adjustment knobs underneath each leg. To lower or to raise each leg, you need to turn clockwise or counterclockwise, respectively.



Make sure all parts are properly aligned, then use the appropriate hand tool to completely tighten the bolts or screws. Do not use power tools and do not overtighten.



Save the instructions and store the Allen wrench or any supplied tool for later maintenance. After two weeks, check and tighten any loose hardware and repeat again every six months thereafter.

IT IS THE USER'S RESPONSIBILITY TO MAINTAIN THE FURNITURE. THE HARDWARE MAY LOOSEN OVER TIME AND MAY CAUSE THE FURNITURE TO BE WOBBLY AND UNABLE TO SUPPORT ITS INTENDED WEIGHT CAPACITY. THIS MAY LEAD TO COLLAPSE AND MAY CAUSE SERIOUS INJURY.





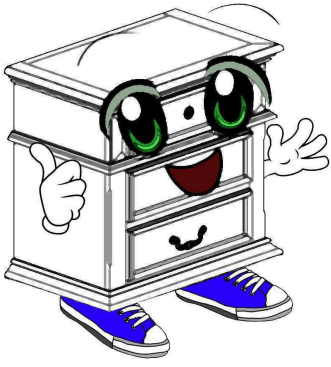

FAILURE TO FOLLOW THE GUIDELINES ABOVE MAY RESULT IN INJURY AND/OR PROPERTY DAMAGE.





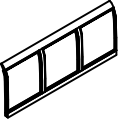

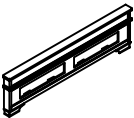
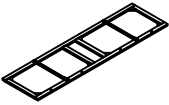
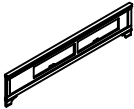

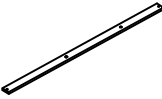
Before you begin, please read Page 2 of "Assembly and Care Advice".

And remember, do not tighten until each step is completed or instructed.

Parts List

	#1 x 1pc Headboard Panel
	#2 x 2pcs Headboard Leg (L&R)
	#3 x 1pc Headboard Support
	#4 x 1pc Storage Footboard
	#5 x 1pc Bottom Frame for drawer of Footboard
	#6 x 2pcs Side Rail (L&R)
	#7 x 2pcs Rail Drawer Support Slat
	#8 x 1pc Center Slat

Hardware List

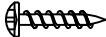
	#A x 8pcs Bolt Ø5/16" x 1-3/4"
	#B x 8pcs Lock Washer Ø5/16"
	#C x 8pcs Flat Washer Ø5/16"
	#D x 4pcs Bolt Ø1/4" x 1-1/2"
	#E x 4pcs Flat Washer Ø1/4"
	#F x 1pc Allen Wrench M4
	#G x 4pcs Wooden Dowel 10*40mm
	#H x 30pcs Screw #8 x 1-1/4"

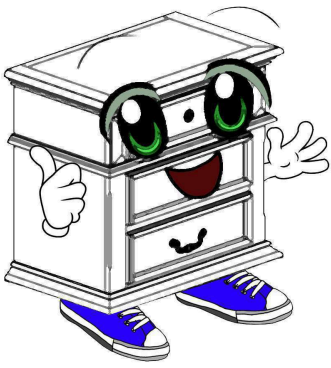

Before you begin, please read Page 2 of "Assembly and Care Advice".

And remember, do not tighten until each step is completed or instructed.

Parts List

Hardware List



#9 x 4pcs
Drawer for Side rail



#J x 8pcs
Threaded Stud $\text{Ø}5/16 \times 3-1/2$ "

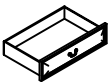

#10 x 2pcs
Drawer for Footboard



#K x 8pcs
Half Moon $\text{Ø}5/16$ "

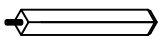

#11 x 3pcs
Long support leg 362x29x29mm



#L x 8pcs
Hex nut $\text{Ø}5/16$ "

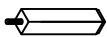

#12 x 2pcs
Short support leg 145x29x29mm

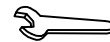

#M x 1pc
Wrench



#13 x 1pc
Storage Support Leg 195x29x29mm

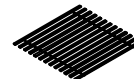

#14 x 1set
Bed Slat (13pcs)

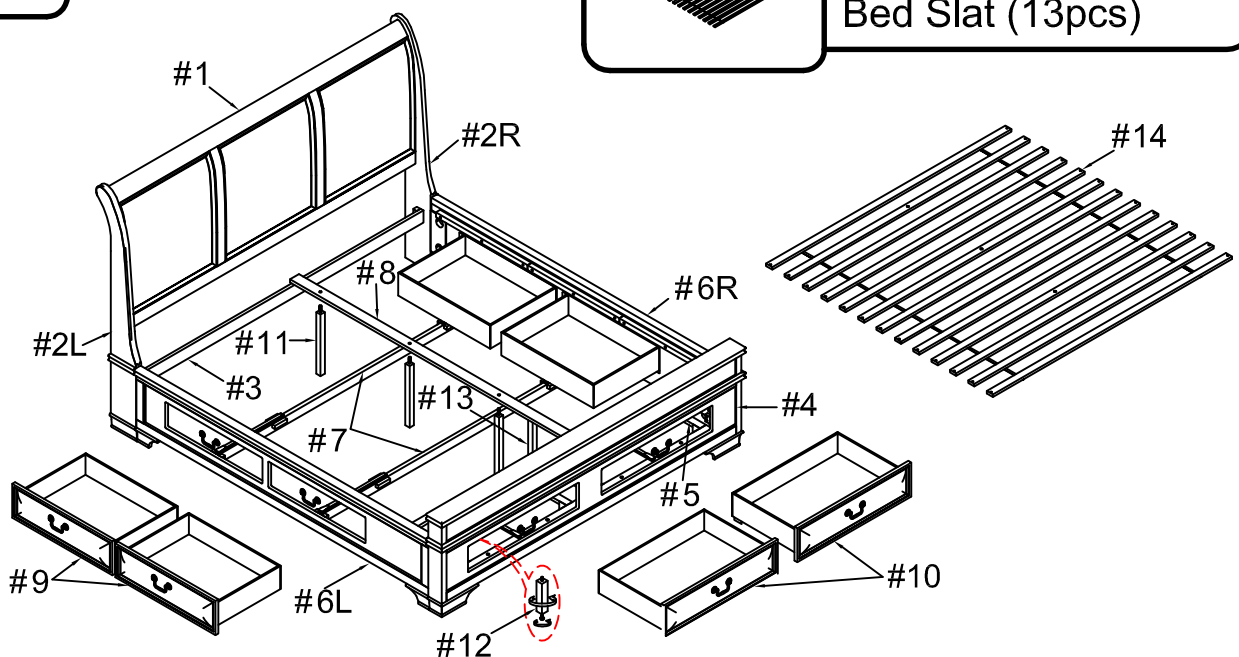



#1

#A x 8pcs
#B x 8pcs
#C x 8pcs
#G x 4pcs

Prepare 8 bolts assembly by inserting lock washer (#B), then flat washer (#C) onto bolts (#A). Attach dowels (#G) to the holes of the HB legs (#2R/L), then align HB legs (#2R/L) to the HB panel (#1) and HB support (#3). Secure by using bolts (#A).

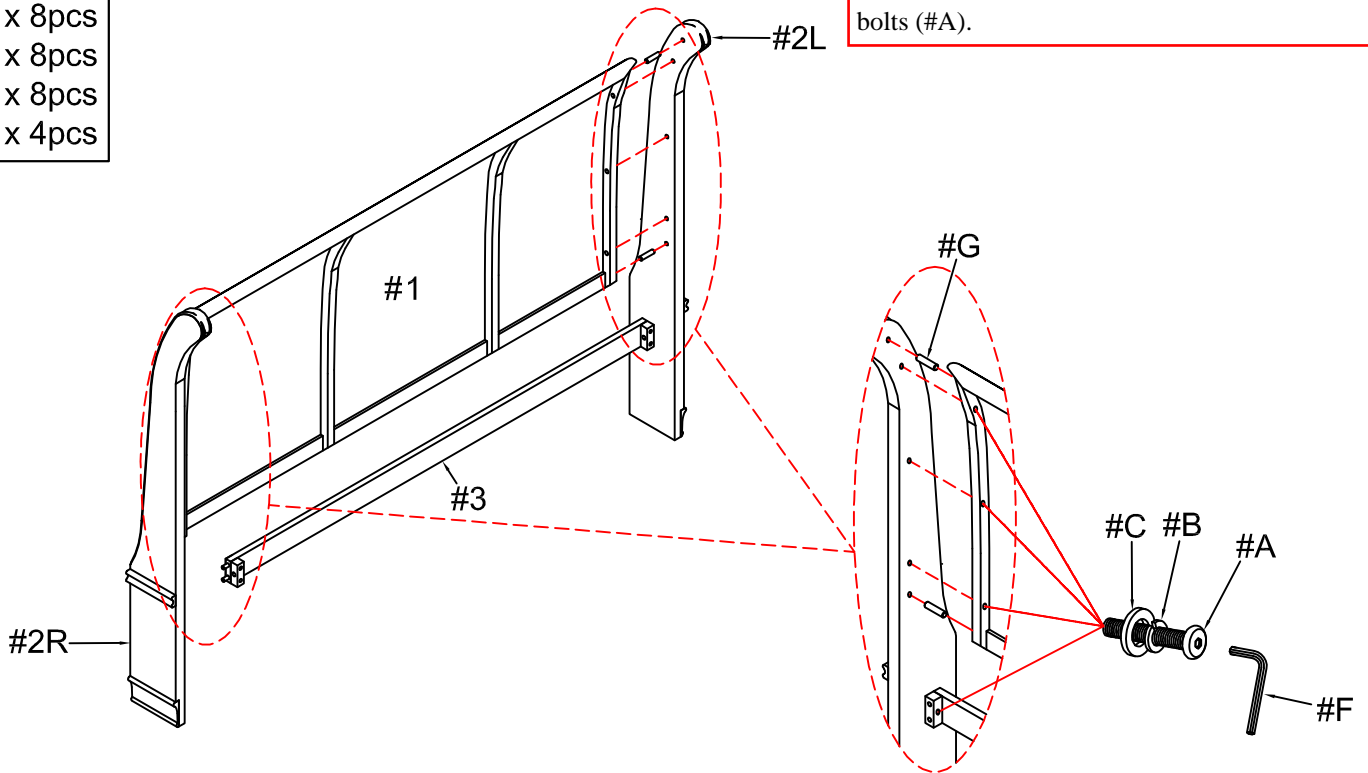

#2

#D x 4pcs
#E x 4pcs

2) Attach support legs (#13) to the holes of the bottom frame (#5).

1) Align bottom frame (#5) to the holes of the footboard (#4), then secure by using bolts (#D) with washers (#E).

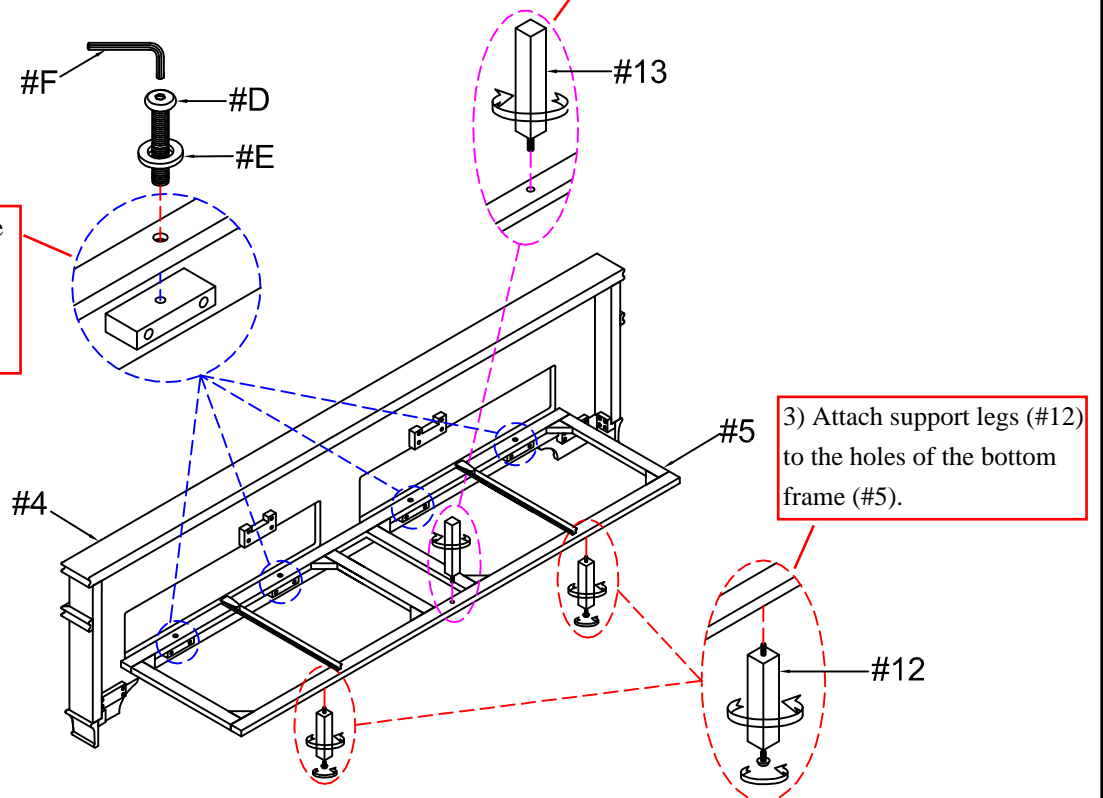

3) Attach support legs (#12) to the holes of the bottom frame (#5).



#3

Attach threaded studs (#J) to the holes of the headboard (#1) and footboard (#4), then align side rails (#6R/L) to the threaded studs (#J). Secure by using washer (#K) with hex nut (#L).

#J x 8pcs
#K x 8pcs
#L x 8pcs

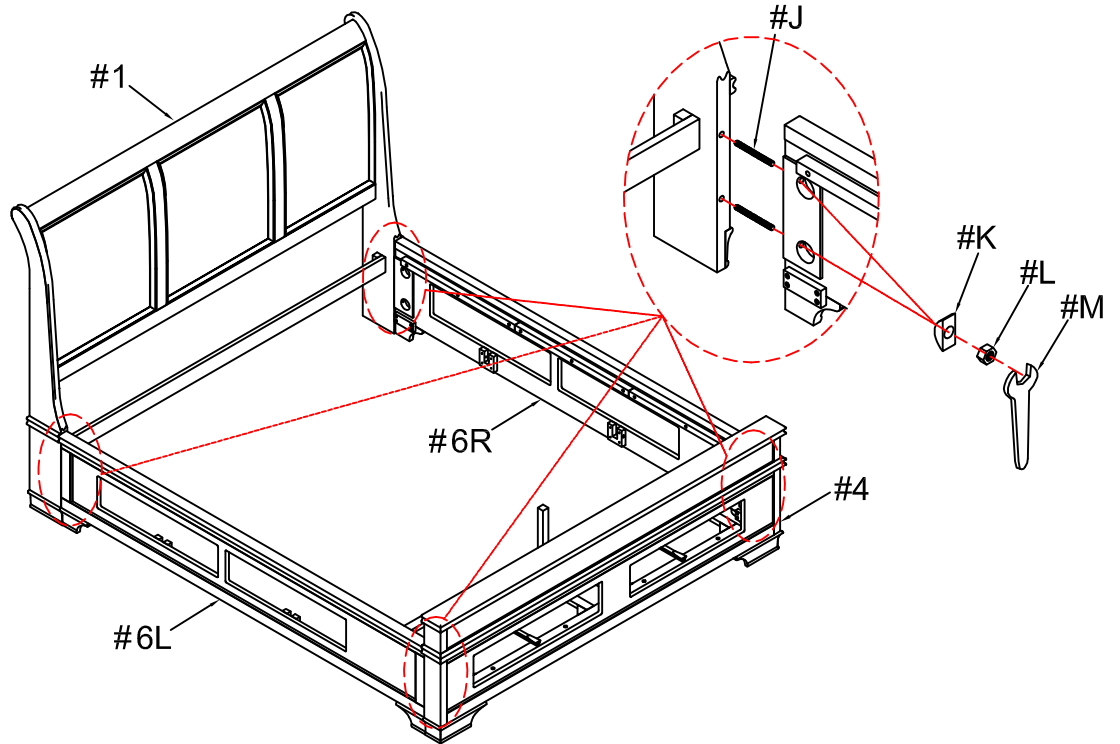

#4

Align rail drawer support slats (#7) to the side rails (#6R/L), then secure by using screws (#H).

#H x 4pcs

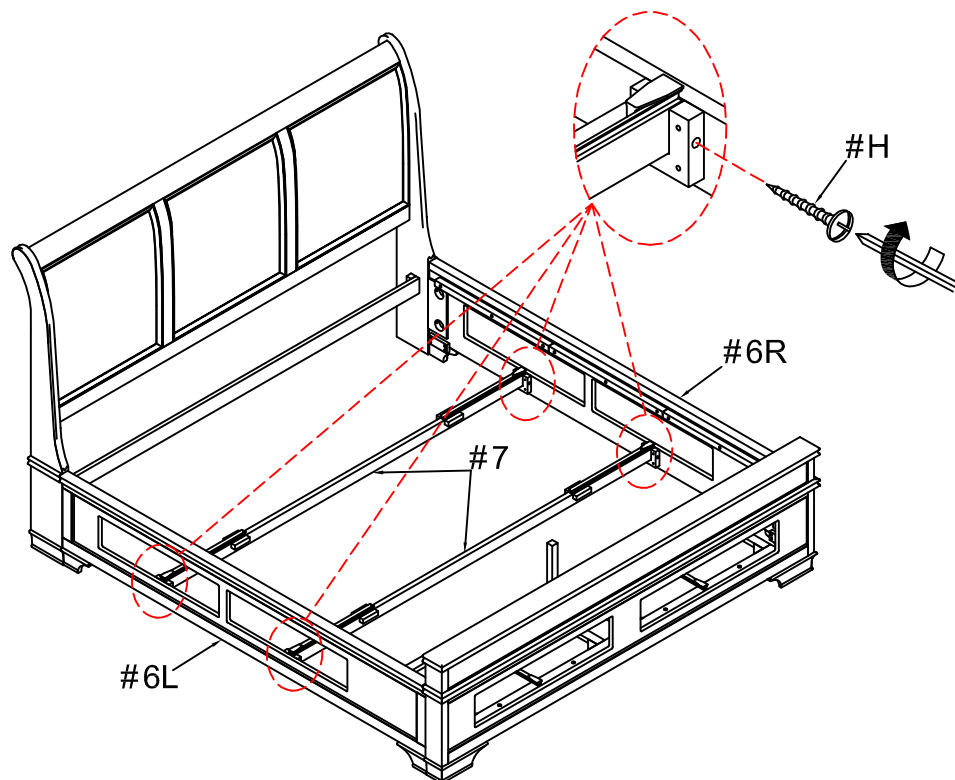



Align and attach support legs (#11) to the holes of the center slats (#8) and bed slats (#14).
Adjust the leveler on the support legs (#11) according to ground level.

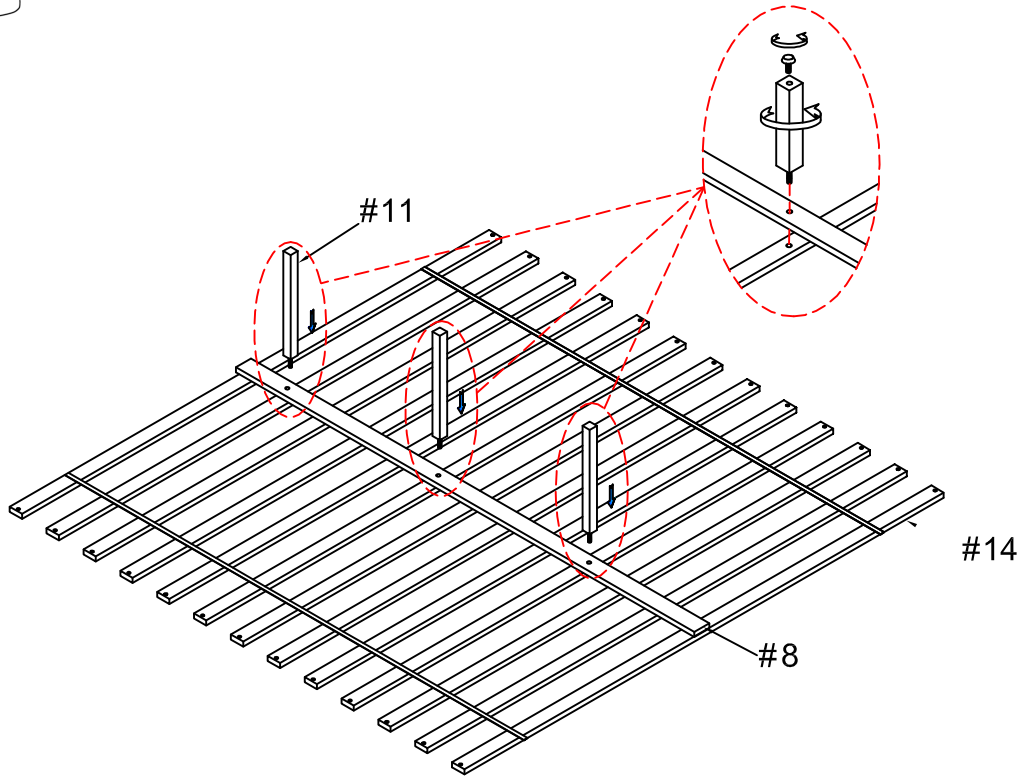

Place bed slats (#14) to the side rails, then secure by using screws (#H).

#H x 26pcs

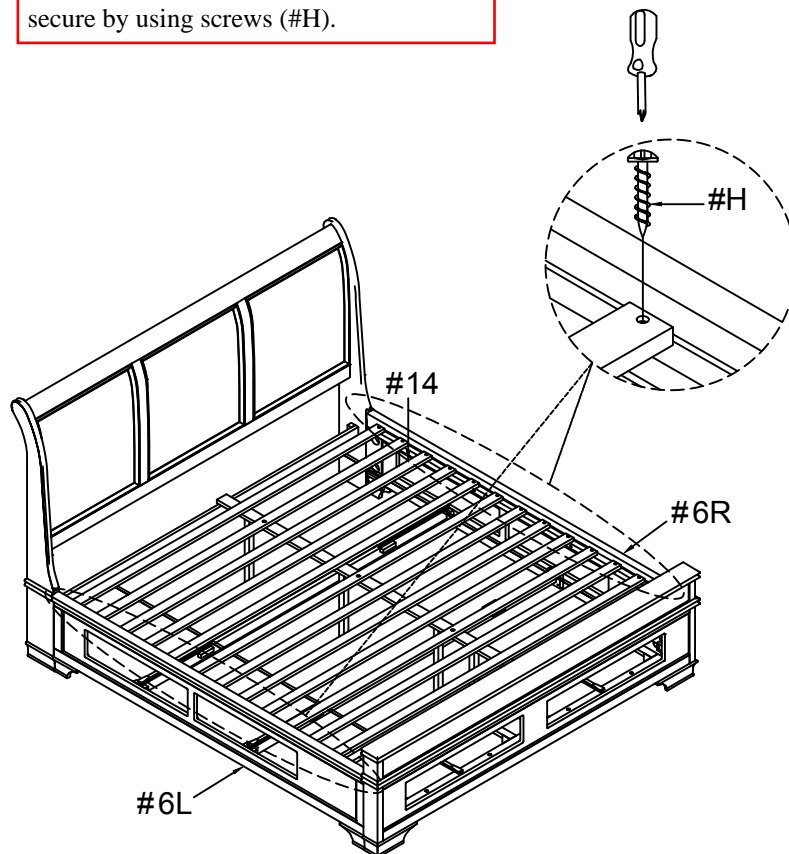



Attach drawers (#9,10) to the drawer slat rails.

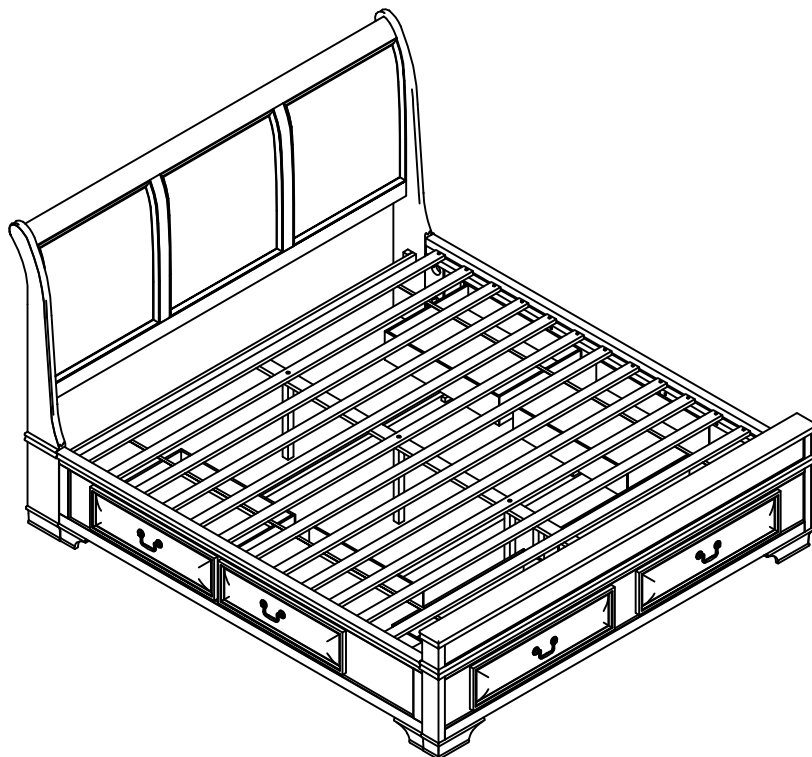
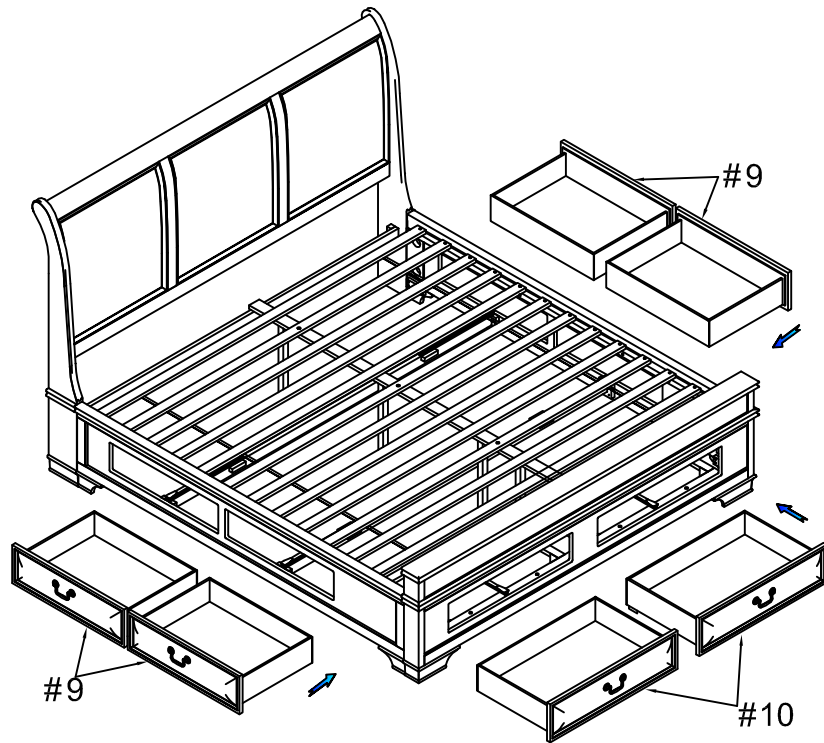

ASSEMBLY IS COMPLETED

Assembly Instructions

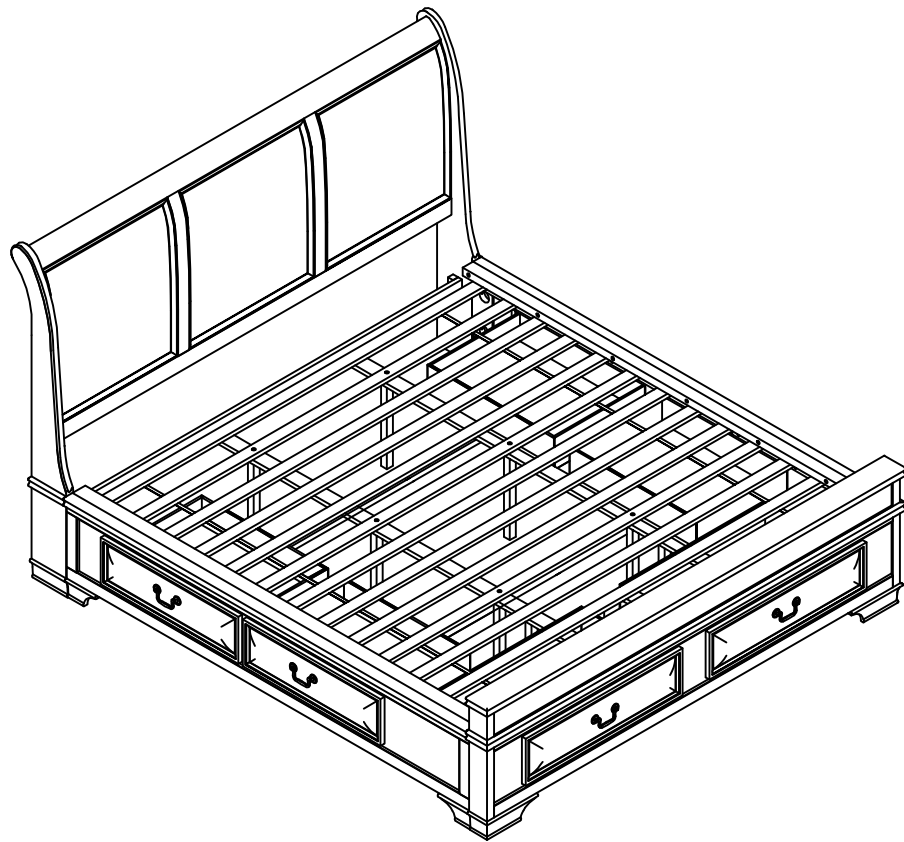

ASSEMBLY RATING

The Assembly Rating is a 5-point system that shows the degree of effort needed in assembling a specific product (with 1 being easy and 5 being difficult). For some products, two persons are recommended.

EASY  DIFFICULT

Tools Required For Assembly:

Allen Wrench

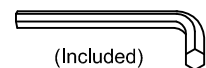

(Included)

Phillips Screwdriver



(Not Included)

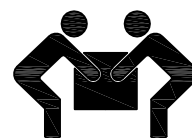

2 PERSONS RECOMMENDED

ASSEMBLY & CARE ADVICE

FOR YOUR FURNITURE TO LAST, CORRECT ASSEMBLY AND PROPER MAINTENANCE ARE NECESSARY. PLEASE FOLLOW THE INFORMATION PROVIDED BELOW TO FULLY ENJOY YOUR FURNITURE.

BASIC ASSEMBLY TECHNIQUES

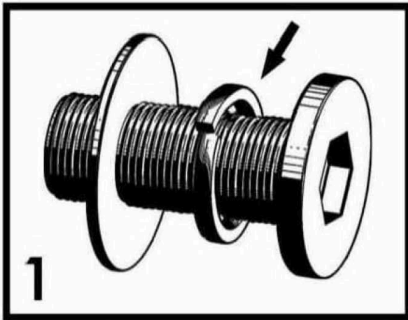

When lock or spring washer is used in an assembly, please make sure the lock or spring washer is placed between the larger flat washer and the head of the screw or bolt.

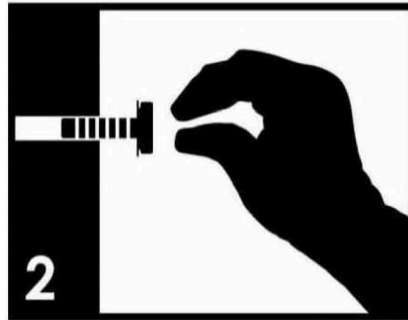

Position each part correctly and insert screws or bolts into their respective holes by hand tighten or using the proper hand tool. Only tighten when step is completed or when instructed to do so.

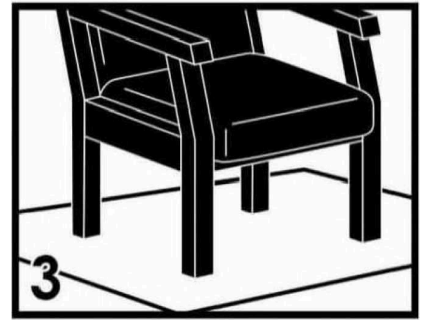

Use cardboard or carpet area when assembling furniture to prevent scratches. Make sure the furniture rests on a flat and level surface with each leg evenly touching the floor.

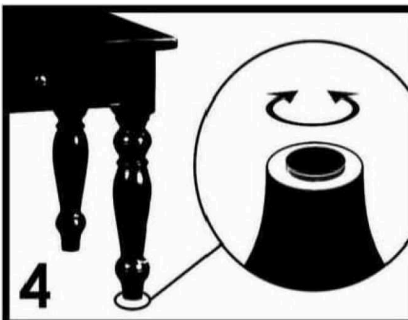

Some furniture comes with height adjustment knobs underneath each leg. To lower or to raise each leg, you need to turn clockwise or counterclockwise, respectively.

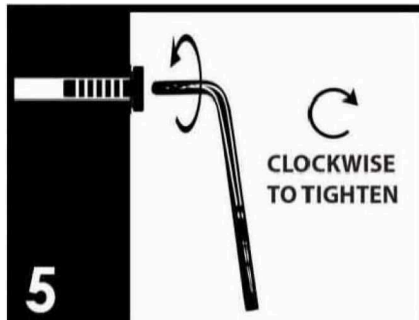

Make sure all parts are properly aligned, then use the appropriate hand tool to completely tighten the bolts or screws. Do not use power tools and do not overtighten.

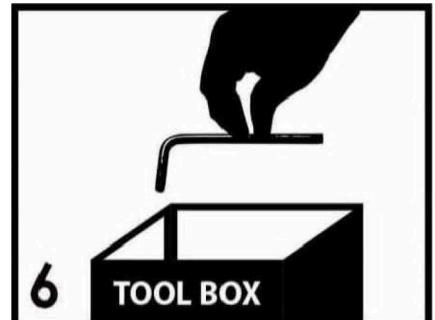

Save the instructions and store the Allen wrench or any supplied tool for later maintenance. After two weeks, check and tighten any loose hardware and repeat again every six months thereafter.

IT IS THE USER'S RESPONSIBILITY TO MAINTAIN THE FURNITURE. THE HARDWARE MAY LOOSEN OVER TIME AND MAY CAUSE THE FURNITURE TO BE WOBBLY AND UNABLE TO SUPPORT ITS INTENDED WEIGHT CAPACITY. THIS MAY LEAD TO COLLAPSE AND MAY CAUSE SERIOUS INJURY.

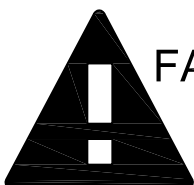

FAILURE TO FOLLOW THE GUIDELINES ABOVE MAY RESULT IN INJURY AND/OR PROPERTY DAMAGE.

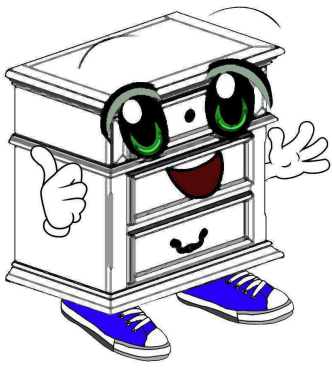

Before you begin, please read Page 2 of "Assembly and Care Advice".

And remember, do not tighten until each step is completed or instructed.

Parts List

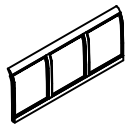

#1 x 1pc
Headboard Panel



#2 x 2pcs
Headboard Leg (L&R)



#3 x 1pc
Headboard Support

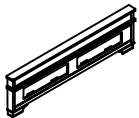

#4 x 1pc
Storage Footboard

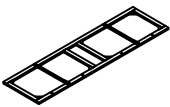

#5 x 1pc
Bottom Frame for drawer of Footboard

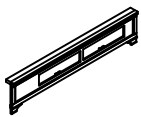

#6 x 2pcs
Side Rail (L&R)



#7 x 2pcs
Rail Drawer Support Slat

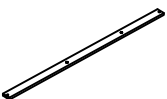

#8 x 2pcs
Center Slat

Hardware List



#A x 8pcs
Bolt $\text{Ø}5/16"$ x 1-3/4"



#B x 8pcs
Lock Washer $\text{Ø}5/16"$



#C x 8pcs
Flat Washer $\text{Ø}5/16"$



#D x 14pcs
Bolt $\text{Ø}1/4"$ x 1-1/2"



#E x 4pcs
Flat Washer $\text{Ø}1/4"$



#F x 1pc
Allen Wrench M4



#G x 4pcs
Wooden Dowel 10*40mm

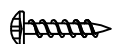

#H x 30pcs
Screw #8 x 1-1/4"

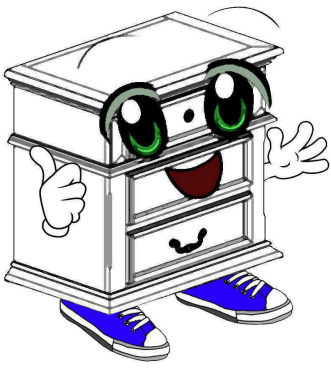

Before you begin, please read Page 2 of "Assembly and Care Advice".

And remember, do not tighten until each step is completed or instructed.

Parts List



#9 x 4pcs
Drawer for Side rail

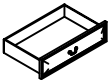

#10 x 2pcs
Drawer for Footboard

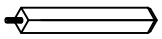

#11 x 6pcs
Long support leg 362x29x29mm

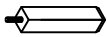

#12 x 2pcs
Short support leg 145x29x29mm



#13 x 2pcs
Storage Support Leg 195x29x29mm



#14 x 1set
Bed Slat (13pcs)

Hardware List



#J x 8pcs
Threaded Stud Ø5/16"x3-1/2"



#K x 8pcs
Half Moon Ø5/16"



#L x 8pcs
Hex nut Ø5/16"

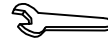

#M x 1pc
Wrench

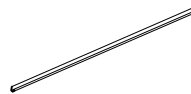

#15 x 2pcs
Top Side Rail

Exploded View

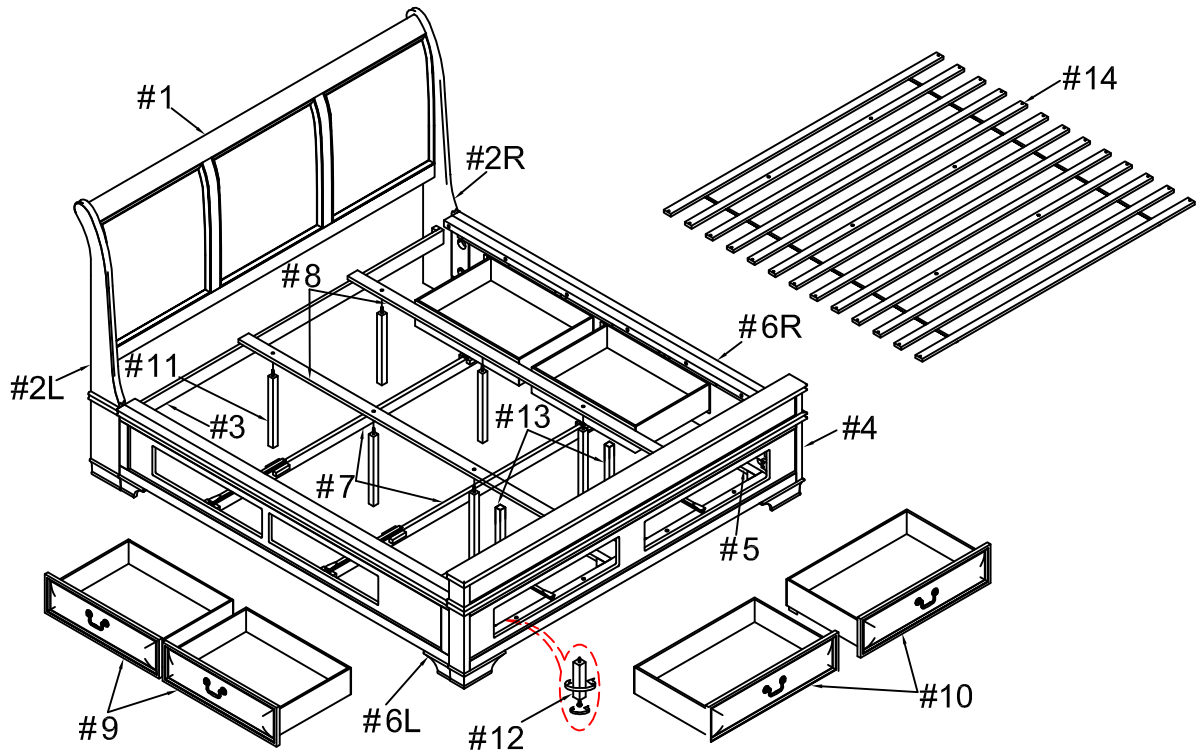

- #A x 8pcs
- #B x 8pcs
- #C x 8pcs
- #G x 4pcs

Prepare 8 bolts assembly by inserting lock washer (#B), then flat washer (#C) onto bolts (#A). Attach dowels (#G) to the holes of the HB legs (#2R/L), then align HB legs (#2R/L) to the HB panel (#1) and HB support (#3). Secure by using bolts (#A).

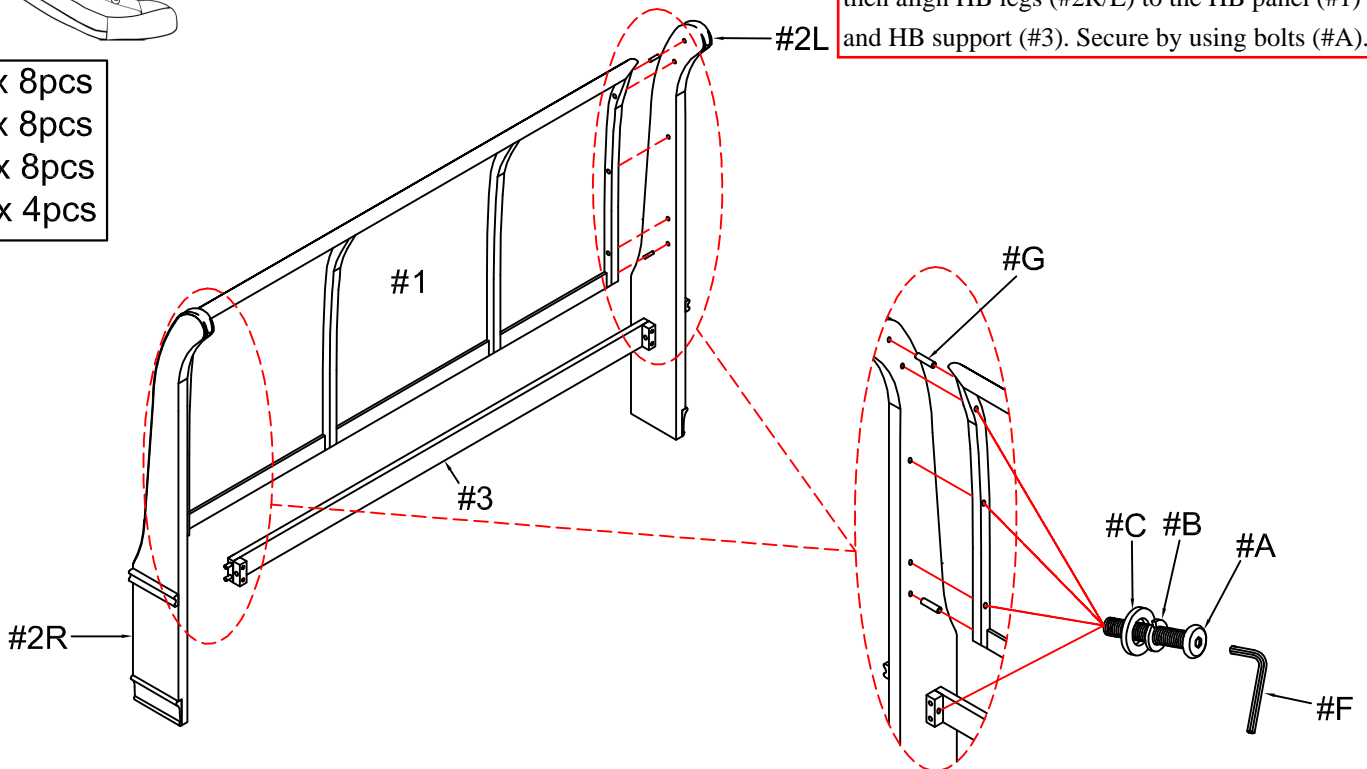



#2

#D x 4pcs
#E x 4pcs

1) Align bottom frame (#5) to the holes of the footboard (#4), then secure by using bolts (#D) with washers (#E).

2) Attach support legs (#13) to the holes of the bottom frame (#5).

3) Attach support legs (#12) to the holes of the bottom frame (#5).

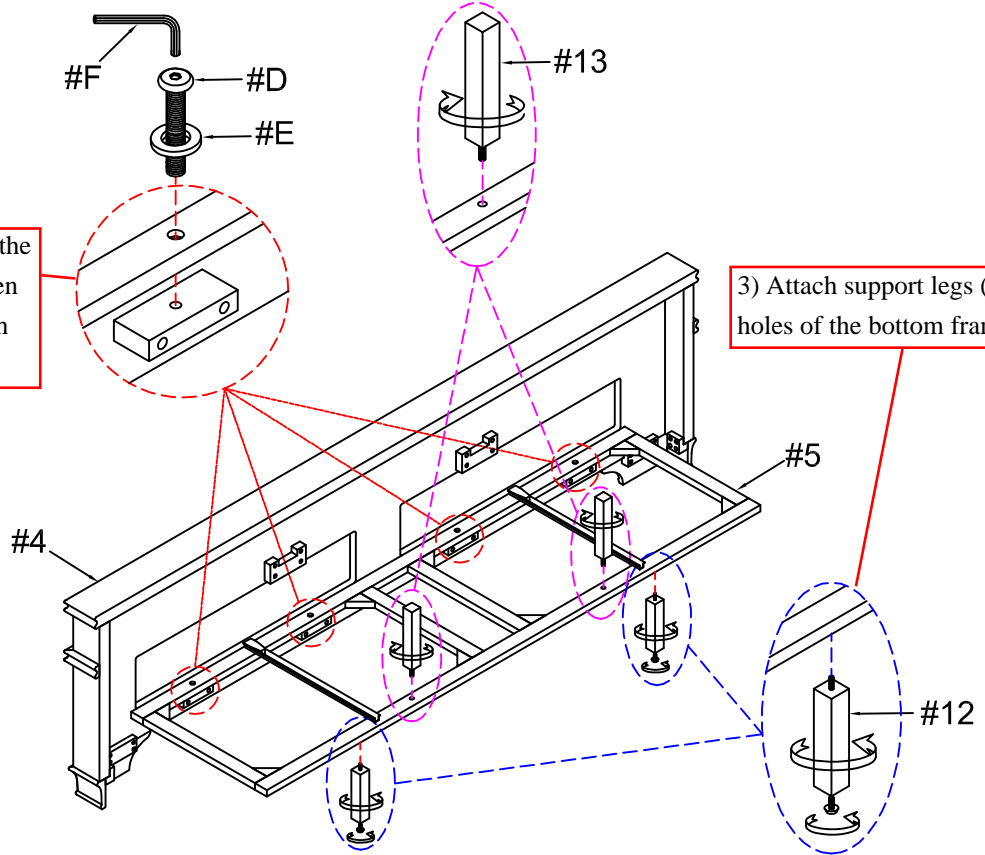

#3

#J x 8pcs
#K x 8pcs
#L x 8pcs

Attach threaded studs (#J) to the holes of the headboard (#1) and footboard (#4), then align side rails (#6R/L) to the threaded studs (#J). Secure by using washer (#K) with hex nut (#L).

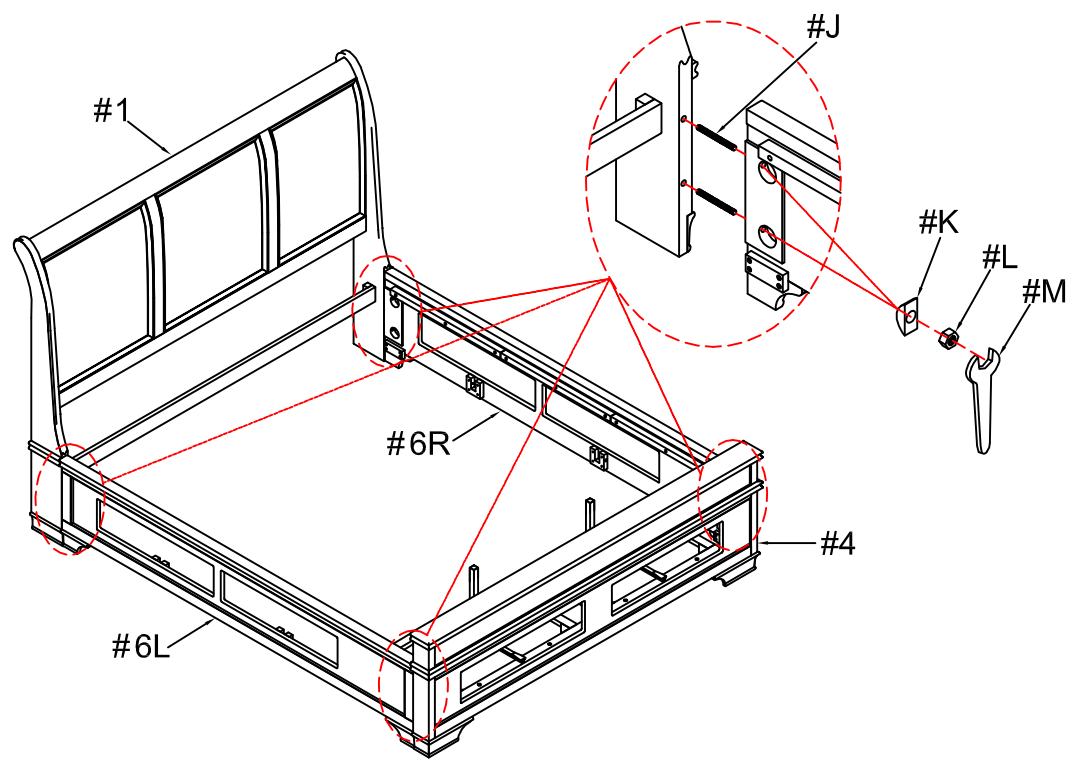



Align rail drawer support slats (#7) to the side rails (#6R/L), then secure by using screws (#H).

#H x 4pcs

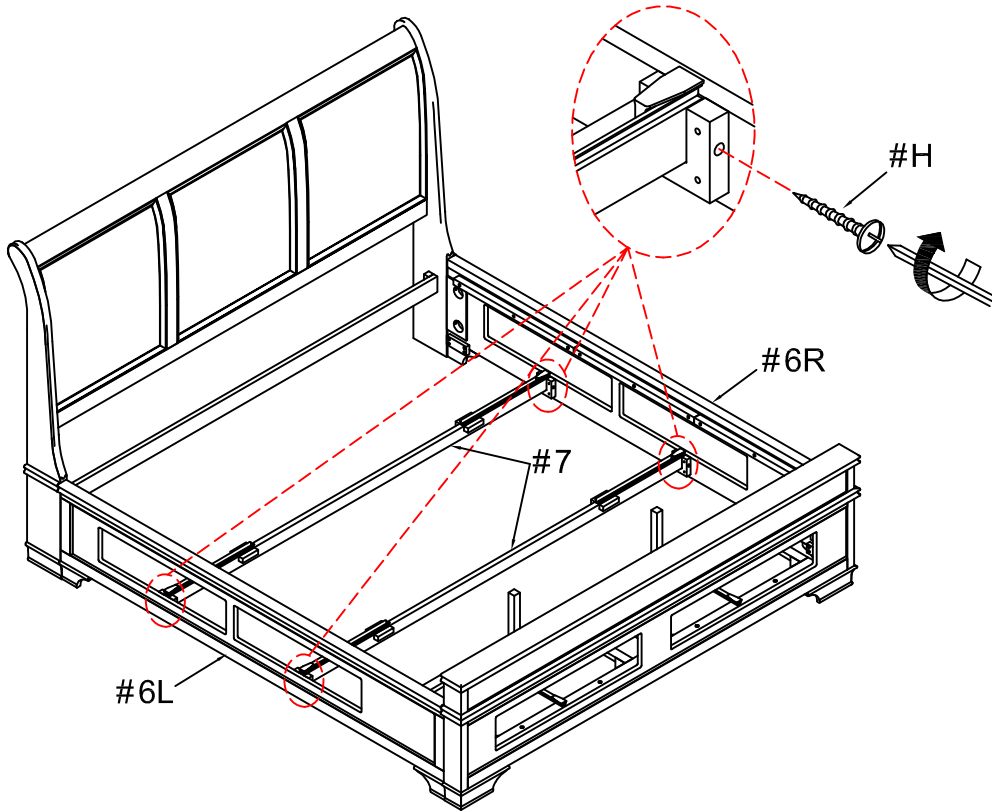

Align and attach support legs (#11) to the holes of the center slats (#8) and bed slats (#14). Adjust the leveler on the support legs (#11) according to ground level.

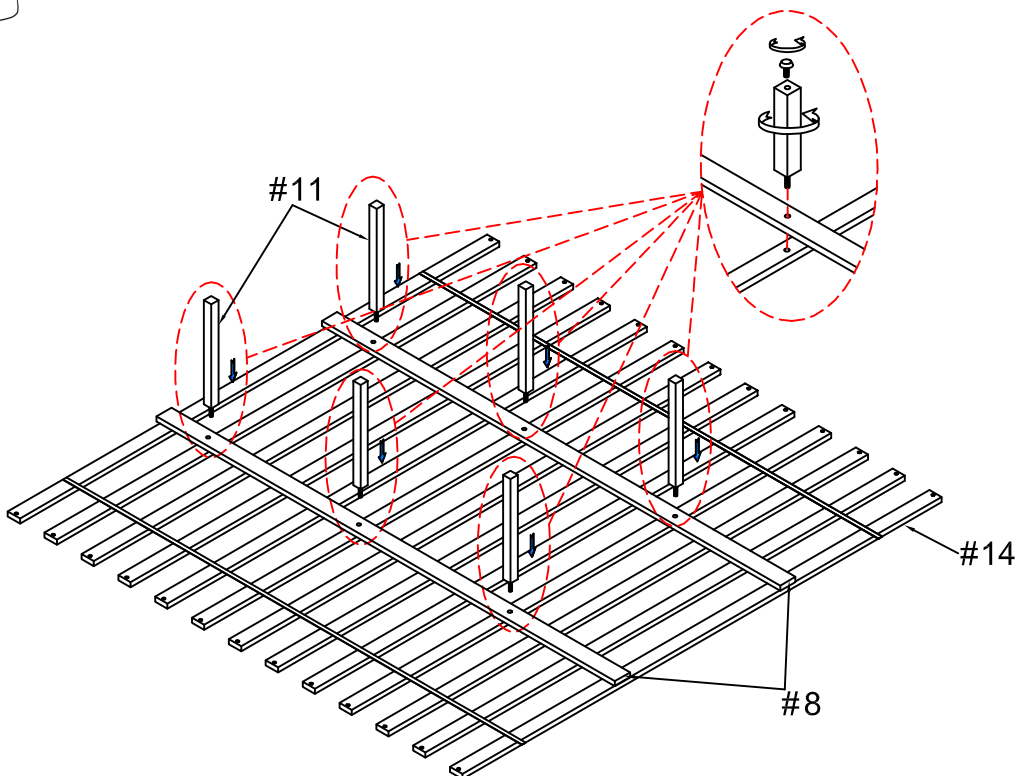



#6

Place bed slats (#14) to the side rails, then secure by using screws (#H).

#H x 26pcs

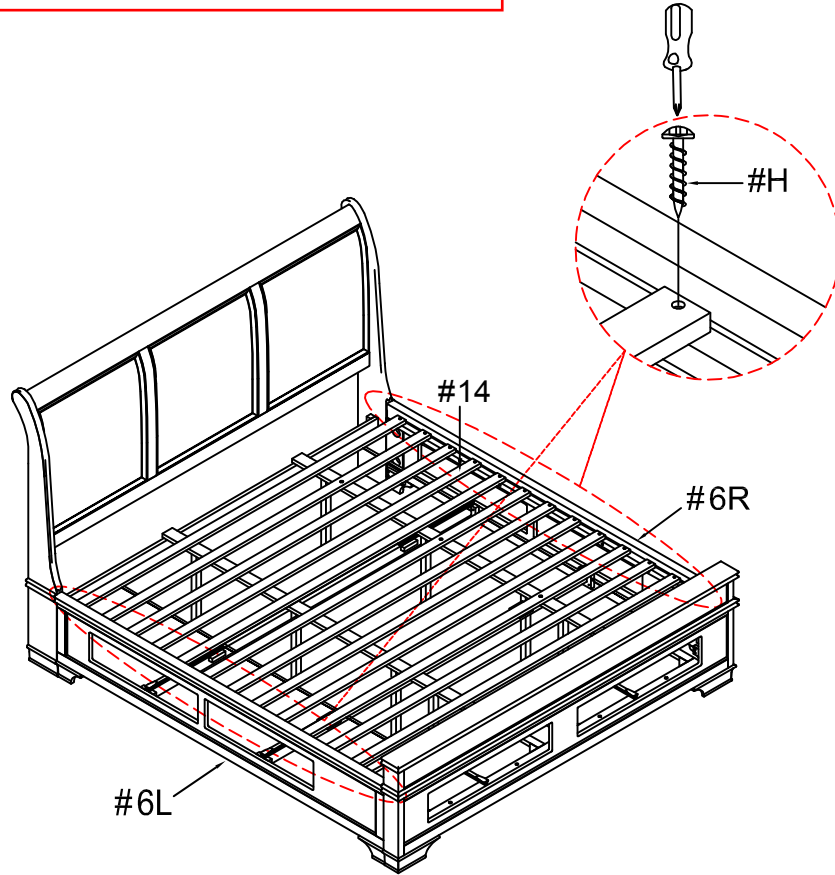

#7

Attach drawers (#9,10) to the drawer slat rails.

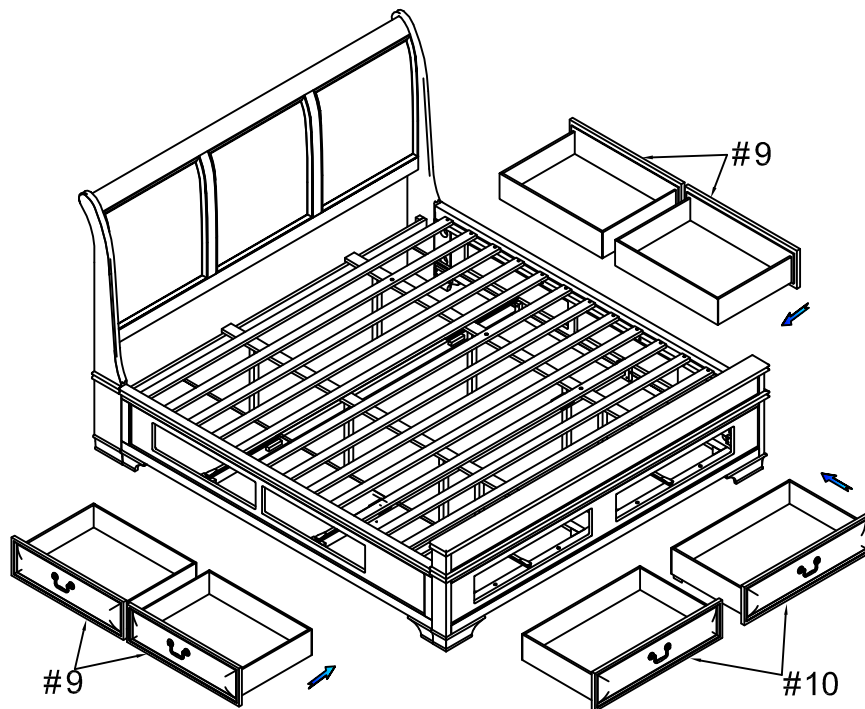



#8

Align top side rails (#15) to the upper holes of the side rails (#6). Secure by using bolts (#D).

#D x 10pcs

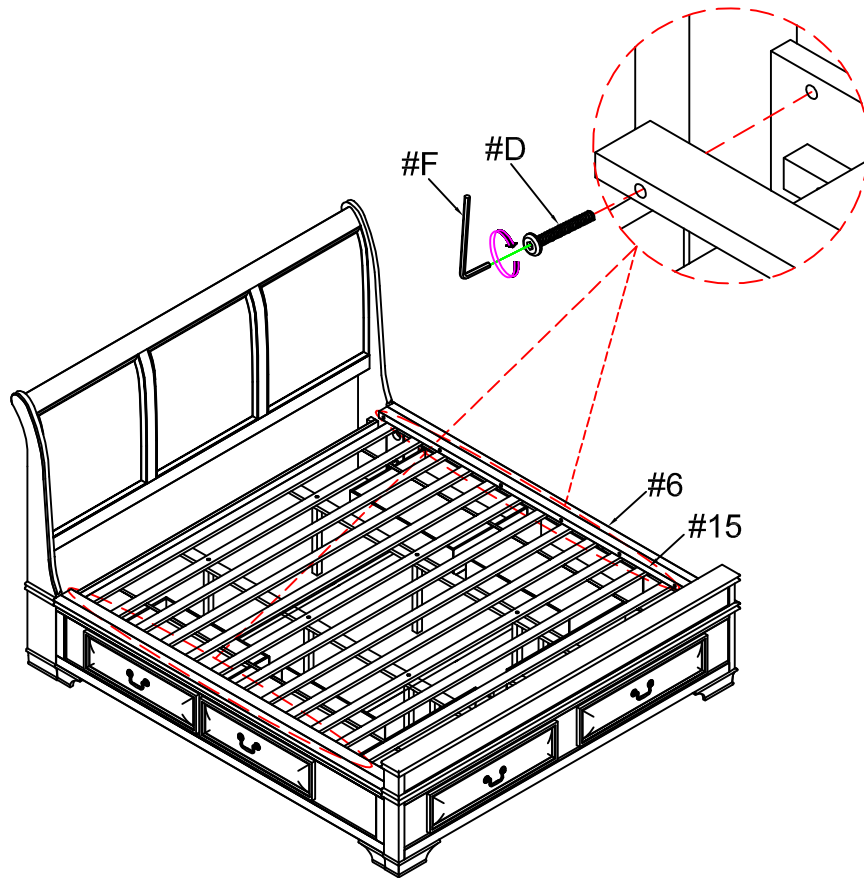

#9

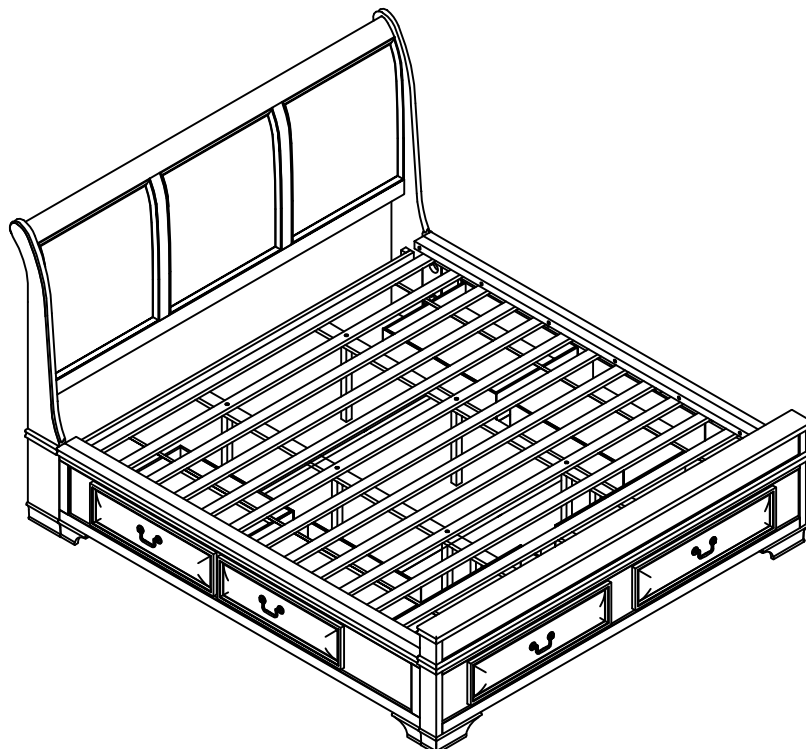

ASSEMBLY IS COMPLETED

Assembly Instructions

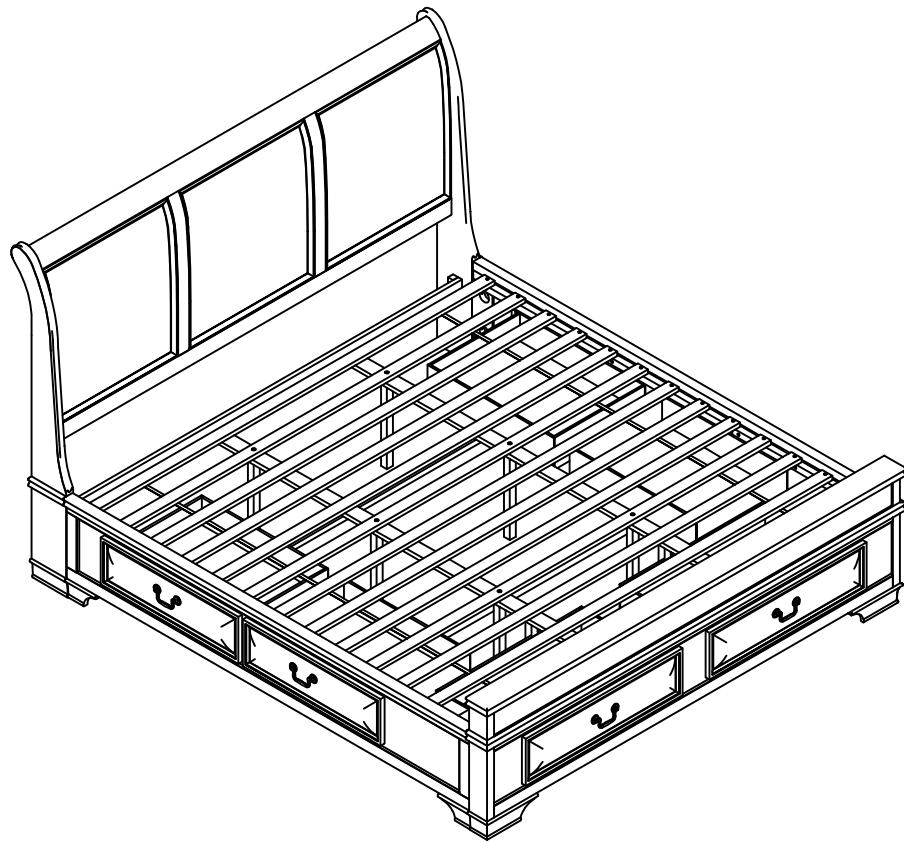

ASSEMBLY RATING

The Assembly Rating is a 5-point system that shows the degree of effort needed in assembling a specific product (with 1 being easy and 5 being difficult). For some products, two persons are recommended.

EASY



DIFFICULT

Tools Required For Assembly:

Allen Wrench

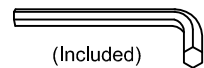

(Included)

Phillips Screwdriver



(Not Included)

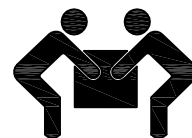

2 PERSONS RECOMMENDED

ASSEMBLY & CARE ADVICE

FOR YOUR FURNITURE TO LAST, CORRECT ASSEMBLY AND PROPER MAINTENANCE ARE NECESSARY. PLEASE FOLLOW THE INFORMATION PROVIDED BELOW TO FULLY ENJOY YOUR FURNITURE.

BASIC ASSEMBLY TECHNIQUES

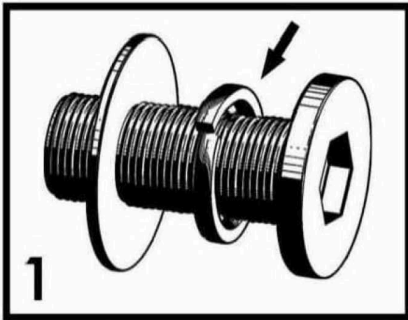

When lock or spring washer is used in an assembly, please make sure the lock or spring washer is placed between the larger flat washer and the head of the screw or bolt.

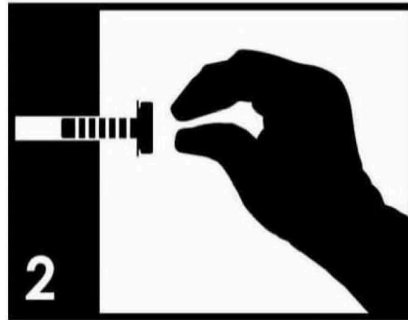

Position each part correctly and insert screws or bolts into their respective holes by hand tighten or using the proper hand tool. Only tighten when step is completed or when instructed to do so.

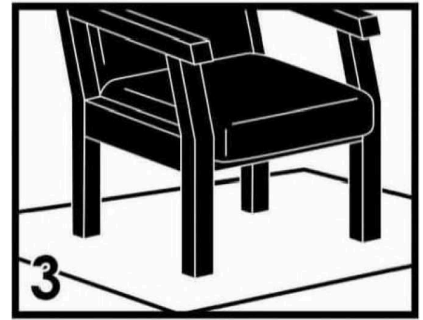

Use cardboard or carpet area when assembling furniture to prevent scratches. Make sure the furniture rests on a flat and level surface with each leg evenly touching the floor.

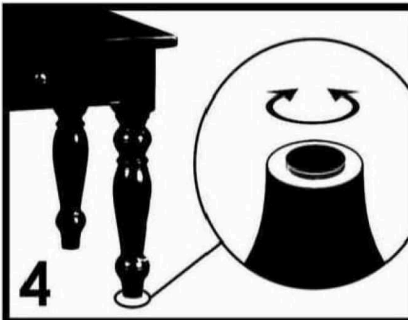

Some furniture comes with height adjustment knobs underneath each leg. To lower or to raise each leg, you need to turn clockwise or counterclockwise, respectively.

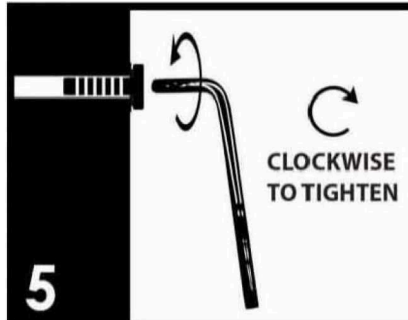

Make sure all parts are properly aligned, then use the appropriate hand tool to completely tighten the bolts or screws. Do not use power tools and do not overtighten.

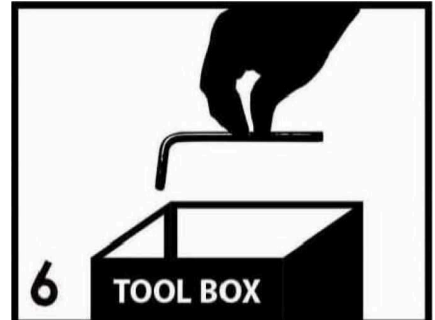

Save the instructions and store the Allen wrench or any supplied tool for later maintenance. After two weeks, check and tighten any loose hardware and repeat again every six months thereafter.

IT IS THE USER'S RESPONSIBILITY TO MAINTAIN THE FURNITURE. THE HARDWARE MAY LOOSEN OVER TIME AND MAY CAUSE THE FURNITURE TO BE WOBBLY AND UNABLE TO SUPPORT ITS INTENDED WEIGHT CAPACITY. THIS MAY LEAD TO COLLAPSE AND MAY CAUSE SERIOUS INJURY.

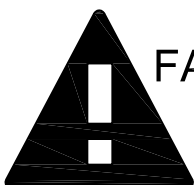



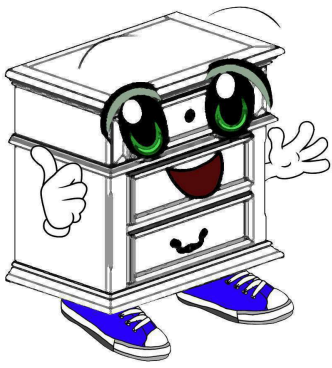



FAILURE TO FOLLOW THE GUIDELINES ABOVE MAY RESULT IN INJURY AND/OR PROPERTY DAMAGE.



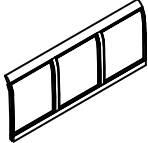

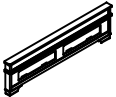



Before you begin, please read Page 2 of "Assembly and Care Advice".

And remember, do not tighten until each step is completed or instructed.

Parts List

-  #1 x 1pc
Headboard Panel
-  #2 x 2pcs
Headboard Leg (L&R)
-  #3 x 1pc
Headboard Support
-  #4 x 1pc
Storage Footboard
-  #5 x 1pc
Bottom Frame for drawer of Footboard
-  #6 x 2pcs
Side Rail (L&R)
-  #7 x 2pcs
Rail Drawer Support Slat
-  #8 x 2pcs
Center Slat

Hardware List

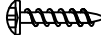
-  #A x 8pcs
Bolt Ø5/16" x 1-3/4"
-  #B x 8pcs
Lock Washer Ø5/16"
-  #C x 8pcs
Flat Washer Ø5/16"
-  #D x 4pcs
Bolt Ø1/4" x 1-1/2"
-  #E x 4pcs
Flat Washer Ø1/4"
-  #F x 1pc
Allen Wrench M4
-  #G x 4pcs
Wooden Dowel 10*40mm
-  #H x 30pcs
Screw #8 x 1-1/4"

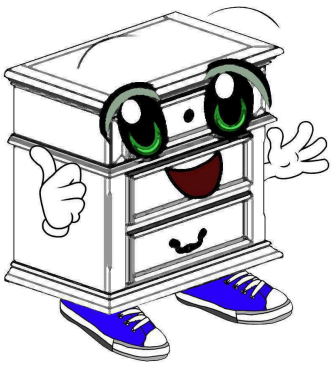

Before you begin, please read Page 2 of "Assembly and Care Advice".

And remember, do not tighten until each step is completed or instructed.

Parts List

Hardware List



#9 x 4pcs
Drawer for Side rail



#J x 8pcs
Threaded Stud Ø5/16"x3-1/2"

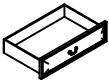

#10 x 2pcs
Drawer for Footboard



#K x 8pcs
Half Moon Ø5/16"

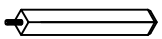

#11 x 6pcs
Long support leg 362x29x29mm



#L x 8pcs
Hex nut Ø5/16"

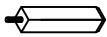

#12 x 2pcs
Short support leg 145x29x29mm

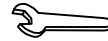

#M x 1pc
Wrench



#13 x 2pcs
Storage Support Leg 195x29x29mm



#14 x 1set
Bed Slat (13pcs)

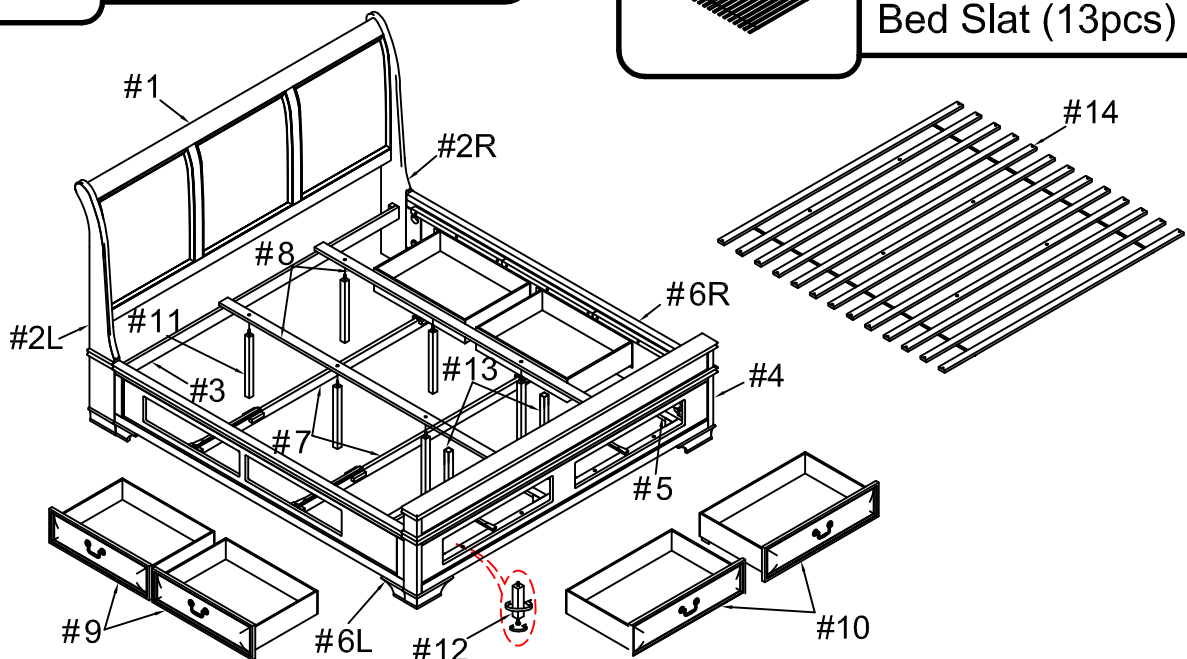



#1

#A x 8pcs
#B x 8pcs
#C x 8pcs
#G x 4pcs

Prepare 8 bolts assembly by inserting lock washer (#B), then flat washer (#C) onto bolts (#A). Attach dowels (#G) to the holes of the HB legs (#2R/L), then align HB legs (#2R/L) to the HB panel (#1) and HB support (#3). Secure by using bolts (#A).

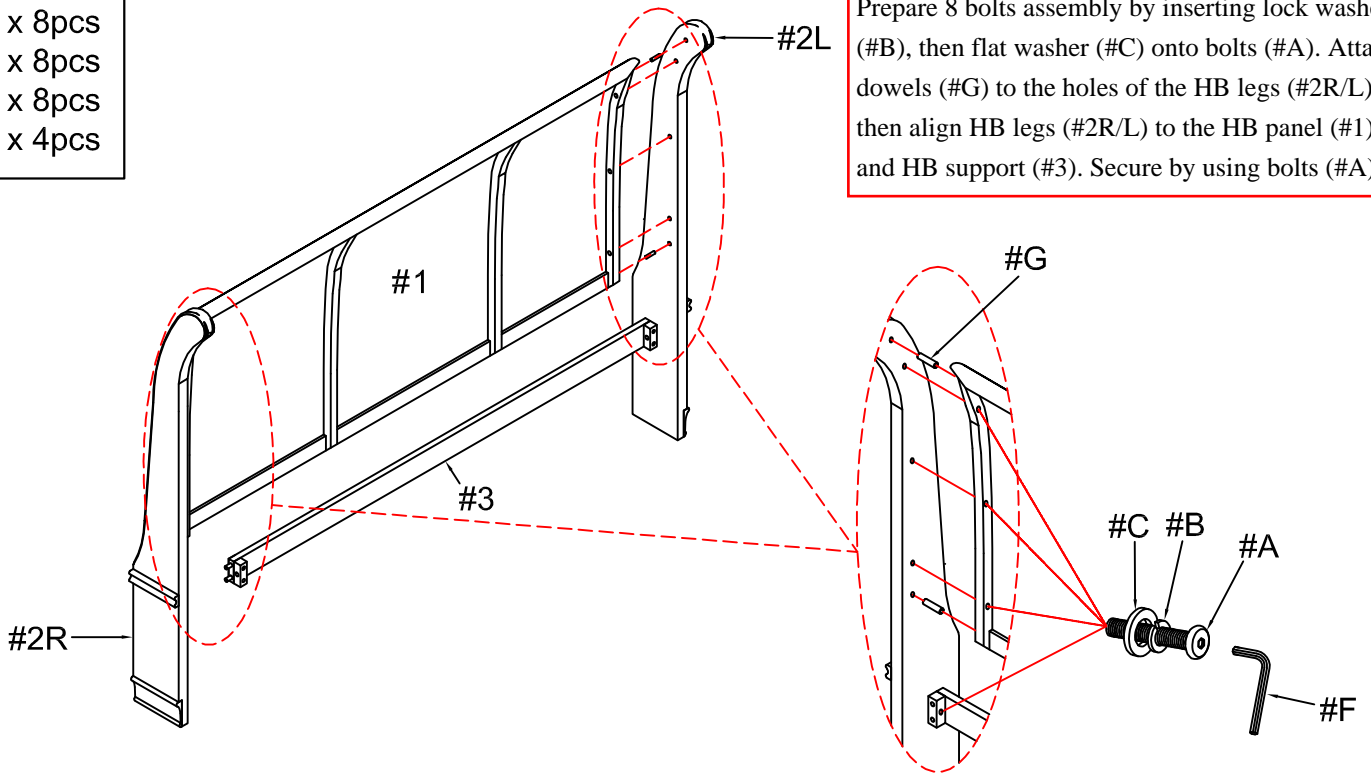

#2

#D x 4pcs
#E x 4pcs

1) Align bottom frame (#5) to the holes of the footboard (#4), then secure by using bolts (#D) with washers (#E).

2) Attach support legs (#13) to the holes of the bottom frame (#5).

3) Attach support legs (#12) to the holes of the bottom frame (#5).

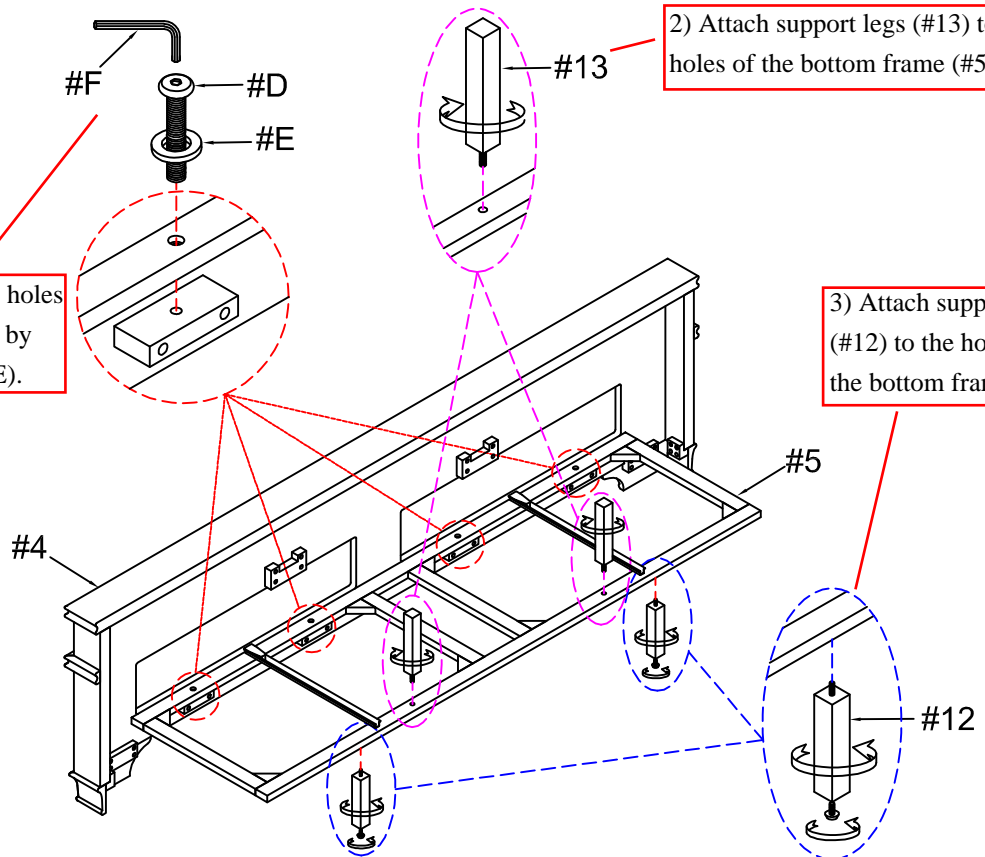



#3

Attach threaded studs (#J) to the holes of the headboard (#1) and footboard (#4), then align side rails (#6R/L) to the threaded studs (#J). Secure by using washer (#K) with hex nut (#L).

#J x 8pcs
#K x 8pcs
#L x 8pcs

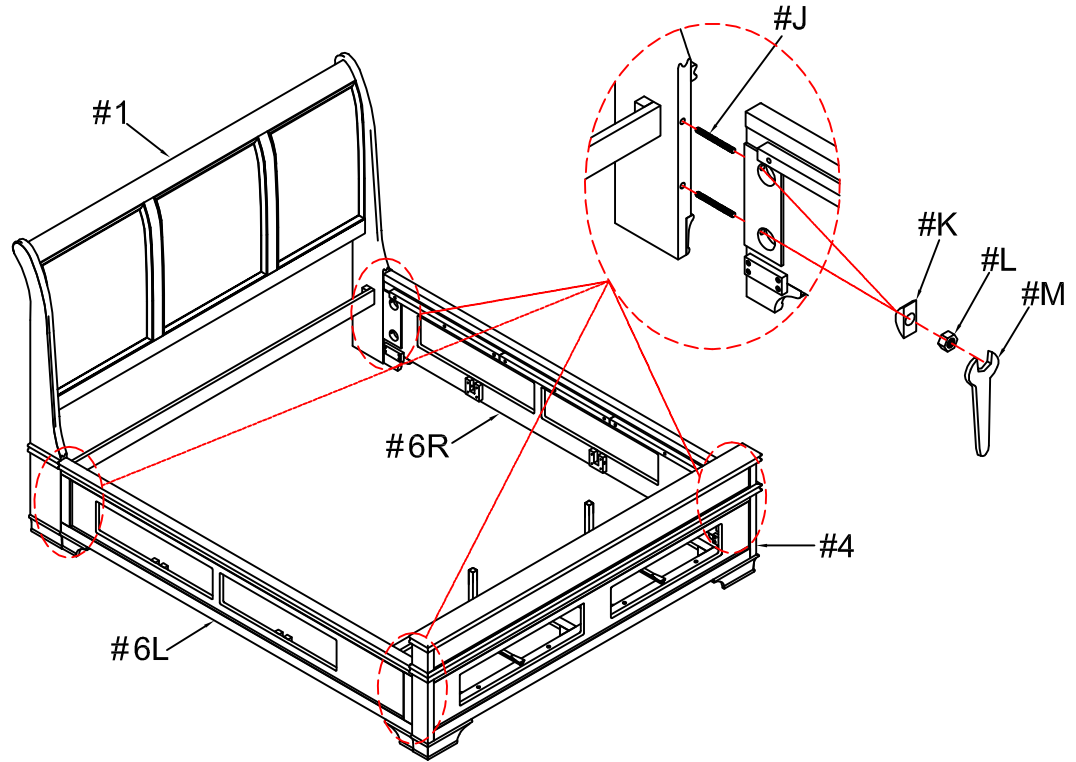

#4

Align rail drawer support slats (#7) to the side rails (#6R/L), then secure by using screws (#H).

#H x 4pcs

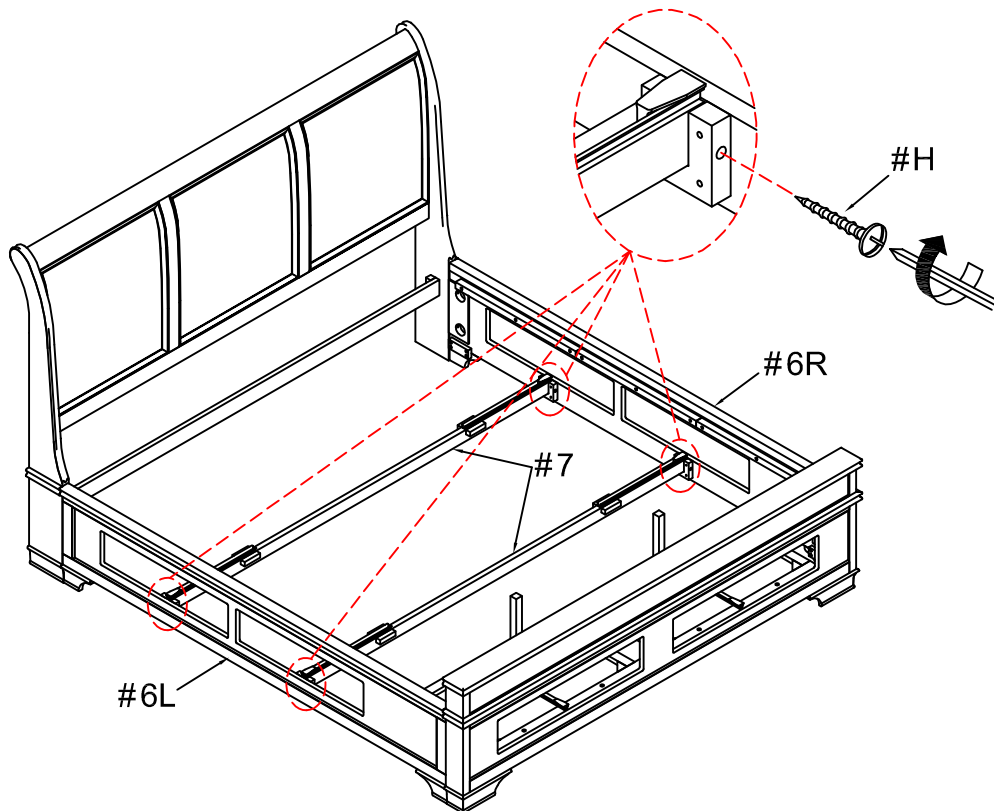



Align and attach support legs (#11) to the holes of the center slats (#8) and bed slats (#14).
Adjust the leveler on the support legs (#11) according to ground level.

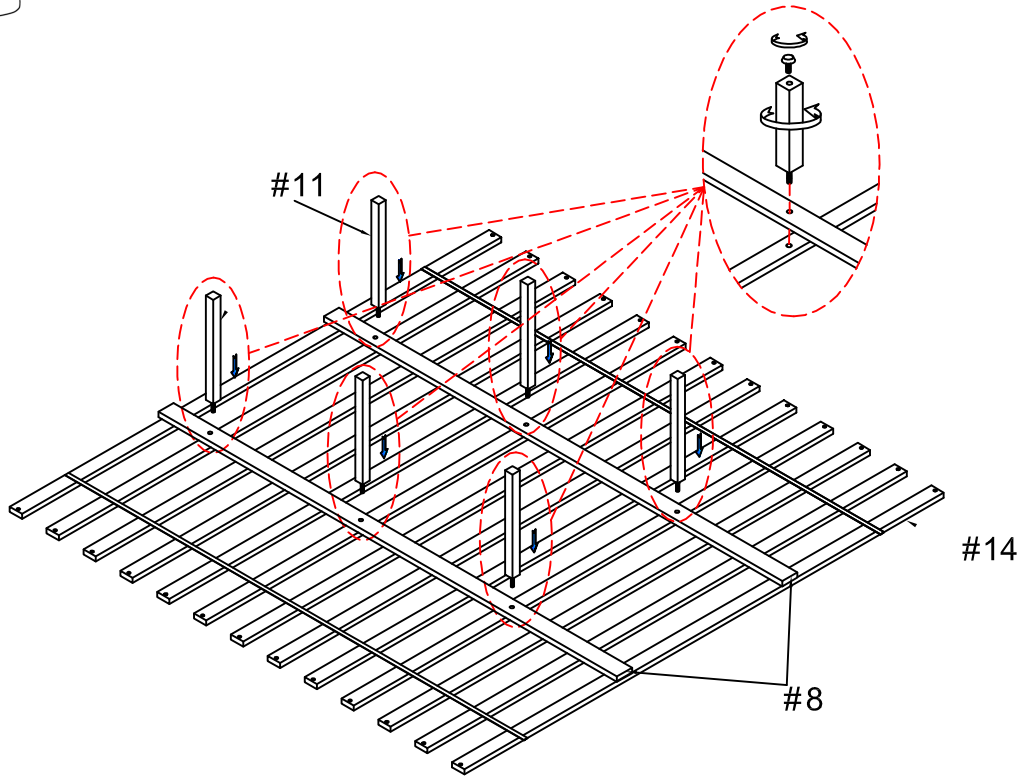

Place bed slats (#14) to the side rails, then secure by using screws (#H).

#H x 26pcs

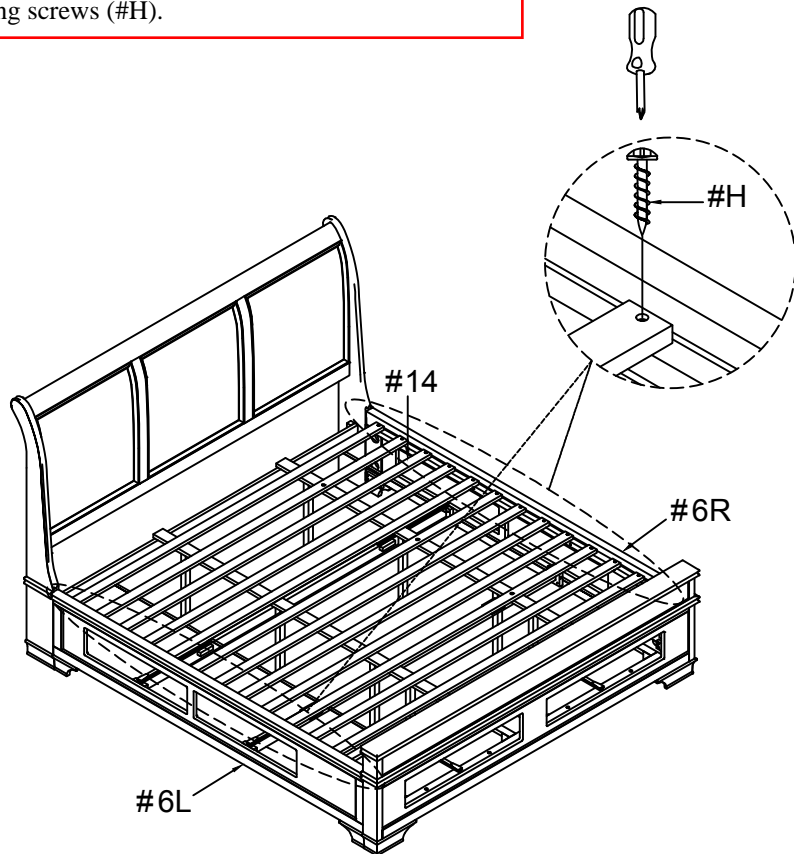



Attach drawers (#9,10) to the drawer slat rails.

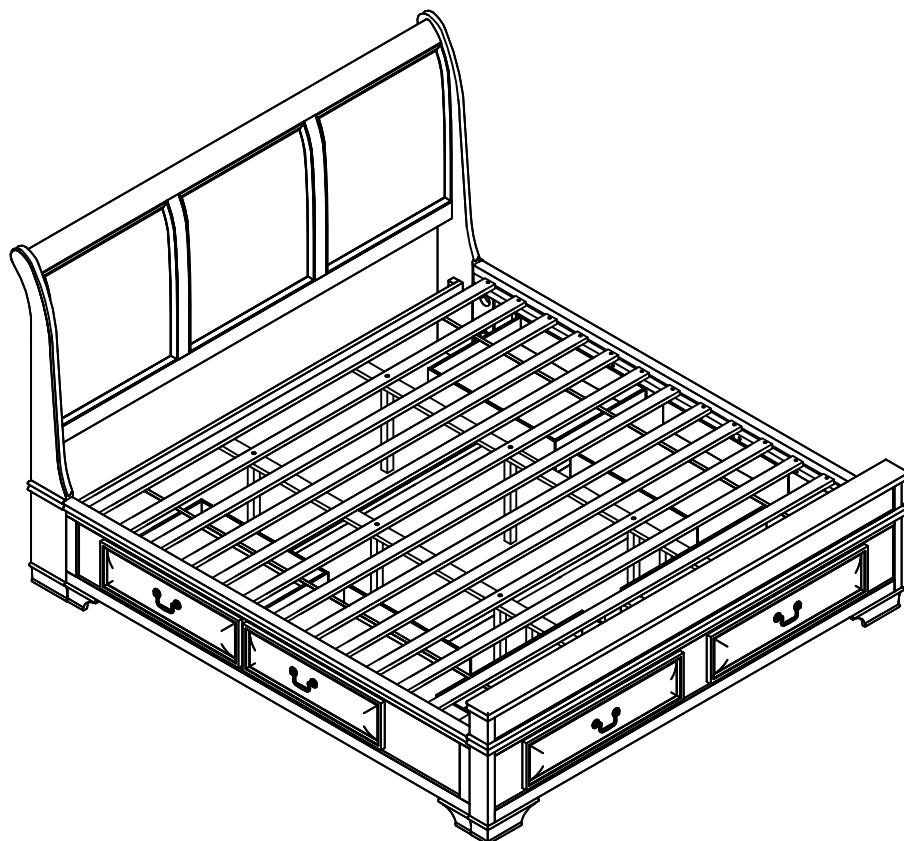
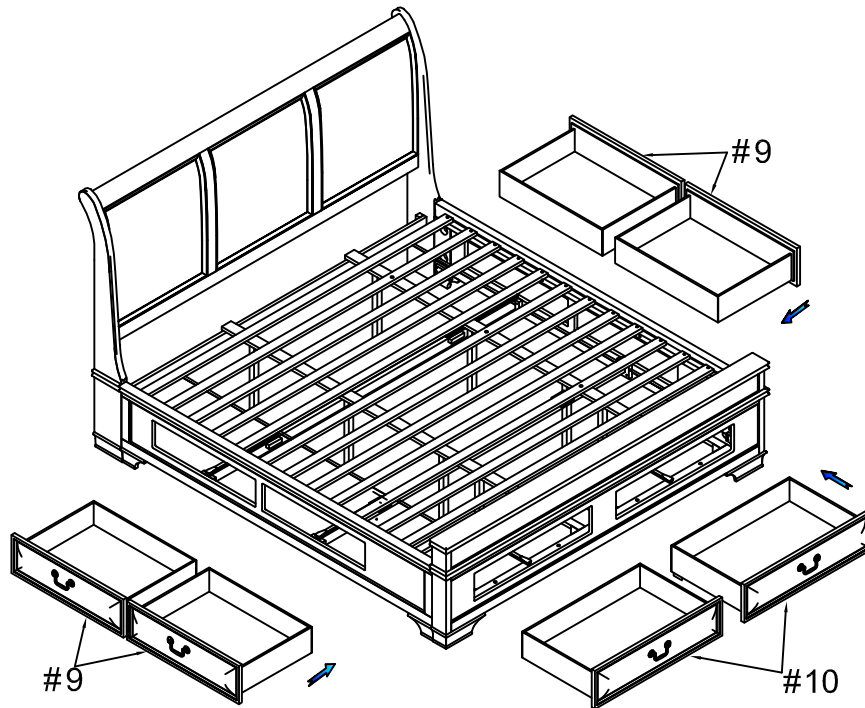

ASSEMBLY IS COMPLETED