

ASSEMBLY INSTRUCTIONS

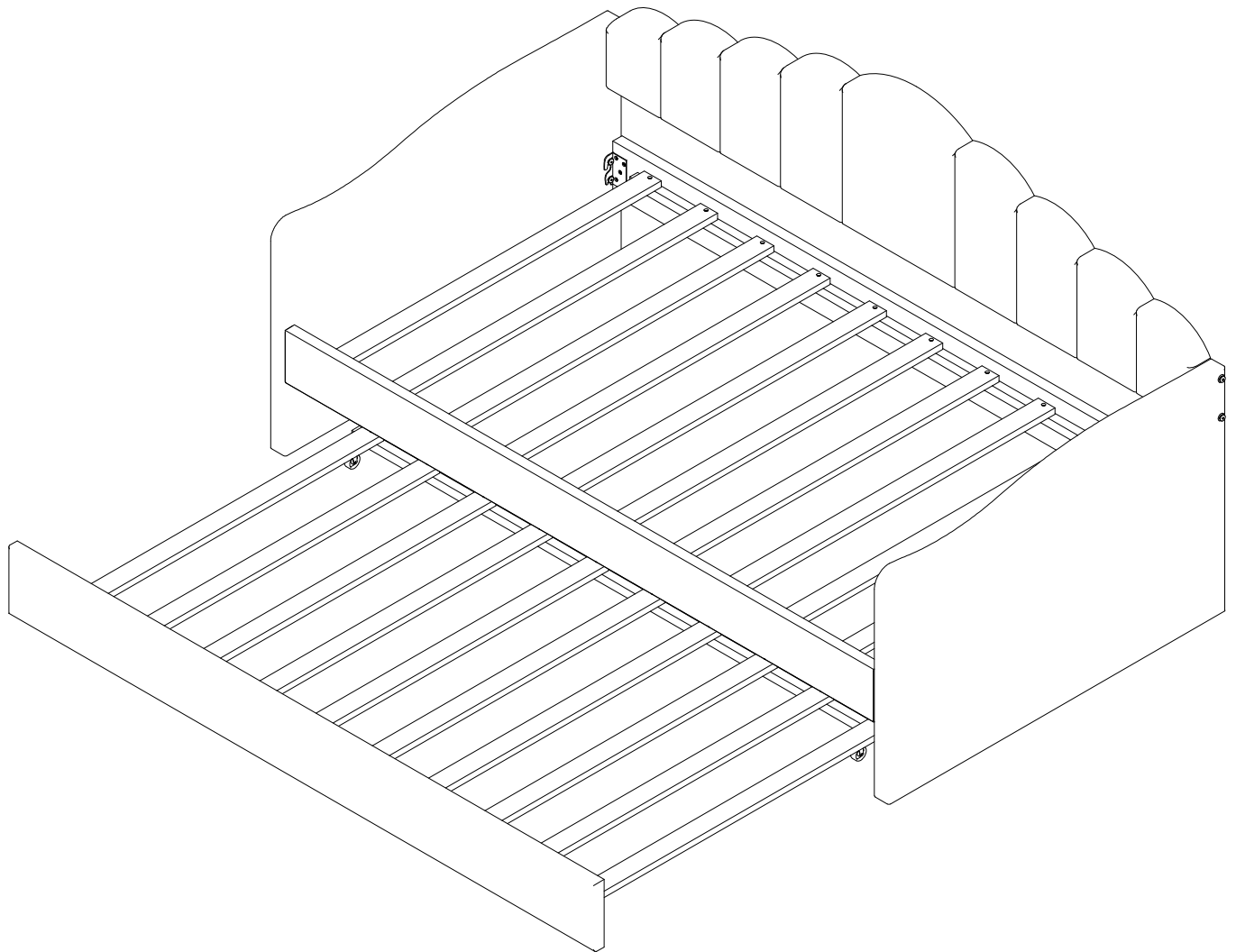

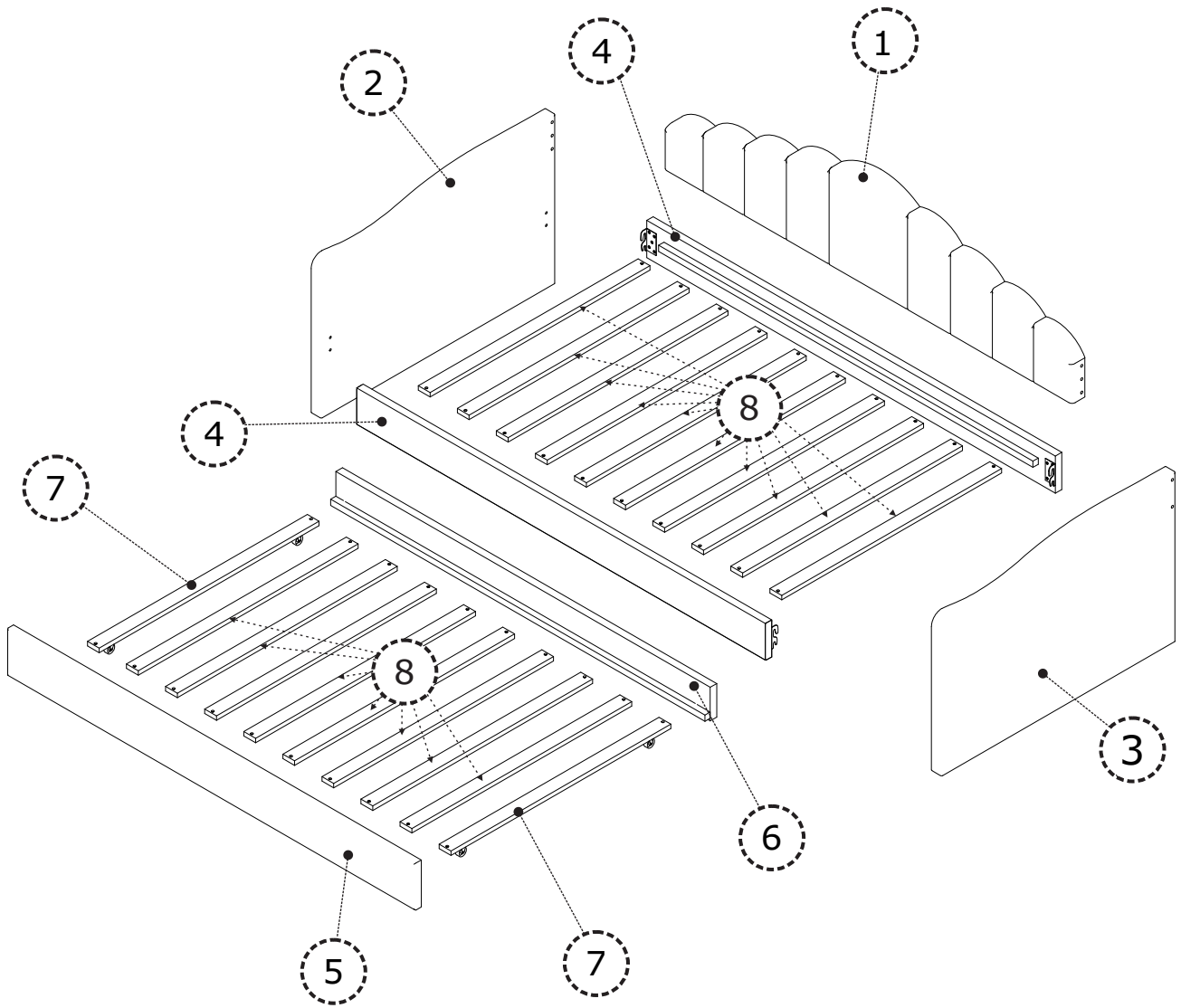

PARTS

Check that you've received
all parts listed below.

BOX: 1/2

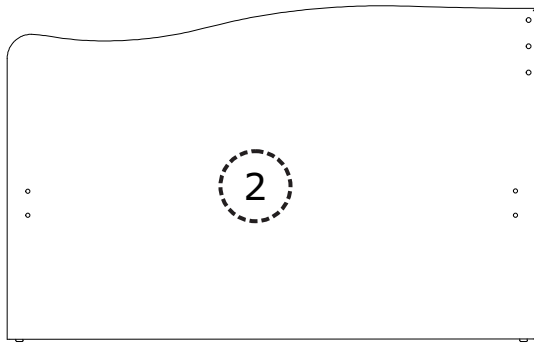

(1 pc)

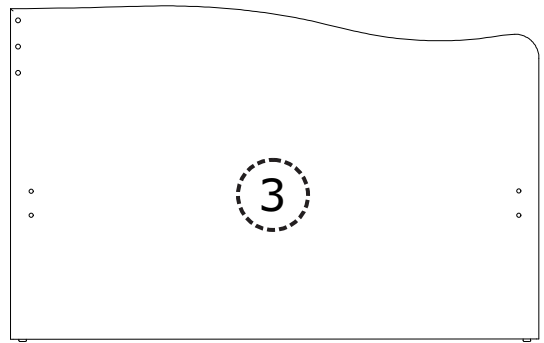

(1 pc)



(18 pcs)



(2 pcs)

BOX: 2/2



(1 pc)



(2 pcs)



(1 pc)



(1 pc)

Hardware



HARDWARE

Check that you've received
all hardware listed below.

A



Ø 5/16" x 38 mm

8 pcs

B

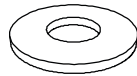

Ø 19 x 1.5 mm

12 pcs

C



Ø 13 x 1 mm

12 pcs

D



80 x 23 x 4 mm

1 pc

E

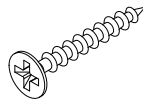

Ø 4 x 15 mm

16 pcs

F

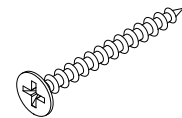

Ø 4 x 30 mm

40 pcs

G

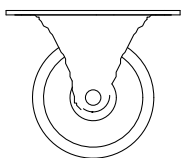

50 x 45 x 25 mm

4 pcs

H

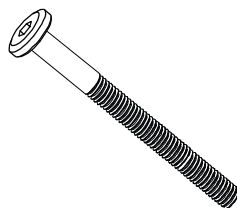

Ø 5/16" x 110 mm

4 pcs



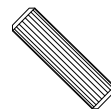

I



Ø 8 x 20 mm



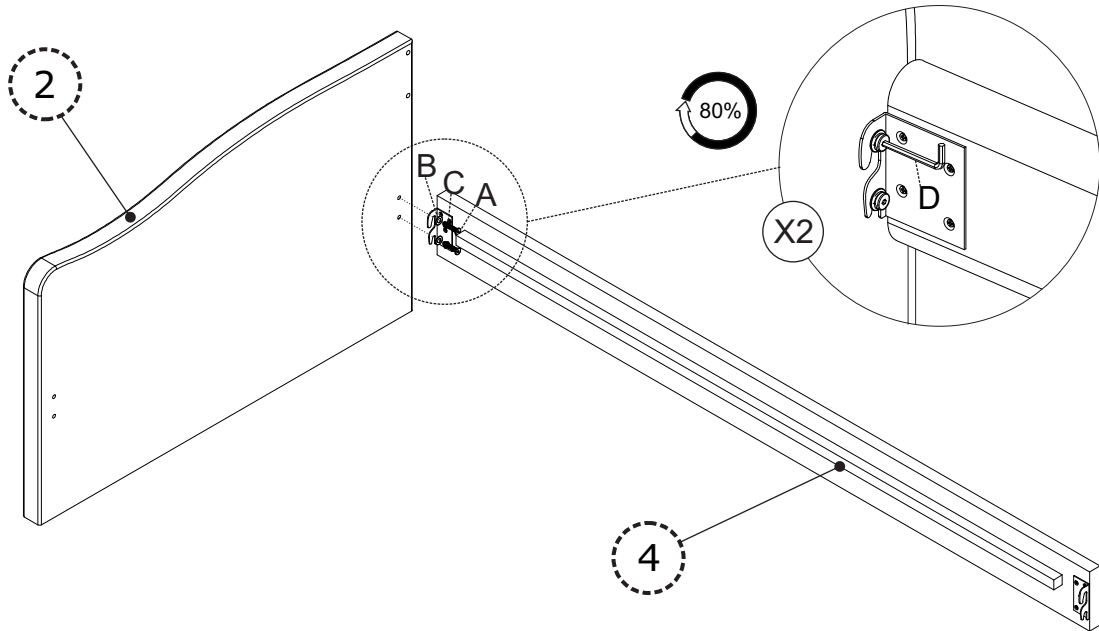

2 pcs

STEP 1

A x 2  Ø 5/16" x 38 mm	B x 2  Ø 19 x 1.5 mm	C x 2  Ø 13 x 1 mm	D x 1  80 x 23 x 4 mm	
---	---	---	--	--





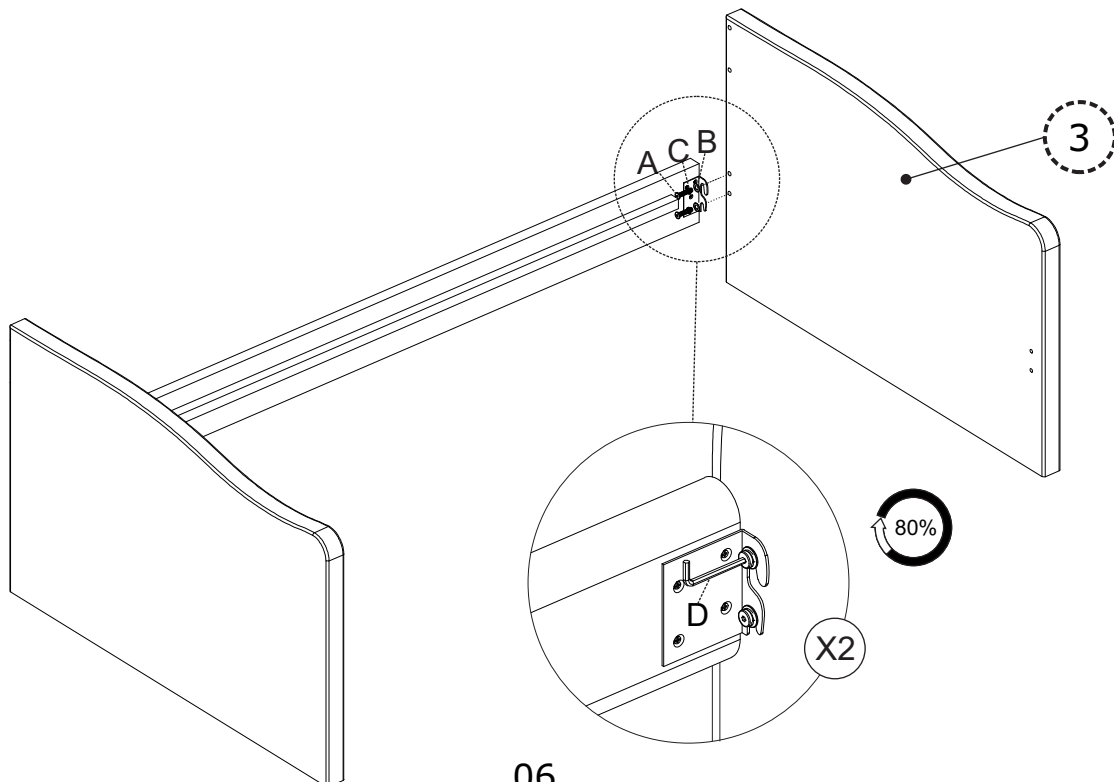

STEP 2

A x 2  Ø 5/16" x 38 mm	B x 2  Ø 19 x 1.5 mm	C x 2  Ø 13 x 1 mm	D x 1  80 x 23 x 4 mm	
---	---	---	--	--





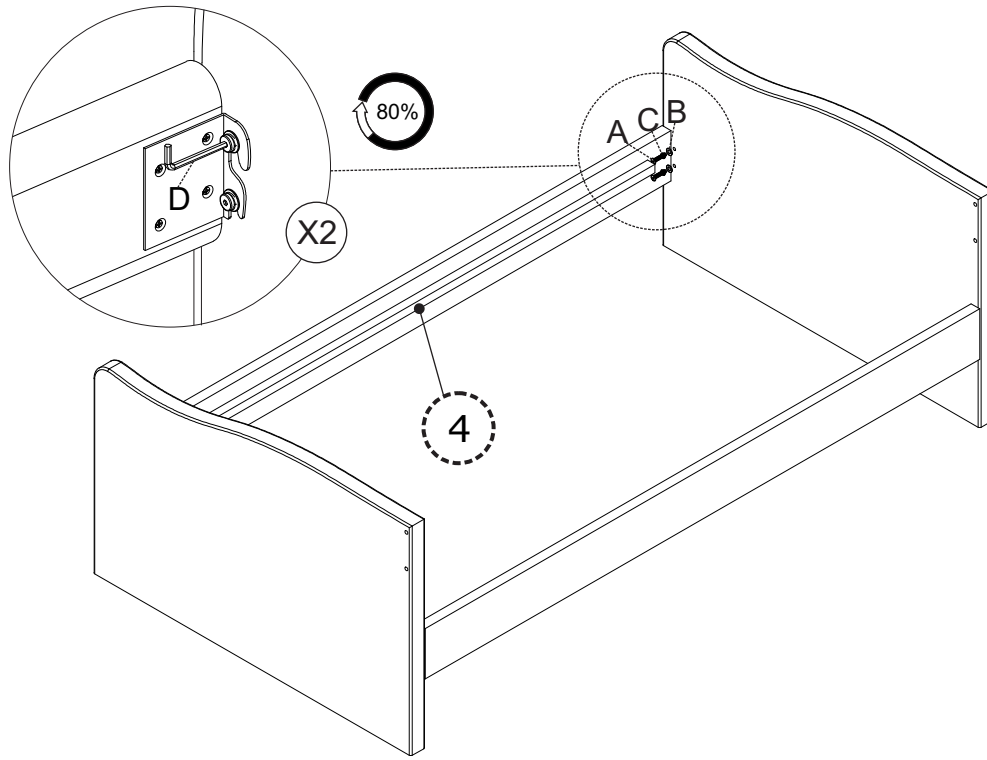

STEP 3

A x 2  Ø 5/16" x 38 mm	B x 2  Ø 19 x 1.5 mm	C x 2  Ø 13 x 1 mm	D x 1  80 x 23 x 4 mm	
---	---	---	--	--



STEP 4



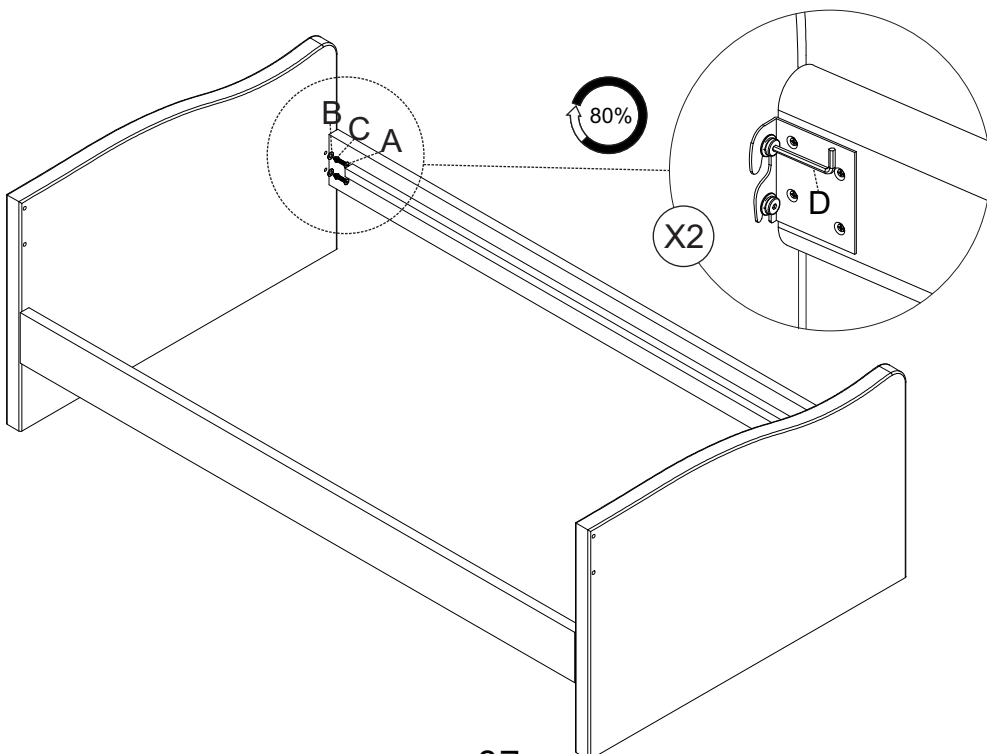

A x 2  Ø 5/16" x 38 mm	B x 2  Ø 19 x 1.5 mm	C x 2  Ø 13 x 1 mm	D x 1  80 x 23 x 4 mm	
---	---	---	--	--

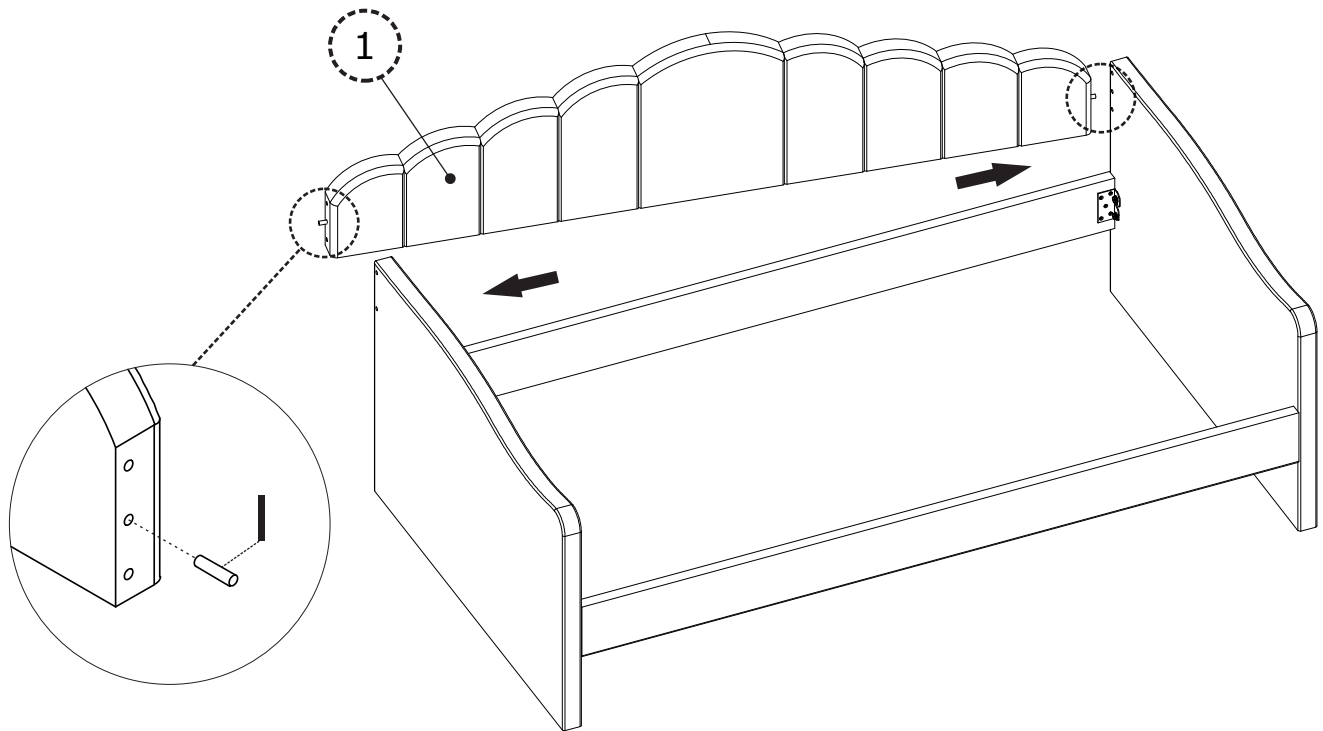
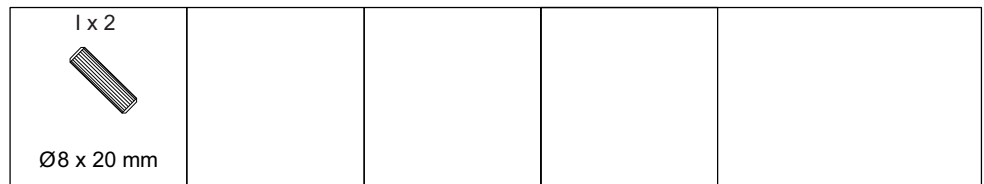

STEP 5





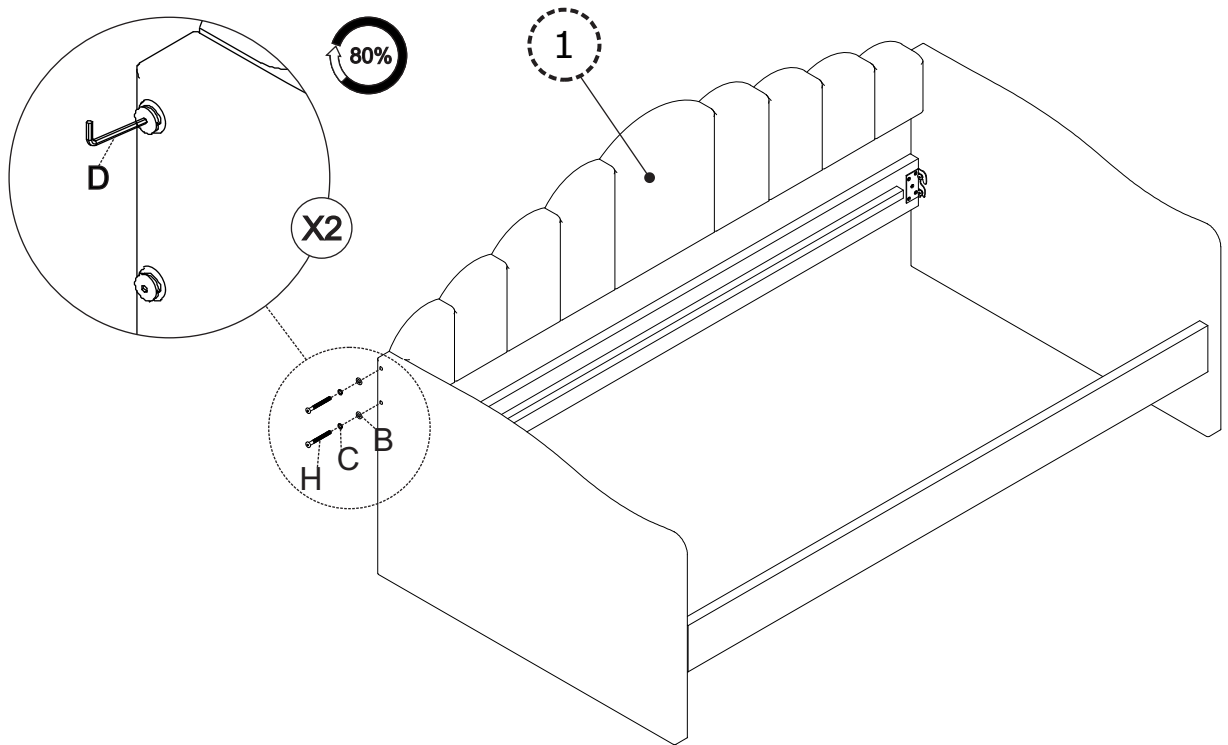

STEP 6

H x 2  Ø 5/16" x 110 mm	B x 2  Ø 19 x 1.5 mm	C x 2  Ø 13 x 1 mm	D x 1  80 x 23 x 4 mm	
--	---	---	--	--



STEP 7

H x 2  Ø 5/16" x 110 mm	B x 2  Ø 19 x 1.5 mm	C x 2  Ø 13 x 1 mm	D x 1  80 x 23 x 4 mm	
--	---	---	--	--

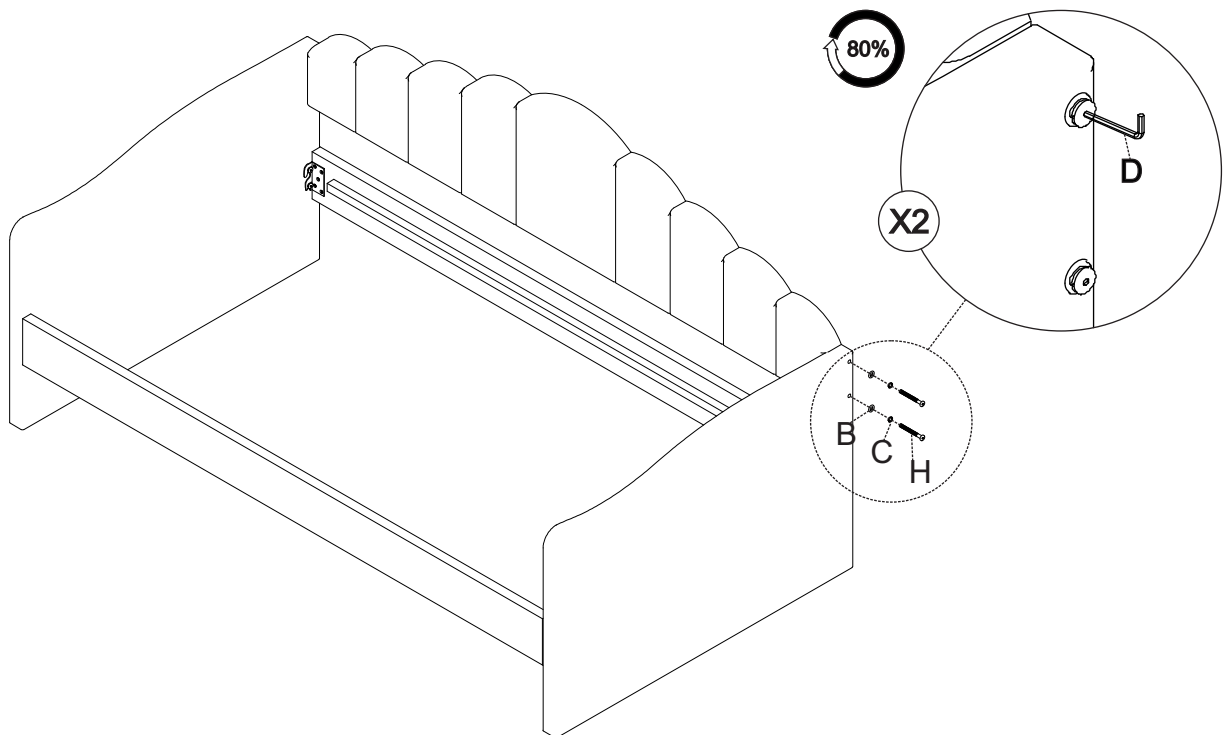

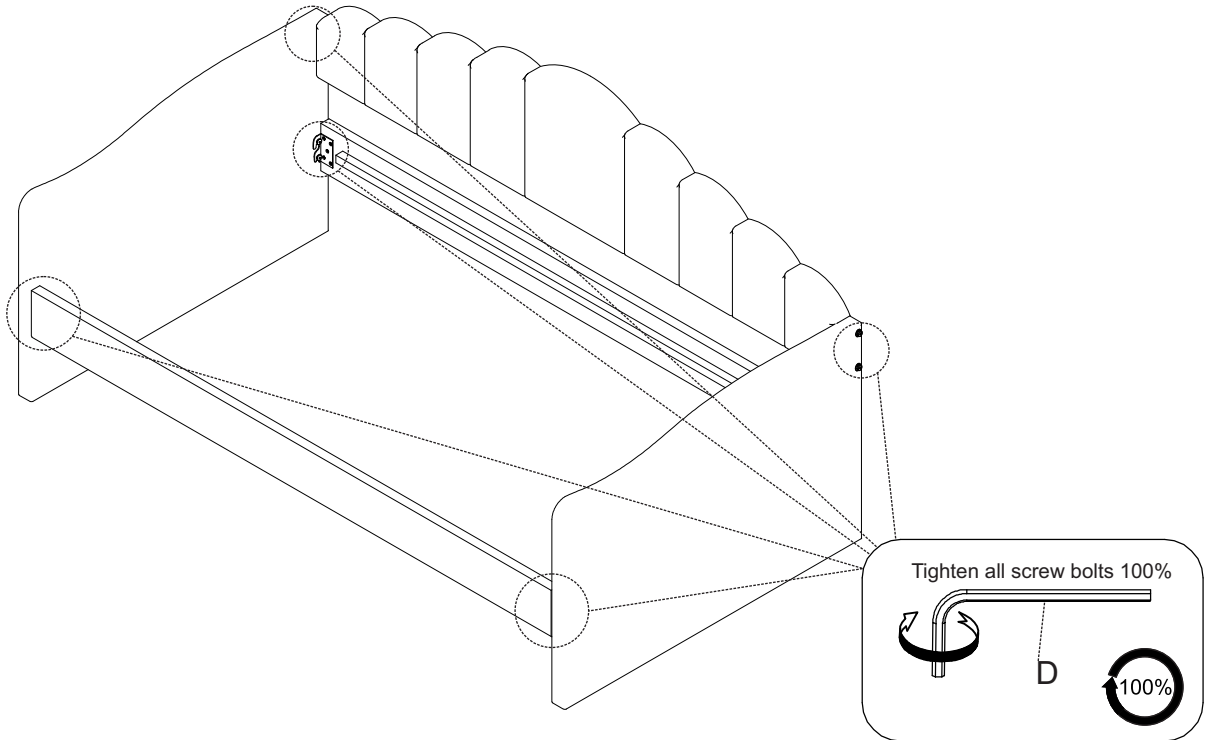
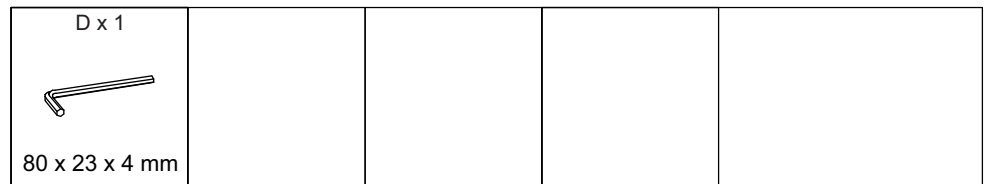

STEP 8

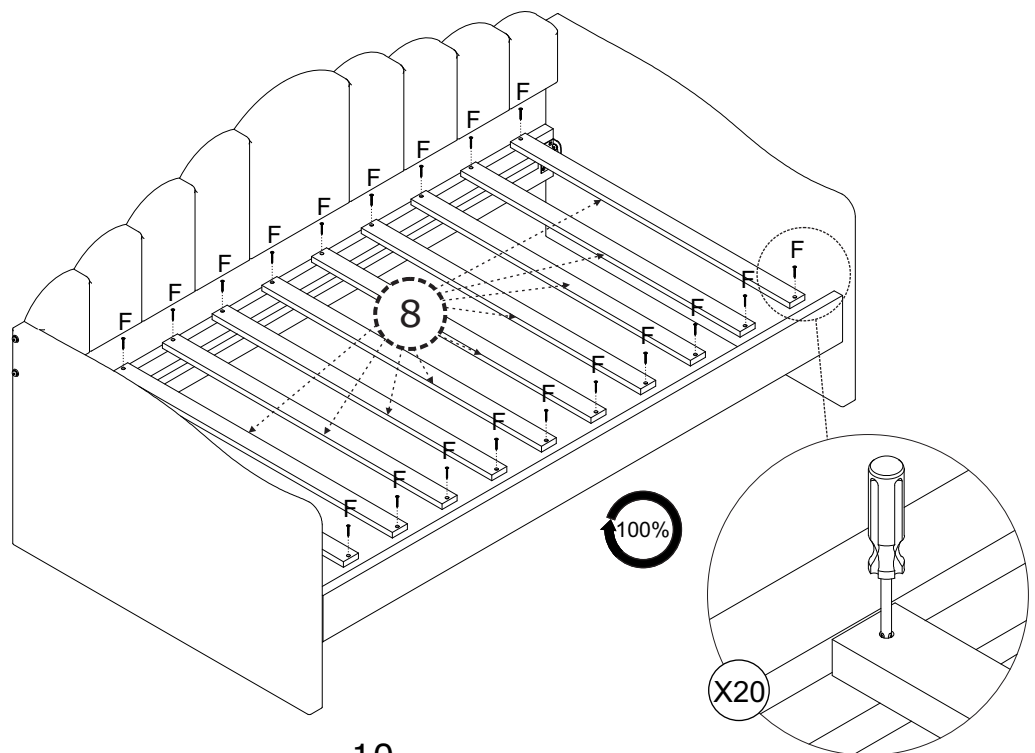
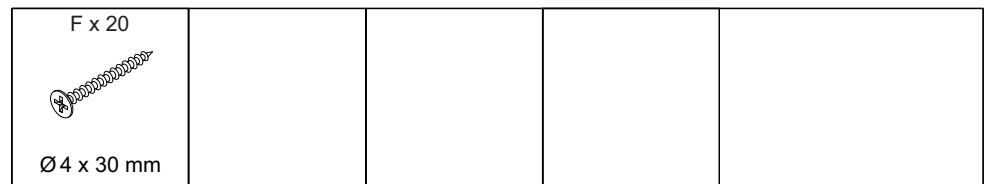

STEP 9



STEP 10

E x 16  Ø4 x 15 mm	G x 4 			
---	--	--	--	--

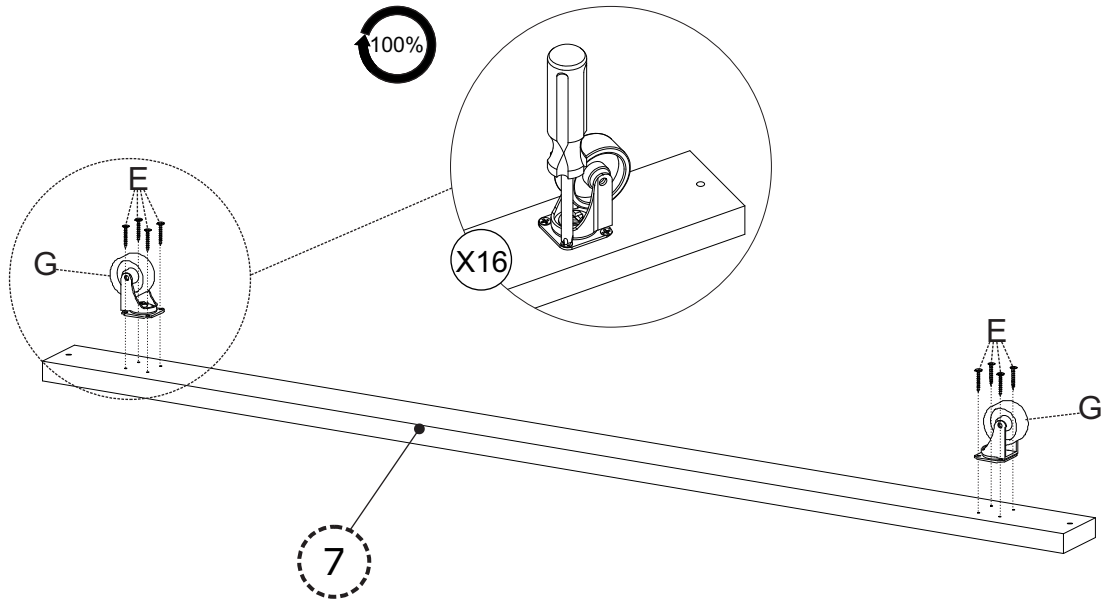

STEP 11

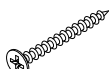
F x 4  Ø4 x 30 mm				
--	--	--	--	--

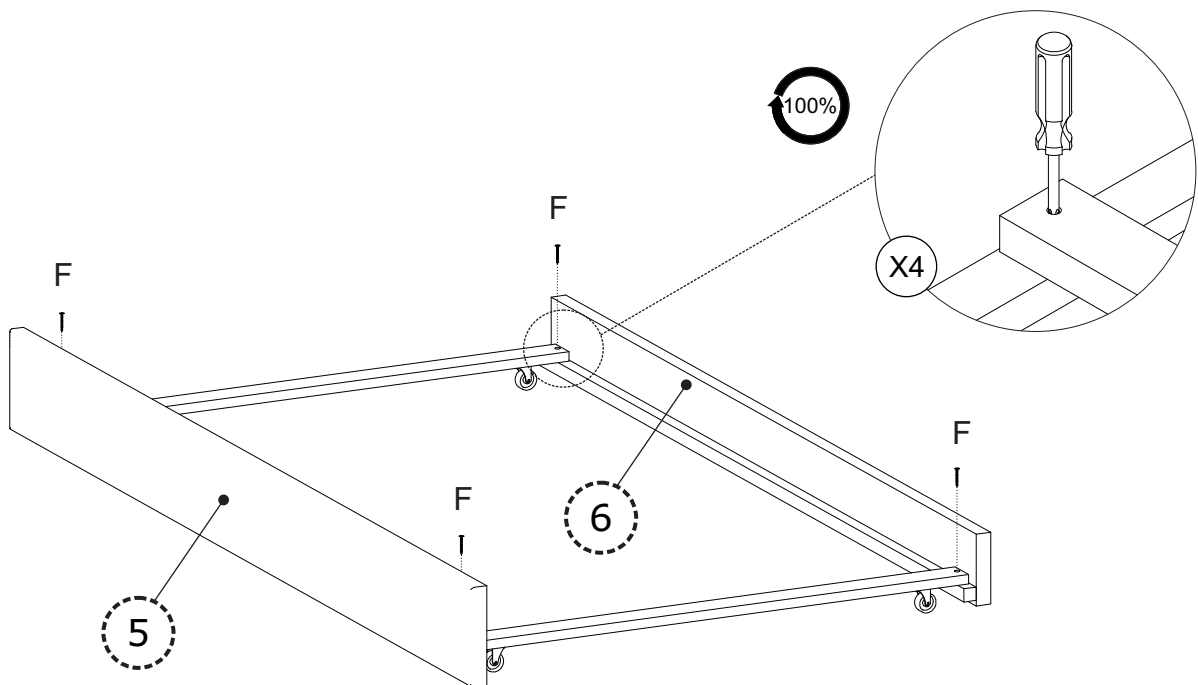

STEP 12

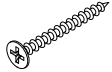
F x 20  Ø4 x 30 mm				
---	--	--	--	--

