











# Assembly Instructions

**Caution : You must read this before you proceed**

## Care & Maintenance

- ⊘  ● Not for commercial use. For residential use only.
- ✓  ● Furniture may scratch floors. We recommend using furniture pads to protect your floors.
- ⊘  ● Do not put hot items directly on furniture surface.
- ⊘  ● Do not clean furniture with harsh cleansers or polish.
- ⊘  ● Do not place furniture under direct sunlight.
- ⊘  ● Do not place furniture near heating or cooling vents.
- ⊘  ● Do not write on furniture without a padded barrier to protect the surface.
- ⊘  ● Do not place furniture outside . For indoor use only.
- ⊘  ● Stains may be removed with mild soap solution and damp cloth.
- ⊘  ● Children should not climb or jump on the furniture.







- Dust and pick-up spills using a clean, non-colored, lint-free cloth.

Please look in small carton for hardware packs and legs.  
Sets often ship in multiple boxes and may arrive a day or two apart.



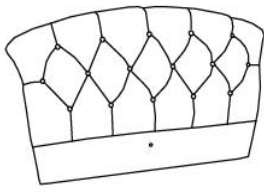

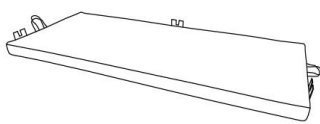
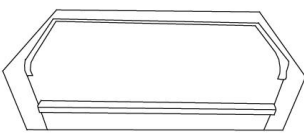
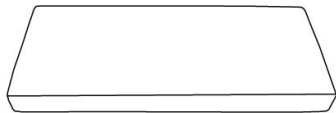
# LOVESEAT CHAISE LOUNGE













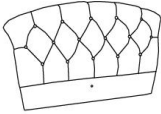

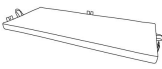
## Parts List

Label	Picture	Description	QTY
A		Backrest	1
B		Left Armrest	1
C		Right Armrest	1
D		Seat Board	1
E		Seat	1
F		Seat Cushion	1
G		Pillow	2
H		Leg	6
Carton"A"	D*1, E*1,F*1, H*6,Hardware*1		
Carton"B"	A*1, B*1, C*1, G*2		

# Hardwares

Label	Picture	Description	QTY
①		Bolt (M8*60 MM)	7
②		Washer(M8*22)	7
③		Spring Washer(M8)	7
④		Allen Wrench	1
⑤		Gasket	9

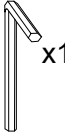
## Assembly Preparation

Before Begining Assembly:	Ax1	Bx1	Cx1	Dx1	Ex1	Fx1	
							
	Gx2	Hx6	①	②	③	④	⑤
			 x7	 x7	 x7	 x1	 x9



- Read instructions, cover to cover



- Have 2 adults on hand for assembly



- Do not assemble on flooring or carpet



- Assemble on a clean non-marring surface (packing foam)



- Save all packaging until finished

# Assembly Steps

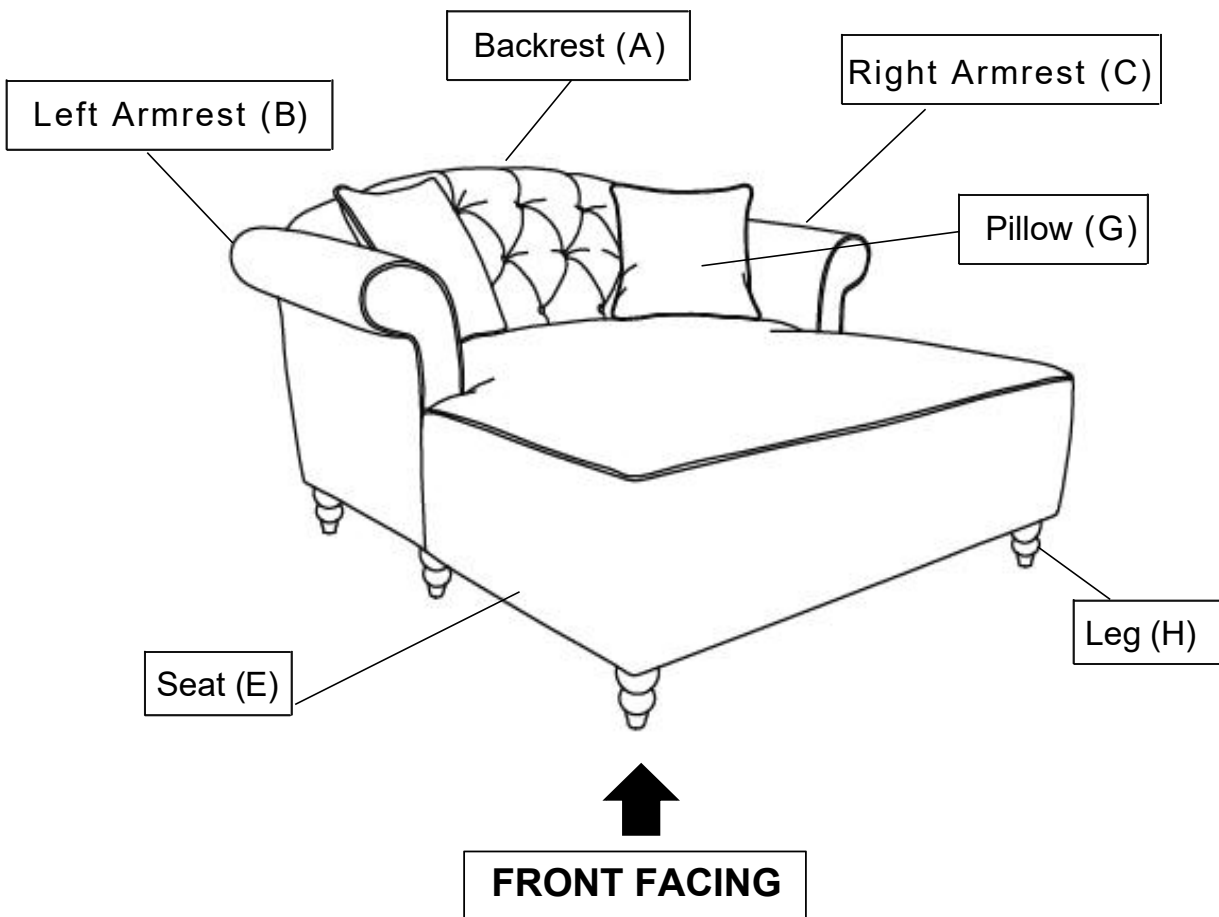

This Loveseat Chaise Lounge has multiple parts and may require up to 30 minutes to assemble. To give you an overview of the Loveseat Chaise Lounge parts, the above picture is to help you put the various parts into perspective.

Please read through the instructions below to familiarise yourself with the parts and steps before assembly.

Note: It is recommended that you have an adult partner to assist during the entire assembly process.

## Step 1

Carton "A"

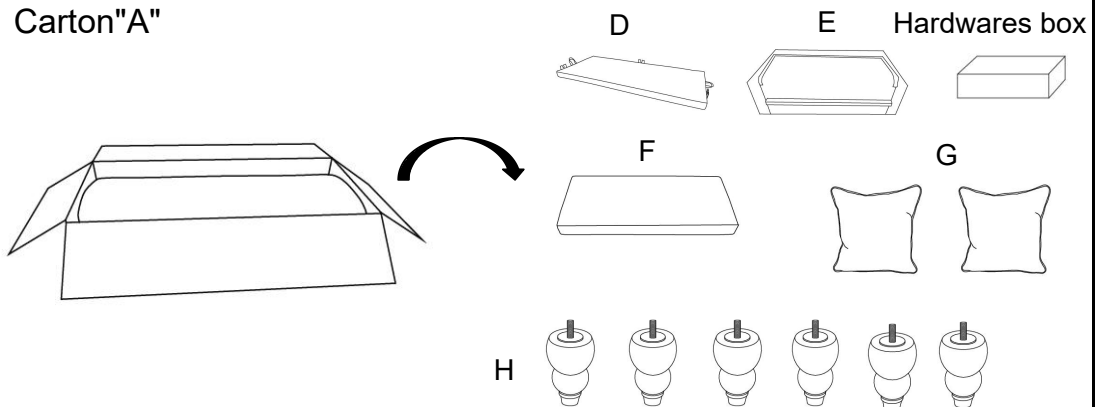

Take out the Seat Board(D), Seat(E), Seat Cushion(F), Pillows(G), Legs(H) and Hardware box from the Carton "A", place it on a clean, non-marring surface.

## Step 2

Carton "B"

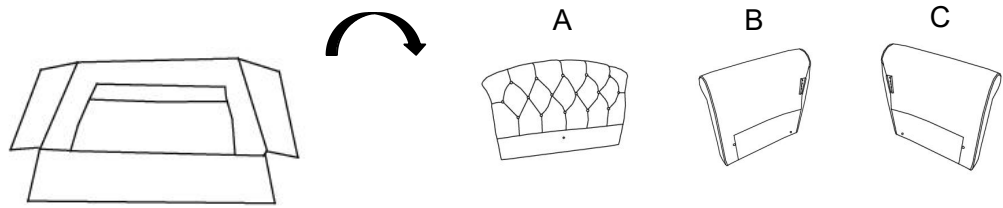

Take out the Backrest(A), Left Armrest(B), Right Armrest(C) from the carton "B" and place them on a clean, non-marring surface.

## Step 3

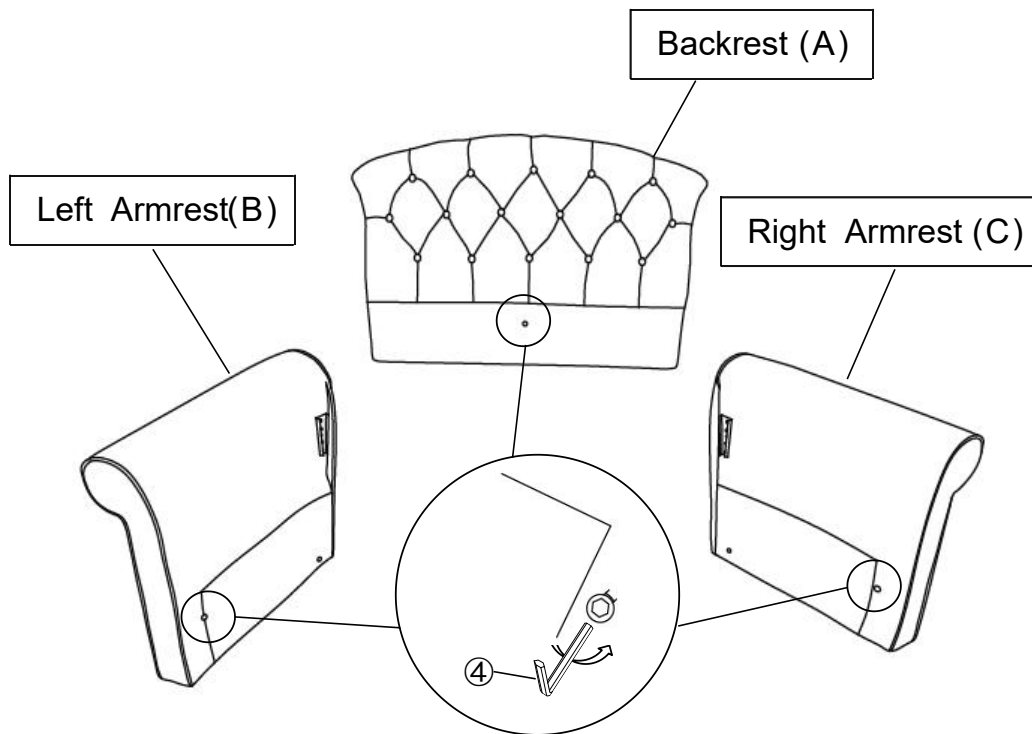

Unscrew the Bolts on the left Armrest(B), Right Armrest(C) and the Backrest(A) with the Allen Wrench(④) as shown partly.

**Note: Do not take the bolts off, just make a gap between bolts' head and base about 5~10mm for inserting bracket sheet.**

## Step 4

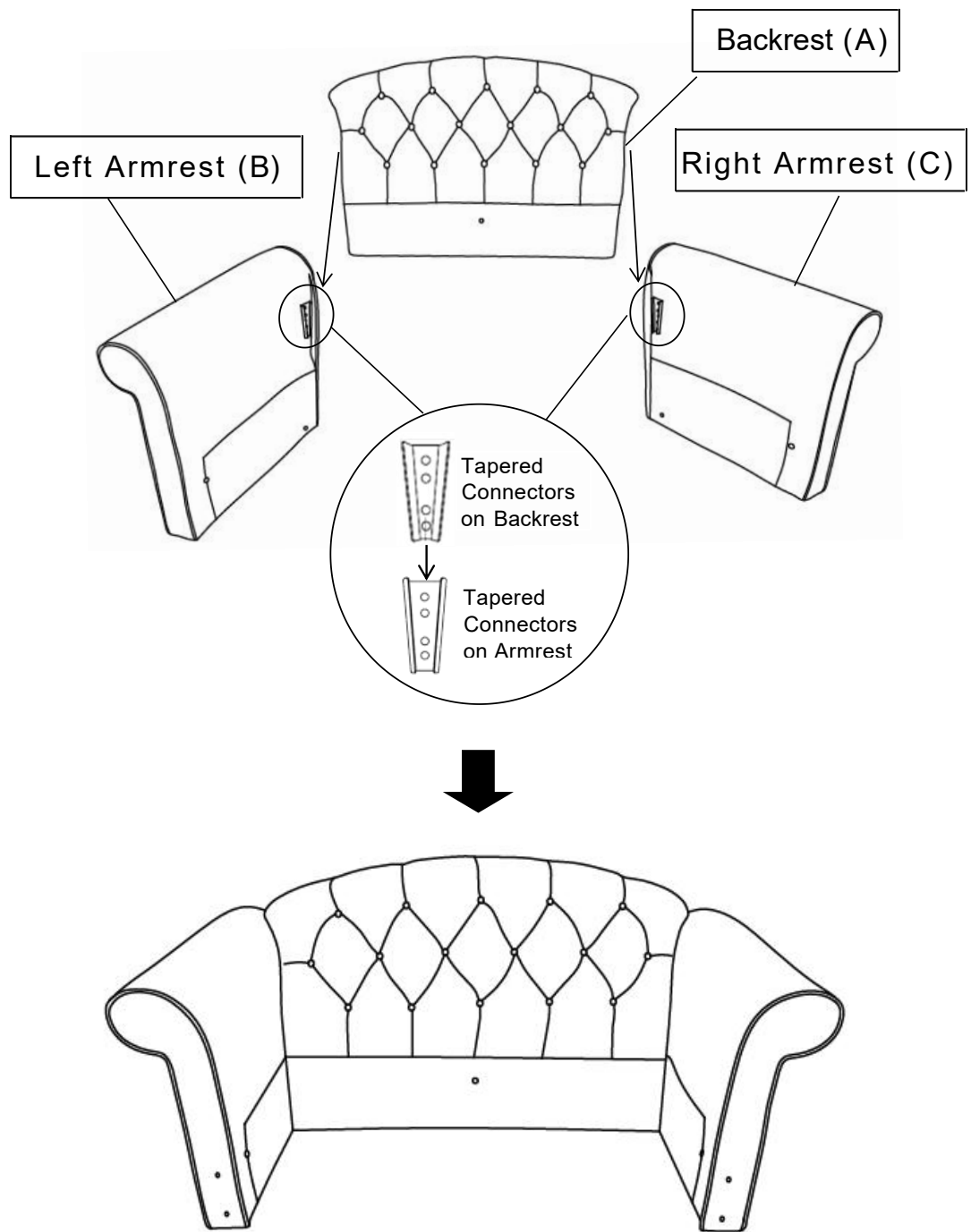

With the assistance from your adult partner:

1.1) Lift the Backrest(A) up, make sure the Backrest(A) is vertical and aligned to the Armrests.

Align the Tapered Connectors on the Backrest(A) with those on the Armrest(B&C).

Your adult partner may need to push the Armrests in towards the Backrest(A) to allow for better alignment.

Slip and Slide the Backrest, in a gradual and balanced manner into the Tapered Connectors.

1.2) Push the Backrest(A) downwards until it is fully slotted and locked into position.

**Note: Make sure the Tapered Connectors on the Backrest(A) lock into the Tapered Connectors on Armrest(B&C).**

**Fully locked position: Check and assess that the base of the Backrest(A) and Armrest(B&C) are aligned and level.**

## Step 5

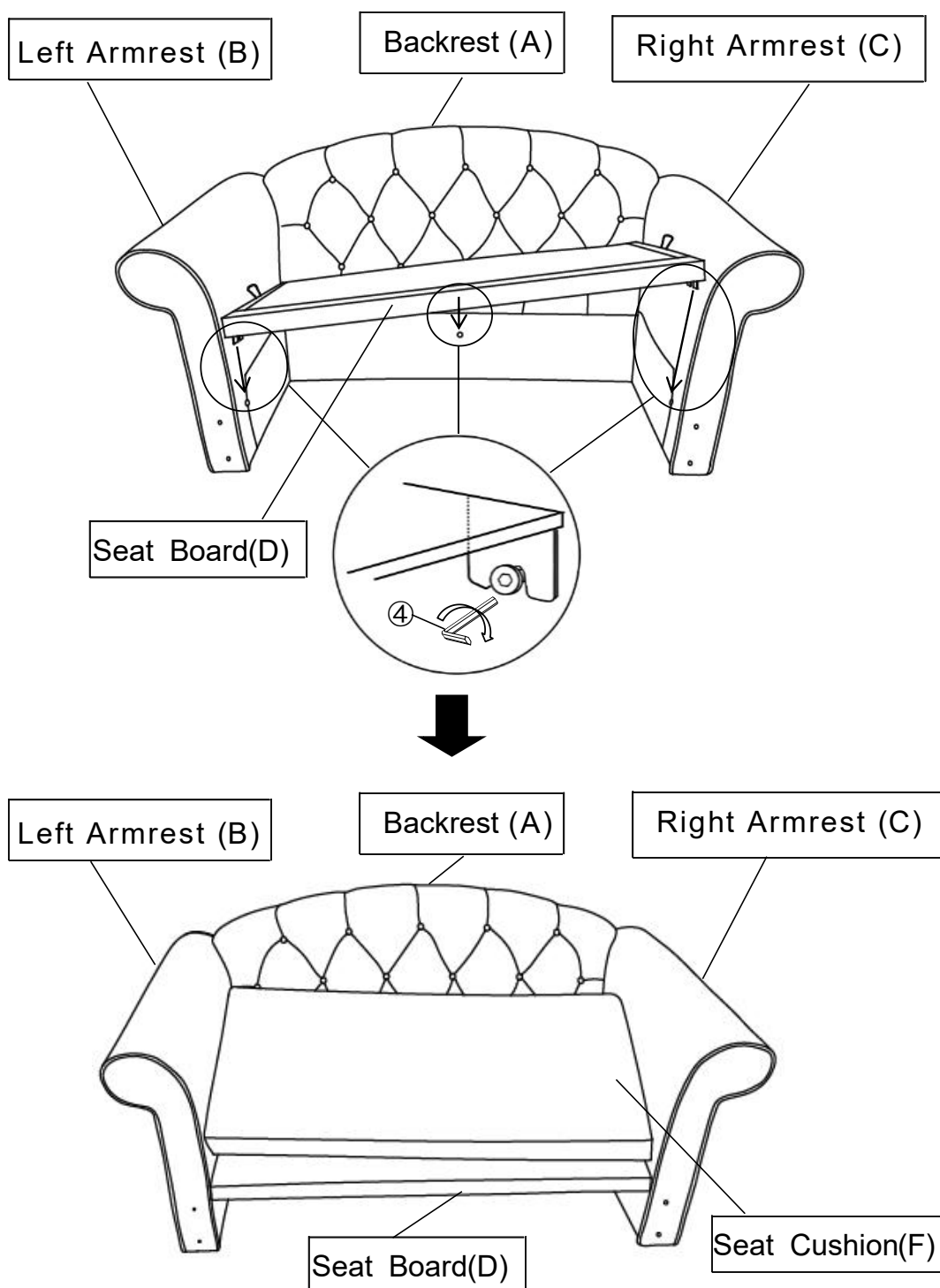

Put the Seat Board (D) onto the semi-assembled parts of step 5 as shown in the above pictures. Insert the brackets on the board onto the Bolts.

Use the Allen Wrench (④) and turn Clockwise to tighten the Bolts, ensure the brackets are tightly fitted onto the Bolts.

**Note: Make sure Step 5 is correctly acted, then do this step.**

Put the Seat Cushion (F) onto the Seat Board(D) as shown in the above pictures.

## Step 6

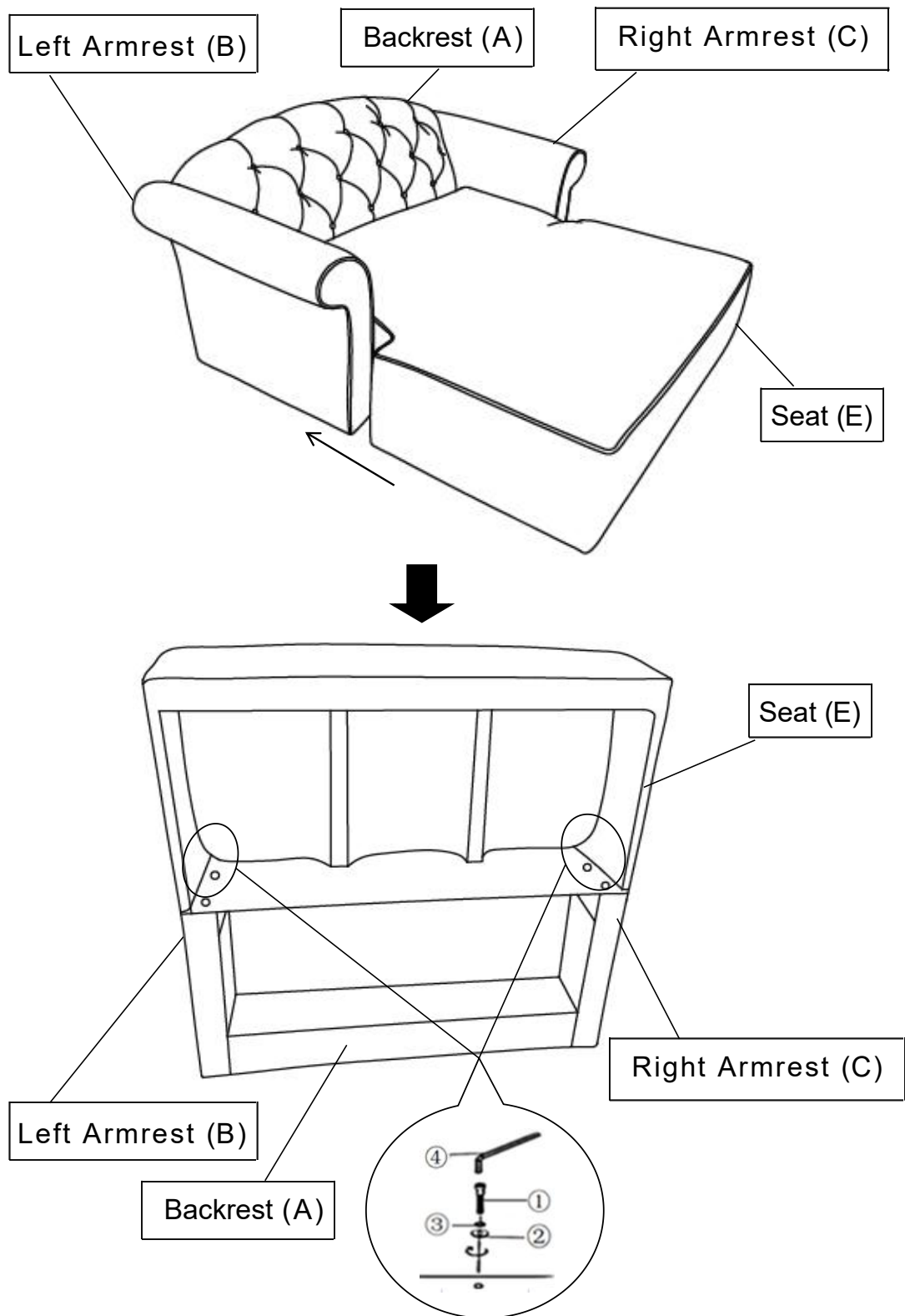

Turn the assembled Backrest as picture shown.

Attach Seat(E) to the semi-assembled product(STEP6) using Bolts(①), Washers(②) and Spring Washer(③) with the Allen Wrench (④) as pictured above.

Tighten the Bolts fully in a sequential manner.

**DO NOT fully tighten a Bolt in one go and then move on to the next.**

**Rather, In a sequential manner, gradually tighten each Bolt until all Bolts are evenly secured.**

## Step 7

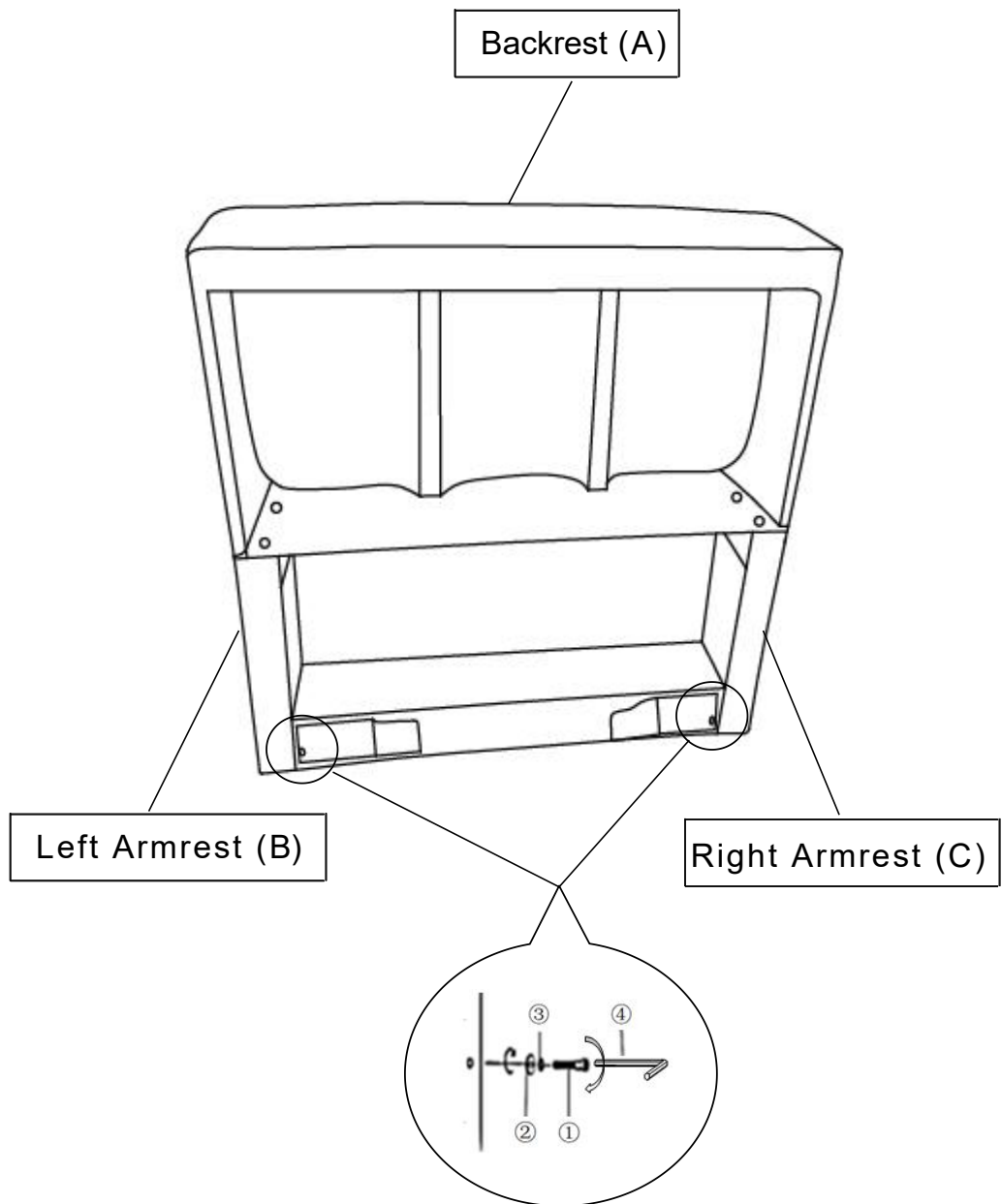

Turn the assembled Backrest and Armrest as picture shown.  
Using Bolts(①), Washers(②) and Spring Washer(③) with the Allen Wrench (④) as pictured above.

Tighten the Bolts fully in a sequential manner.

**DO NOT fully tighten a Bolt in one go and then move on to the next.**

**Rather, In a sequential manner, gradually tighten each Bolt until all Bolts are evenly secured.**

## Step 8

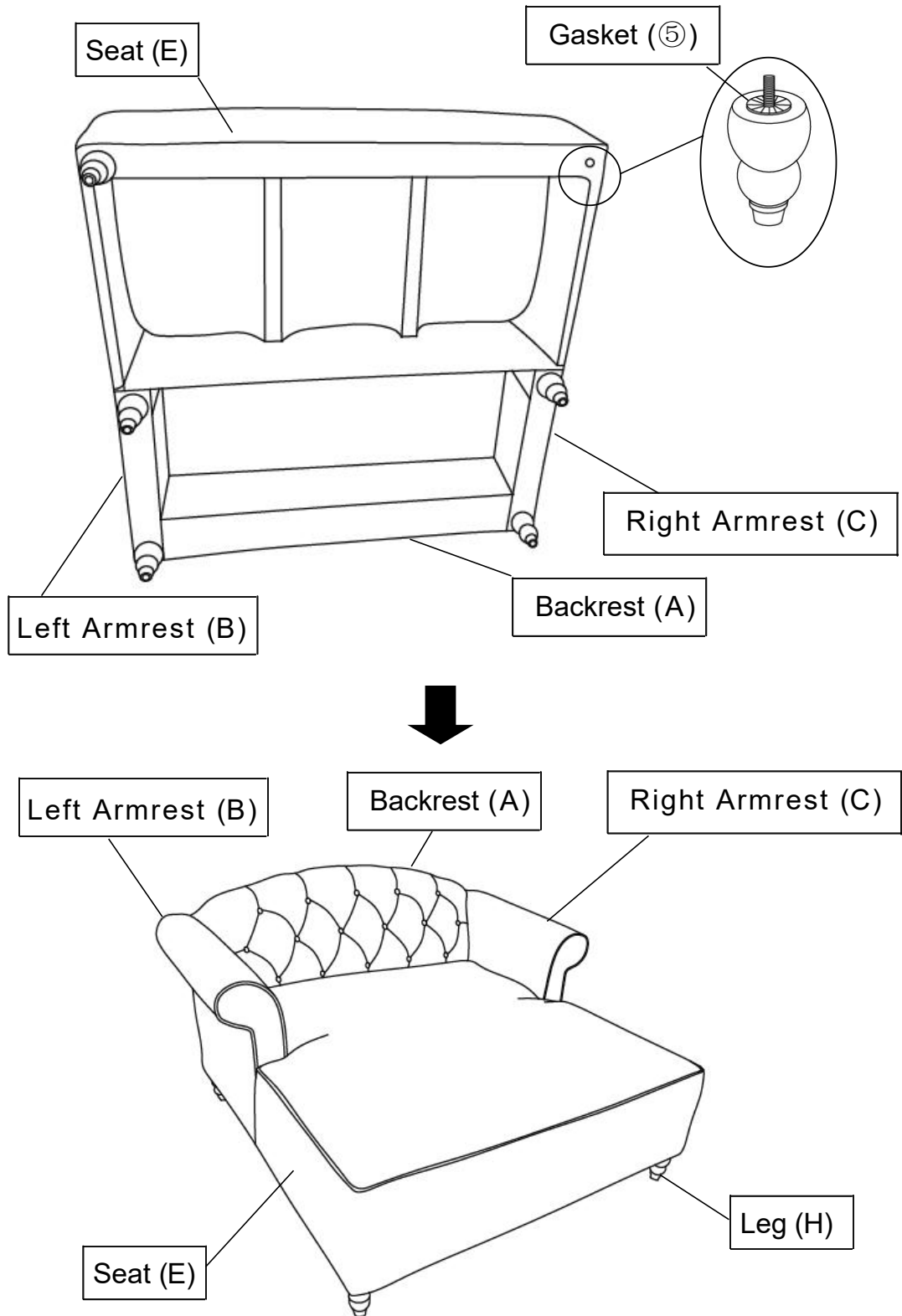

Install the Leg (H) onto the bottom of the Loveseat Chaise Lounge by placing one Gasket(5) on the threaded stem.

Then insert the threaded stem into the threaded mounting position at the corner of the Loveseat Chaise Lounge.

Tighten by turning the Leg clockwise.

Repeat this process with the remaining other Legs.

**Note: The use of Gaskets are OPTIONAL and are especially useful to help alleviate slight wobble.**

**Some Legs may need more than one whilst some legs may not need any.**

Step 9



Place the Pillows(G) onto the Loveseat Chaise Lounge.  
Your Loveseat Chaise Lounge is ready for use.  
This Loveseat Chaise Lounge can only be used on a flat, level surface.