

PROBRITE®

LED SECURITY FLOOD LIGHT

Catalog No. : PWRFX110-PC-4K-BZ

Type : Flood Light

Project Name :

Location :

Qty :

Date :



PROBRITE's PowerFlood X LED flood light boasts an impressive 12000 Lumens using only 100-watts, delivering a bright 4000K, effectively illuminating large spaces and photocell technology, making this a true dusk to dawn outdoor light. This powerful LED flood light is engineered to offer customers a whole new level of brightness to your outdoor space. Additionally, PROBRITE's PowerFlood X is made of die-cast aluminum and coated with industrial-grade powder coat bronze finish paint which gives durability and reliability to the fixture.

PRODUCT PERFORMANCE AT A GLANCE

SYSTEM WATTAGE	LUMENS	LPW	CRI	REPLACES (Incandescent)
110W	12000 lm	120 lm/w	>70	800W



DUSK-TO-DAWN

HOUSING

Die cast aluminum housing with corrosion resistant powder-coated paint finish. It is designed to ensure cooling by natural convection and passive airflow, to let driver perform efficiently

IP RATING & LISTINGS

LED light engine is weather proof and water tight rated as IP65, UL Listed, and DLC premium

OPTICS

Clear glass lens, does not alter beam and provide focused and clear lighting output.

MOUNTING

It can be mount on wall or eave with plate attached to any junction box. It can be mount on ground as well with 1/2" NPSM pipe thread (Sold separately).

FINISH

Fade, weather, and abrasion resistant, electrostatically applied, thermally cured, triglycidal isocyanurate (TGIC) textured polyester powdercoat bronze paint finish.

WARRANTY

Covered by a 5-year limited warranty. See probrite.com/warranty for details.

PRODUCT SPECIFICATION

Product Dimensions	: 4.74" x 11.74" x 11.66"
Weight	: 8.27 lbs
Lumens	: 12000
LED Wattage	: 100W
Efficacy	: 120W
CRI	: >70
Replaces (Incandescent)	: 800W
Mounting	: Wall/Eave/Ground Mount
Frequency	: 50-60Hz
THD (Total Harmonic Distortion)	: <20%
PF(Power Factor)	: >0.9
Ambient Operating Temperature	: (-30)-40°C
Input Voltage	: 120-277V
LED Chip	: -
Photocell	: Yes
Driver	: Dimming
Standard Lifetime	: 50,000 hrs
Standard Warranty	: 5 Years
Water Proofing Grade	: IP65
CCT	: 4000K Bright White Light
Certifications	: IP65, FCC Certified, UL Certified, DLC Premium

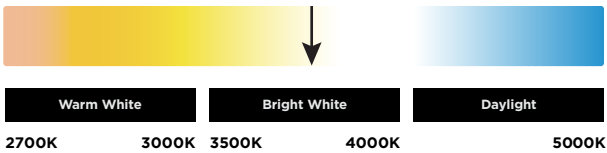

SUGGESTED MOUNTING HEIGHT:
6-12 FT.(1.8-3.7 M)

3D PHOTOMETRIC VIEW

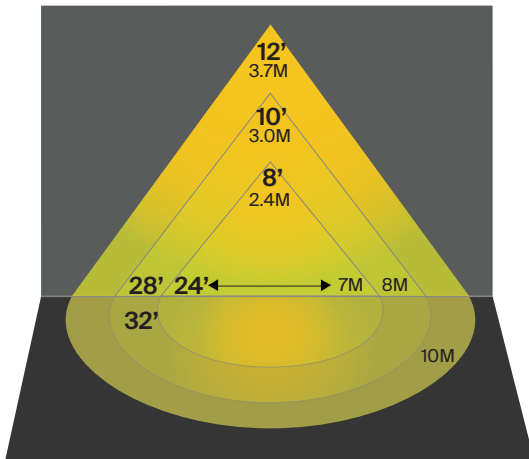

PRODUCT LINE DRAWING

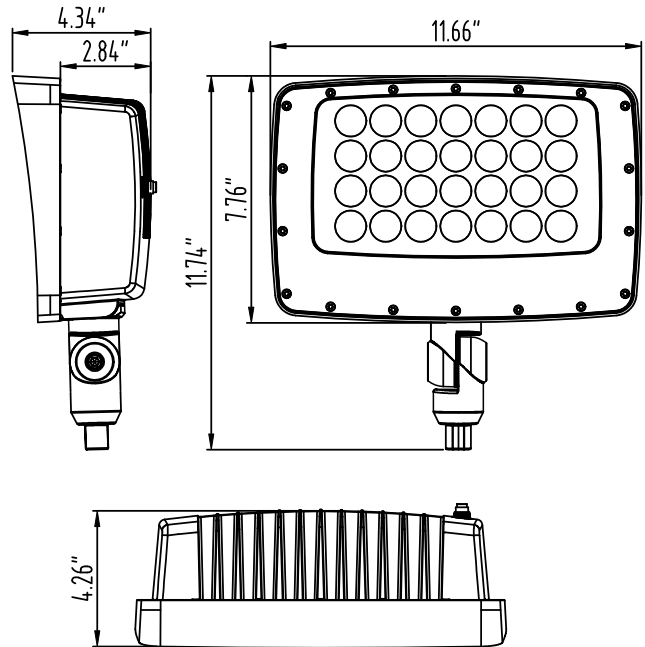

APPLICATION

SUITABLE FOR MULTIPLE APPLICATIONS

- WAREHOUSES • LOADING BAYS • PATIOS
- COMMERCIAL PARKS • APARTMENT COMPLEXES

