

Item#	Qty	Description	MATERIAL
1	1	TOP ASSEMBLY	WOOD
2	5	DRAWER ASSEMBLY	WOOD, METAL
3	1	BASESTRIP ASSEMBLY	WOOD
4	2	PILASTER	WOOD
5	1	WAIST MOULDING	WOOD
6	1	WAIST RAIL	WOOD
7	10	FELT PAD	FABRIC
8	2	CHANNEL MOULDING	PLASTIC
9	5	RIGHT CABINET GLIDE	METAL, PLASTIC
10	5	LEFT CABINET GLIDE	METAL, PLASTIC
11	1	TIPPING RESTRAINT	PLASTIC
12	5	HANDLE	METAL
13	20	GLIDE SPACER	PLASTIC

Scale: 1:15	TOLERANCES ARE: METRIC:..... +.5 / -.5mm DECIMAL:..... 0 / -.008" FRACTIONAL:..... +0/ -1/32" (UNLESS OTHERWISE SPECIFIED)		
Desc: Chest			
Rev.:	Description	Date	Cad/Eng

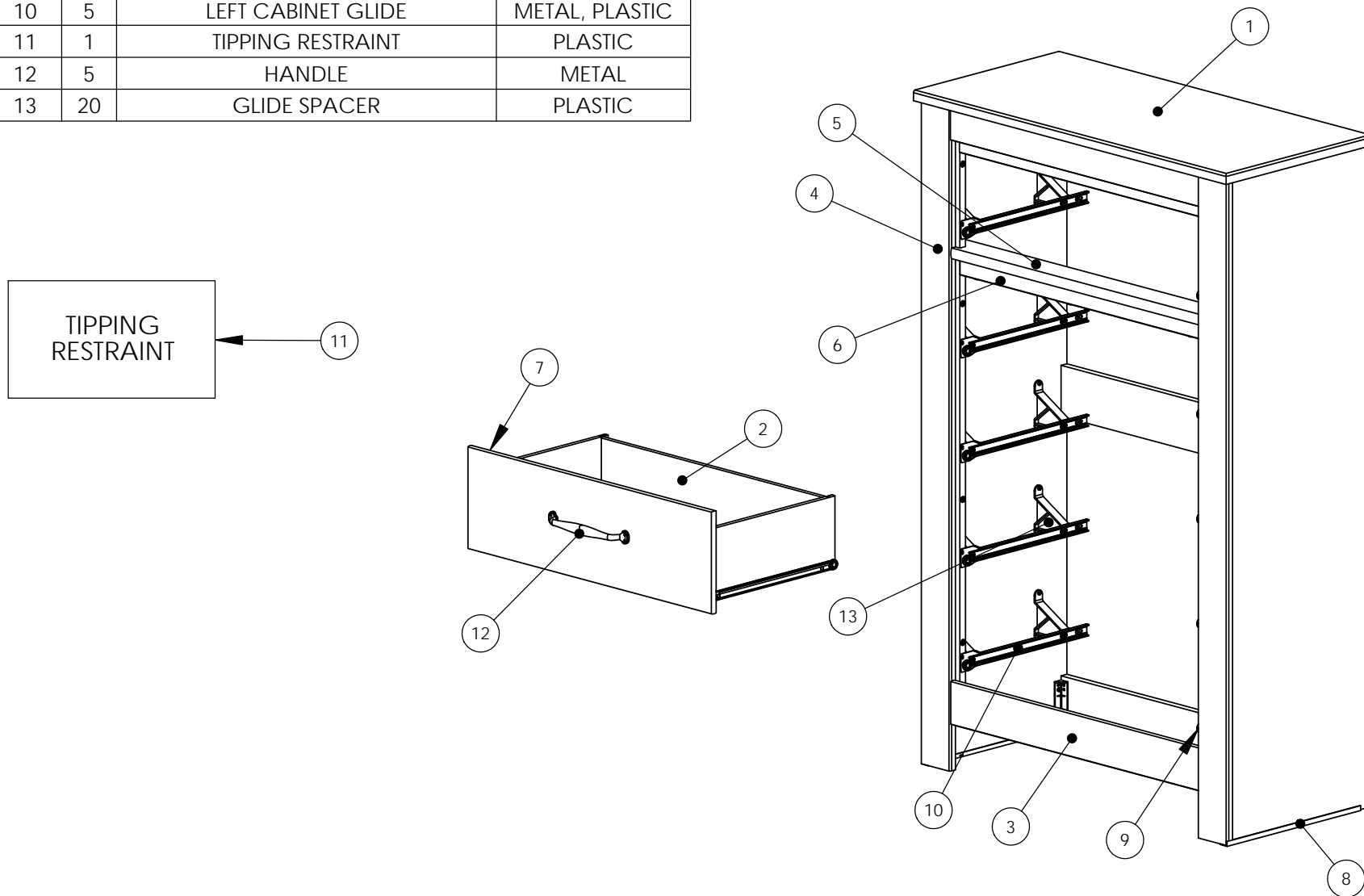

TIPPING RESTRAINT

11