



Specification Information

Product Code: 400-14A-BLK

Product Name: Stainless Steel Combination Dispenser/Disposal, 4.5" Depth, Recessed

Individual Carton UPC: 624622400125

Individual Carton Shipping Dimensions: 36.8cm W x 147.3cm H x 16.5cm D (14.5" W x 58" H x 6.5" D)

Individual Carton Shipping Weight: 18.1kg (40 lbs)

Site Location: Frost code 400-14A-BLK stainless steel combination dispenser/disposal is Frost's largest combination fixture and is ideal for high volume areas with shallow wall depth. Typically, these units are used in schools/universities, restaurants, malls, office buildings, condominiums, fitness facilities, and recreation centres. The stainless steel construction and professional matte black finish appearance make it a popular choice in high traffic areas.

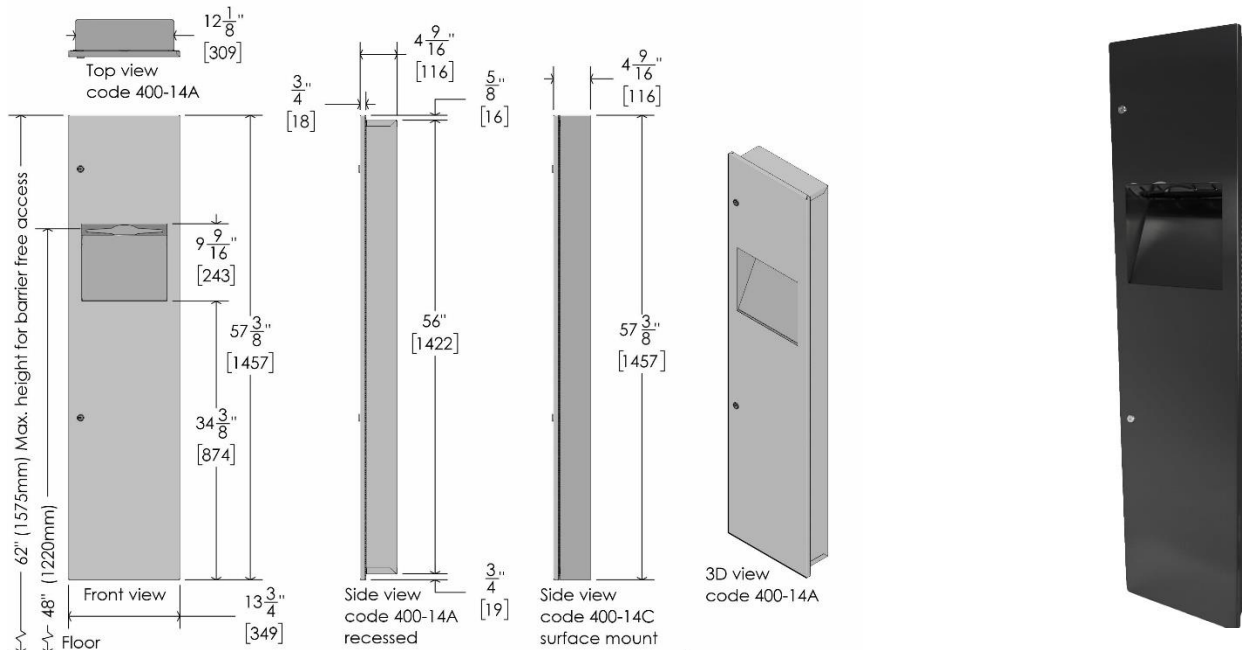

Features:

- Made with 18 & 20 gauge Canadian stainless steel
- Stainless steel (safety guarded) saw tooth cutting bar
- Secured with two tumbler keyed lock, keys provided
- All doors are hinged with full length stainless steel piano hinges
- Counterbalanced stainless steel door (20 gauge) provides maximum fire protection, mounted with full length piano hinge
- Removable leak proof steel liner

Dispensing: Frost's 400-14 series will dispense multifold or "C" fold paper towels. This product is designed to be universal; meaning, the unit is non-proprietary and dispenses paper from standard commercial paper producers. This allows the end user to avoid getting locked into paper supply contracts and should save them money on their janitorial supplies. The unit is manually operated and can be refilled by unlocking the dispenser from the top and bottom. The door will then pivot open and new paper can be inserted.

Frost Products Ltd

5276 John Lucas Drive
Burlington, ON, Canada, L7L5Z9

(905) 332-5700
1-800 667-5094

info@frostproductsltd.com
www.frostproductsltd.com



Specification Information

Capacity:

- 18 litre capacity (3.95 gal. imp., 4.75 gal. US)

Materials:

- Body: 18 gauge stainless steel, matte black finish
- Door: 20 gauge stainless steel type 304 matte black finish

Product Dimensions:

- 34.9cm W x 145.8cm H x 11.4cm D (13.75" W x 57.4" H x 4.5" D)

Product Weight:

- 18.1kg (40 lbs)

Installation Guidelines: Code 400-14A-BLK: provide 31.5cm wide x 143.2cm high x 11.4cm deep (12.4" W x 56.4" H x 4.5" D) wall opening. For unrestricted access, height of top of unit to floor must not exceed 157.5cm (62") or bottom of rough opening must not exceed 13.0 cm (5") in height from floor. Please note that it is recommended that all installations be conducted by a qualified tradesperson. Please read and follow any additional installation guidelines provided with the products. Failure to do so may result in serious injury or death.

Maintenance: Normal preventative maintenance and cleaning will keep Frost products functioning properly and may extend normal product life. Products should be wiped down with a damp soft cloth periodically. Approved stainless steel cleaner may be used to clean scuffs or fingerprints on stainless surfaces. Do not use harsh detergents or chemical cleaners. For stainless steel please do not spray with any product containing bleach, acids, or chlorides, which can be found in many cleaning products such as toilet bowl cleaners. Use of these cleaning solutions may cause discoloration and if used for prolonged periods of time they can eat away at points in the stainless steel. If discoloration occurs, the use of an approved stainless steel cleaner and a firmer scrub pad, such as a Scotch Brite Pad #7447, may remove the markings. Wipe away any debris from the area and gently rub with the pad. Then spray the area with a stainless steel cleaner/polish and rinse and dry. Always wipe with the grain direction for stainless steel products. If a cleaning agent has begun to eat away at the steel on a unit then the unit will likely need to be replaced. The stainless steel that Frost Products uses is of high quality and stainless steel is resistant to rust. However, discoloration that appears to be rust can be caused by cleaning solutions and soaps mentioned above. It is important to discontinue use of any cleaning agent or soap if discoloration begins to occur. Clean off the discoloration as quickly as possible to avoid any permanent damage to the unit. Maintenance staff should be taught how to recognize the signs that they are not using the appropriate cleaning products and how to correctly maintain stainless steel items.

Warranty: If any product or part proves to be defective within 12 months from date of shipment from the factory it will be repaired or replaced without any charge including freight costs when authorized. Costs resulting from the installation or removal of defective products are not covered under this warranty. Discoloration to stainless steel parts resulting from exposure to harsh environmental and / or chemicals are not considered to be defects in workmanship or material and are not covered under warranty.