

ASSEMBLY INSTRUCTIONS

Read this instruction carefully. See hardware and furniture part list for guidance. Be sure all parts are complete, before you assemble. Place all wooden furniture parts on a clean and flat soft surface to prevent from being scratched. Follow the figure to start assembling.

CAUTIONS : 1. Do not FULLY - TIGHTEN the nut or nut bolt until all nut or bolt is ready assembled.
2. Do not OVER - TIGHTEN the nut or bolt to avoid causing damages to the thread.
3. Keep all hardware parts out of reach of children.

NOTE : THE LIST AND QUANTITY SHOWN ARE FOR 1 UNIT ASSEMBLY.

Tool needed : Screwdriver (not provider).

PART LIST		
ITEM	DESCRIPTION	QTY
A	HEADBOARD TOP	1 PC
B	HEADBOARD BOTTOM	1 PC
C	HEADBOARD WING	2 PCS
D	FOOTBOARD	1 PC
E	SIDE RAIL	2 PCS
F	CENTER RAIL	1 PC
G	CENTER SUPPORT LEG	3 PCS
H	CENTER RAIL SUPPORT	2 PCS
I	BED LEG	4 PCS
J	BED SLAT	26 PCS

HARDWARE LIST		
ITEM	DESCRIPTION	QTY
1	JCBC BOLT M6 x 20mm	8 PCS
2	JCBC BOLT M6 x 45mm	6 PCS
3	JCBC BOLT M8 x 45mm	4 PCS
4	M6 FLAT WASHER	14 PCS
5	M6 SPRING WASHER	8 PCS
6	M8 FLAT WASHER	4 PCS
7	M8 SPRING WASHER	4 PCS
8	WOOD DOWEL M8 x 30mm	4 PCS
9	WOOD SCREW M4 x 20mm	2 PC
10	WOOD SCREW 3.5 x 16mm	8 PCS
11	M4 ALLEN KEY (BALL SHAPE)	1 PC
12	M5 ALLEN KEY (BALL SHAPE)	1 PC
13	BED SLAT SIDE FITTER	26 PCS
14	BED SLAT CENTER FITTER	13 PCS

STEP 1

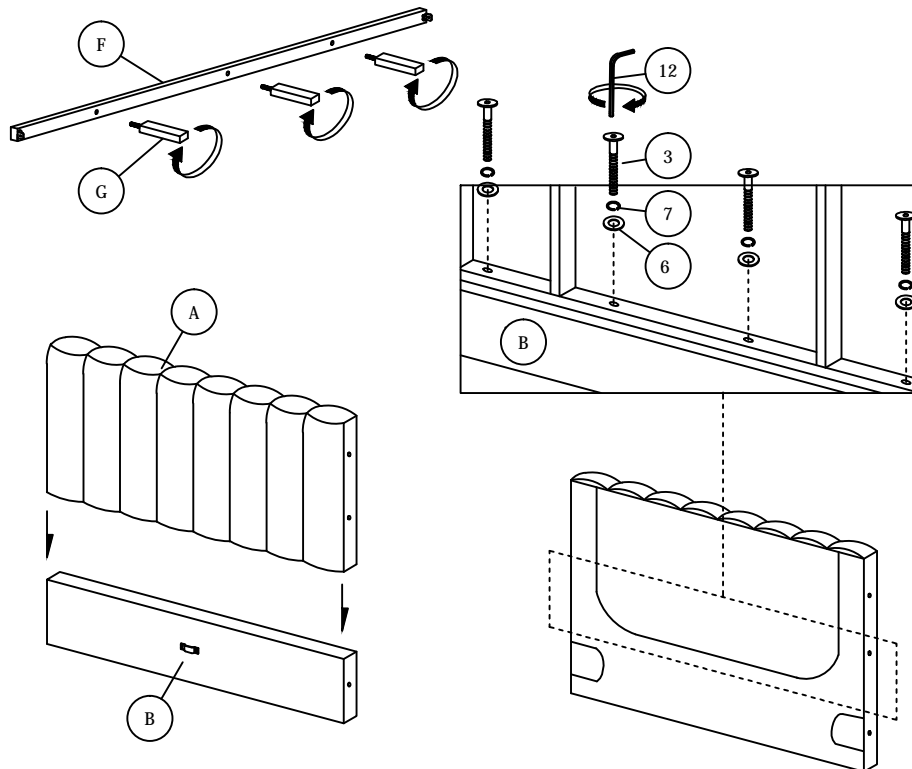

STEP 2

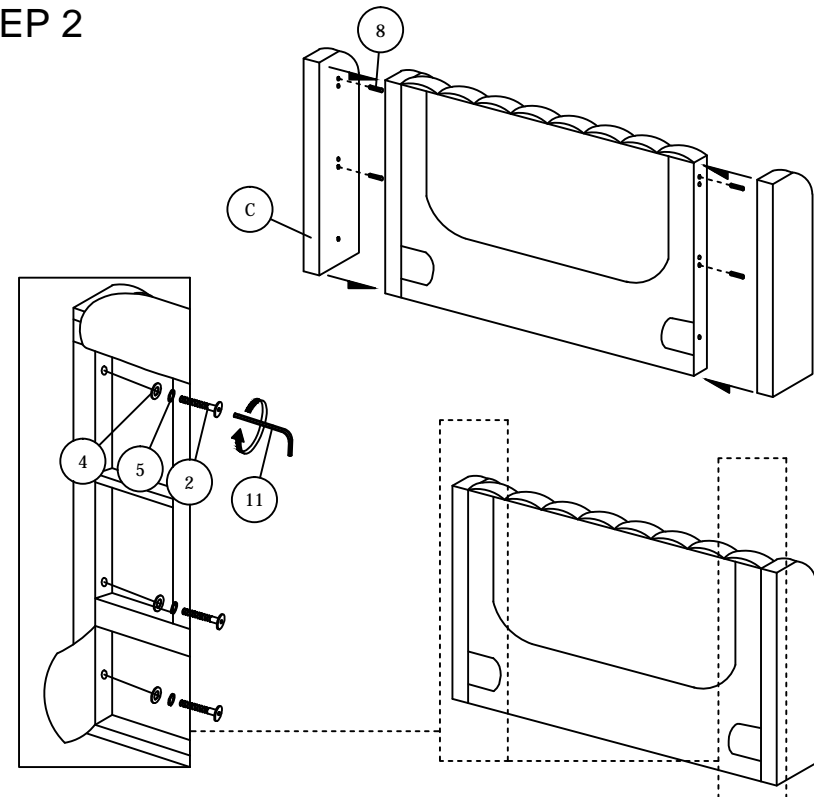

STEP 3

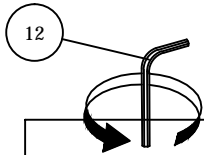

Loosen the pre-inserted bolt on the footboard using Allen key ball shape (12).

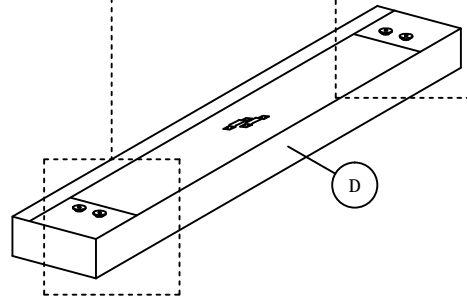
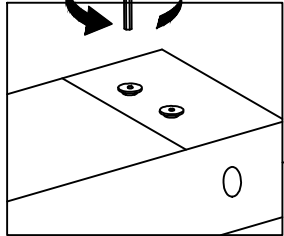

STEP 4

STEP 4.1

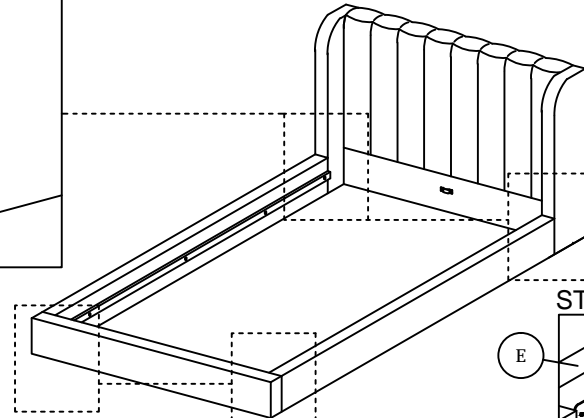
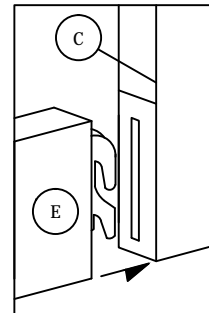

STEP 4.2

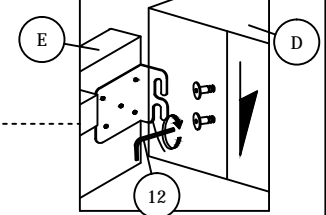

STEP 5

NOTE :

Make sure the floor is clean and smooth when put down the bed to prevent scratches.

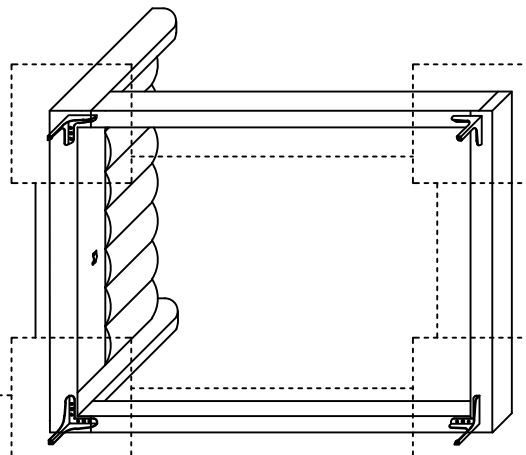
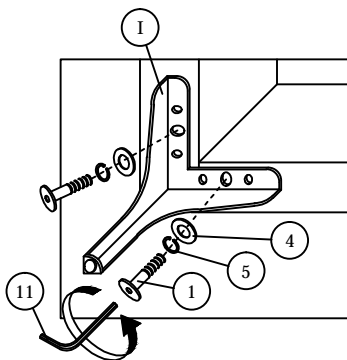

STEP 6

Note: Assemble (E) vertically as picture shown.

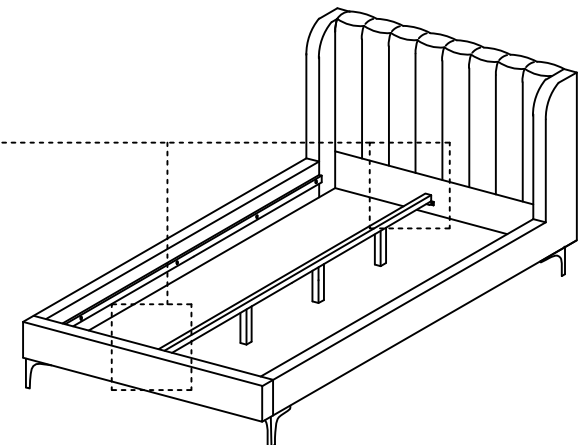
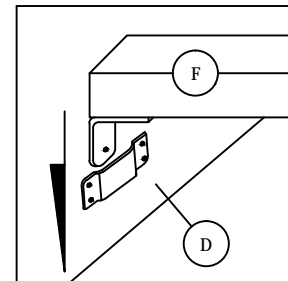

ASSEMBLY INSTRUCTIONS

STEP 7

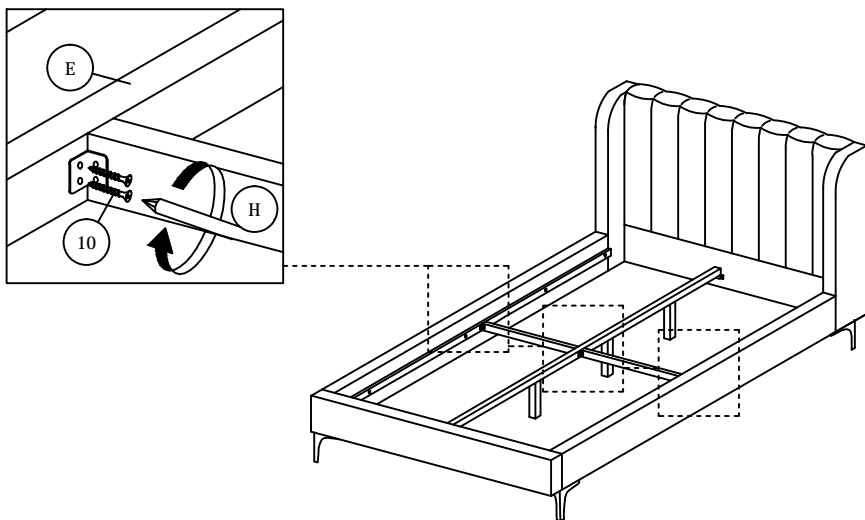

STEP 8

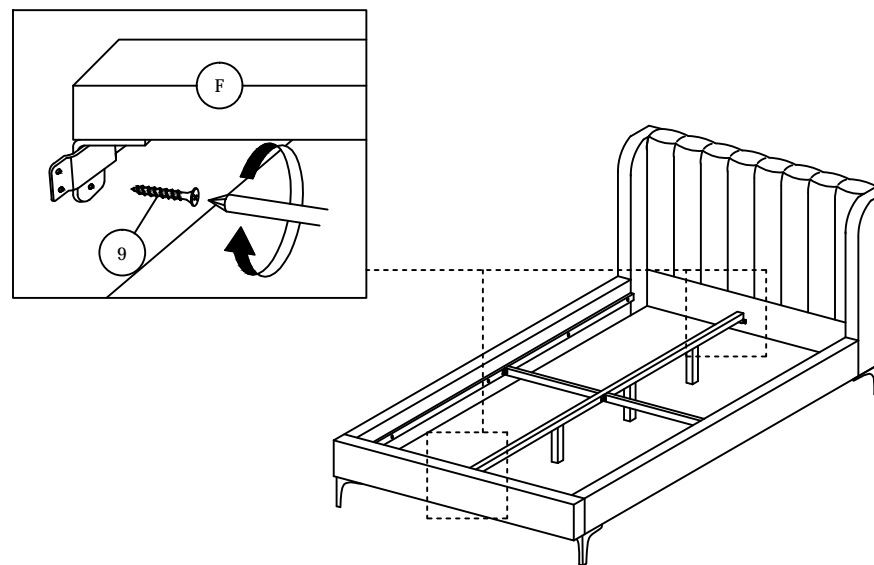

STEP 9

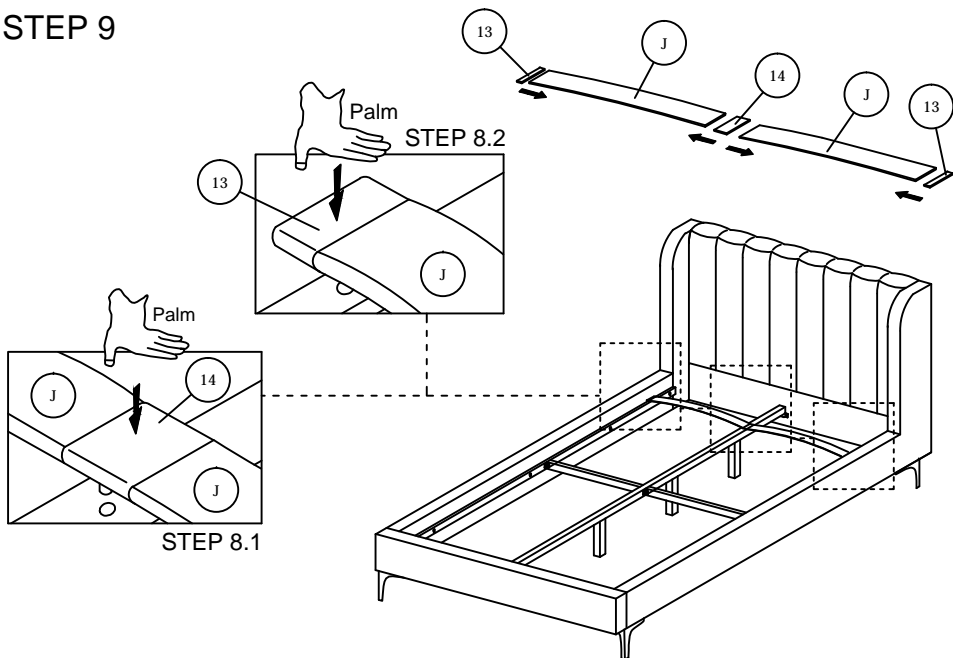

STEP 10

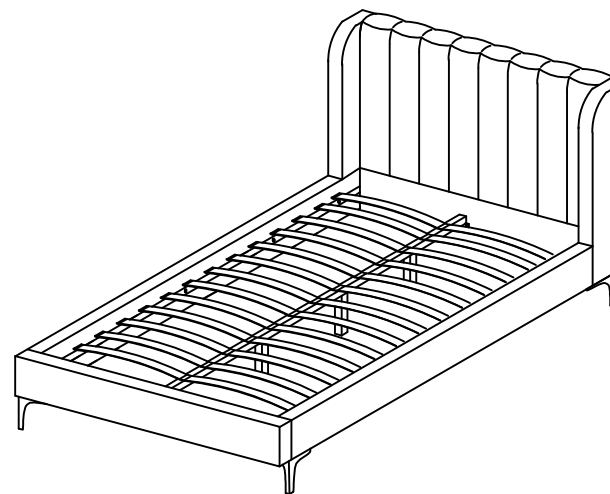

* When moving the bed position, the center support legs must be adjust to be straight to avoid any broken problem.