

Cage Assembly Instructions

CAGE COMPONENTS

1 Wire body	2 Metal Left Shelves	4 Wire Clips
1 Metal tray	2 Metal Right Shelves	4 Rolling Casters
1 Metal Stand	4 Metal Ramps	1 Wrench

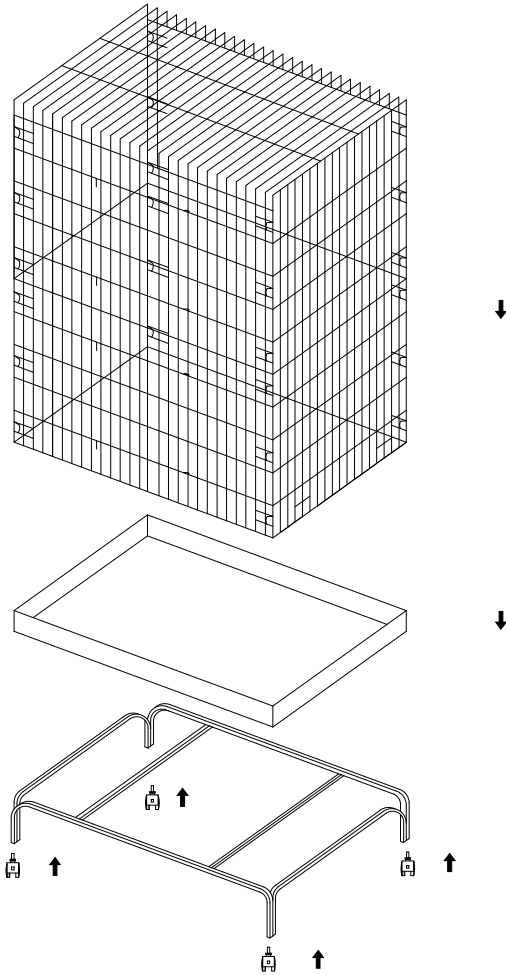

Step 1: Attach 4 Rolling Casters into Metal Stand by using Wrench, then put in the Tray and Wire Body as shown.

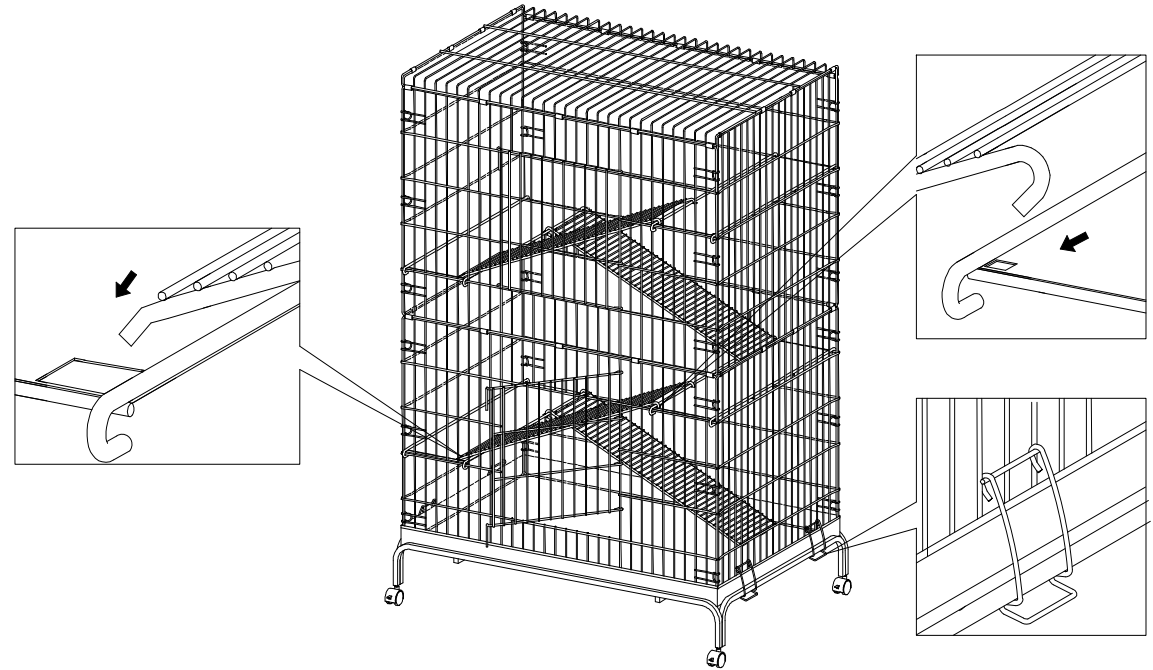

Step 2:

(1) Secure Wire Body to the Metal Stand by using Wire Clips as shown.

(2) Assemble Metal Shelves into cage as shown. *Important note:* when putting the shelves into the cage, the 2 Left Shelves have holes in the **right** side, and the 2 Right Shelves have holes in the **left** side.

(3) Assemble Metal Ramps into cage as shown. *Important note:* attach the ramps to the shelves by hooking the ramps onto the shelves by the curved ends. The straight ends of the ramps will fit into the next shelf.

Step 3: Now, your new cage is ready for use.