

NOTICE

- * Please make sure that you have all parts indicated and they are in good condition before you begin assembly of this item. Refer to part list and hardware list below for guidance.
- * This item should be assembled on a soft surface to prevent scratching the finish during assembly.
- * This item may require periodic tightening.
- * If you are having difficulty, our friendly Customer Care team is always here to help. Please email customersupport@safavieh.com

PREPARATION

- * Before beginning assembly of product, make sure all parts are present. Compare parts with part contents list and hardware contents list.
- * If any part is missing or damaged, do not attempt to assemble the product.
- * Estimated Assembly Time: 10 minutes.
- * Tools Required for Assembly (included): Allen Key

CARE AND MAINTENANCE

WOOD CARE: Adhesive felt pads should always be applied to areas of furniture which make direct contact with flooring, said application will prevent damage to the furniture and or surfaces on which the furniture lies. Objects placed on articles of furniture should rest on non abrasive material as to prevent damage to the wood finish. Objects whose composition consists of plastic and rubber are known to discolor and damage the wood surfaces on which they rest. Wipe up spills immediately and avoid common hazards such as hot dishes, harsh solvents and abrasives. Cleaning should be done with a soft lint free cotton cloth dampened with water or furniture polish. On highly used surfaces we recommend applying a quality paste wax which should be used on a regular basis to provide additional protection from scratches and spills. How often you apply the wax depends on how much wear the furniture receives.

UPHOLSTERY CARE: To prevent overall soiling, frequent vacuuming or light brushing is recommended. Cushions and pillows should be turned on a weekly basis. Down-filled cushions should be brushed rather than vacuumed. Spot clean, using a mild water-free solvent or dry cleaning product. Only a professional cleaner should undertake a complete overall cleaning. The use of steam or water-based cleaners may cause excessive shrinking or staining.







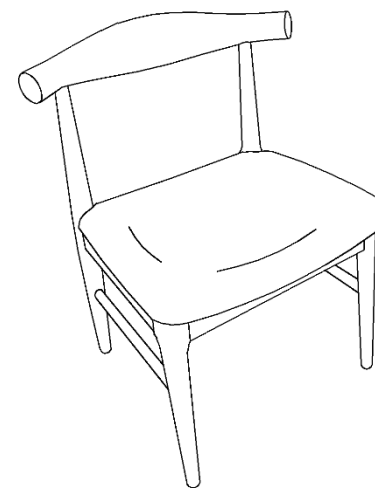



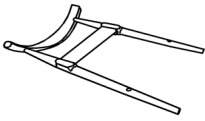

ITEM ID: DCH3301

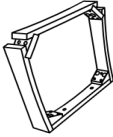
ITEM DIMENSION: W20.9"x D20.9"x H30.5"x SH18"

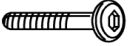
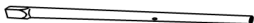
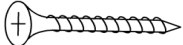

Weight Capacity : 225lbs
Warning : Do not stand on chair
Warning : Do not over torque bolts

Part List and Hardware List

PIECE	DESCRIPTION	PICTURE	QUANTITY	PIECE	DESCRIPTION	PICTURE	QUANTITY
A	Chair Back With Seat		1X	HW1	JCBC M6 x 80mm		4X
B	Box Seat		1X	HW2	JCBC M6 x 60mm		4X
C	Left Leg (FL)		1X	HW3	JCBC M6 x 35mm		2X
D	Right Leg (FR)		1X	HW4	CSK 32mm		9X
E	Strecher		2X	HW5	Spring Washer		10X
F	Seat		1X	HW6	Flat Washer		10X
				HW7	Allen Key M4 x 110mm		1X

PREPARATION

- * Before beginning assembly of product, make sure all parts are present. Compare parts with part contents list and hardware contents list.
- * If any part is missing or damaged, do not attempt to assemble the product.
- * Estimated Assembly Time: 10 minutes.
- * Tools Required for Assembly (included): Allen Key

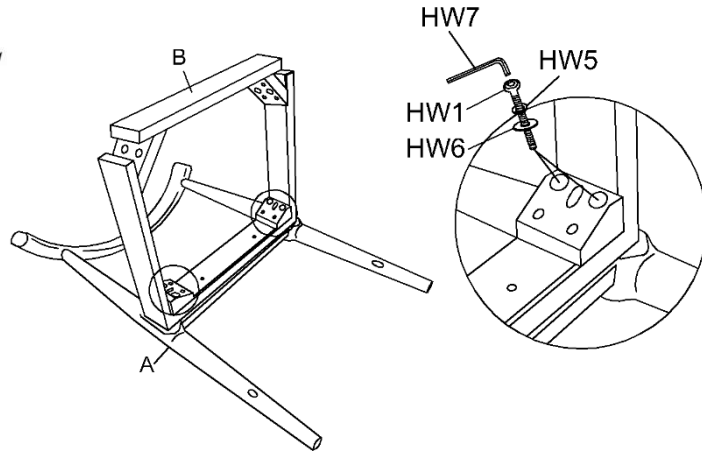

Step 1: INSERT JCBC (HW1) IN CORNER BLOCK AT BOX SEAT (B) TO ATTACH THE BACKREST (A) BUT DO NOT FULLY TIGHTEN THE JCBC COMPLETELY.

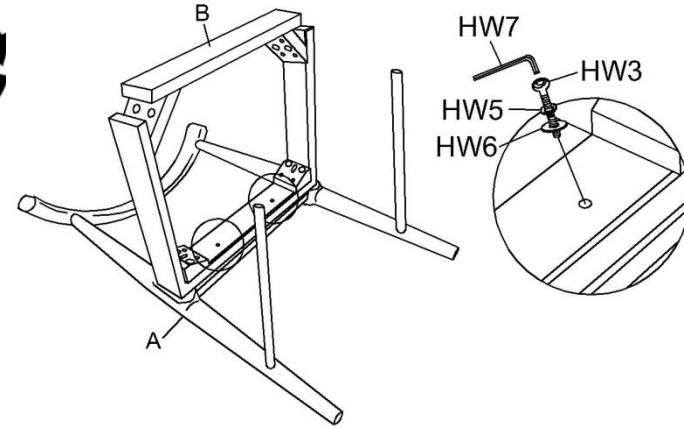

Step 2: INSERT JCBCW (HW3) TO ATTACH BOX SEAT (B) THEN TIGHTEN COMPLETELY STEP 1 AND STEP 2.

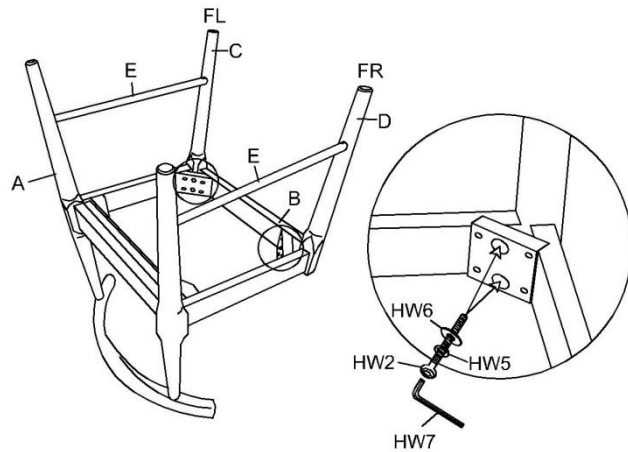

Step 3: INSERT JCBC (HW2) IN CORNER BLOCK AT BOX SEAT (B) TO ATTACH RIGHT LEG (D) AND LEFT LEG (C) BUT DO NOT FULLY TIGHTEN THE JCBC COMPLETELY.

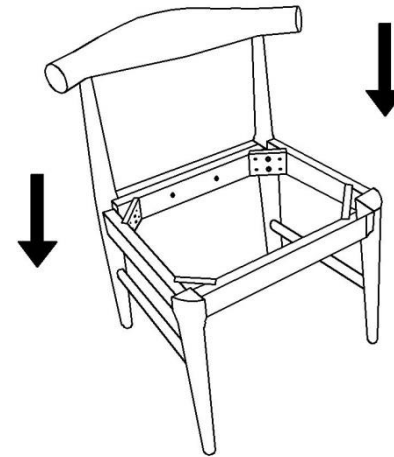

Step 4: FLIP THE CHAIR ON THE FLAT FLOOR TO ADJUST THE LEVELING BEFORE TIGHTEN THE BOLTS.

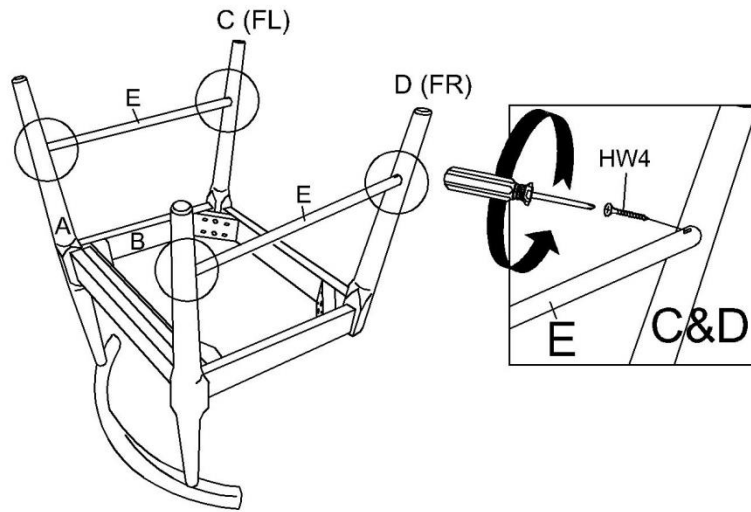

Step 5: INSERT CSK SCREW (HW4) TO TIE STRETCHER (E) TO LEFT LEG (C) AND RIGHT LEG (D) THEN TIGHTEN COMPLETELY STEP 3, STEP 4 AND STEP 5.

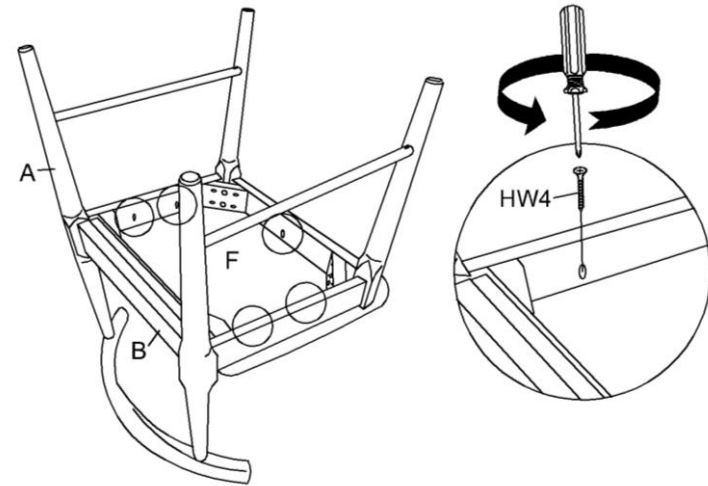

Step 6: INSERT CSK SCREW (HW4) TO TIE SEAT (F) TO BOX SEAT (B). FULLY TIGHTEN THE BOLTS.

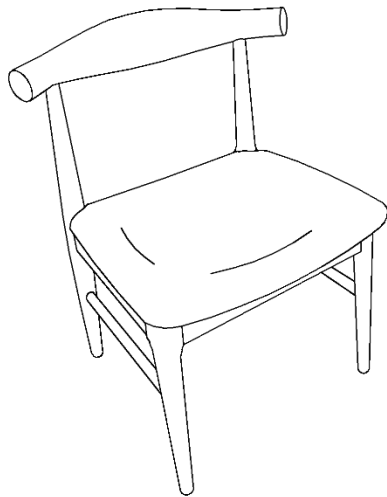

Step 7: PUT THE CHAIR UP RIGHT AND MAKE SURE ALL LEGS ALL ARE LEVEL, THEN FIRMLY TIGHTEN BOLTS WITH ALLEN KEY (HW7) WHILE THE CHAIR IS UPRIGHT.