

ASSEMBLY INSTRUCTION

SIDEBOARD

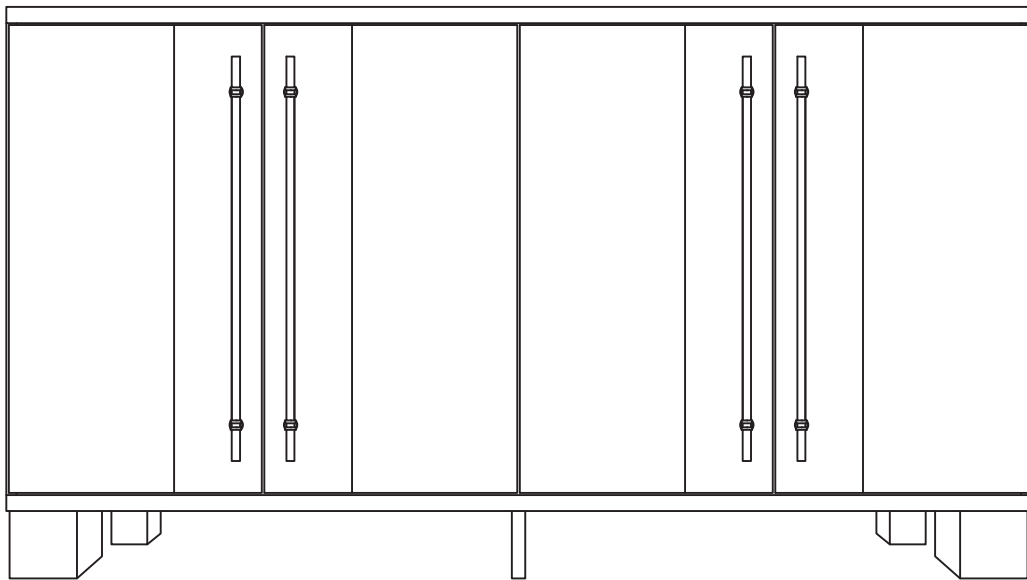

ASSEMBLY INSTRUCTION

Please read these instructions fully before starting assembly :

Tools required: Phillips screwdriver (medium & large)

1. Check you have all the components and tools listed on the following pages.
2. Remove all fittings from the plastic bags and separate them into their groups.
3. Keep children and animals away from the work area, small parts could choke if swallowed.
4. Make sure you have enough space to layout the parts before starting.
5. During assembly do not stand or put weight on the product, this could cause damage.
6. Assemble the item as close to its final position (in the same room) as possible.
7. Assemble on a soft level surface to avoid damaging the unit or your floor.
8. Parts of the assembly will be easier with 2 people.
9. To reduce the likelihood of damaging your product please ensure that your power drill is set on a low torque setting.
10. Assemble all parts and bolts loosely during assembly, only once the product is complete should you fully tighten the bolts.
11. Regularly check and ensure That all bolts and fittings are tightend properly.
12. Please do not place items that exceed the load capacity.

Care and maintenance

Only clean using a damp cloth and mild detergent, do no use bleach or abrasive cleaners.



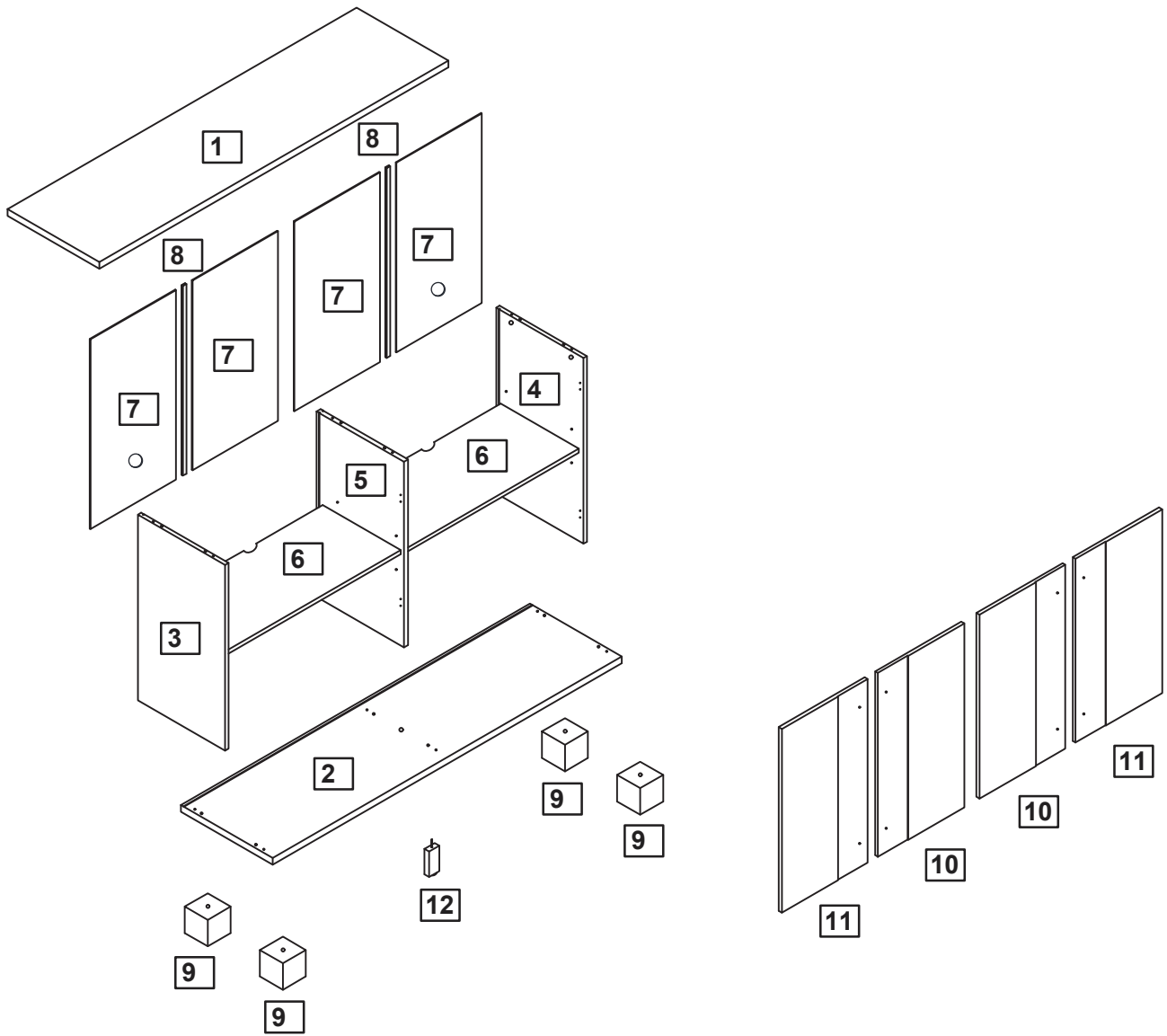



ASSEMBLY INSTRUCTION

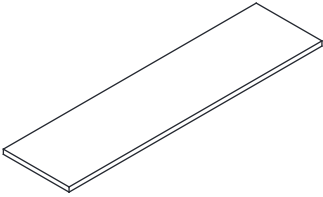
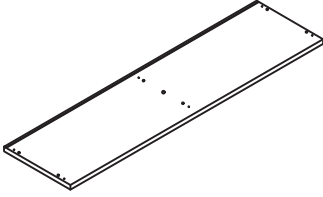

Part List

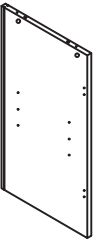
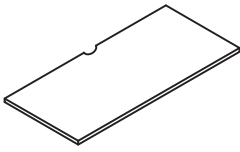
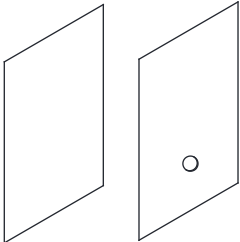
Please check you have all the panels listed below



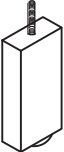







Note: The quantities below are the correct amount to complete the assembly. In some cases more fittings may be supplied than are required.

<p>①</p>  <p>Top Panel 1 PC</p>	<p>②</p>  <p>Bottom Panel 1 PC</p>	<p>③</p>  <p>Left Panel 1 PC</p>	<p>④</p>  <p>Right Panel 1 PC</p>
<p>⑤</p>  <p>Medial panel 1 PC</p>	<p>⑥</p>  <p>Center Shelf 2PCS</p>	<p>⑦</p>  <p>Back Panel 4 PCS</p>	<p>⑧</p>  <p>Rear connector 2PCS</p>
<p>⑨</p>  <p>Foot 4 PCS</p>	<p>⑩</p>  <p>Door 2 PCS</p>	<p>⑪</p>  <p>Door 2 PCS</p>	<p>⑫</p>  <p>Neutral position 1 PC</p>

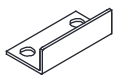
Hardware list

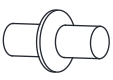
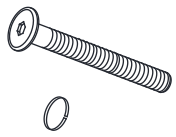
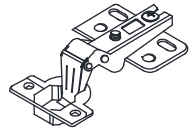
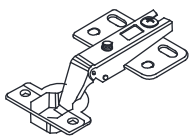
Please check you have all the panels listed below

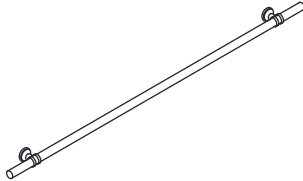

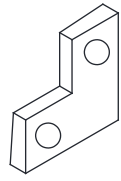



Note: The quantities below are the correct amount to complete the assembly. In some cases more fittings may be supplied than are required.

<p>A</p>  <p>Male Camlock x 6</p>	<p>B</p>  <p>Female Camlock x 6</p>	<p>C</p>  <p>Dowel x 12</p>	<p>D</p>  <p>4*50mm Screw x 6</p>
<p>E</p>  <p>E x 1</p>	<p>F</p>  <p>collision x 2</p>	<p>G</p>  <p>3*16mm Screw x 20</p>	<p>H</p>  <p>H x 1</p>
<p>I</p>  <p>Shelf Support Pin x 8</p>	<p>J</p>  <p>JCBC + Washer x 4</p>	<p>K</p>  <p>Door Hinge x 4</p>	<p>L</p>  <p>Door Hinge x 4</p>
<p>M</p>  <p>3.5*16mm Screw x 48</p>	<p>N</p>  <p>Handle x 4</p>	<p>O</p>  <p>4*18mm Screw x 8</p>	<p>P</p>  <p>Plastic edge x 8</p>

Hardware list

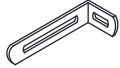
Please check you have all the panels listed below

Note: The quantities below are the correct amount to complete the assembly. In some cases more fittings may be supplied than are required.

					
		M4*30mm 	M3*12mm 		
Q ₁	Q ₂	Q ₃	Q ₄	Q ₅	
Wall Fixing Pack x 2					

ASSEMBLY INSTRUCTION

Step 1

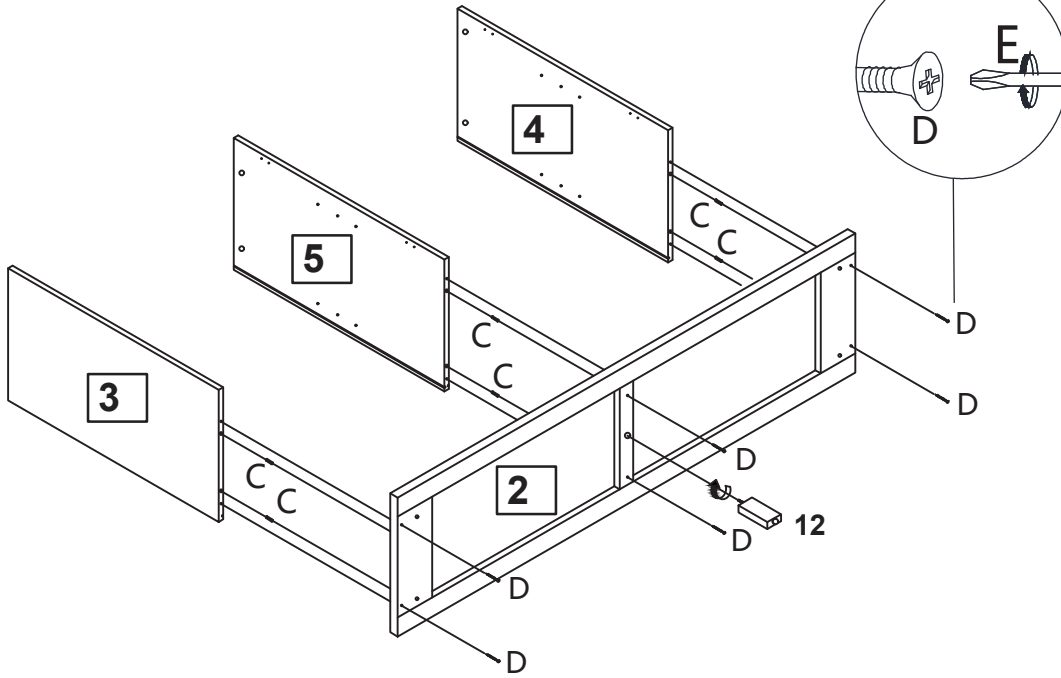

Step 2

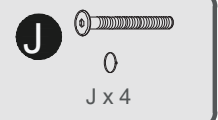
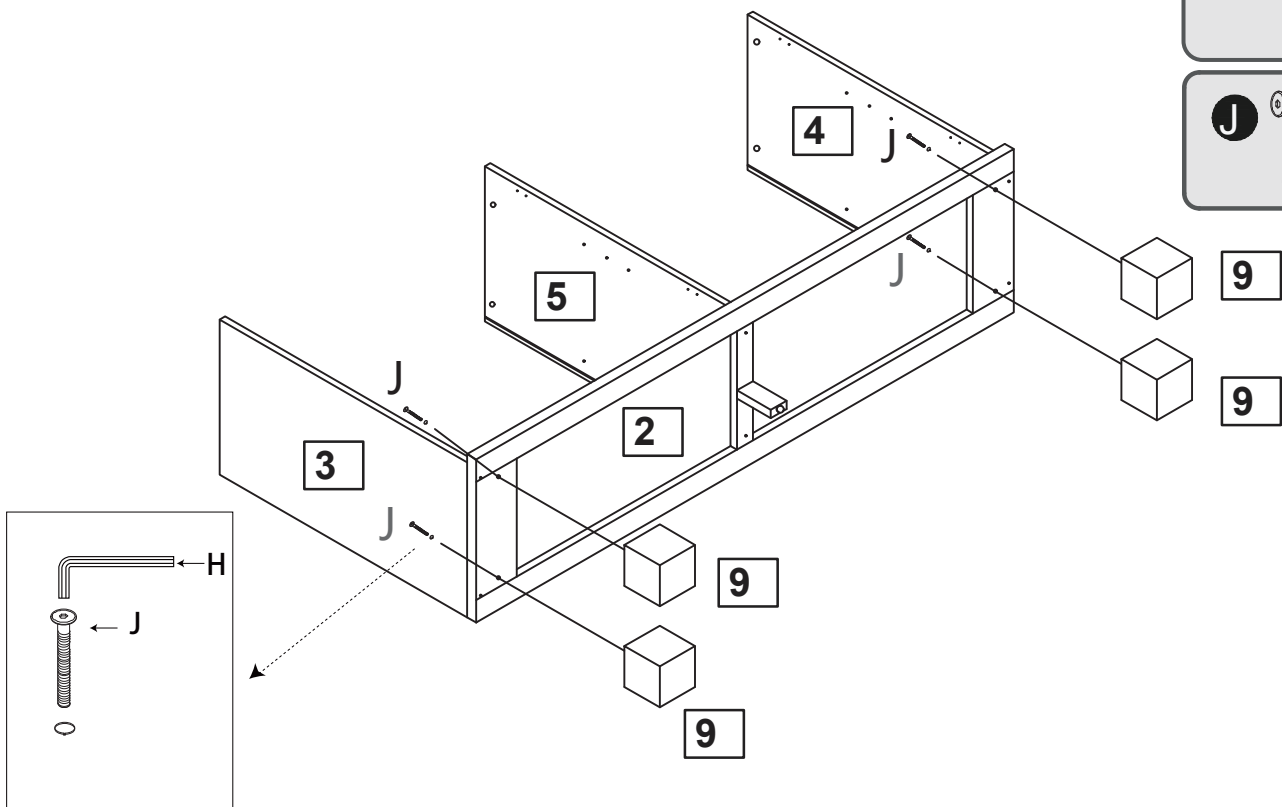

9

9

9

9

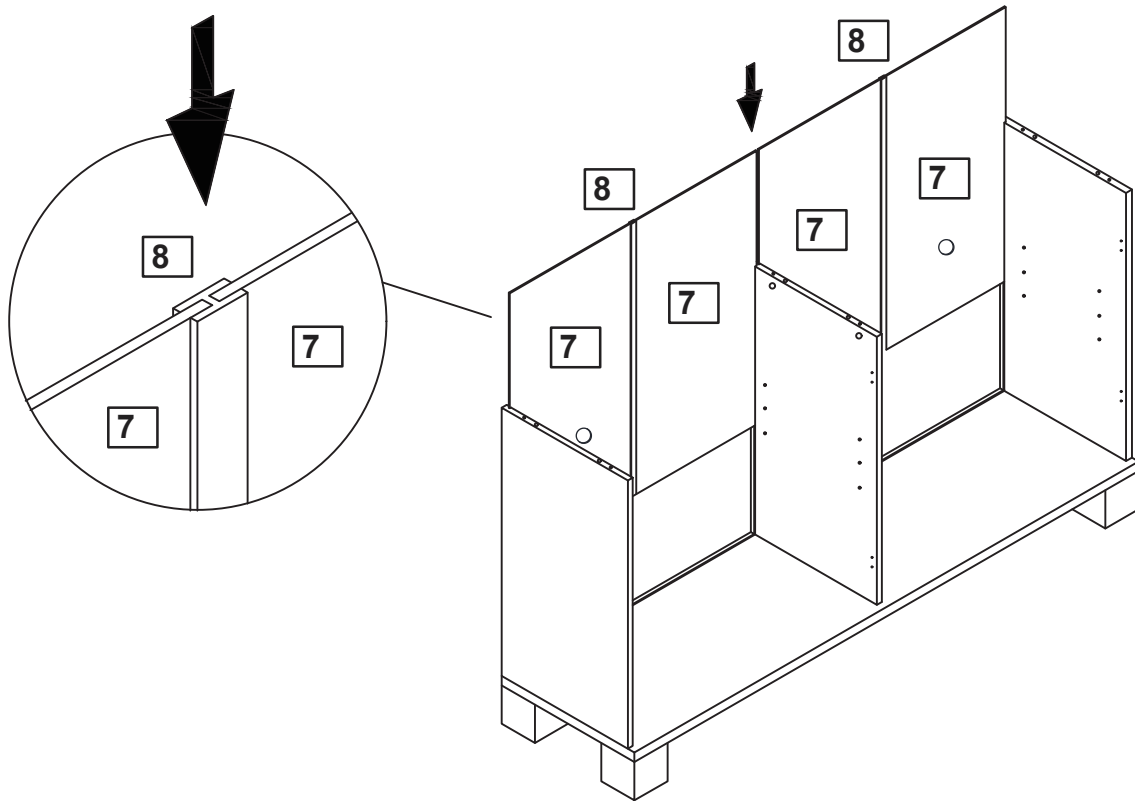

ASSEMBLY INSTRUCTION

Step 3

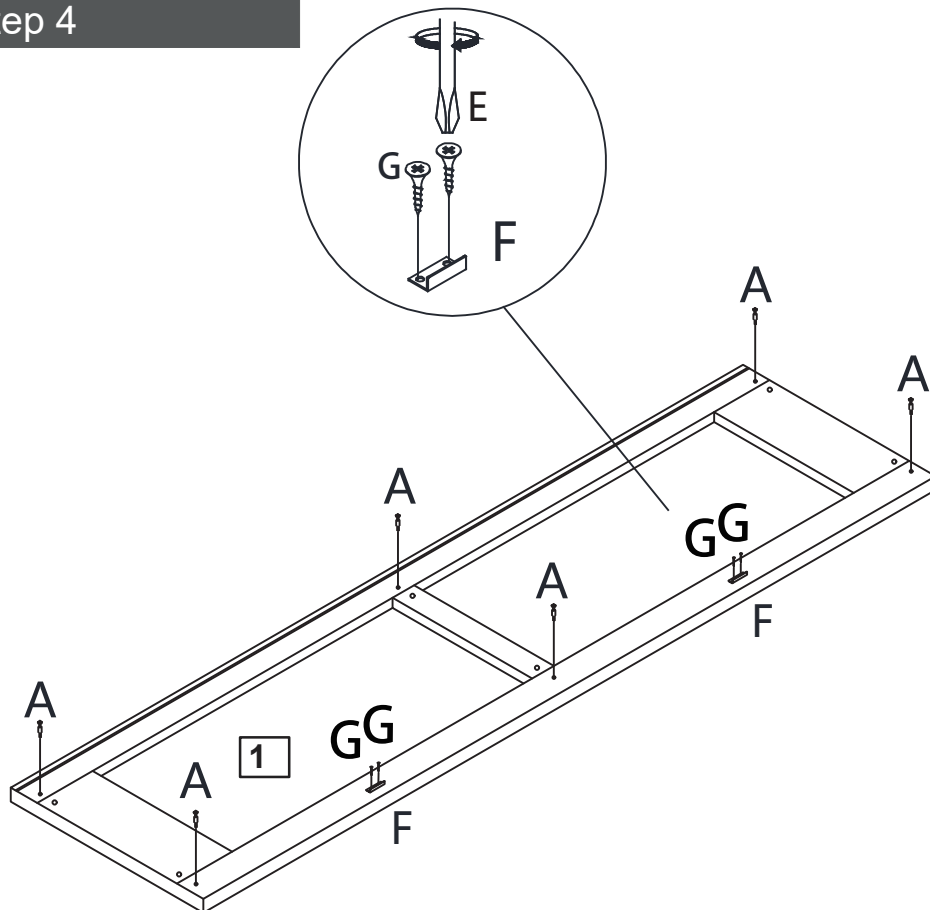

Step 4

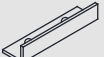

- A**  A x 6
- F**  F x 2
- G**  G x 4

ASSEMBLY INSTRUCTION

Step 5

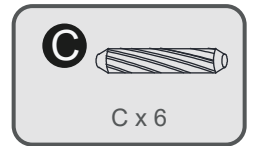
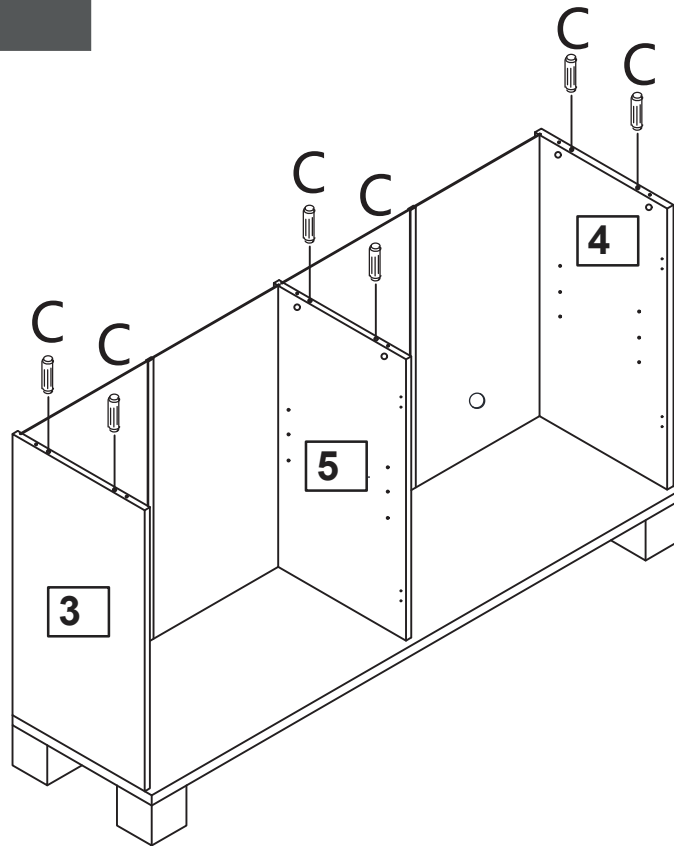

Step 6

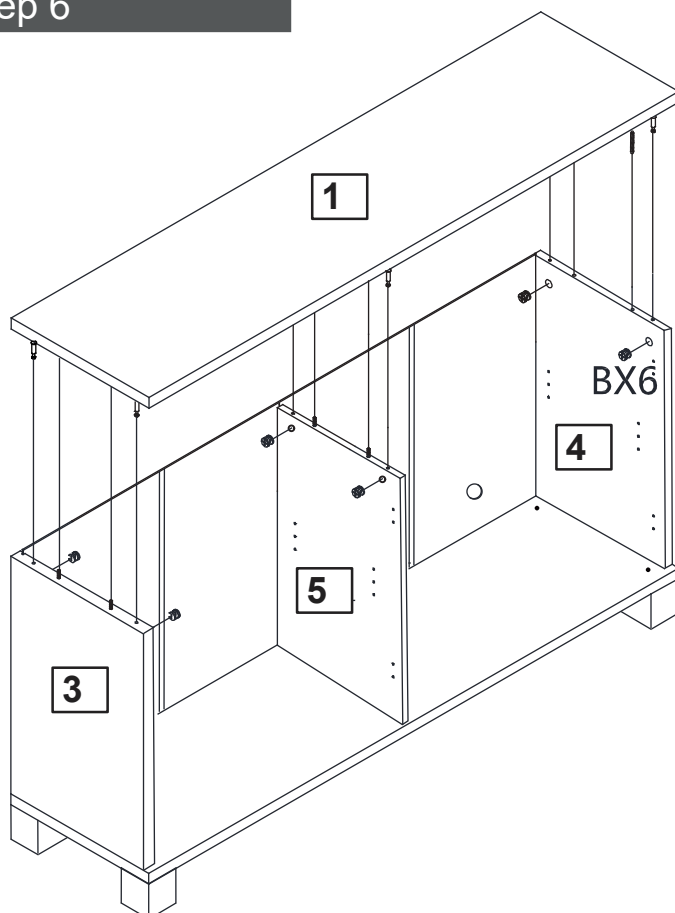

ASSEMBLY INSTRUCTION

Step 7

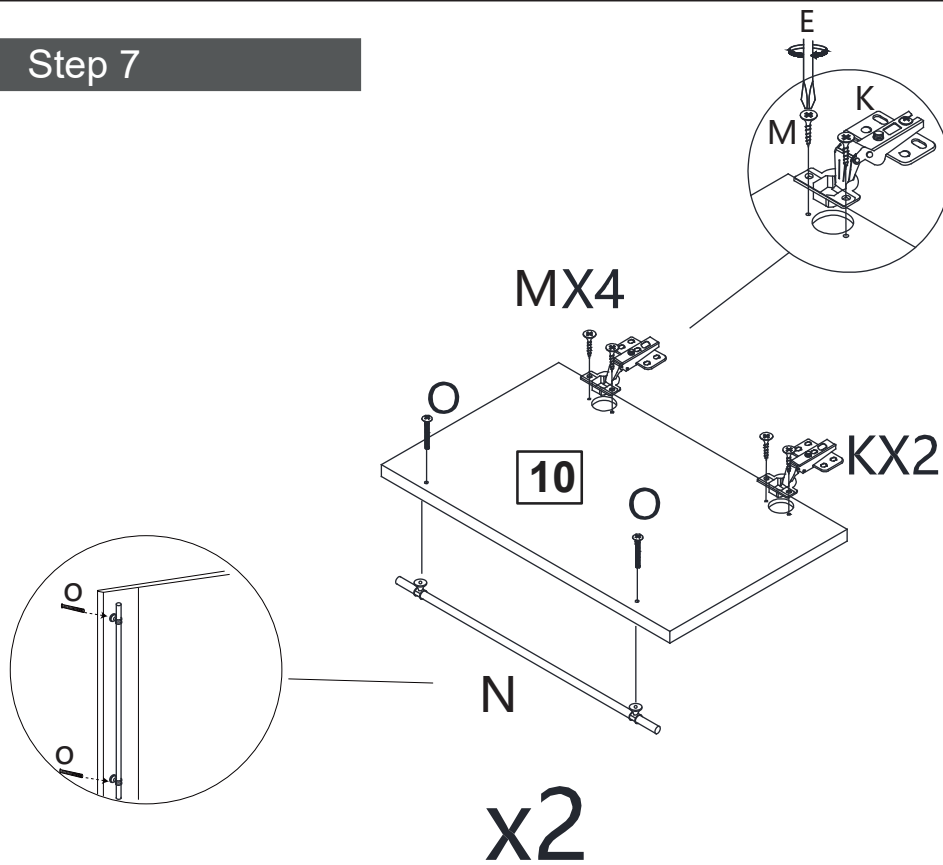

K x 4



M x 8



N x 2



O x 4

Step 8

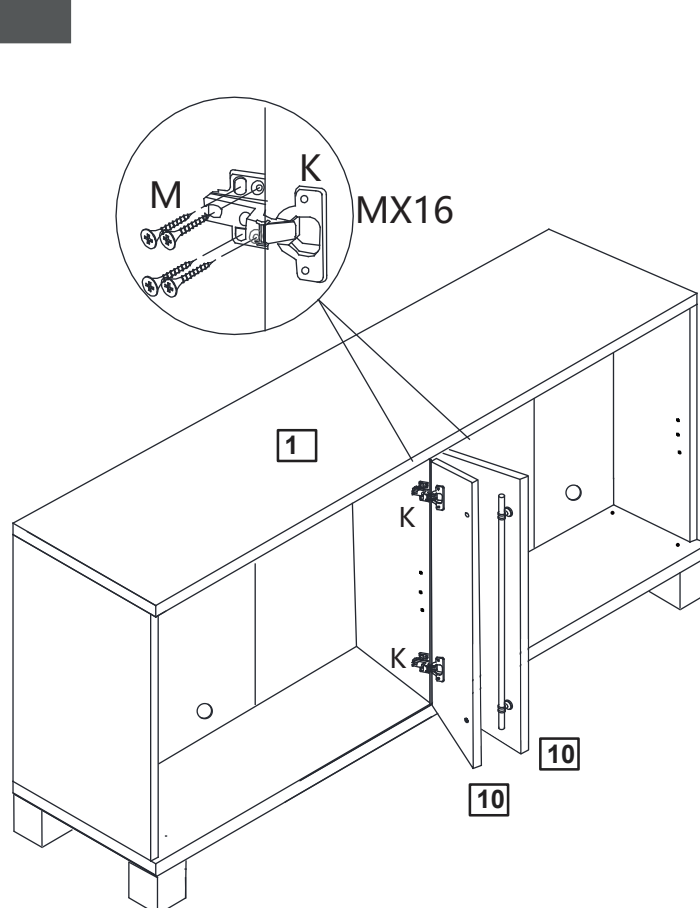

M x 16

ASSEMBLY INSTRUCTION

Step 9

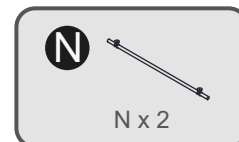
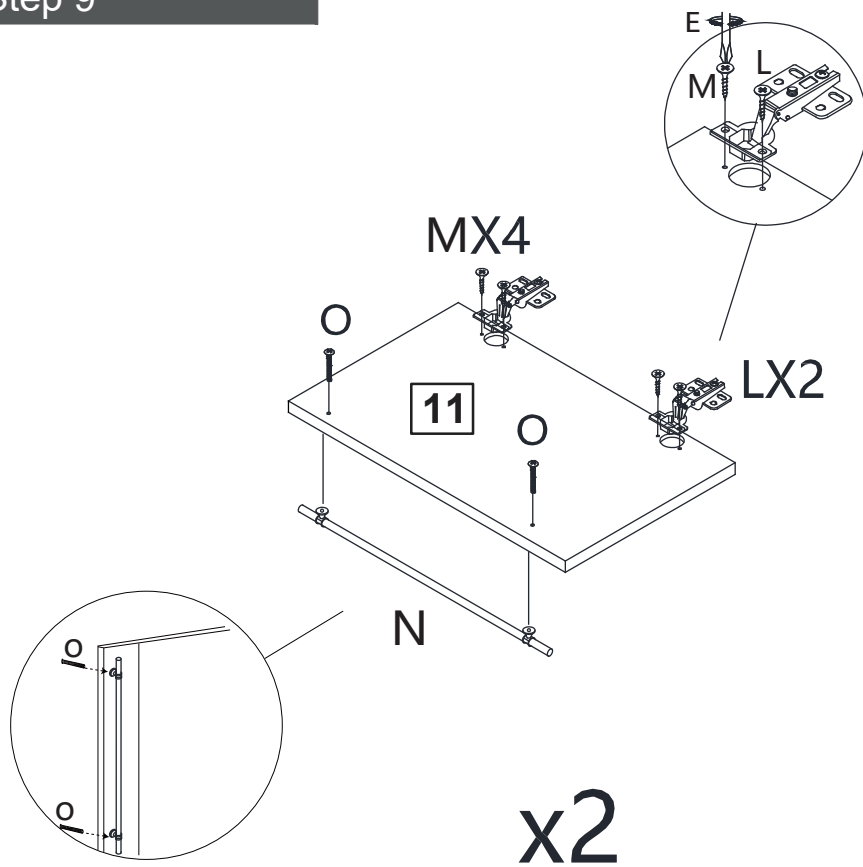

Step 10

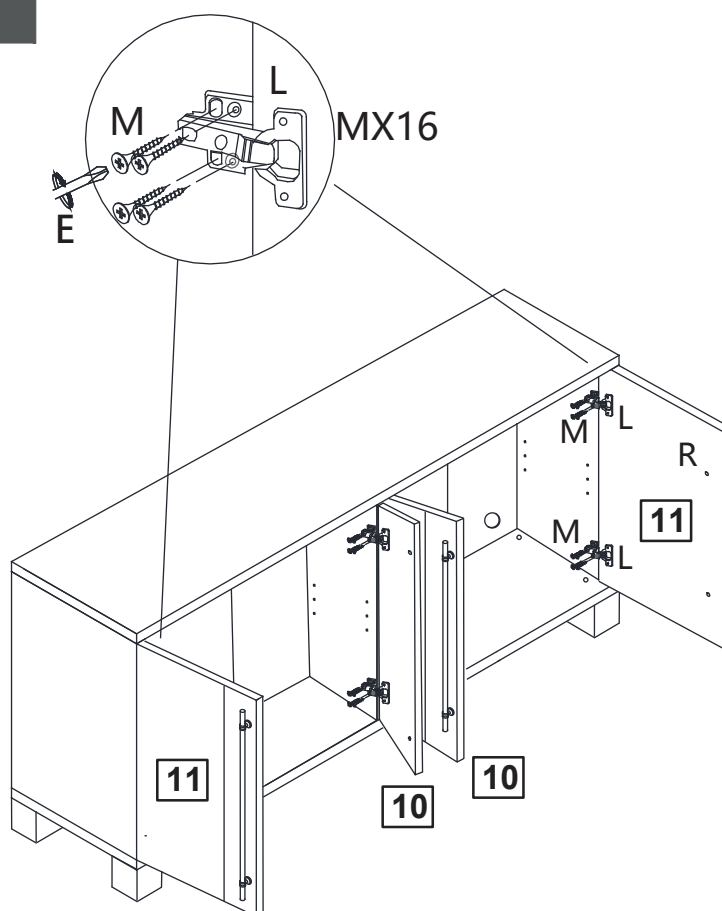

ASSEMBLY INSTRUCTION

Step 11

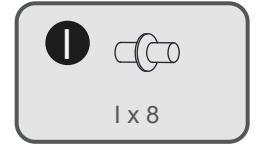
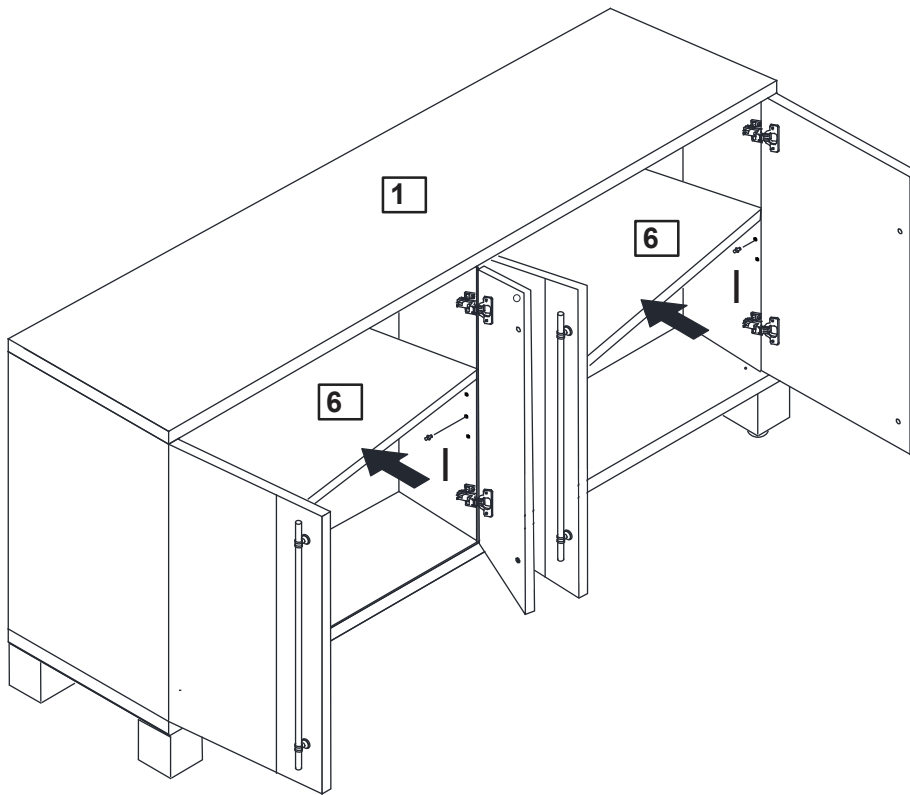

Step 12

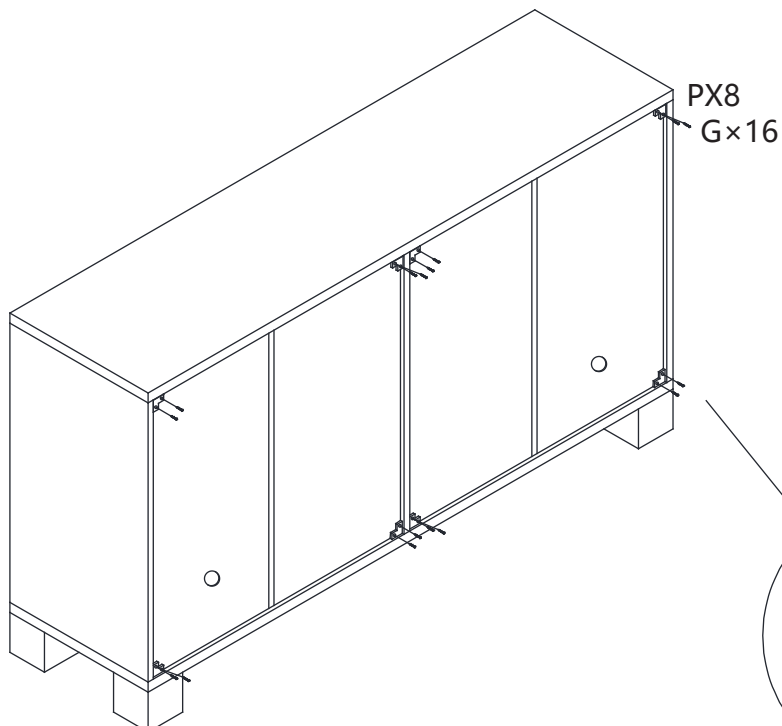

ASSEMBLY INSTRUCTION

Step 13

ANCHORING CABINET

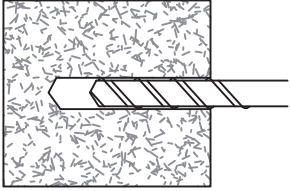

1. Use electric drill to drill a hole on the wall, the diameter and depth need to keep same with wall plug (Q1) provided (4*30mm)

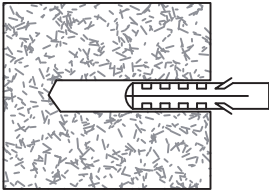

2. Use a rubber hammer to knock wall plug (Q1) into the wall

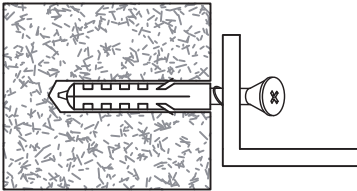

3. Insert the longer screw (Q3) through washer (Q5) & L bracket (Q2) provided as shown below. Attach screw & washer (Q4,Q5) onto cabinet's sides to hold it.

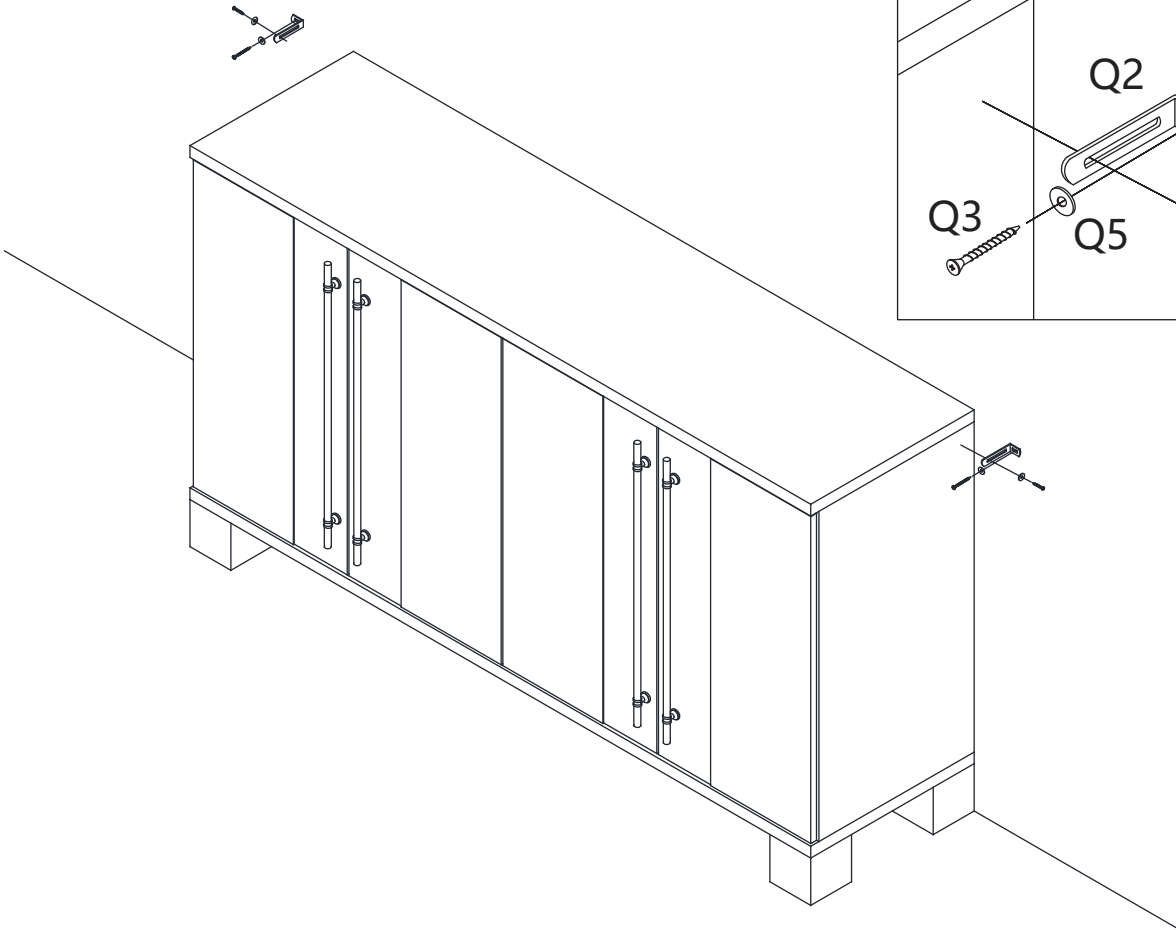
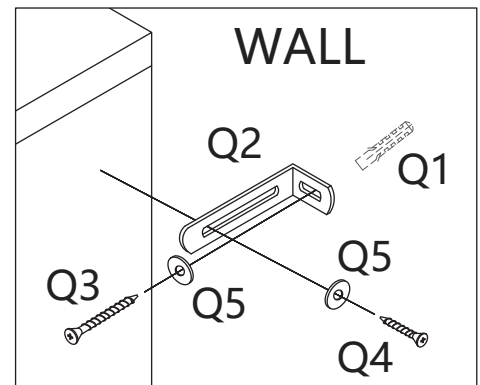

Assembly is complete.

ASSEMBLY INSTRUCTION

Assembly Steps(EN) / Montageschritte(DE)

HOW TO ADJUST THE HINGES TO ALIGN THE DOORS IF NEEDED.

STEP 1

Open the door.

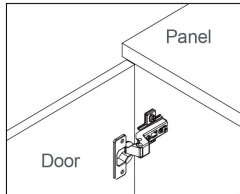

STEP 2

Adjust the door panels up or down

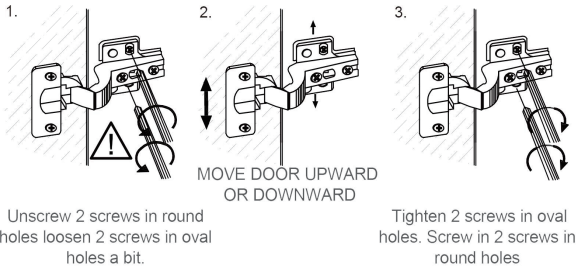

STEP 3

Adjust the flush between door panel and side panel

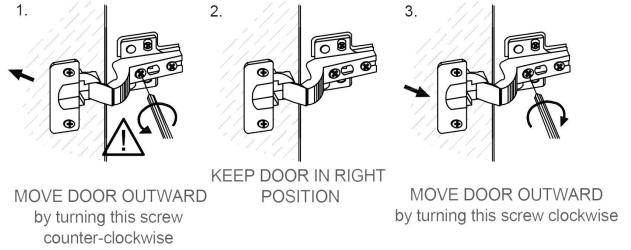

STEP 4

Adjust the Gap between door panel and side panel

