

Assembly Instruction / Montageanleitung

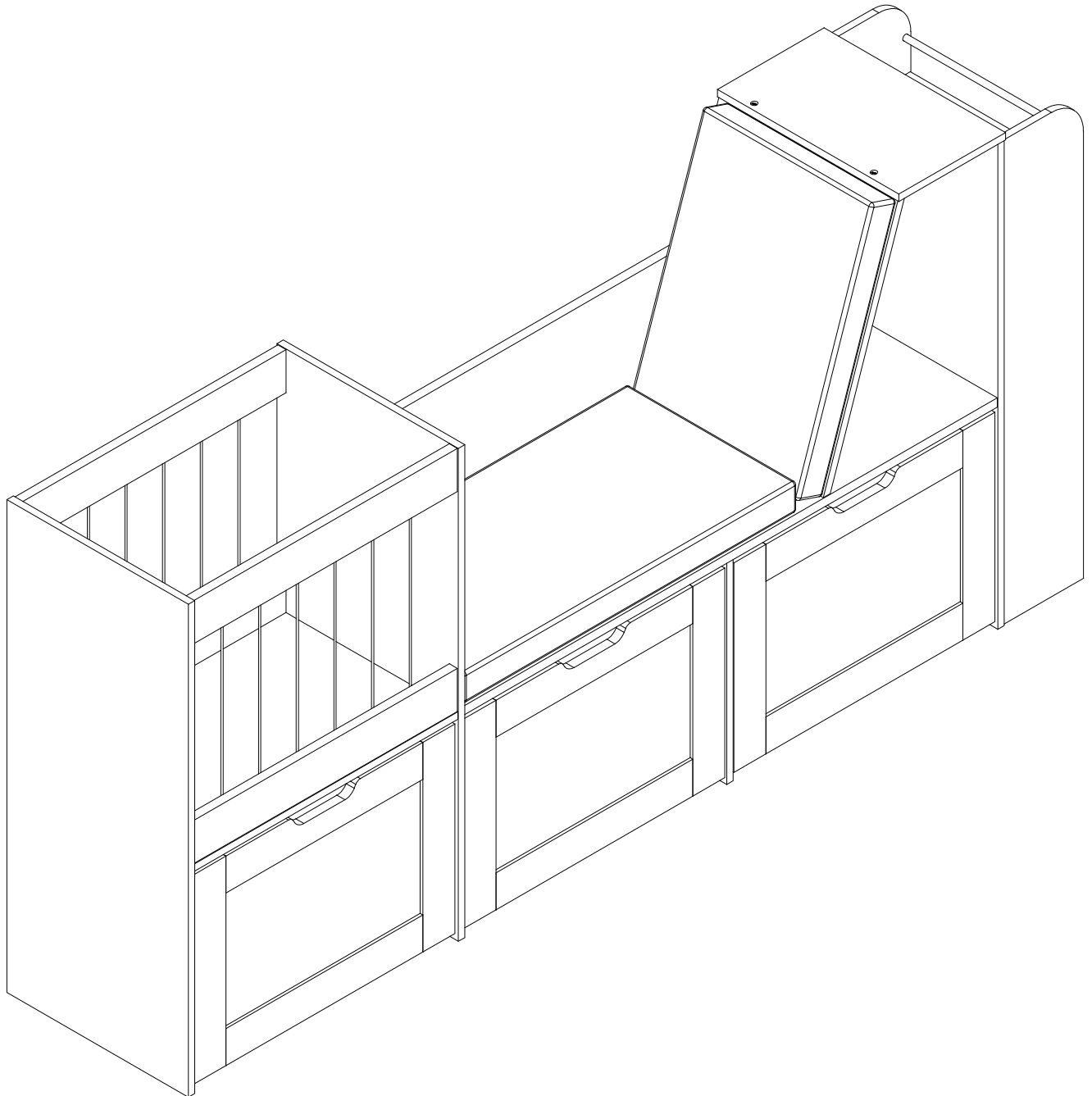

 **WARNING!!**

Assembled only by adults.

 **WARNUNG!**

Nur von Erwachsenen zusammenzubauen.

Thank you for choosing our product! We are committed to providing reliable support. Should you need any assistance, please reach out to us via the following channels:

1. After-Sales Support
2. Warranty Information: This product comes with a 12-month limited warranty from the date of purchase. If you wish to extend the warranty period, please send your order number to the after-sales support email.
3. Important Safety Reminder: For your child's safety, always complete assembly strictly according to the instruction manual. Use the product on a stable, level surface and never allow children to climb on it.



WARNING

Serious or fatal injury may occur from unexpected assembly or use.

1. During the assembly process, keep all parts away from babies or children.
2. Always securely fix this product to the wall. Make sure the wall area to be drilled is free from hidden electrical wires, water and gas pipes.
3. Use of tip-over restraints may only reduce, but not eliminate the risk of tip-over.
4. Unless specially designed to accommodate, do not set heavy objects on top of this product.
5. Place the heaviest items on the lowest shelf.
6. Never allow children to climb or bang on drawers, doors or shelves.
7. Assembled only by adults.



WARNING: CHOKING HAZARD

-Small parts.
Not for children under 3 years.

Merci de choisir our product! Nous nous engageons à fournir un support fiable. Si vous avez besoin d'aide, veuillez nous contacter via les canaux suivants:

1. De support après-vente
2. Informations sur la garantie: Ce produit bénéficie d'une garantie limitée de 12 mois à compter de la date d'achat. Si vous souhaitez prolonger la durée de garantie, veuillez envoyer votre numéro de commande à l'e-mail de support après-vente.
3. Rappel de sécurité important: Pour la sécurité de votre enfant, effectuez toujours l'assemblage strictement conformément au manuel d'instructions. Utilisez le produit sur une surface stable et plane, et ne laissez jamais les enfants grimper dessus.



AVERTISSEMENT

Un montage ou une utilisation incorrects peuvent entraîner des blessures graves ou mortelles.

1. Pendant le processus de montage, gardez toutes les pièces hors de portée des bébés et des enfants.
2. Fixez toujours solidement ce produit au mur. Assurez-vous que la zone du mur à percer est exempte de fils électriques, de conduites d'eau ou de gaz dissimulés.
3. L'utilisation de dispositifs anti-basculement ne peut que réduire, mais pas éliminer, le risque de basculement du produit.
4. Sauf disposition spéciale prévue à cet effet, ne placez pas d'objets lourds sur le dessus de ce produit.
5. Placez les objets les plus lourds sur l'étagère inférieure.
6. Ne laissez jamais les enfants grimper sur les tiroirs, les portes ou les étagères, ni les frapper.
7. À monter exclusivement par un adulte.



AVERTISSEMENT : RISQUE D'ÉTOUFFEMENT

-Ne convient pas aux enfants de moins de 3 ans.

Vielen Dank, dass Sie sich für our product entschieden haben! Unser Kundenservice bietet Ihnen zuverlässige Unterstützung. Sollten Sie Hilfe benötigen, kontaktieren Sie uns bitte über die folgenden Kanäle:

1. Für After-Sales-Support
2. Garantieinformationen: Dieses Produkt verfügt über eine 12-monatige begrenzte Garantie ab dem Kaufdatum. Wenn Sie die Garantiezeit verlängern möchten, senden Sie bitte Ihre Bestellnummer an die After-Sales-Support-E-Mail.
3. Wichtiger Sicherheitshinweis: Für die Sicherheit Ihres Kindes führen Sie die Montage stets streng nach der Montageanleitung durch. Verwenden Sie das Produkt nur auf einer stabilen, ebenen Fläche und lassen Sie Kinder niemals darauf klettern.



WARNUNG

Durch unbeabsichtigte Montage oder Nutzung können schwere oder tödliche Verletzungen auftreten.

1. Halten Sie während des Montagevorgangs alle Teile von Babys oder Kindern fern.
2. Befestigen Sie dieses Produkt immer sicher an der Wand. Stellen Sie sicher, dass der zu bohrende Wandbereich frei von verborgenen elektrischen Kabeln, Wasser- und Gasleitungen ist.
3. Die Verwendung von Kippsicherungsrichtungen kann das Kipprisiko nur verringern, aber nicht beseitigen.
4. Setzen Sie keine schweren Gegenstände auf das Produkt, es sei denn, es ist speziell dafür ausgelegt.
5. Platzieren Sie die schwersten Gegenstände auf dem untersten Fach.
6. Lassen Sie Kinder niemals auf Schubläden, Türen oder Fächern klettern oder dagegen schlagen.
7. Nur von Erwachsenen zusammenzubauen.



WARNUNG: ERSTICKUNGSGEFAHR

-Kleine Teile.

Nicht für Kinder unter 3 Jahren geeignet.

Grazie per aver scelto our product! Offriamo un supporto affidabile. Se avete bisogno di assistenza, contattateci tramite i seguenti canali:

1. Di supporto post-vendita
2. Informazioni sulla garanzia: Questo prodotto è coperto da una garanzia limitata di 12 mesi a partire dalla data di acquisto. Se desiderate prorogare il periodo di garanzia, inviate il vostro numero d'ordine all'e-mail di supporto post-vendita.
3. Promemoria di sicurezza importante: Per la sicurezza del vostro bambino, eseguite sempre l'assemblaggio rigorosamente secondo il manuale di istruzioni. Utilizzate il prodotto su una superficie stabile e piana e non lasciate mai i bambini arrampicarsi su di esso.



AVVERTENZA

L'assemblaggio o l'utilizzo non corretti possono causare lesioni gravi o mortali.

1. Durante il processo di assemblaggio, tenere tutte le parti lontane da neonati e bambini.
2. Fissare sempre saldamente questo prodotto al muro. Assicurarsi che l'area del muro da perforare sia priva di cavi elettrici nascosti, tubazioni d'acqua e gas.
3. L'uso di dispositivi anti-ribaltamento può solo ridurre, ma non eliminare, il rischio di ribaltamento.
4. Non posizionare oggetti pesanti sopra questo prodotto, a meno che non sia stato specificamente progettato per tale scopo.
5. Posizionare gli oggetti più pesanti sul ripiano inferiore.
6. Non permettere mai ai bambini di arrampicarsi o di colpire i cassetti, le porte o i ripiani.
7. Assemblaggio esclusivamente da adulti.



AVVERTENZA: RISCHIO DI SOFFOCAMENTO

-Piccole parti.

Non adatto a bambini di età inferiore ai 3 anni.

¡Gracias por elegir our product! Ofrecemos un soporte confiable. Si necesitas ayuda, ponte en contacto con nosotros a través de los siguientes canales:

1. Correo electrónico de soporte
2. Información de garantía: Este producto cuenta con una garantía limitada de 12 meses a partir de la fecha de compra. Si deseas extender el período de garantía, envía tu número de pedido al correo electrónico de soporte postventa.
3. Recordatorio de seguridad importante: Para la seguridad de tu hijo, realiza siempre el montaje estrictamente de acuerdo con el manual de instrucciones. Usa el producto en una superficie estable y nivelada y nunca permitas que los niños se suban a él.



ADVERTENCIA

El montaje o uso incorrecto puede causar lesiones graves o mortales.

1. Durante el proceso de ensamblaje, mantenga todas las piezas alejadas de bebés y niños.
2. Fije siempre este producto firmemente a la pared. Asegúrese de que la zona de la pared a perforar esté libre de cables eléctricos ocultos, tuberías de agua y gas.
3. El uso de dispositivos anti-vuelco solo puede reducir, pero no eliminar, el riesgo de vuelco.
4. No coloque objetos pesados encima de este producto, a menos que esté especialmente diseñado para ello.
5. Coloque los objetos más pesados en el estante inferior.
6. Nunca permita que los niños escalen o golpeen los cajones, puertas o estantes.
7. Ensamblaje exclusivamente por adultos.









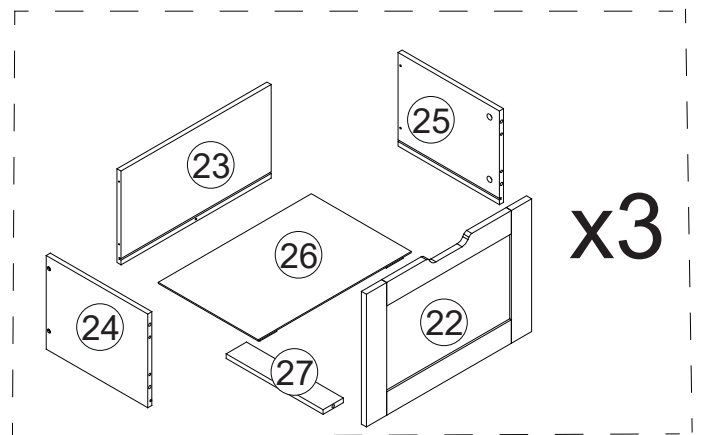
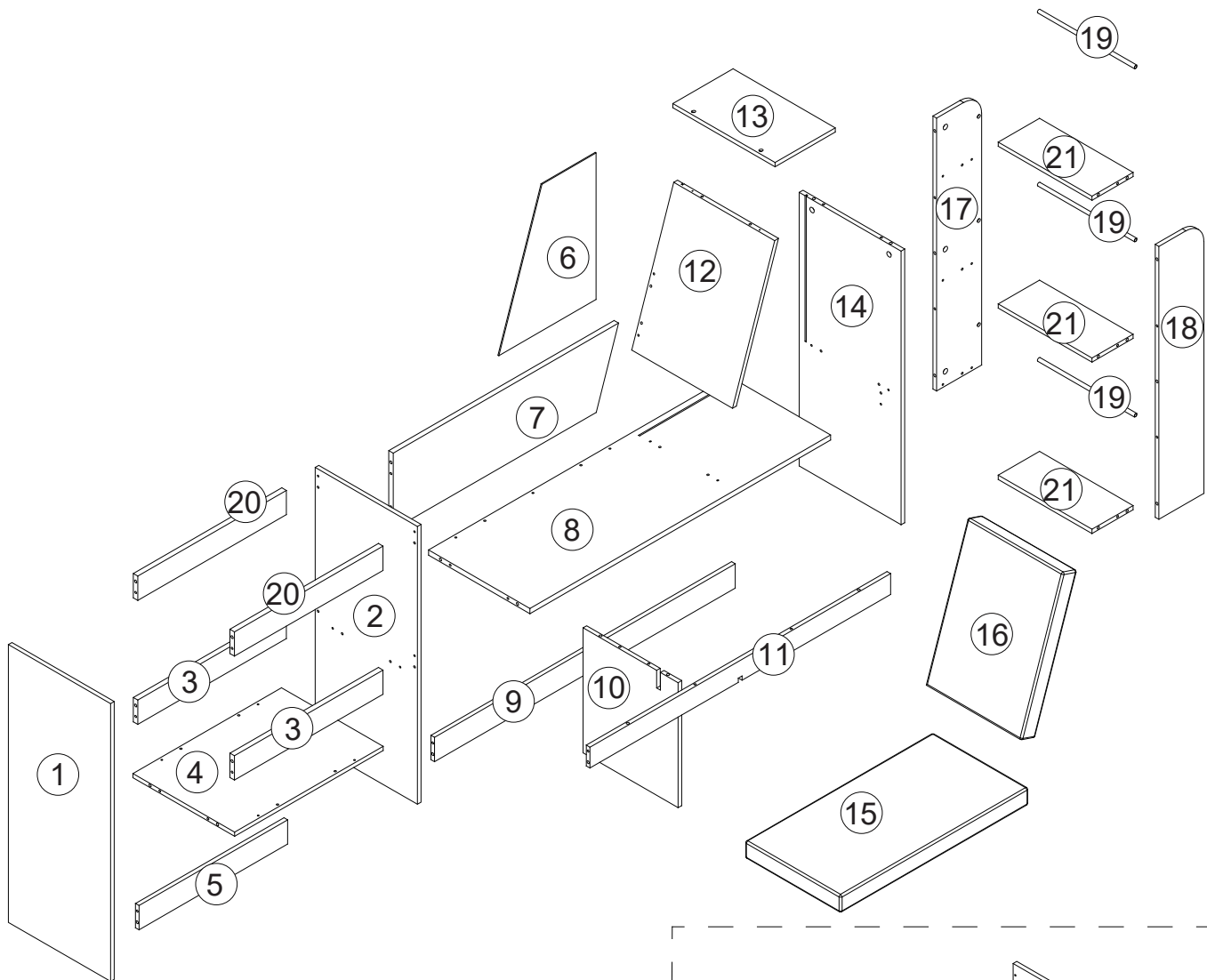

ADVERTENCIA: RIESGO DE ASFIXIA

-Piezas pequeñas.

No apto para niños menores de 3 años.

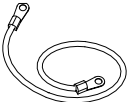

A	x63+2	B	x63+2	C	x64+2	D	x74+2	E	x12	F	x31+2	G	x12+2	H	x2	J	x2
																	
M6x35mm		Ø15x9mm		Ø6x30mm		Ø4x12mm				Ø4x35mm							

1

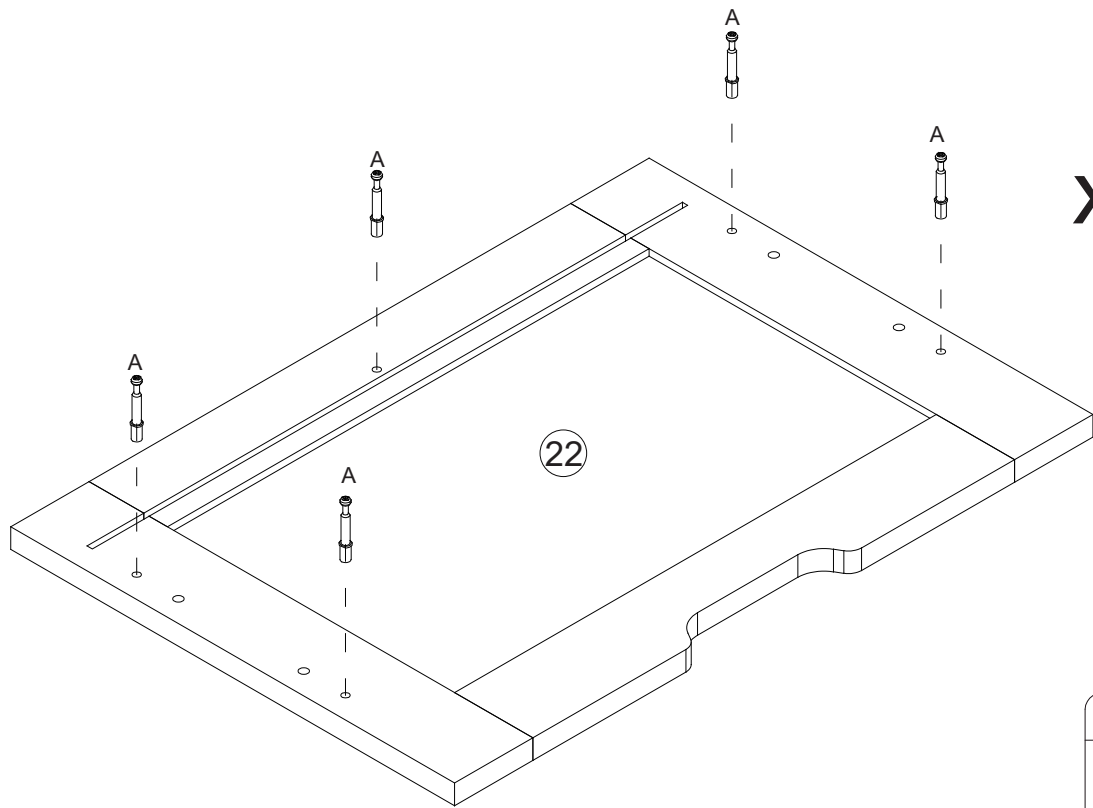
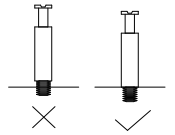

x3

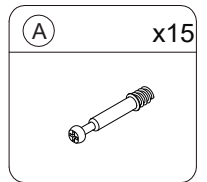

2

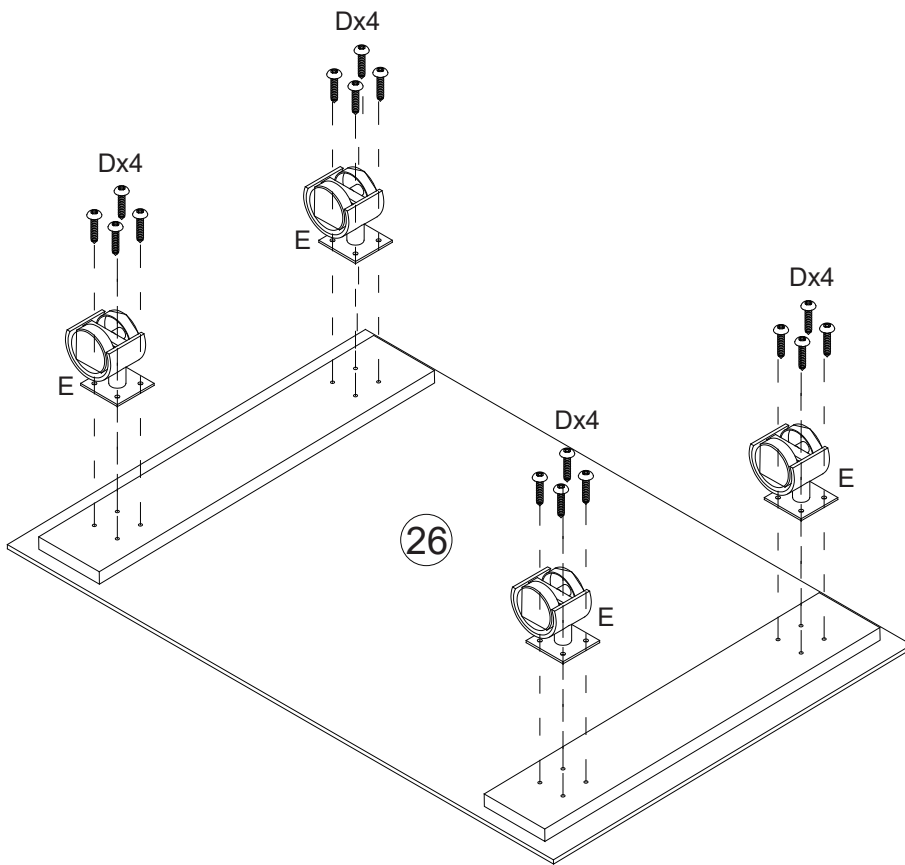

x3

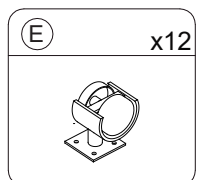
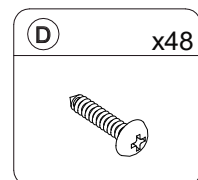

3

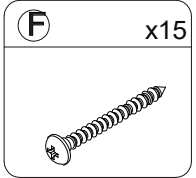
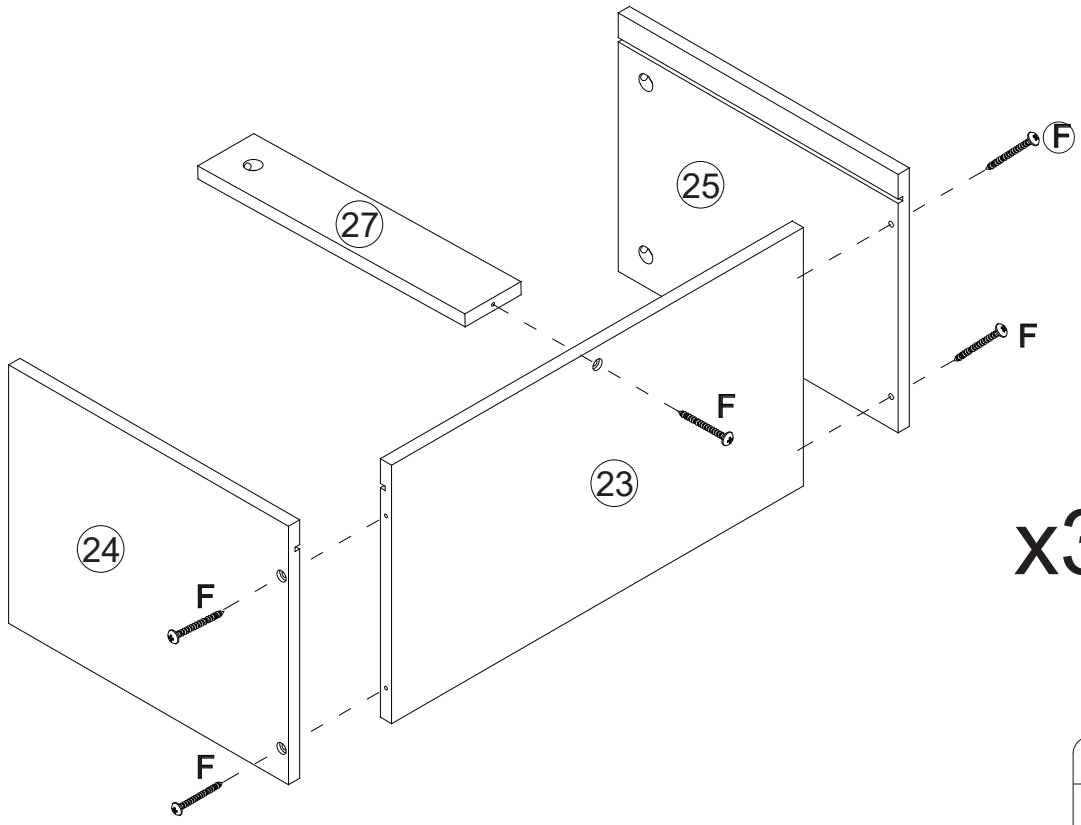

4

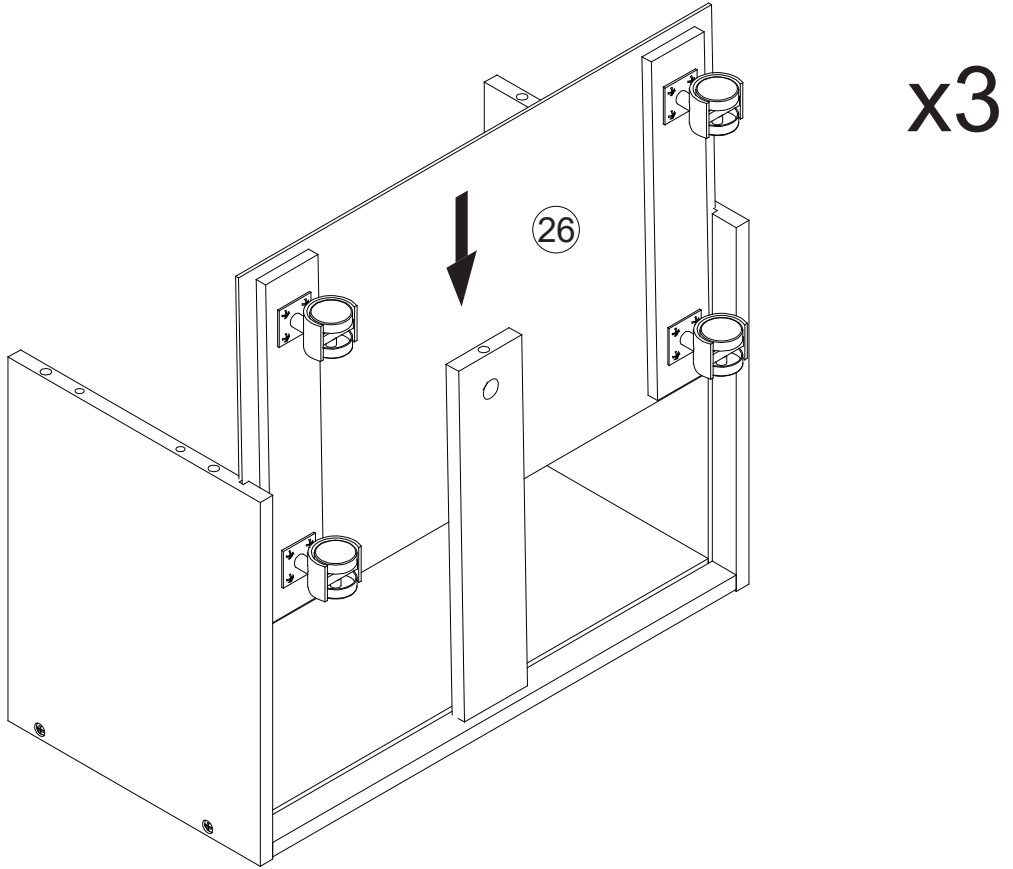

5

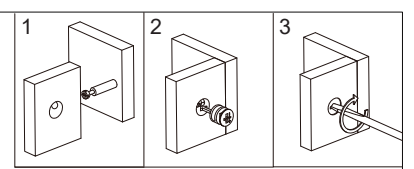
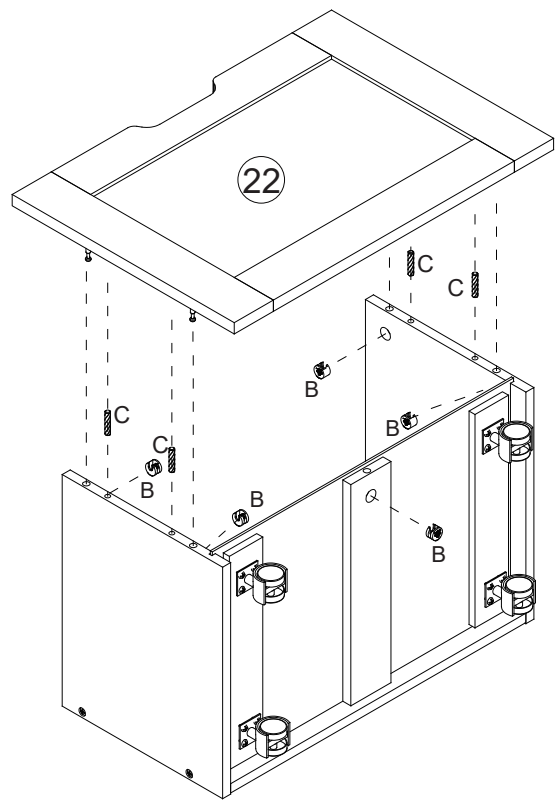

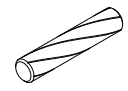

Cam Lock Fastening System

x3

(B)	x15	(C)	x12
			

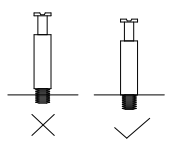
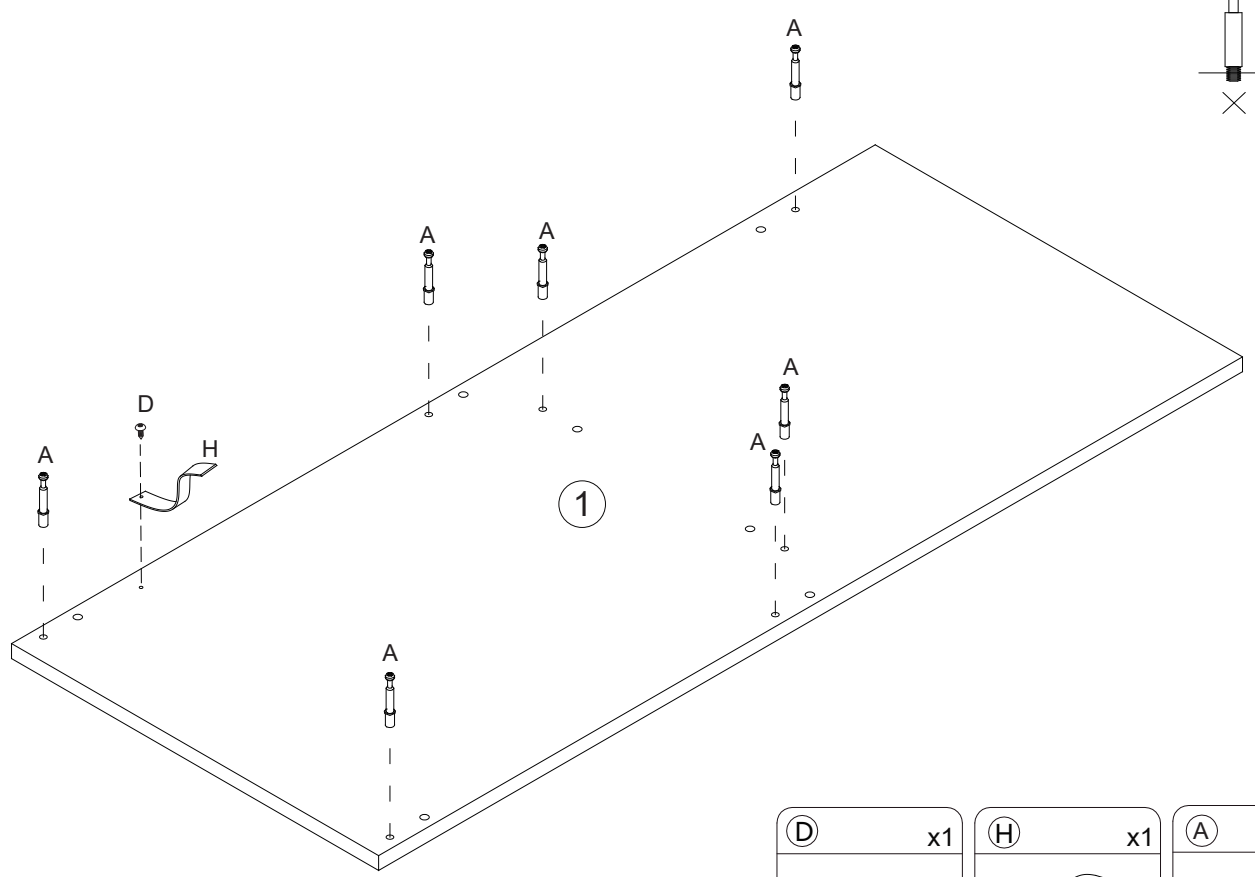
6

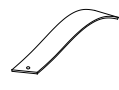
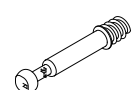

(D)	x1	(H)	x1	(A)	x7
					

7

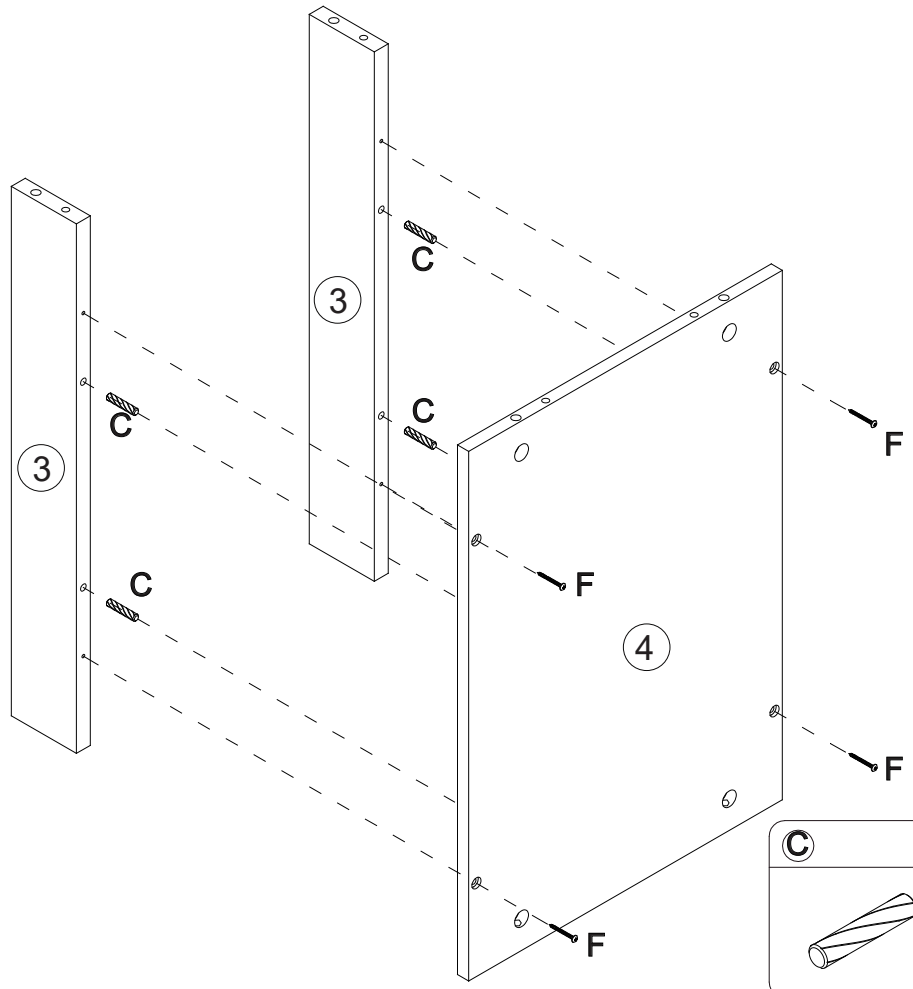

C	x4	F	x4

8

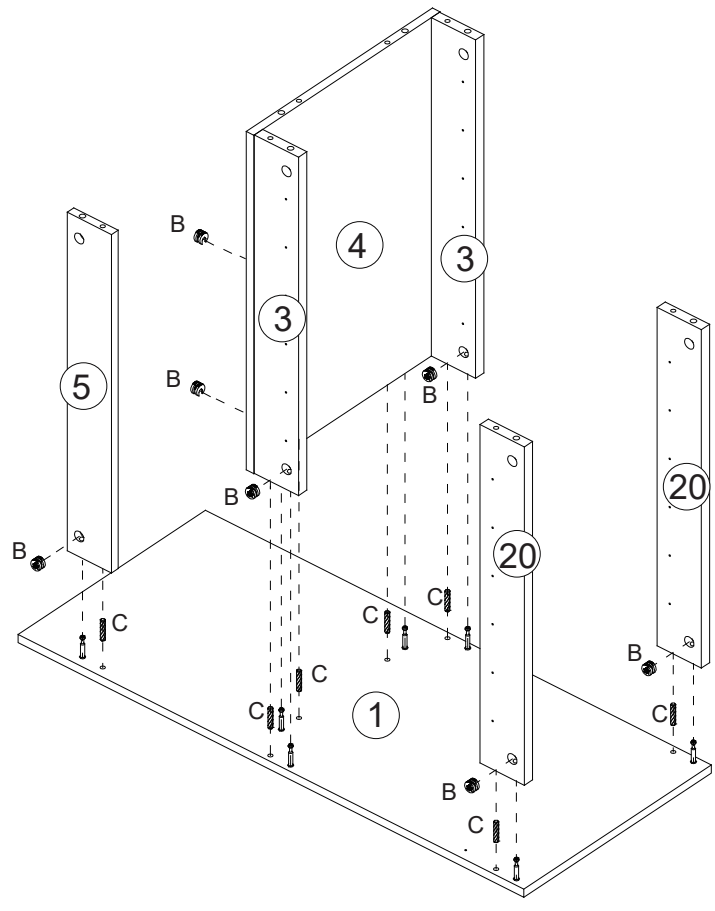

1 2 3 **Cam Lock Fastening System**

B	x7	C	x7

9

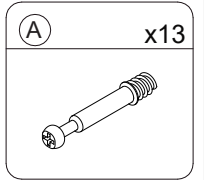
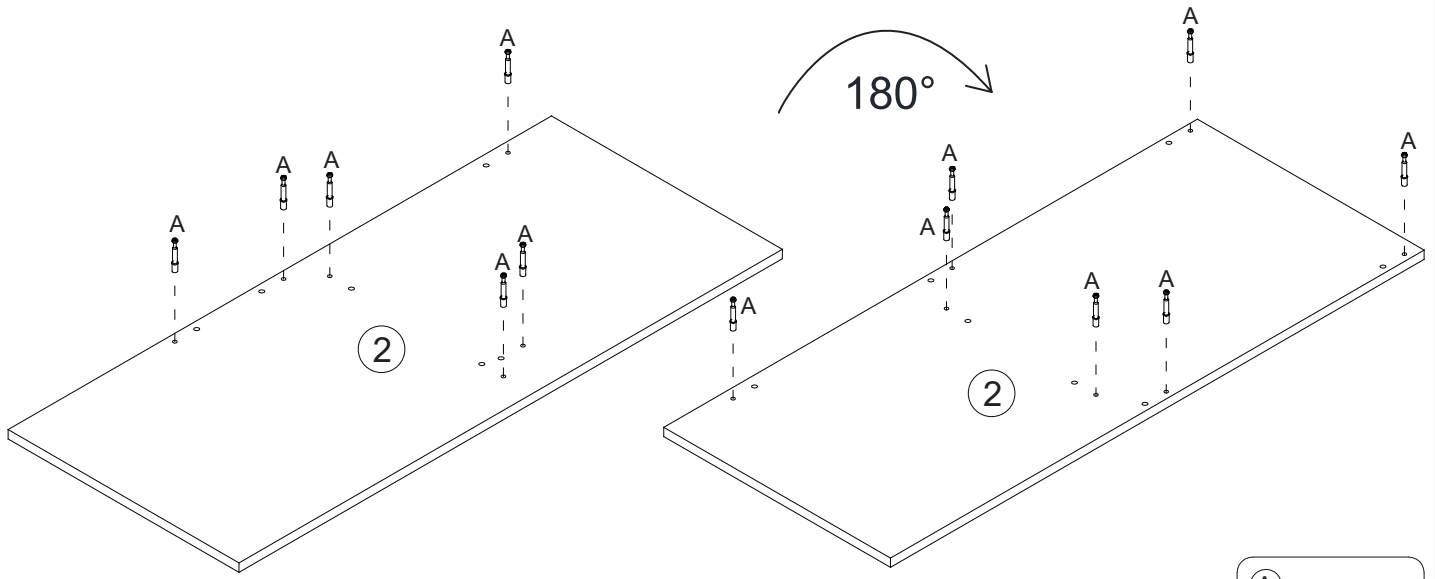
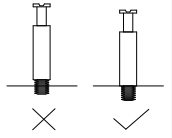

10

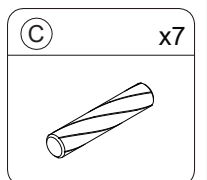
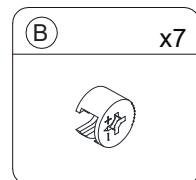
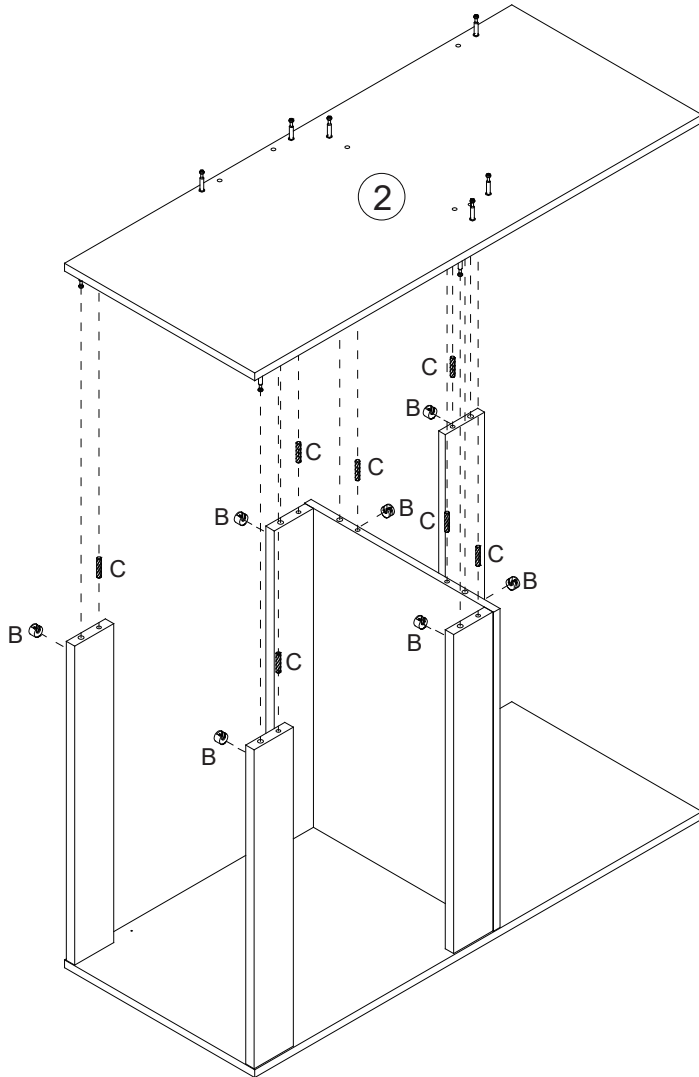
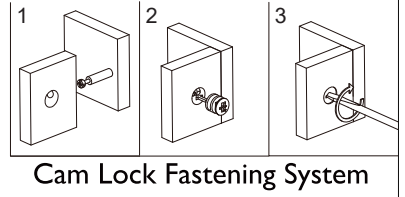

11

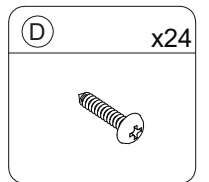
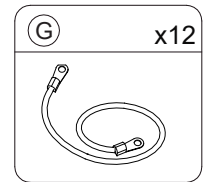
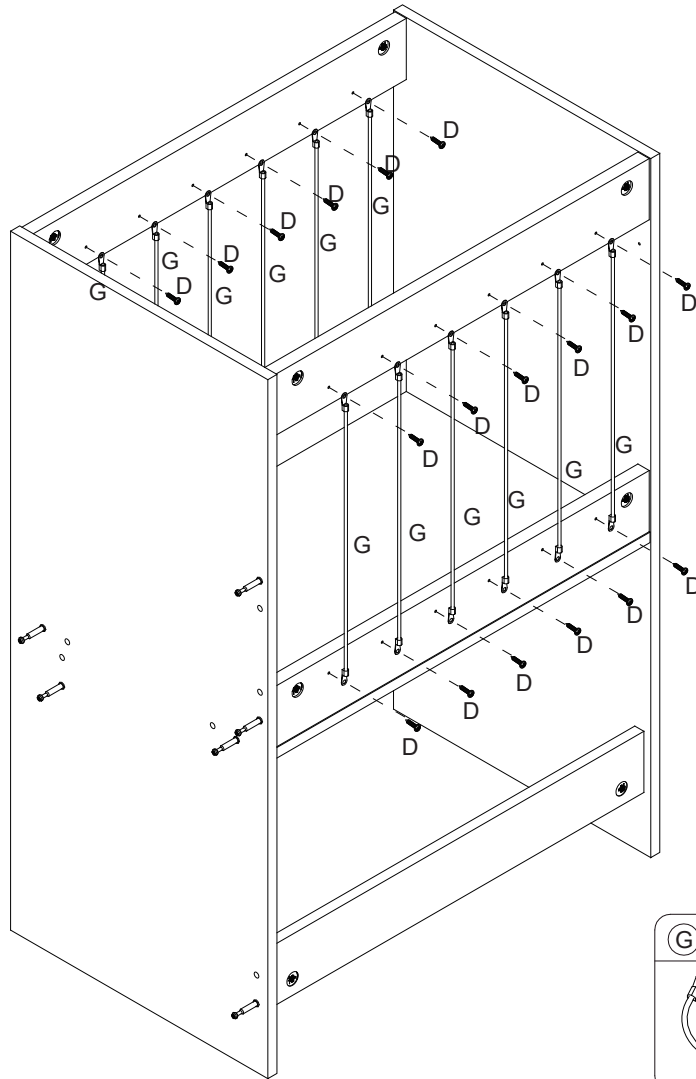

12

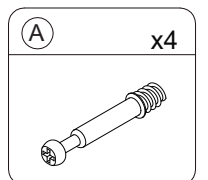
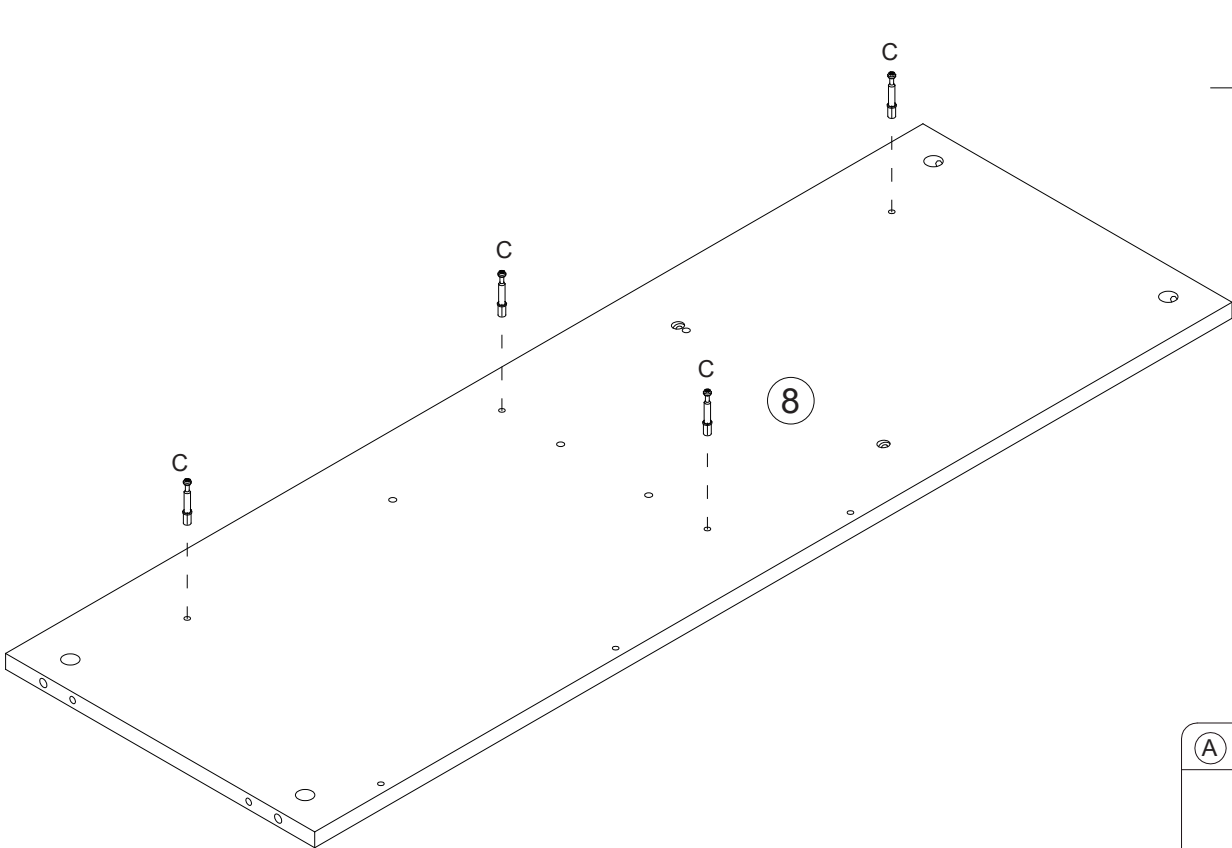

13

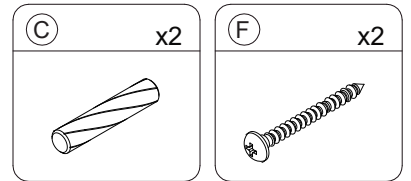
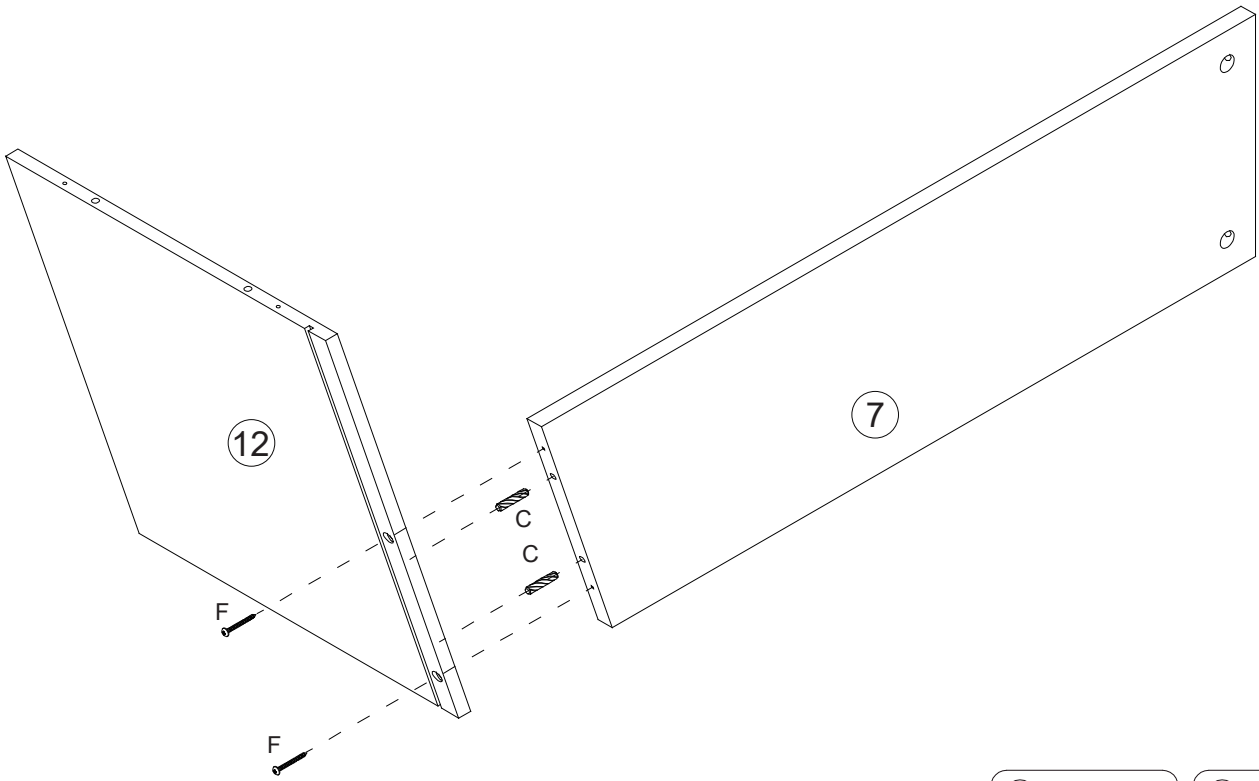

14

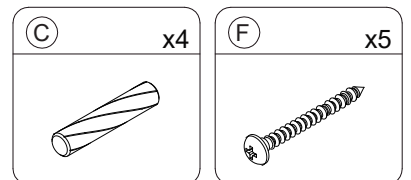
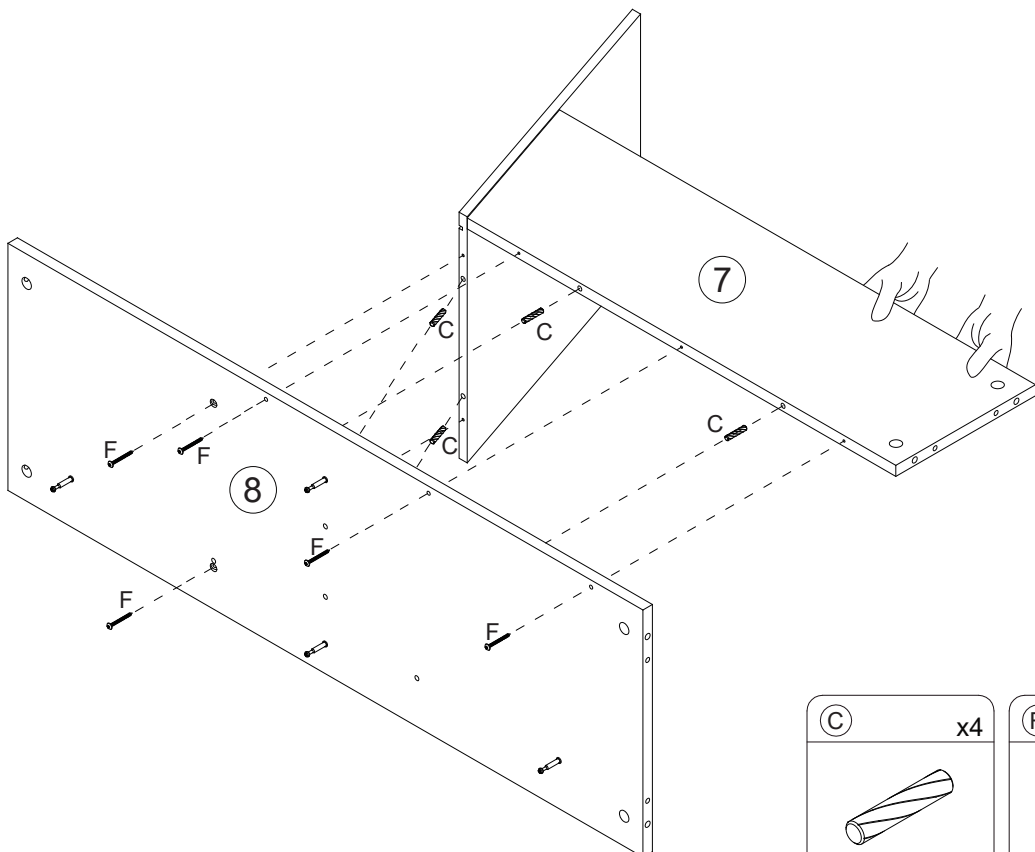

15

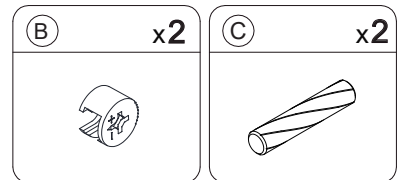
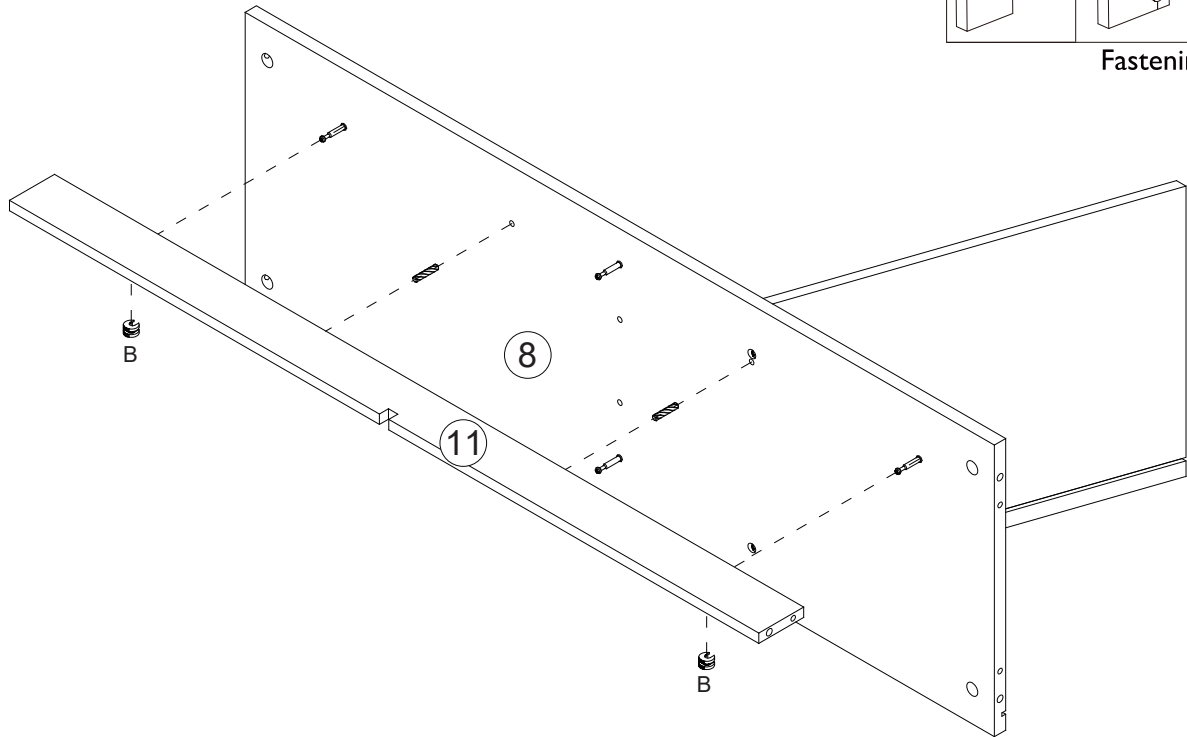
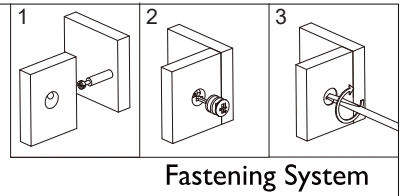

16

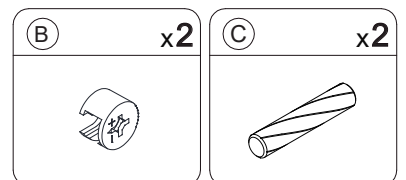
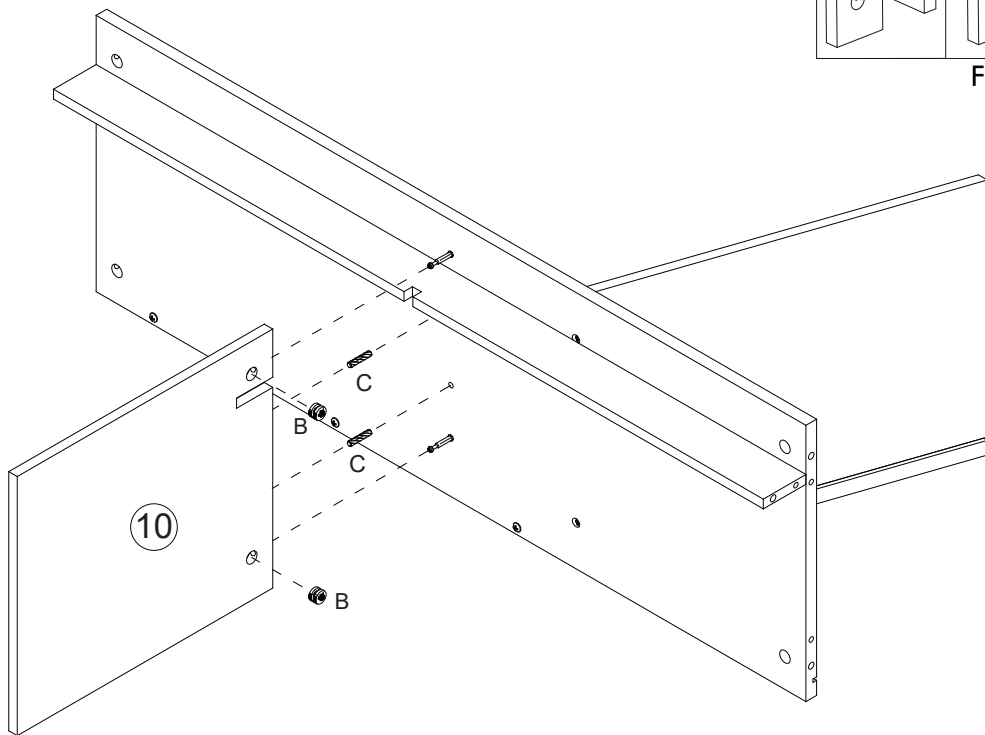
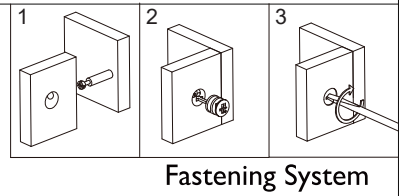

17

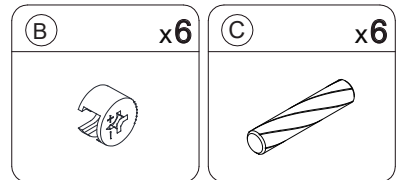
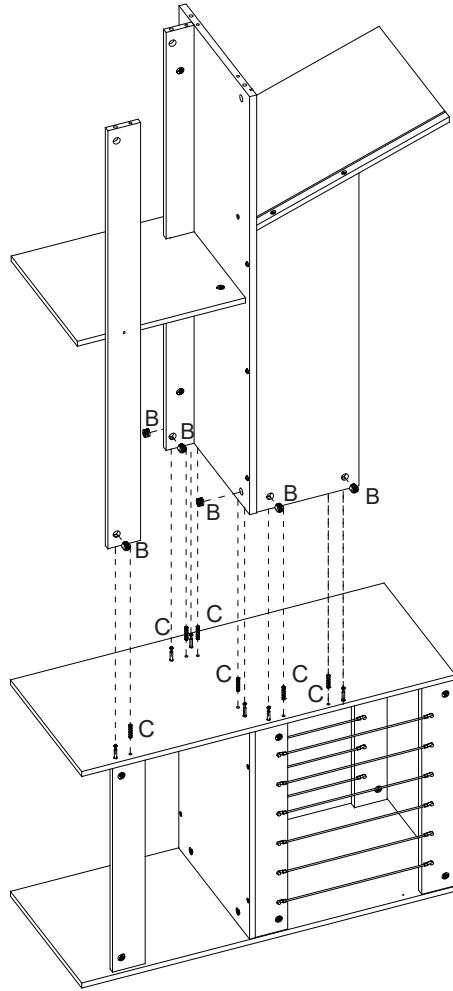
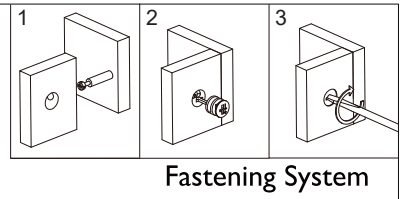

18

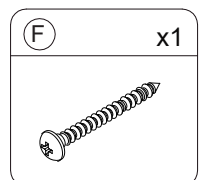
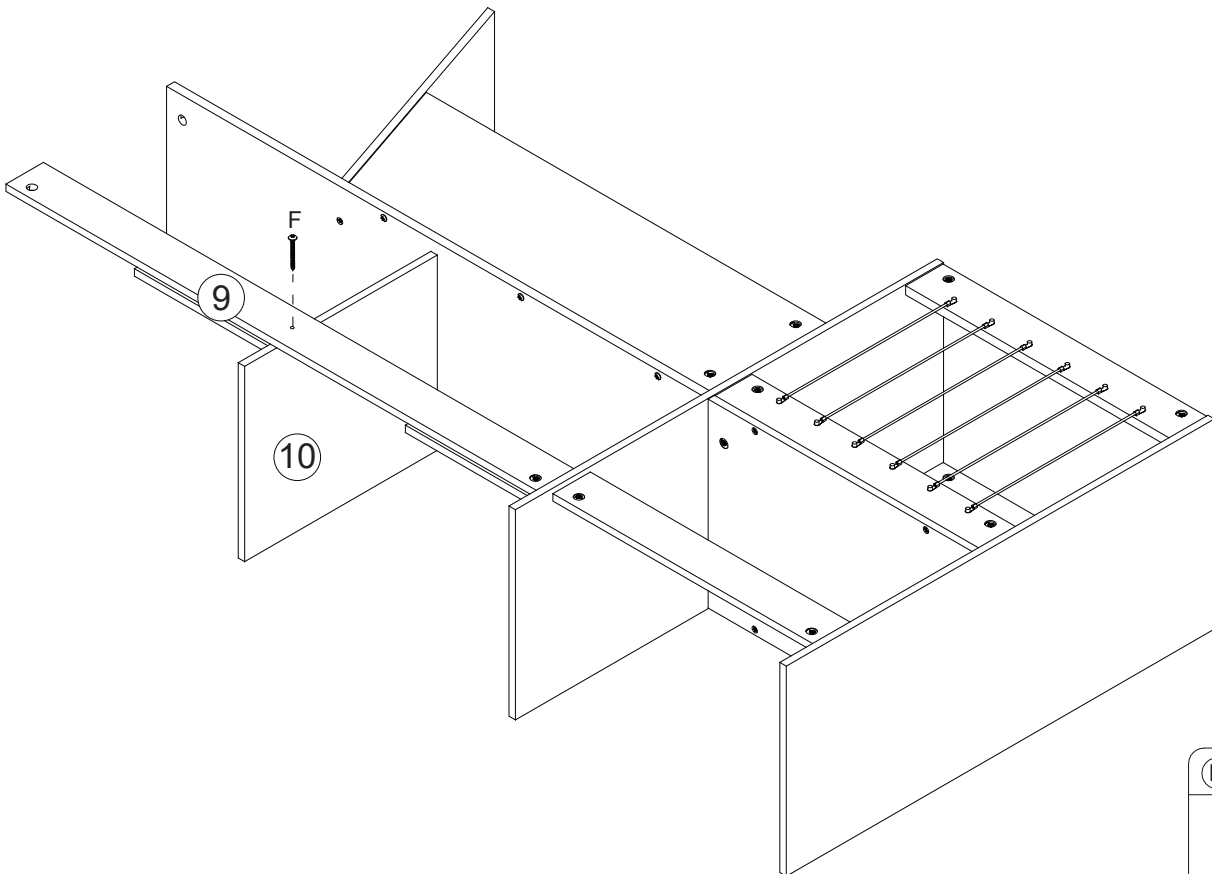

19

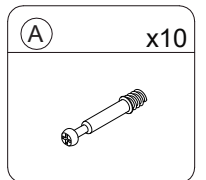
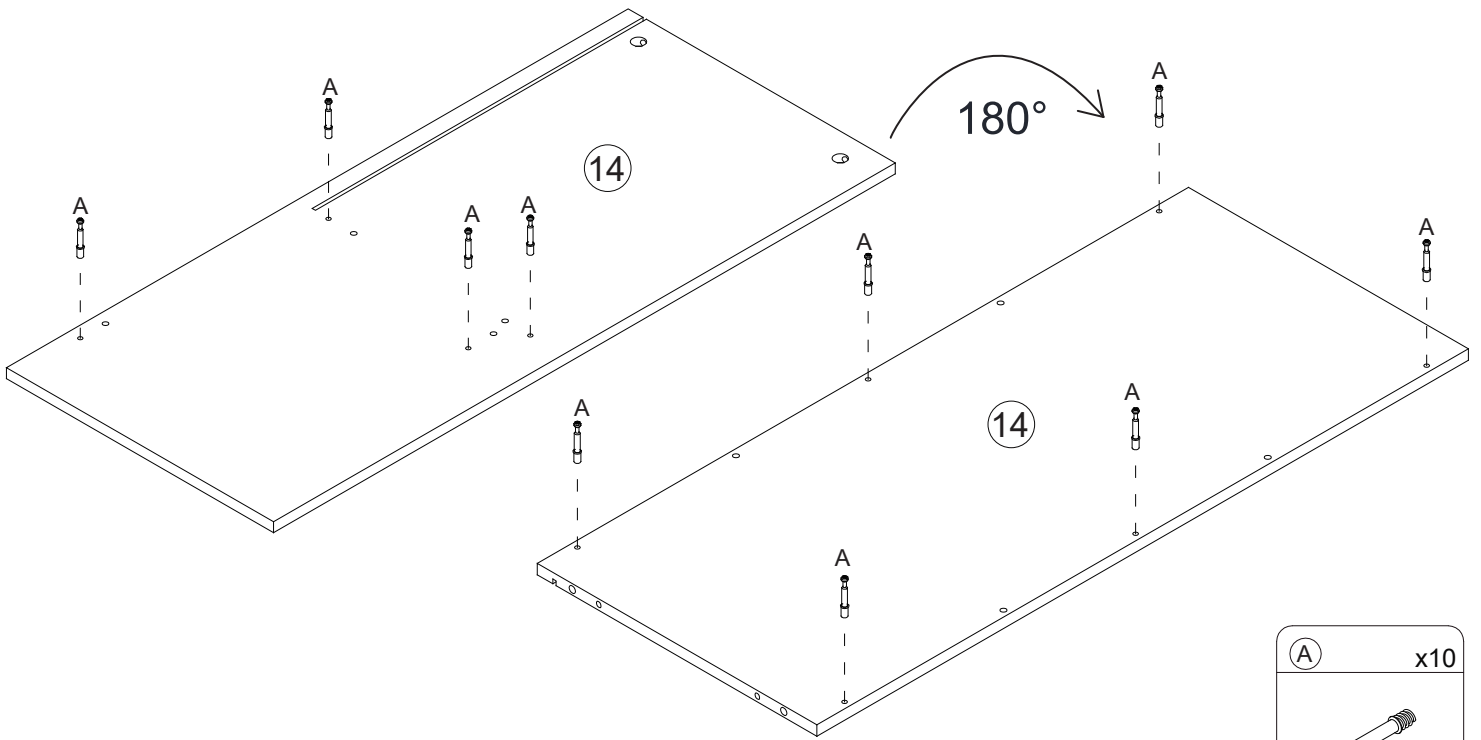
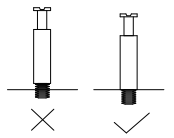

20

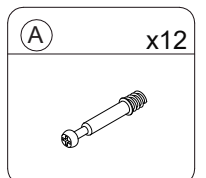
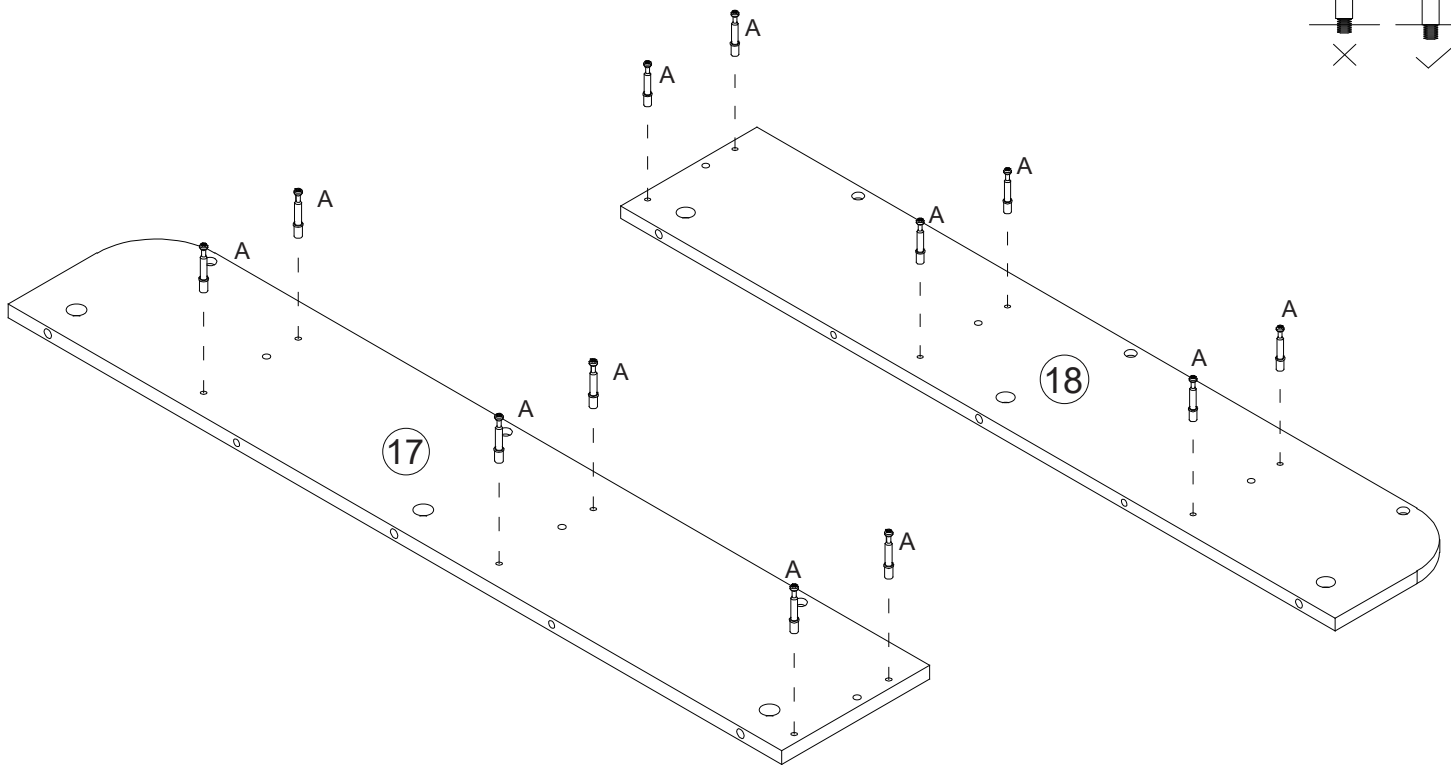
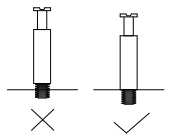

21

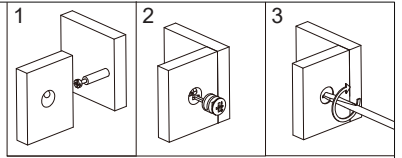
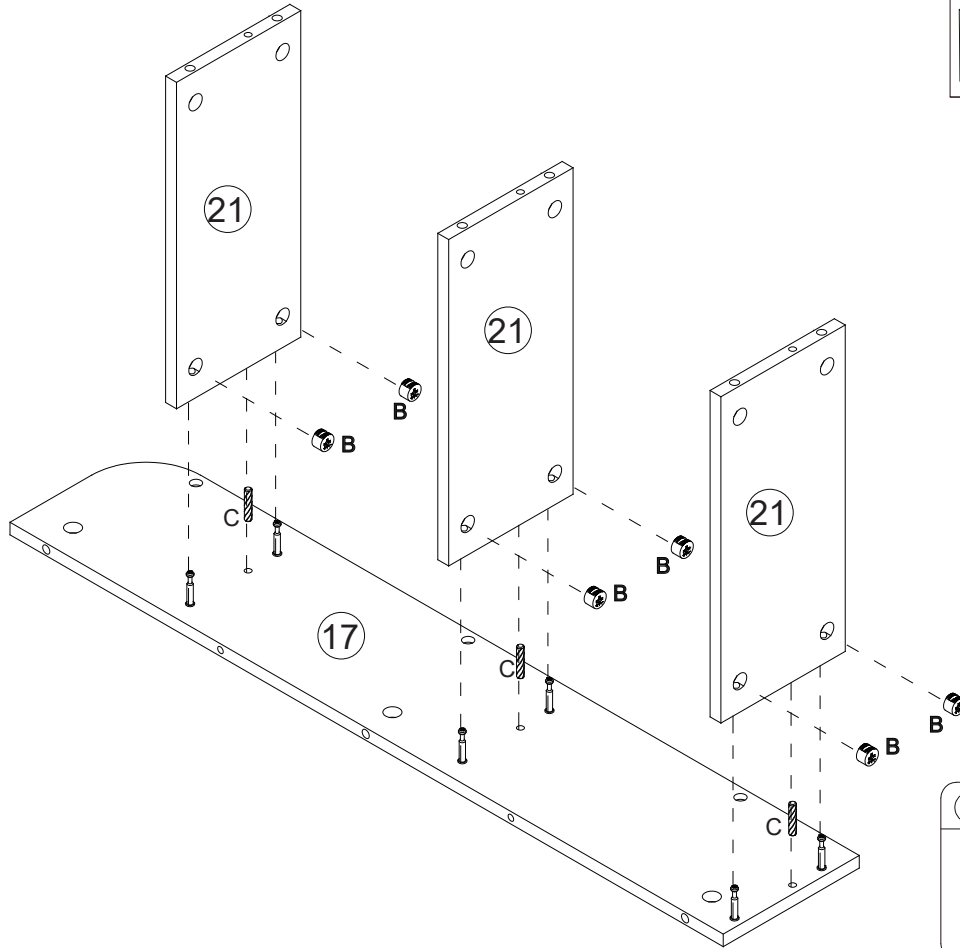

Cam Lock Fastening System

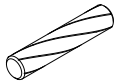
B	x6	C	x3
			

22

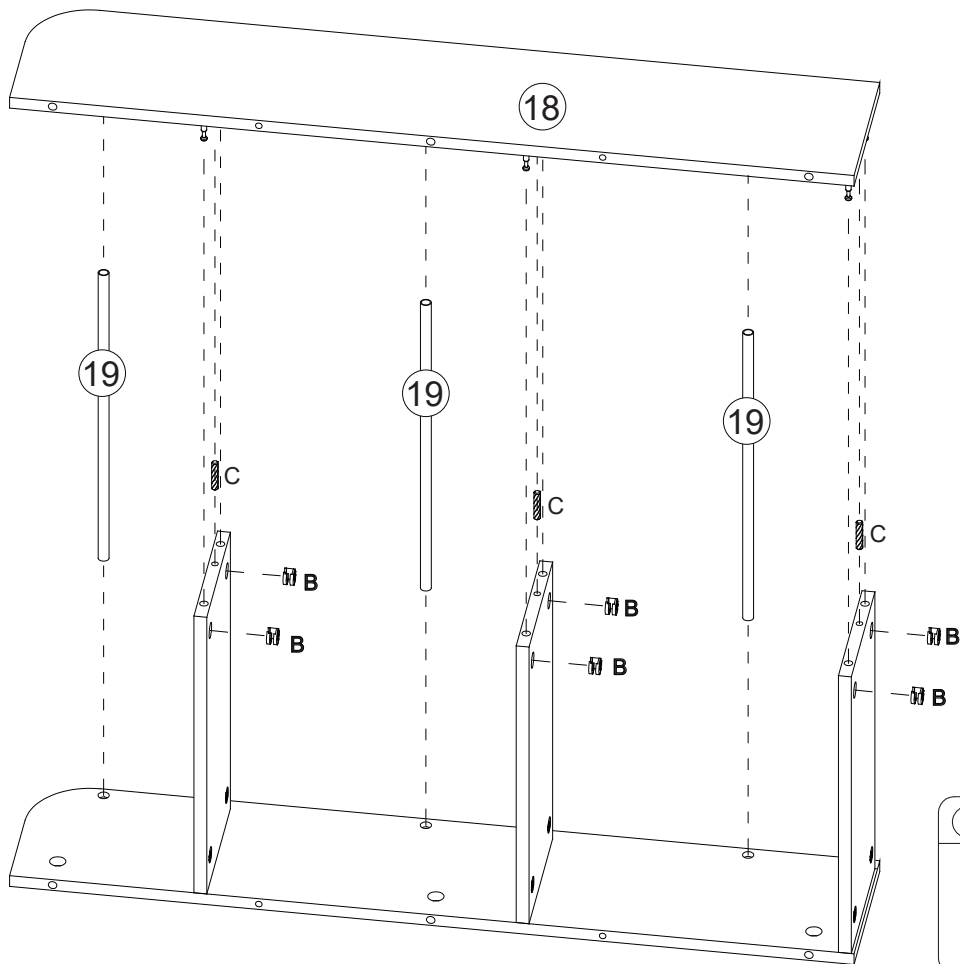

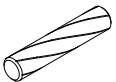
B	x6	C	x3
			

23

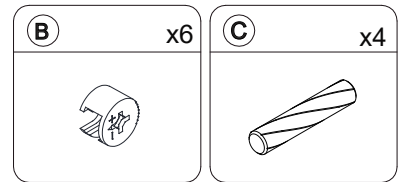
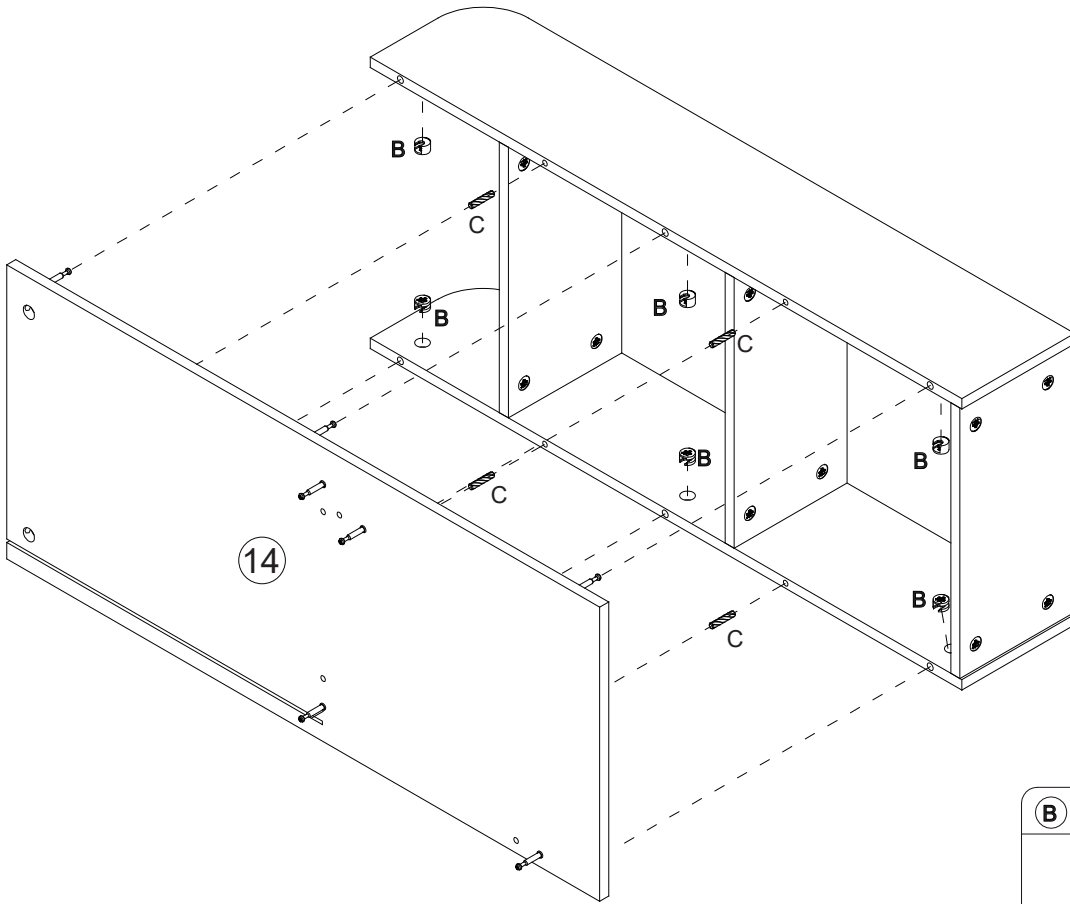

24

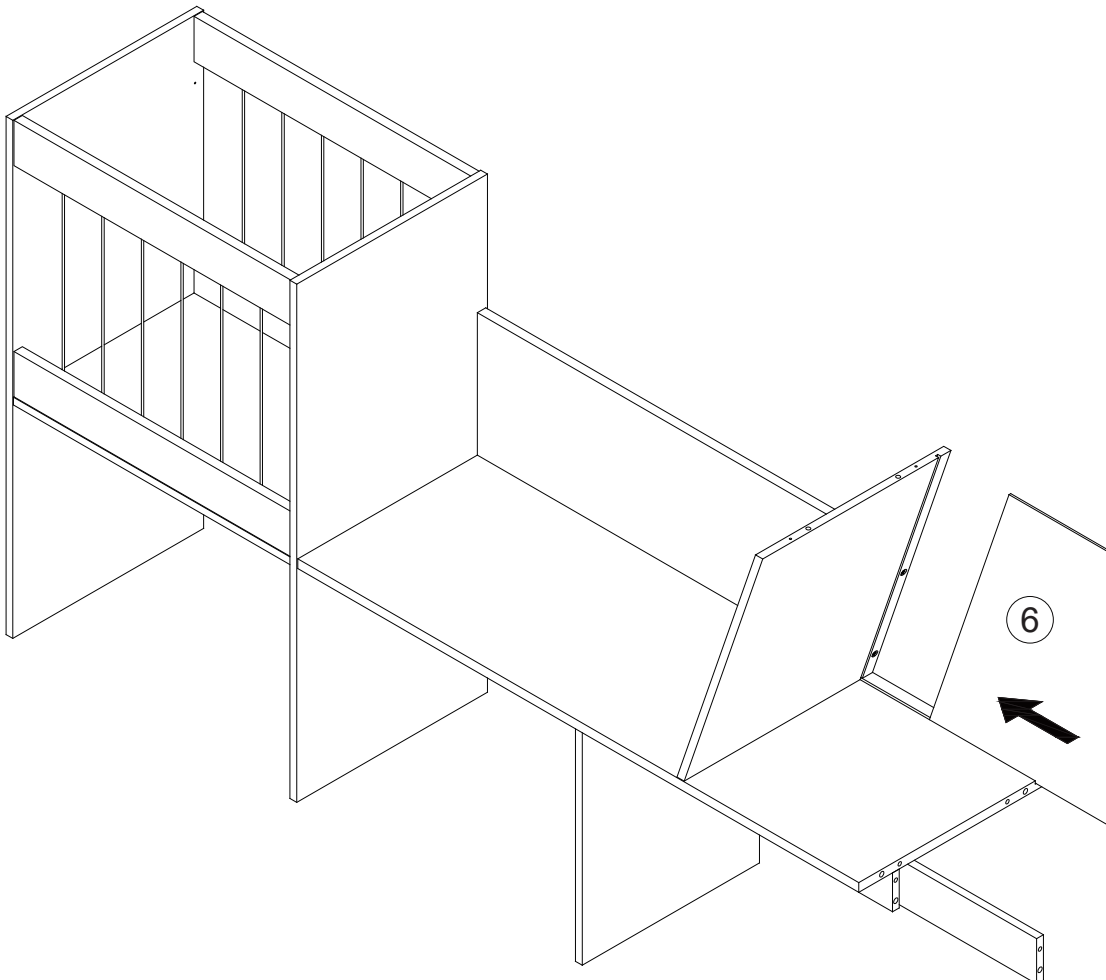

25

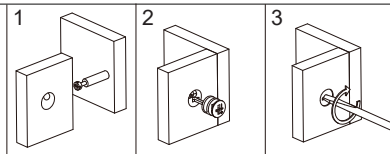

Cam Lock Fastening System

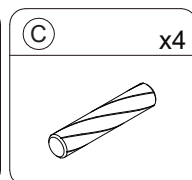
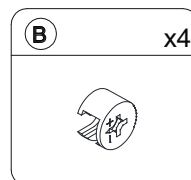
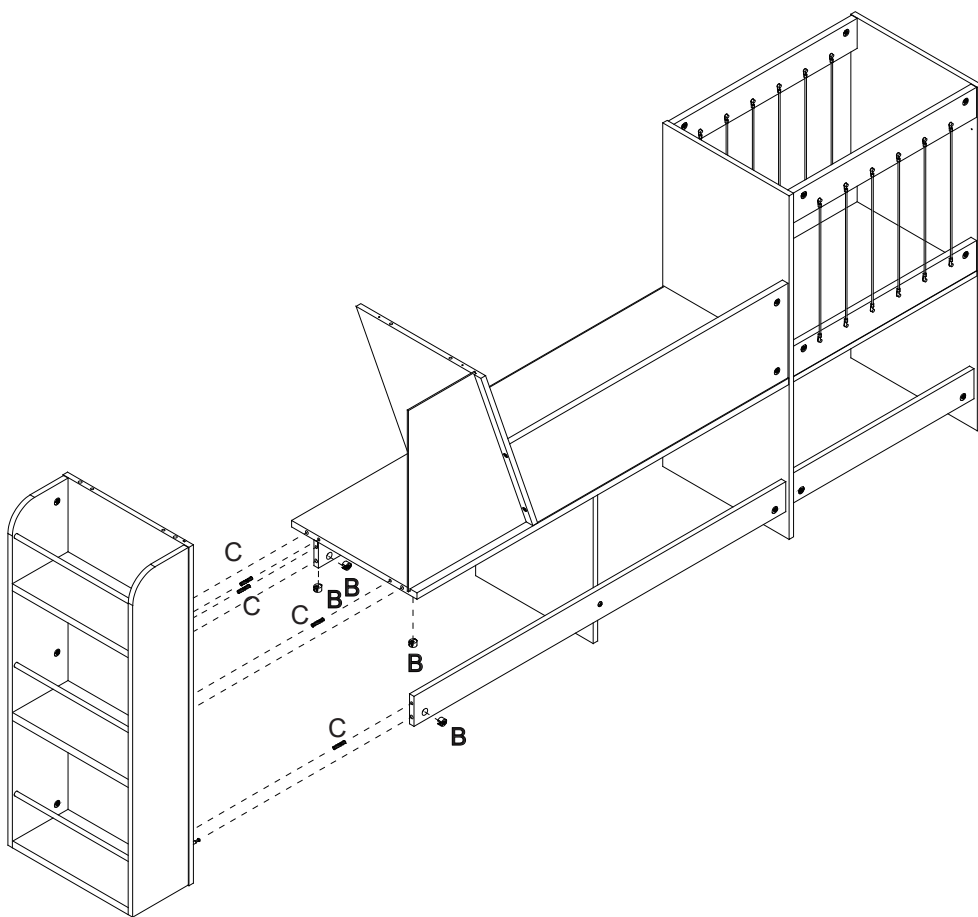

26

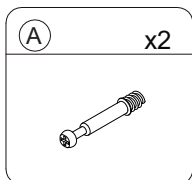
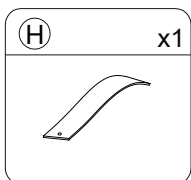
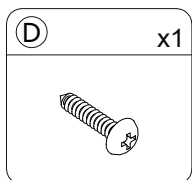
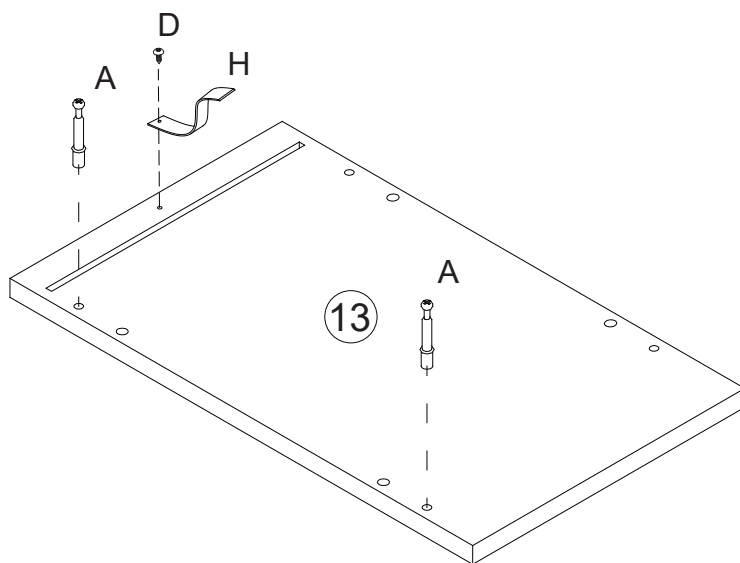
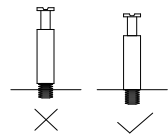

27

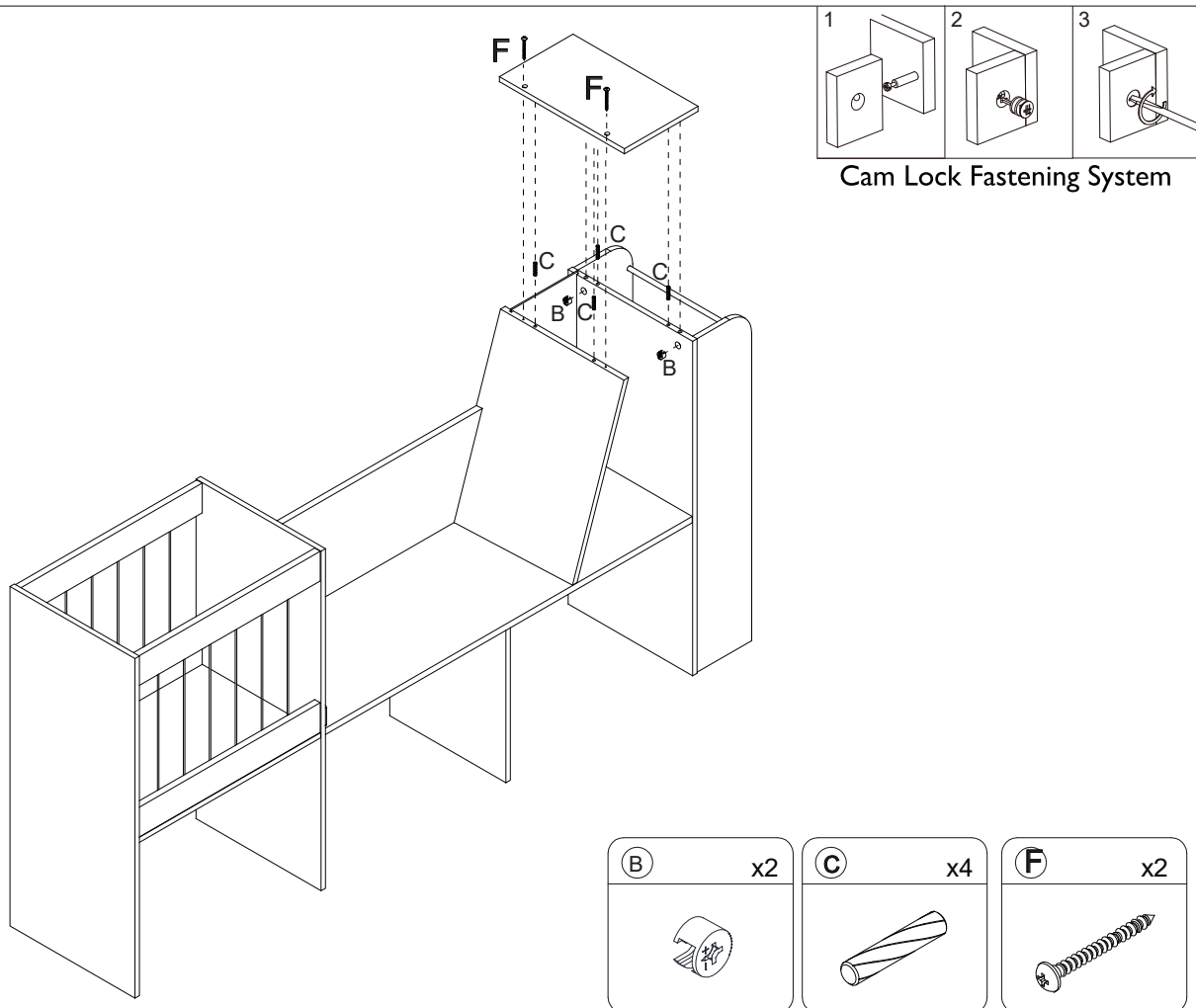

28

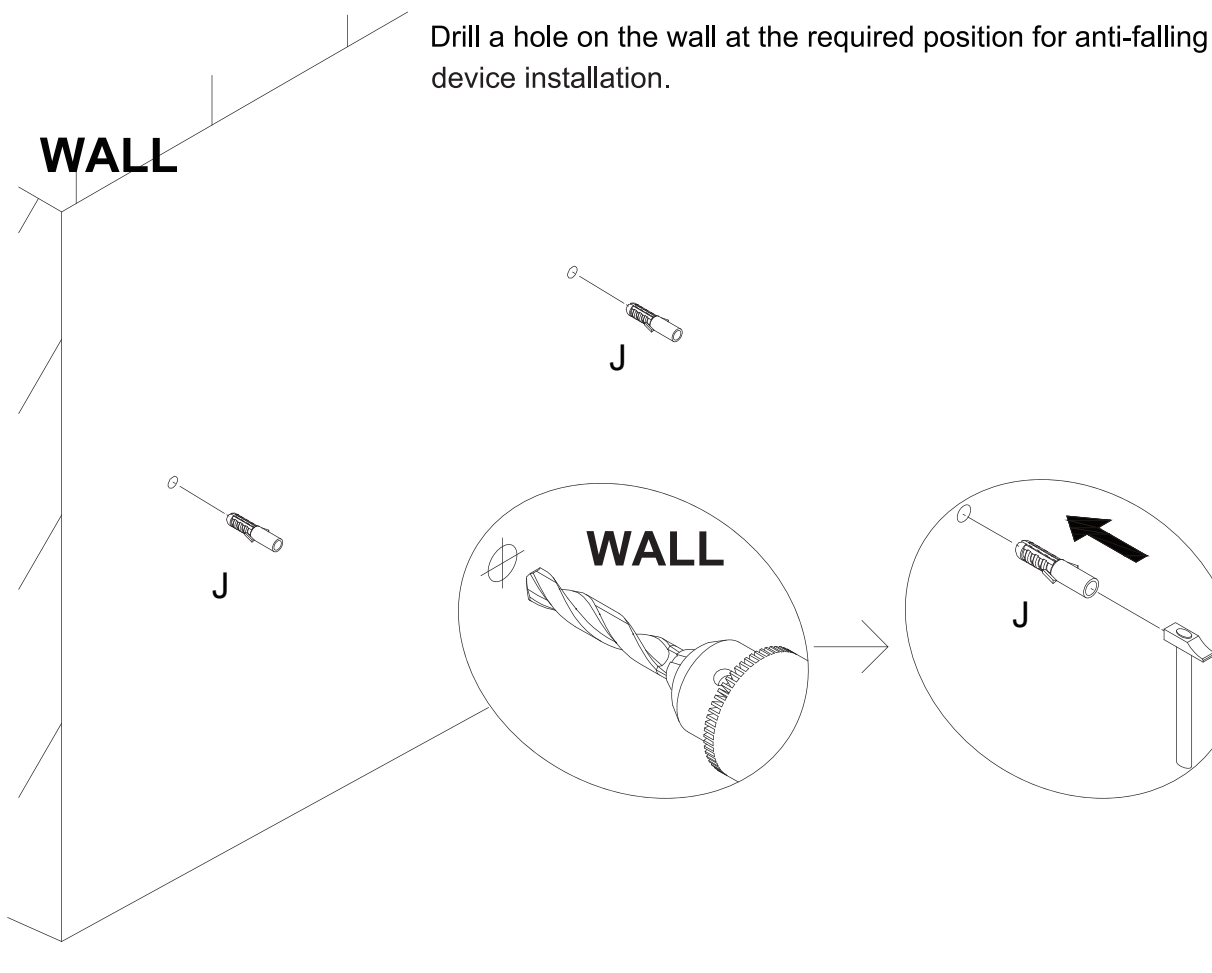

29

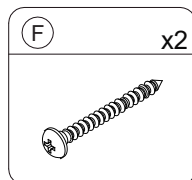
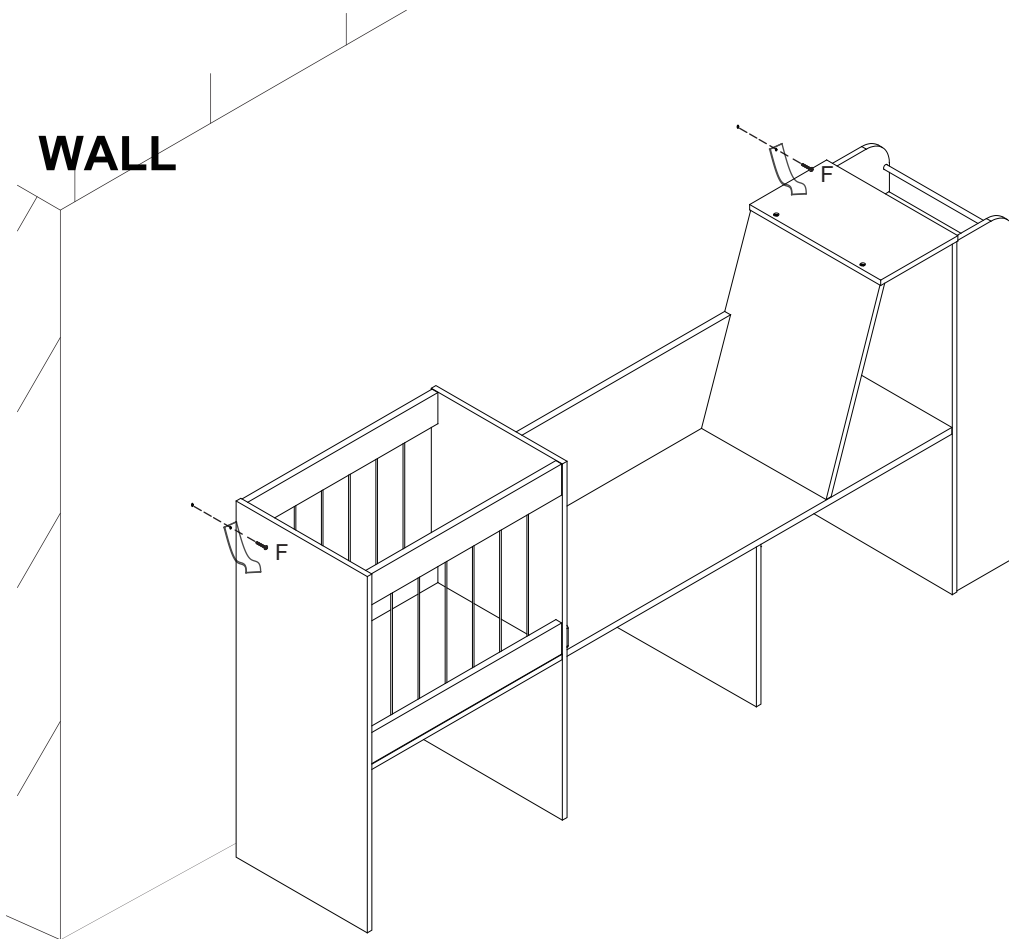

30

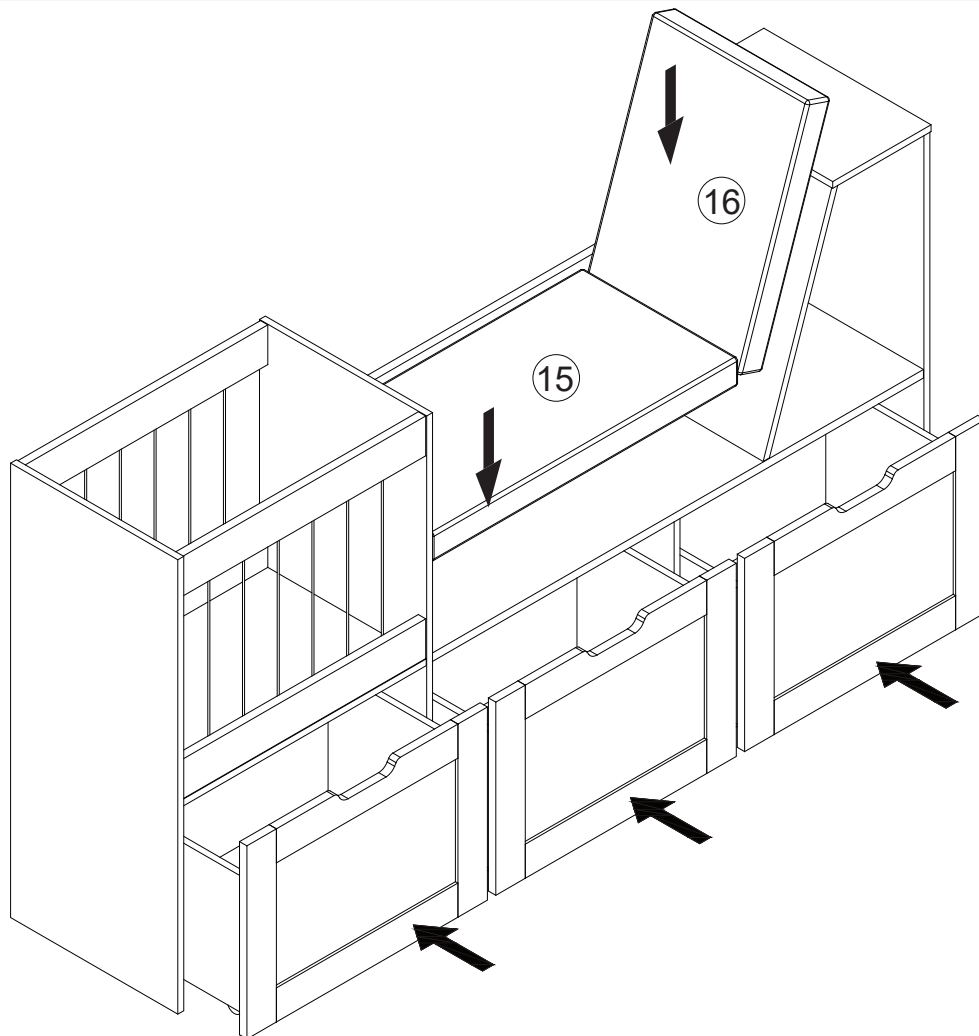

A Guide to Wall Mounting & Fixings

Important note:

If plastic wall plugs (rawl plugs) are supplied with your product, eg:



- these are suitable for use in masonry walls

If you are in any doubt about the correct wall plugs for your wall, seek professional advice.

Failure of the product due to using the incorrect fixings is the responsibility of the installer.



Important: when drilling into walls always check that there are no hidden wires or pipes etc.

Make sure that the screws and wall plugs being used are suitable for supporting your unit. Consult a qualified tradesperson if you are unsure.



Hints:

1. General rule: always use a larger screw and wall plug if you are not sure.
2. Ensure you use the recommended drill bit to match the wall plug and hole size.
3. Ensure you drill the hole horizontally; do not force the drill or enlarge the hole.
4. Take extra care when drilling high walls, ceilings and ceramic tiles. Ensure wall plugs are inserted beyond the thickness of the ceramic tiles to avoid the tiles splitting or cracking.
5. Ensure wall plugs are well fitted and are a tight fit in the drilled hole.

Types of walls

You can use one of the following types of wall plug if your walls are made of brick, breeze block, concrete, stone or wood.

No. 1 "General Purpose" wall plug

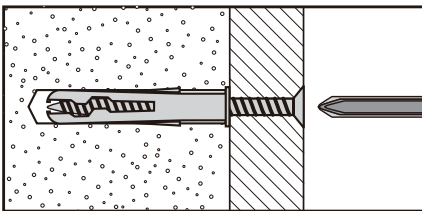

Generally aerated blocks should not be used to support heavy loads, use a specialist fitting in this case. For light loads, general purpose wall plugs can be used.

No. 3 "Cavity Fixing" wall plug

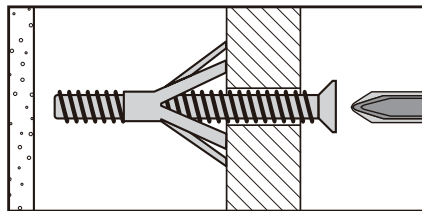

For use with plasterboard partitions or hollow wooden doors.

No. 5 "Hammer Fixing" wall plug

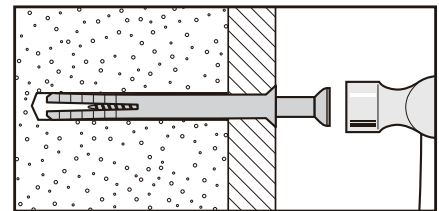

For use with walls stuck with plasterboard. The hammer fixing allows it to be fixed to the wall rather than the plasterboard. Always check the fixing is secure to the retaining wall.

No. 2 "Plasterboard" wall plug

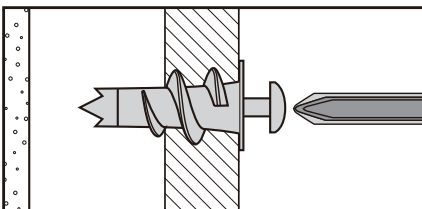

For use when attaching light loads onto plasterboard partitions.

No. 4 "Cavity Fixing - Heavy Duty" wall plug

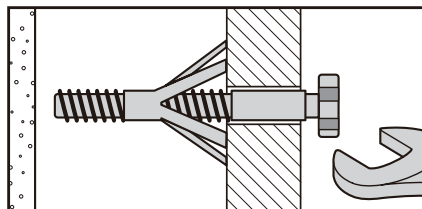

For use when fitting or supporting heavy loads such as shelving, wall cabinets and coat racks.

No. 6 "Shield Anchor" wall plug - heavy loads

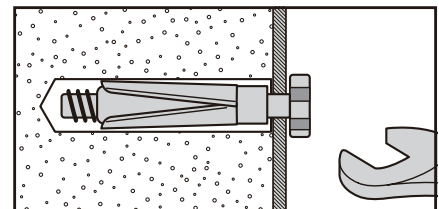

For use with heavier loads such as TV and HiFi speakers and satellite dishes etc.



Care & Maintenance

Safety: Always check the fitting and location to ensure your safety in and around the home.

Fitting: From time to time check the fitting to ensure the wall plugs or screws do not become loose.