

# ASSEMBLY INSTRUCTIONS

## STEP 1

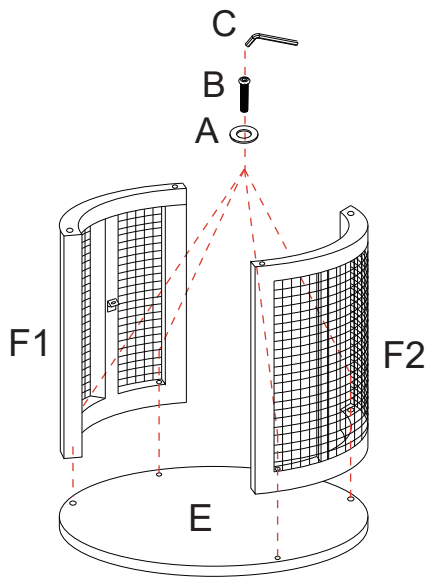

## STEP 2

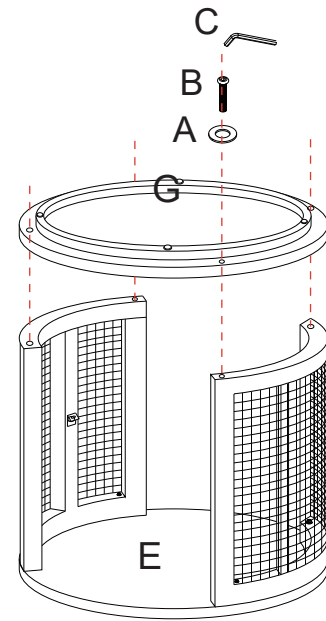

## STEP 3

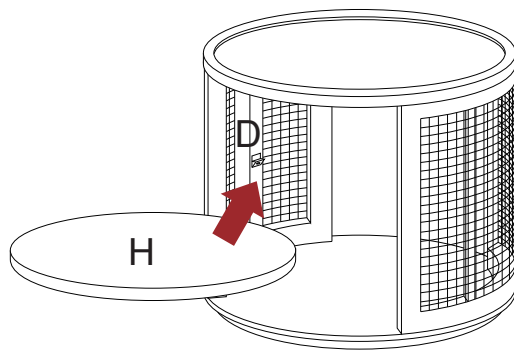

## STEP 4

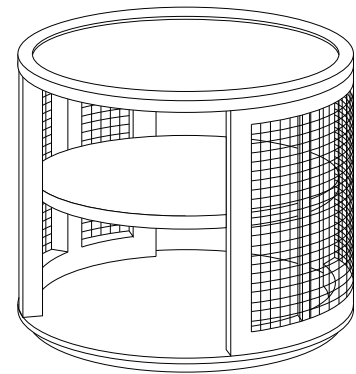

Step1: Rotate panel E 180° to align side panels F1 and F2 with the screw holes on panel E. Then pass through accessory B and accessory A in sequence, and use accessory C to fix side panels F1 and F2 to panel E respectively.

Step2: Rotate bottom plate G 180° to align with the screw holes on side panels F1 and F2 respectively. Then use accessory C to fix bottom plate F on side panels F1 and F2, passing through accessory B and accessory A in sequence.

Step3: Rotate the table 180° and clamp the middle layer H onto accessory D.

Step4: Check if the screws are tightened. After installation, place it stably and then it can be used normally.

Please use the accessories according to the number of screw holes on the table. The extra accessories are for backup.

Ax10

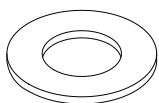

Bx10

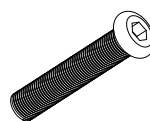

Cx1

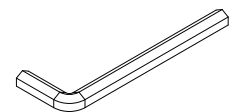

Ex1



F1x1  
F2x1

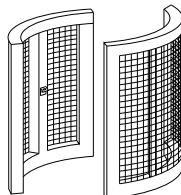

Gx1



Hx1

