

部件A孔位使用说明图

组装柜体前请仔细阅读此说明图

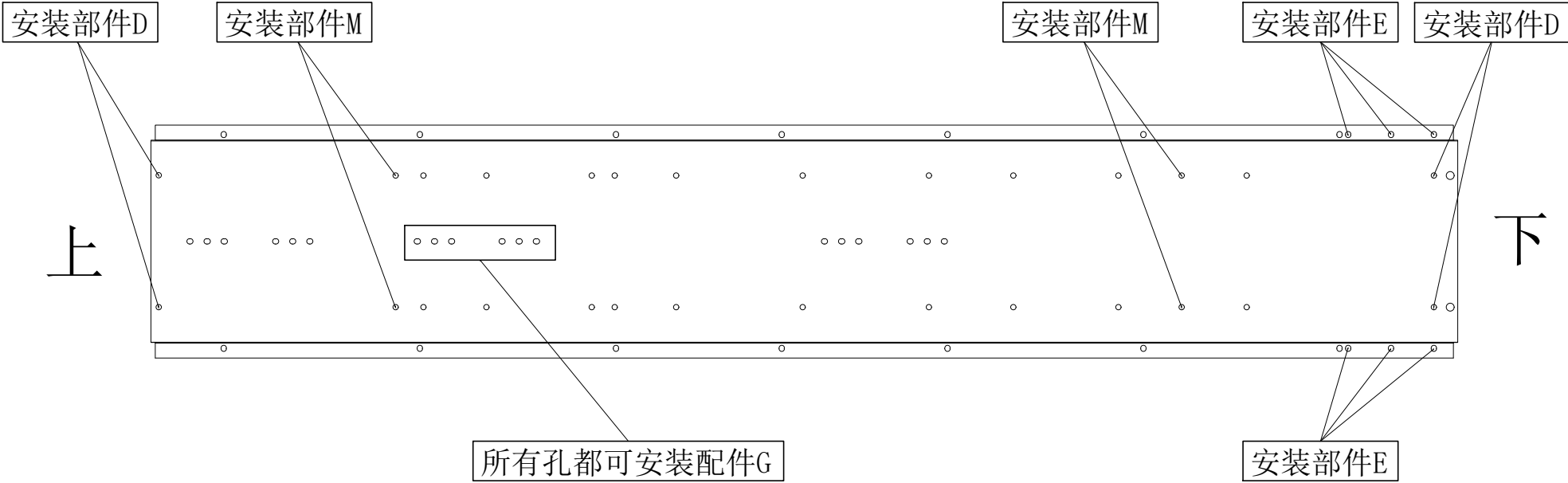

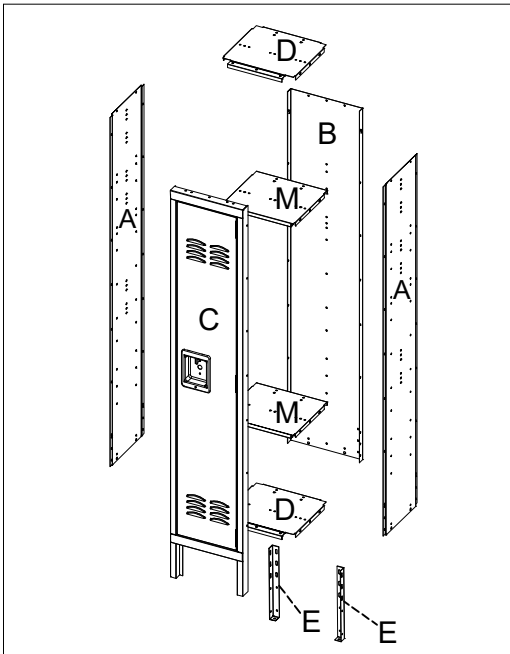

F x3
standby application

H x72

I x72

J x1

G x2

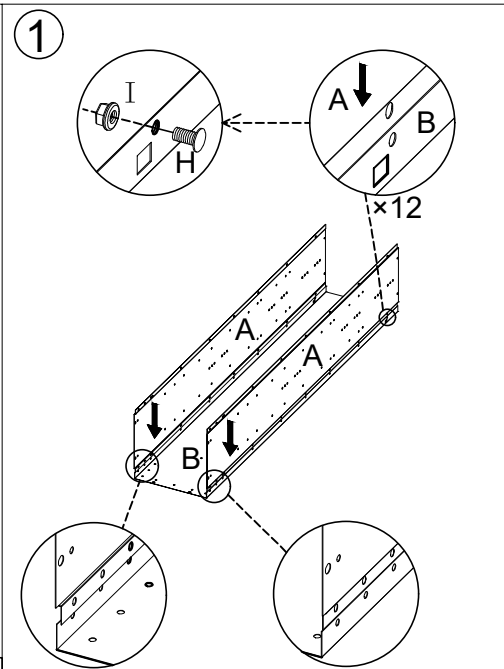

H x 12 | I x 12

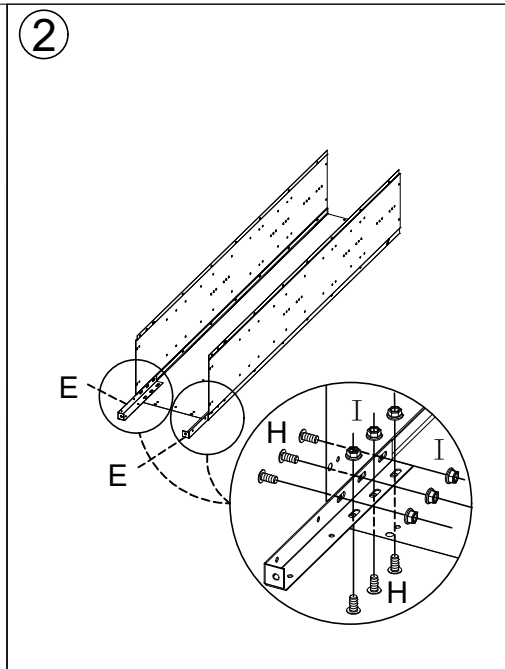

H x 12 | I x 12

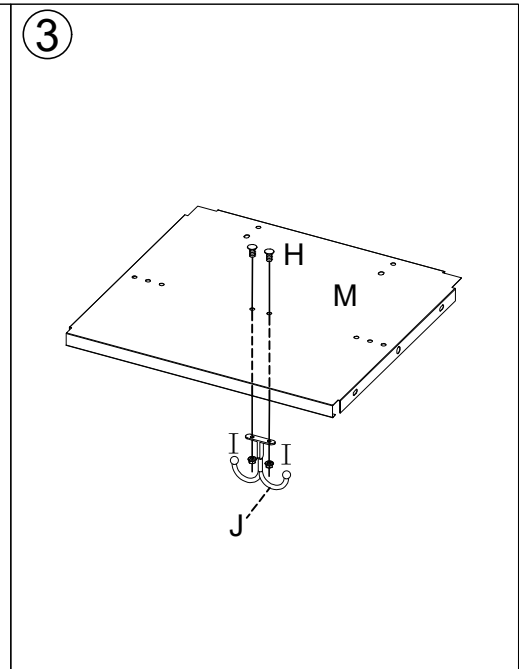

H x 2 | I x 2 | J x 1

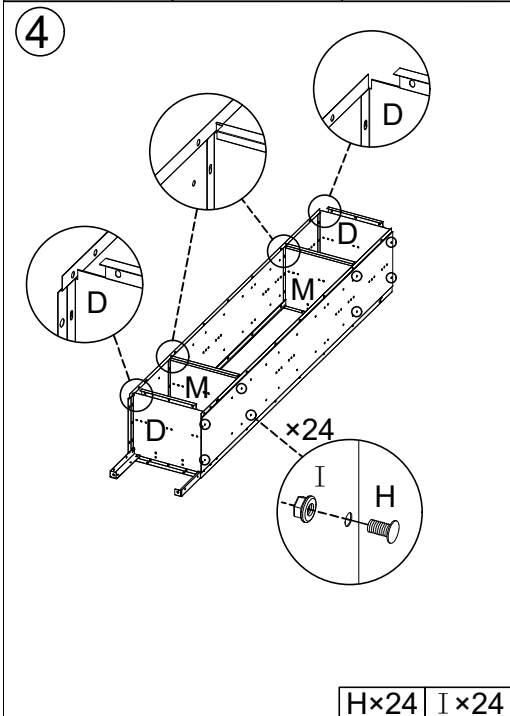

H x 24 | I x 24

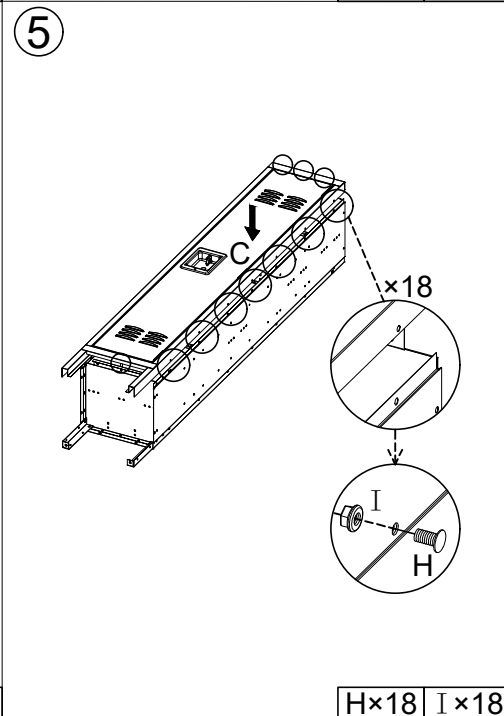

H x 18 | I x 18

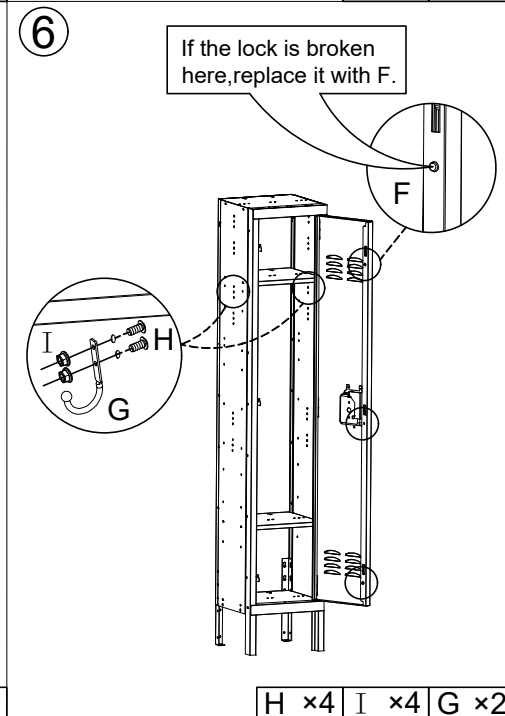

H x 4 | I x 4 | G x 2

