

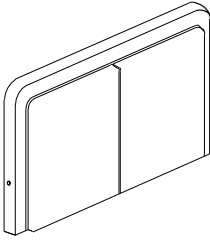

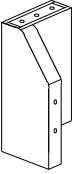
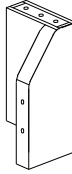
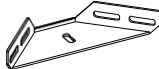
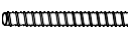

# ASSEMBLY INSTRUCTIONS

## LED EASTERN KING HEADBOARD

<b>A</b> Headboard Panel  1PC	<b>B</b> Headboard Leg LSF  1PC	<b>C</b> Headboard Leg RSF  1PC	<b>D</b> Metal Bracket (black) (In the Headboard Leg) 258 x 95 x 37 x 2mm  2PCS
<b>E</b> Threaded Rod Ø5/16" x 3 1/4"  6PCS	<b>F</b> Bolt Ø5/16" x 25mm  8PCS	<b>G</b> Flat Washer Ø5/16" x 22mm  14PCS	<b>H</b> Lock Washer Ø5/16" x 12mm  14PCS
<b>I</b> Hex Nut Ø5/16" x 12 x 5mm  6PCS	<b>J</b> Wrench M5 x 90mm  1PC	<b>K</b> L-Allen Key 5mm  1PC	

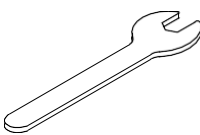
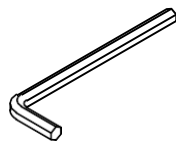
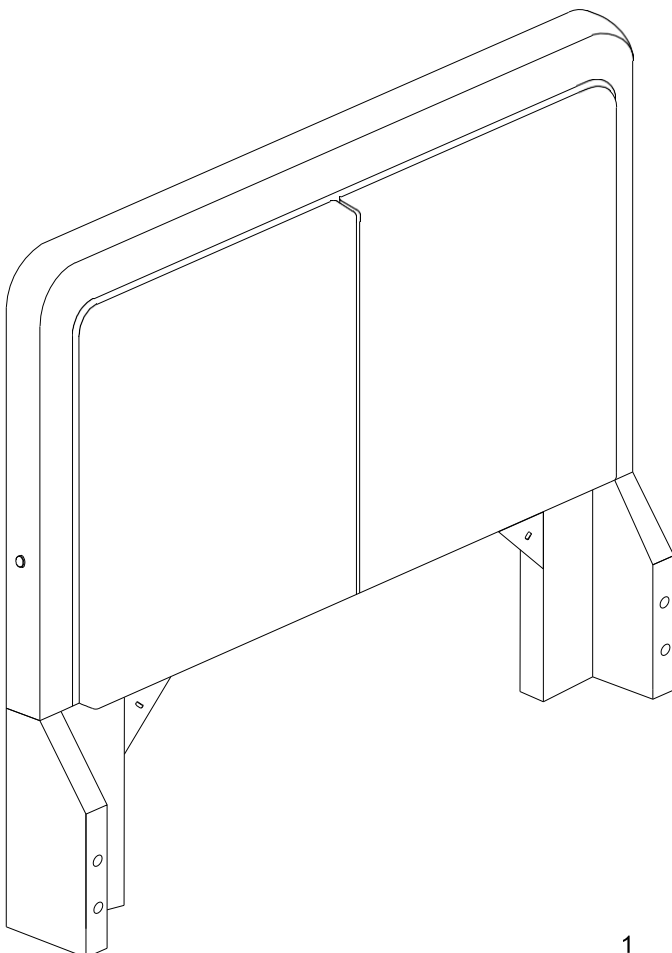

This page lists all the contents included in the box. Please take the time to identify the hardware as well as the individual components to this product. As you unpack and prepare for assembly, place the contents on a carpeted or padded area to protect them from damage.

- 1** Attach LSF & RSF Headboard Leg (B & C) to Headboard (A) using Threaded Rod (E), Flat Washer (G), Lock Washer (H) and Hex Nut (I) with Wrench (J).

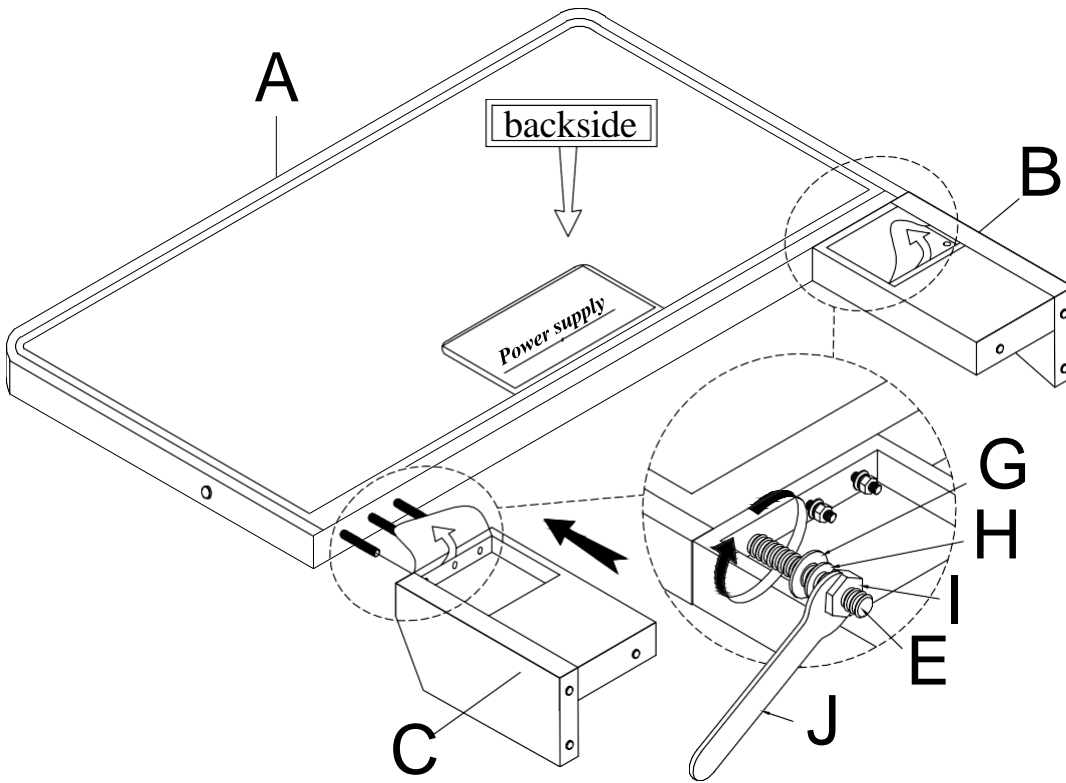

- 2** Attach Metal Bracket (D) to Headboard (A) and LSF & RSF Headboard Leg (B & C) using Bolt (F), Lock Washer (H) and Flat Washer (G) with L-Allen Key (K).

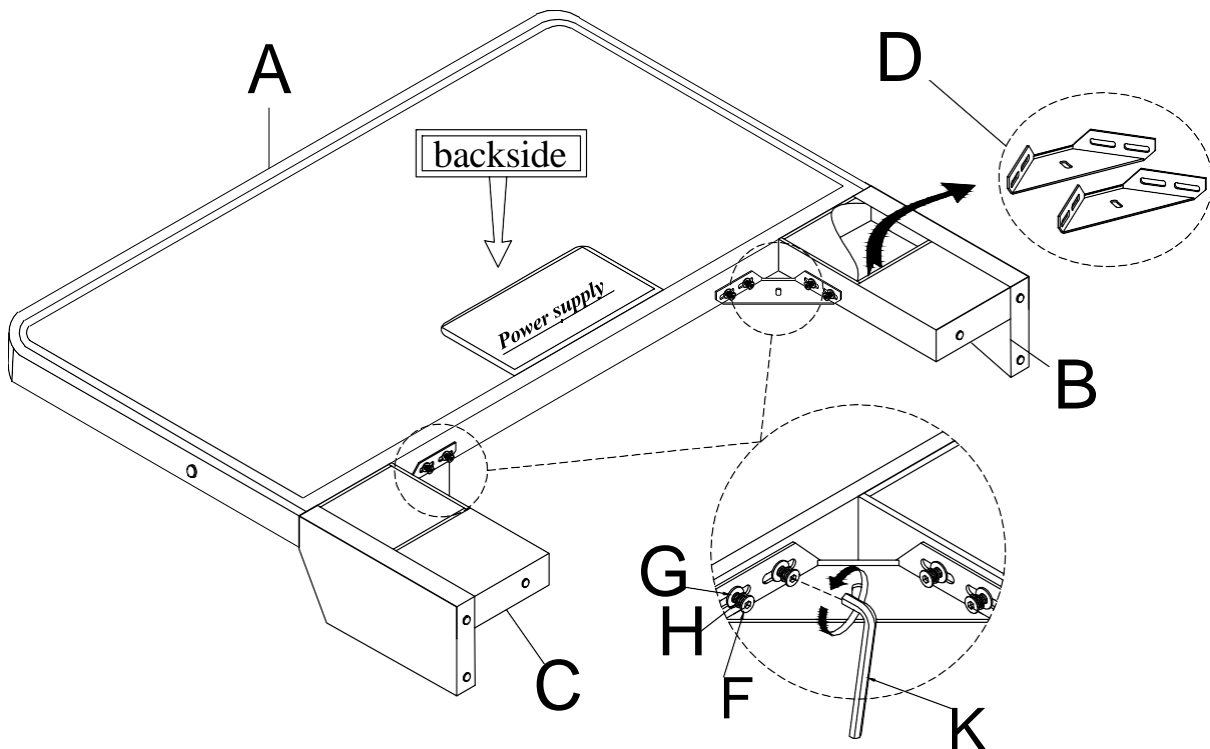





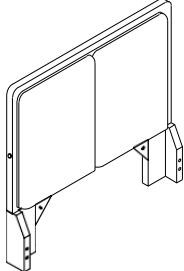
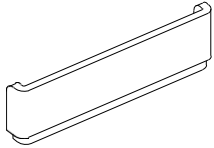
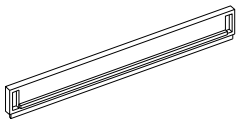
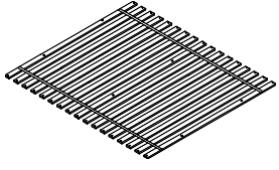
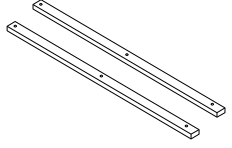
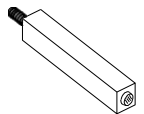
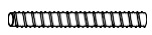

#### Cleaning & Care

Treat surfaces with care. Surfaces are resistant to scratches but are not scratch resistant. Clean surfaces with a dry or damp soft cloth. Do not use abrasive cleaners. Hardware may loosen over time. Periodically check that all connections are tight.

# ASSEMBLY INSTRUCTIONS

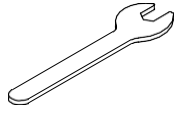
LED EASTERN KING FOOTBOARD & HEADBOARD LEGS & SLATS  
LED EASTERN KING RAILS & SUPPORT LEGS & CENTER BARS

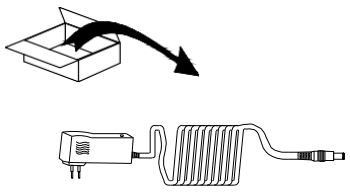
<b>A</b> Headboard  1PC	<b>B</b> Footboard  1PC	<b>C</b> Side Rail  2PCS	<b>D</b> Slat  1SET (17PCS)	<b>E</b> Center Bar  2PCS
<b>F</b> Center Support Leg  6PCS	<b>G</b> Threaded Rod $\text{Ø}5/16'' \times 80\text{mm}$  8PCS	<b>H</b> Flat Washer $5/16'' \times 22\text{mm}$  8PCS	<b>I</b> Lock Washer $\text{Ø}5/16'' \times 12\text{mm}$  8PCS	<b>J</b> Hex Nut $\text{Ø}5/16'' \times 12 \times 5\text{mm}$  8PCS
<b>K</b> Wrench $M5 \times 90\text{mm}$  1PC	<b>L</b> Screw $\text{Ø}8 \times 38\text{mm}$  34PCS	<b>M</b> Electricity Plug  1PC		

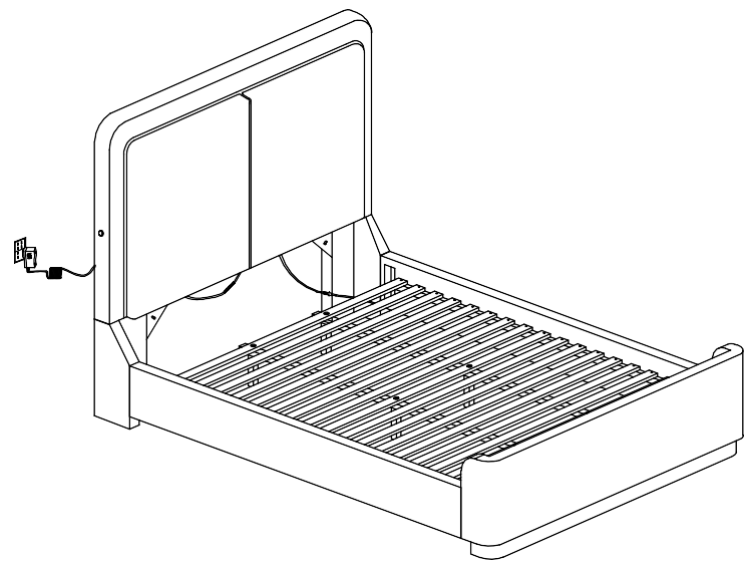

This page lists all the contents included in the box. Please take the time to identify the hardware as well as the individual components to this product. As you unpack and prepare for assembly, place the contents on a carpeted or padded area to protect them from damage.

**1**

Attach Side Rail (C) to Headboard (A) and Footboard (B) using Threaded Rod (G), Flat Washer (H), Lock Washer (I) and Hex Nut (J) with Wrench (K).

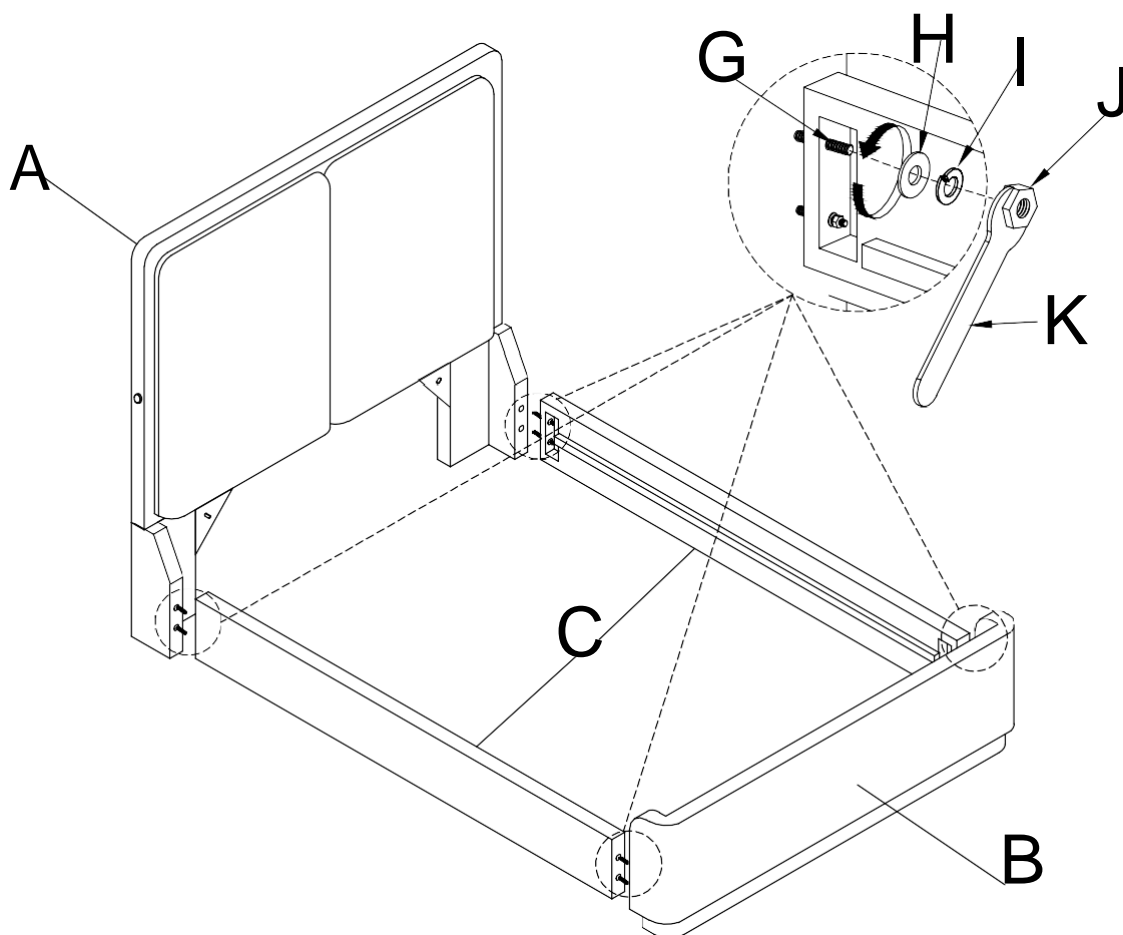
**2**

Rotate and attach Center Bar (E) and Center Support Leg (F) to Slat (D).

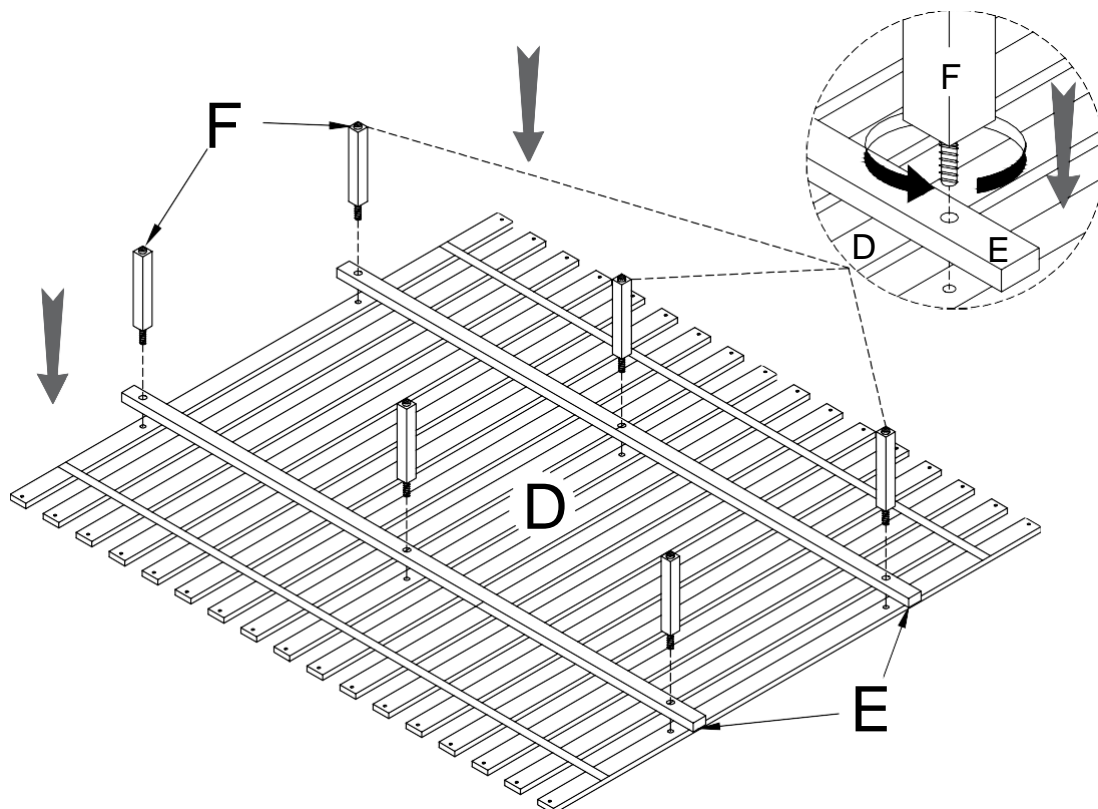

**3** Attach Slat (D) to Side Rail (C) using Screw (L) with a screwdriver (not provided).

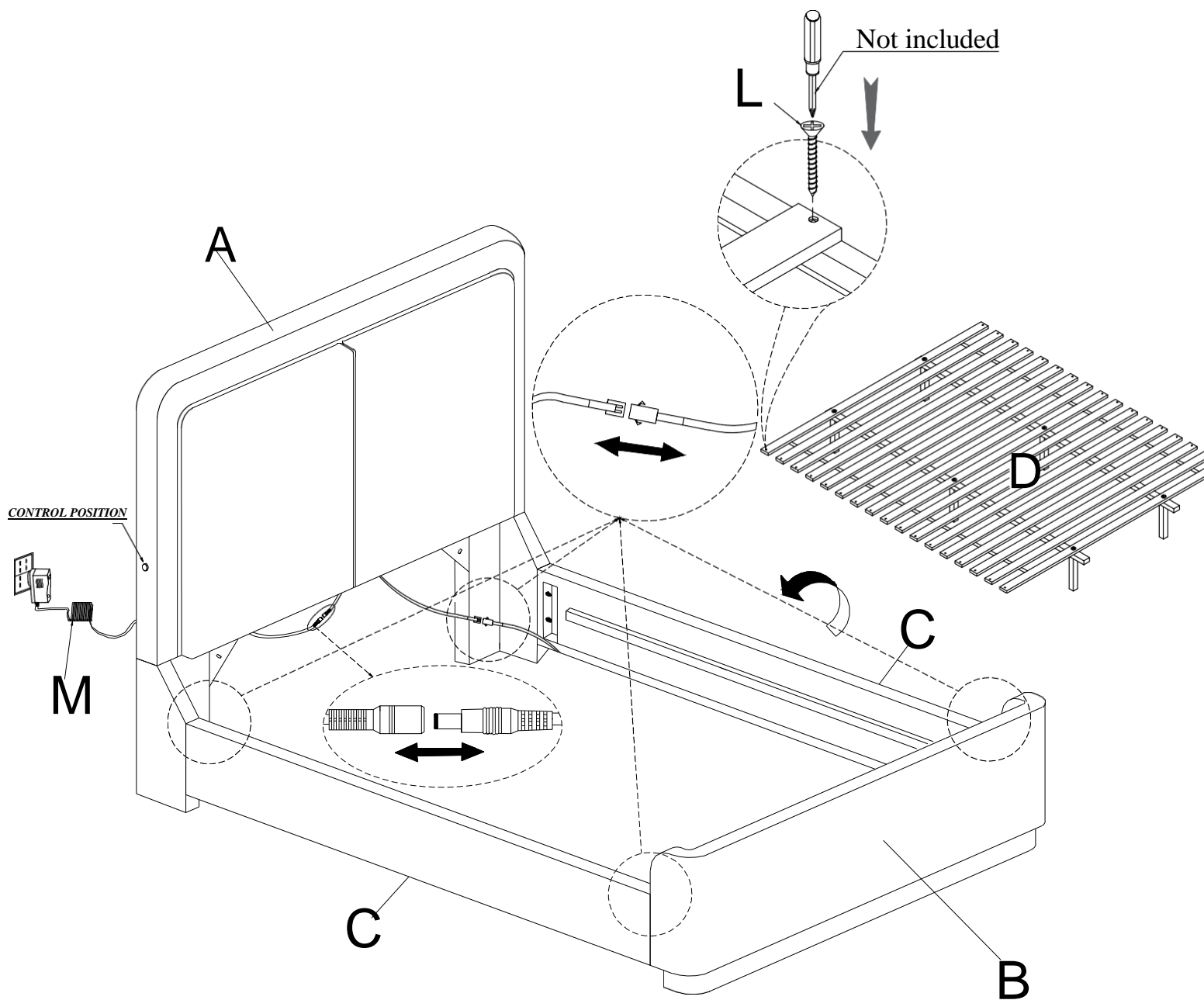

**Cleaning & Care**

Treat surfaces with care. Surfaces are resistant to scratches but are not scratch resistant. Clean surfaces with a dry or damp soft cloth. Do not use abrasive cleaners. Hardware may loosen over time. Periodically check that all connections are tight.