

N729P183735
WF319798
ASSEMBLY INSTRUCTIONS
(INSTRUCTIONS DE MONTAGE)
36 INCH BATH VANITY (COMBO)

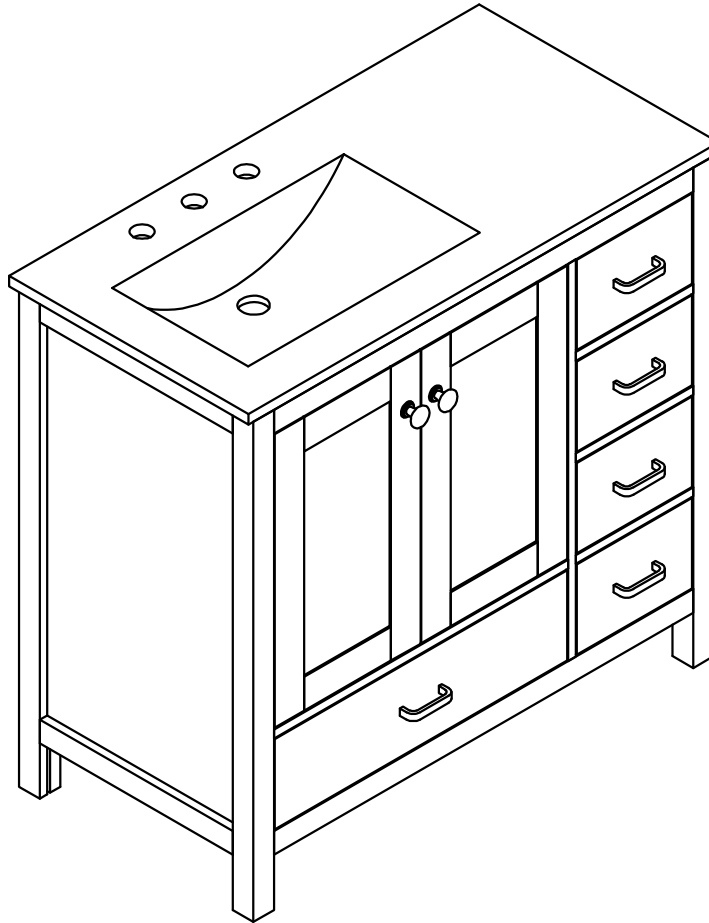

Thank you for purchasing this quality product. Be sure to check all packaging material carefully for small parts which may have come loose inside the carton during shipment. Separate, identify and count all parts and hardware. Compare with the parts list to be sure all parts are present.

"DO NOT TIGHTEN SCREWS UNTIL COMPLETELY ASSEMBLED"

Merci d'avoir acheté ce produit de qualité. Assurez-vous de vérifier soigneusement tout le matériel d'emballage pour détecter les petites pièces qui auraient pu se détacher à l'intérieur du carton pendant le transport. Séparez, identifiez et comptez toutes les pièces et le matériel. Comparez avec la liste des pièces pour vous assurer que toutes les pièces sont présentes.

"NE SERREZ PAS LES VIS AVANT D'ÊTRE COMPLÈTEMENT ASSEMBLÉES"

*** Use of power tool to assemble this product will invalidate any claim and damage this product making unsafe !!!
* Please assemble on a clean soft surface to avoid damage.**

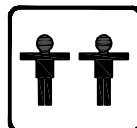

Tools Required

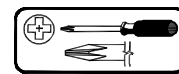

(Not included)

IMPORTANT:

PLEASE READ INSTRUCTION BEFORE STARTING THE ASSEMBLY
VEUILLEZ LIRE LES INSTRUCTIONS AVANT DE COMMENCER L'ASSEMBLAGE

Before Installation

Important - Please read these instructions fully before starting assembly

Thank you for purchasing this quality product. Be sure to check all packing materials carefully for small parts, which may have come loose inside the carton during shipment. Identify and count all items according to the PARTS LIST and/or HARDWARE LIST shown below. Check you have all the components and tools listed on the following pages.

- . We recommend that you assemble this product with the assistance of another person; this will make the assembly easier, and will help eliminate damage to the product or injury to persons during assembly.
- . Please do not over tighten screws or bolts until the assembly is completed.
- . Keep children and animal away from the work area, small parts could choke if swallowed.
- . Please put all parts on a non-abrasive floor before assembly, and follow the assembly steps to assemble your newly purchased product correctly and efficiently.

If you find that you have any trouble with assembly or missing or damaged parts please contact the seller.

Cam Lock Assembly Instructions

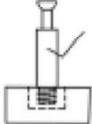
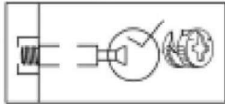
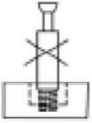
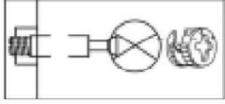
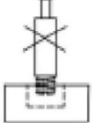
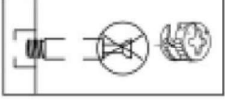
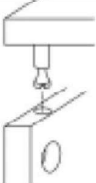
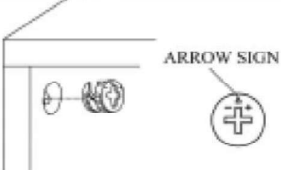
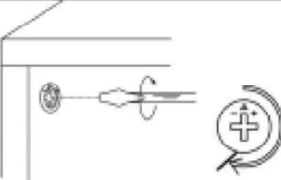
| | | |
|---|---|--|
|  |  | Insert Cam Bolt into hole as shown in diagram A. |
|  |  | Make sure not to insert the Cam Bolt: Too deep as shown in figure B as this will cause the Cam Lock to be misaligned and unable to interlock properly. |
|  |  | Also avoid inserting the Cam Bolt too close to the surface of the hole as shown in figure C, as this will cause the Cam Lock to be too loose, and not interlock properly. |
|  | | Connect the panels together. |
|  | ARROW SIGN | Insert the Cam Lock so the side opening fits over the head of the Cam Bolt. |
|  | | To tighten the Cam Lock, turn it clockwise on half a turn with a flat screwdriver. <i>*Do not use an automatic screwdriver as it may bend or break if too much power is imposed.</i> |

Before Installation

Important - Veuillez lire entièrement ces instructions avant de commencer l'assemblage.

Merci d'avoir acheté ce produit de qualité. Assurez-vous de vérifier soigneusement tous les matériaux d'emballage pour détecter les petites pièces qui pourraient s'être détachées à l'intérieur du carton pendant le transport. Identifiez et comptez tous les éléments conformément à la LISTE DES PIÈCES et/ou à la LISTE DU MATÉRIEL indiquée ci-dessous. Vérifiez que vous disposez de tous les composants et outils répertoriés dans les pages suivantes.

- Nous vous recommandons d'assembler ce produit avec l'aide d'une autre personne ; cela facilitera l'assemblage et aidera à éliminer les dommages au produit ou les blessures corporelles pendant l'assemblage.

- Veuillez ne pas trop serrer les vis ou les boulons jusqu'à ce que l'assemblage soit terminé.

- Tenir les enfants et les animaux éloignés de la zone de travail, les petites pièces pourraient s'étouffer en cas d'ingestion.

- Veuillez placer toutes les pièces sur un sol non abrasif avant l'assemblage et suivre les étapes d'assemblage pour assembler correctement et efficacement votre produit nouvellement acheté.

Si vous constatez des problèmes d'assemblage ou des pièces manquantes ou endommagées, veuillez contacter le vendeur.

Instructions d'assemblage du verrou à came

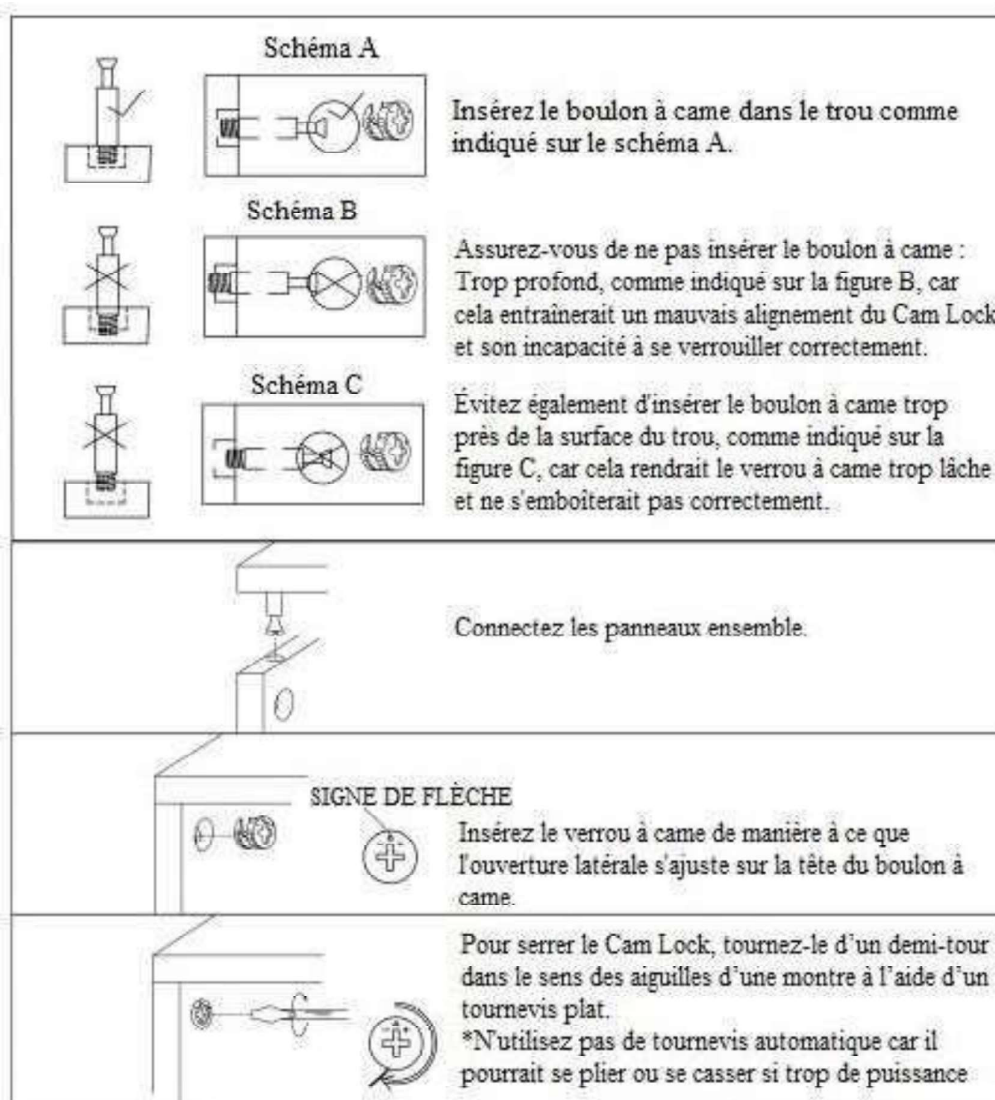



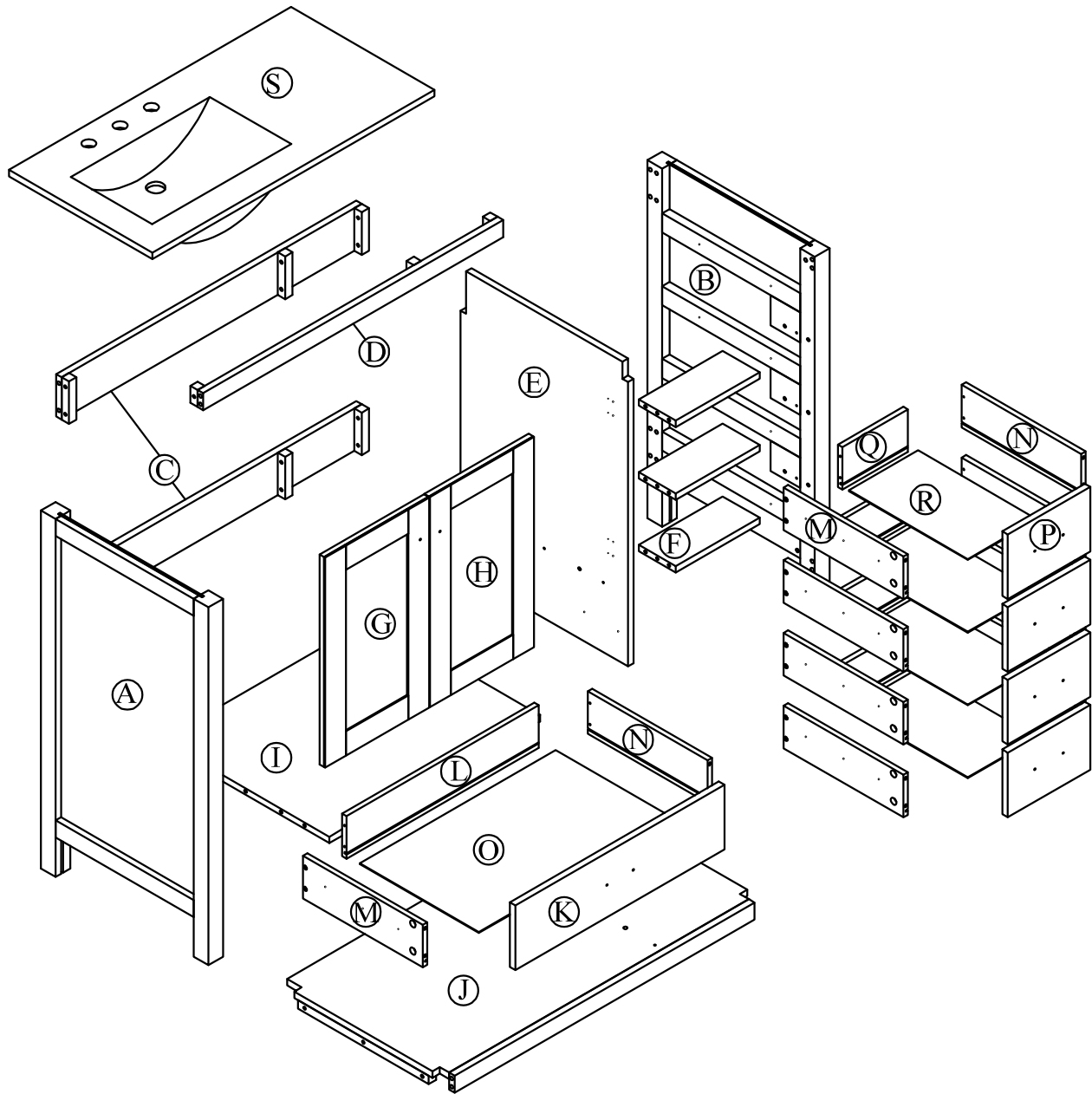



Detail View - VANITY
(Vue détaillée - Vanité)

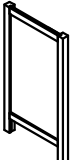
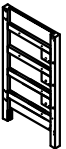
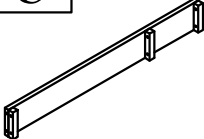
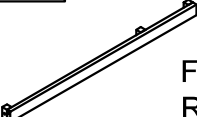

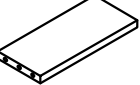
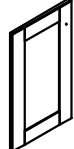
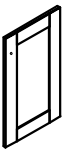
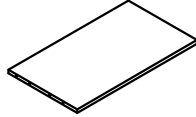
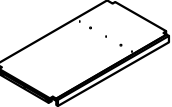
Identifying the Hardware - Identify the hardware using the illustrations below
(Identification du matériel - Identifiez le matériel à l'aide des illustrations ci-dessous)

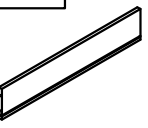
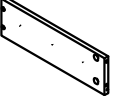

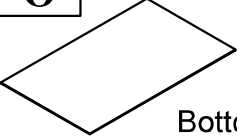
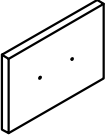



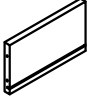
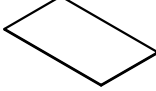
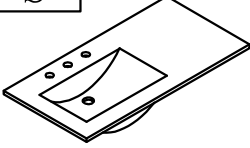



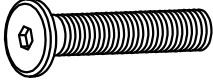
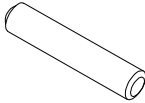
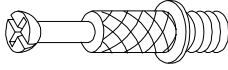
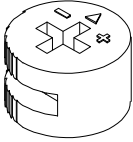
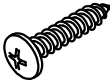
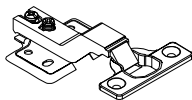

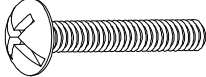

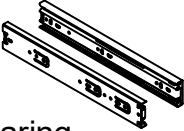



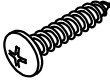

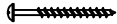
Part List (Liste des pièces)

| | |
|---|---|
| <p>A</p>  <p>Side Panel (L) - 1PC Panneau latéral</p> | <p>B</p>  <p>Side Panel (R) - 1PC Panneau latéral</p> |
| <p>C</p>  <p>Back Panel - 2PCS Panneau arrière</p> | <p>D</p>  <p>Front Rail - 1PC Rail avant</p> |
| <p>E</p>  <p>Partition Panel - 1PC Panneau de séparation</p> | <p>F</p>  <p>Horizontal Partition - 3PCS Cloison Horizontale</p> |
| <p>G</p>  <p>Door (L) - 1PC Porte</p> | <p>H</p>  <p>Door (R) - 1PC Porte</p> |
| <p>I</p>  <p>Adjustable Shelf - 1PC Étagère réglable</p> | <p>J</p>  <p>Bottom frame - 1PC Cadre inférieur</p> |
| <p>K</p>  <p>Front Drawer Frame - 1PC Cadre avant du tiroir</p> | <p>L</p>  <p>Back Drawer Panel - 1PC Panneau arrière du tiroir</p> |
| <p>M</p>  <p>Side Drawer Panel (L) - 5PCS Panneau latéral du tiroir</p> | <p>N</p>  <p>Side Drawer Panel (R) - 5PCS Panneau latéral du tiroir</p> |
| <p>O</p>  <p>Bottom Drawer Panel - 1PC Panneau de tiroir inférieur</p> | <p>P</p>  <p>Front Drawer Frame - 4PCS Cadre avant du tiroir</p> |

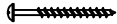
Part List (Liste des pièces)

| | |
|---|---|
| <p>Q</p>  <p>Back Drawer Panel - 4PCS Panneau arrière du tiroir</p> | <p>R</p>  <p>Bottom Drawer Panel - 4PCS Panneau de tiroir inférieur</p> |
| <p>S</p>  <p>Sink- 1PC Lavabo</p> | |

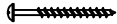
Part List (Liste des pièces)



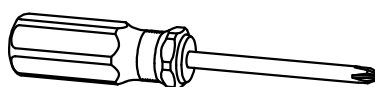

| | | | | | | | | |
|--|---|---|---|---|---|---|--|--|
| <p>1</p>  <p>Allen Bolts 1/4"x30 - 21PCS Boulons Allen</p> | <p>2</p>  <p>Wooden Ø8 x 34 +2 PCSEnbois</p> | <p>3</p>  <p>Cam Lock Screws - 32PCS Vis de verrouillage à came</p> | | | | | | |
| <p>4</p>  <p>Cam Lock -32PCS Serrure à came</p> | <p>5</p>  <p>Screws M4x25 - 3+2PCS Vis</p> | <p>6</p>  <p>Hinges - 4PCS Charnières</p> | | | | | | |
| <p>7</p>  <p>Screws M3.5x12 - 24CS Vis</p> | <p>8</p>  <p>Screws M4x20 - 12PCS boulons à tête de vis</p> | <p>9</p>  <p>Allen key M4 - 1PC Clé Allen</p> | | | | | | |
| <p>10</p>  <p>Ball Bearing Soft Close - 5 SET</p> | <p>11</p>  <p>Handle - 5PCS Poignée</p> | <p>12</p>  <p>Handle - 2PCS Poignée</p> | | | | | | |
| <p>13</p>  <p>Screws M3.5x12 - 60+2PCS Vis</p> | <p>14</p>  <p>Screws M4x20 - 20+2PCS Vis</p> | <p>Hardware list: (Anti tipping kit 2 set in the bag)</p> <table border="1"> <tr> <td data-bbox="1029 1375 1241 1451"> <p>A</p>  <p>Brackets - 04pcs</p> </td> <td data-bbox="1246 1375 1453 1451"> <p>B</p>  <p>Steel cables - 02pcs</p> </td> </tr> <tr> <td data-bbox="1029 1458 1241 1534"> <p>C</p>  <p>Screws - 02pcs</p> </td> <td data-bbox="1246 1458 1453 1534"> <p>D</p>  <p>Screws - 02pcs</p> </td> </tr> <tr> <td data-bbox="1029 1541 1241 1597"> <p>E</p>  <p>wall anchor - 02pcs</p> </td> <td></td> </tr> </table> | <p>A</p>  <p>Brackets - 04pcs</p> | <p>B</p>  <p>Steel cables - 02pcs</p> | <p>C</p>  <p>Screws - 02pcs</p> | <p>D</p>  <p>Screws - 02pcs</p> | <p>E</p>  <p>wall anchor - 02pcs</p> | |
| <p>A</p>  <p>Brackets - 04pcs</p> | <p>B</p>  <p>Steel cables - 02pcs</p> | | | | | | | |
| <p>C</p>  <p>Screws - 02pcs</p> | <p>D</p>  <p>Screws - 02pcs</p> | | | | | | | |
| <p>E</p>  <p>wall anchor - 02pcs</p> | | | | | | | | |

ASSEMBLY TOOLS REQUIRED (NOT INCLUDED)



STEP: 1

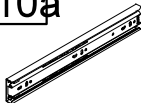

(ÉTAPE : 1)

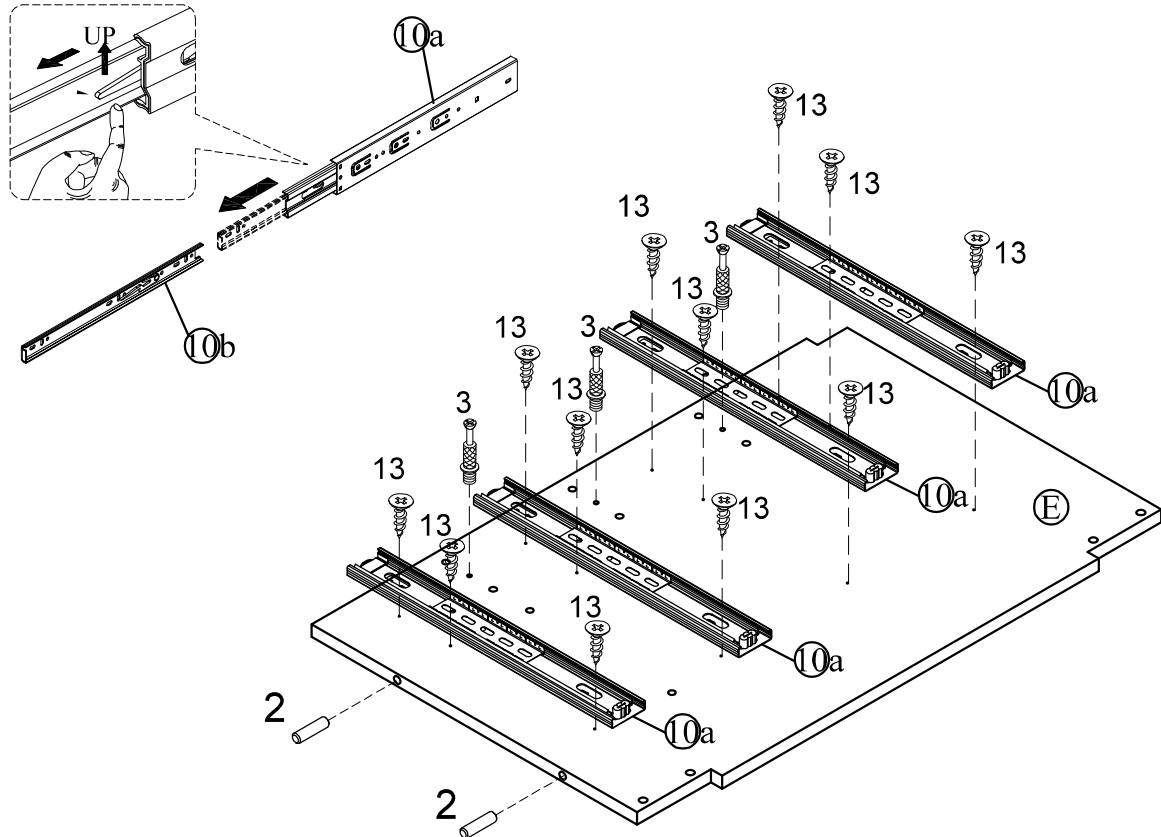
| | | | |
|---|--|--|--|
| 3 | 2 | 10a | 13 |
|  |  |  |  |
| Ø8 X 30 | | | M3.5 X 12 |
| 3 PCS | 2 PCS | 04 PCS | 12 PCS |

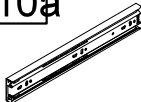

STEP: 2

(ÉTAPE : 2)

| | | |
|--|---|---|
| 3 | 10a | 13 |
|  |  |  |
| | | M3.5 X 12 |
| 3 PCS | 1 PC | 3 PCS |

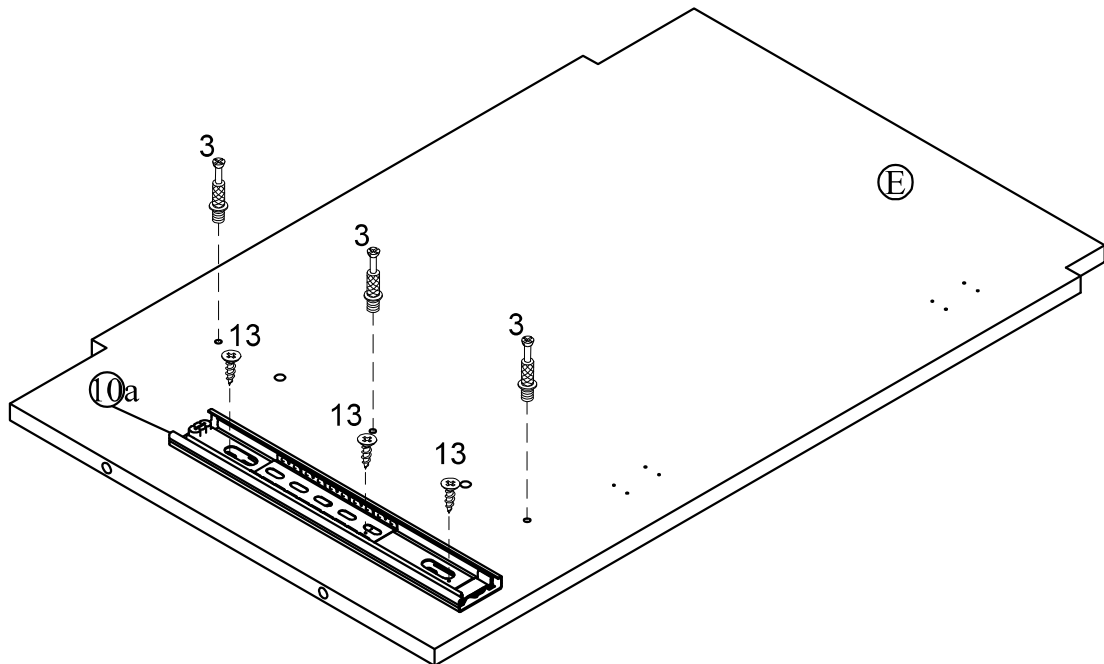

STEP: 3

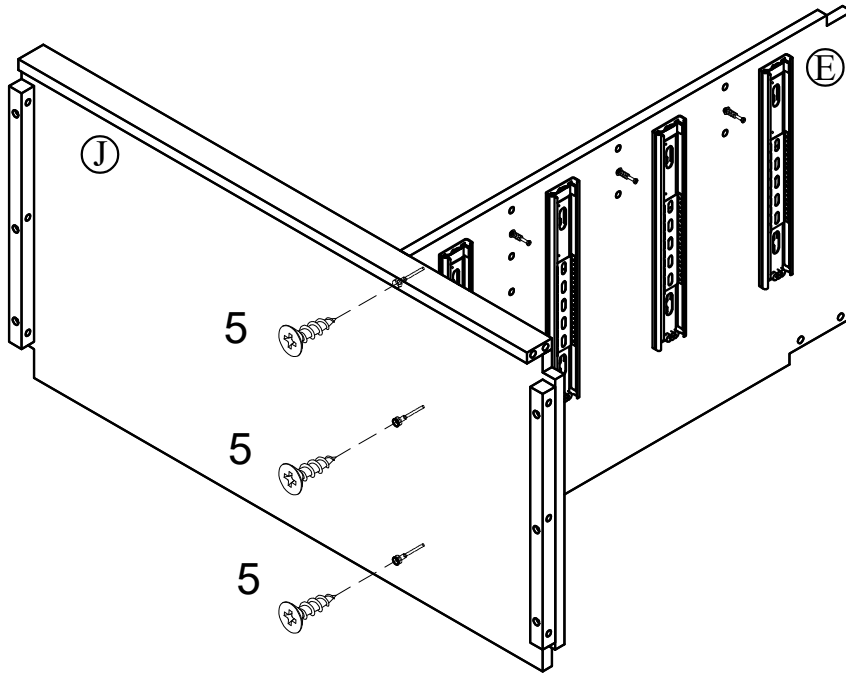

(ÉTAPE : 3)

| | |
|---------|--|
| 5 |  |
| M4 X 25 | |
| 3 PCS | |



STEP: 4

(ÉTAPE : 4)

| | | | | | |
|---------|--|--------------|---|----------|---|
| 2 |  | 9 |  | 1 |  |
| Ø8 X 30 | | Allen key M4 | | 1/4 X 30 | |
| 6 PCS | | 1 PC | | 5 PCS | |

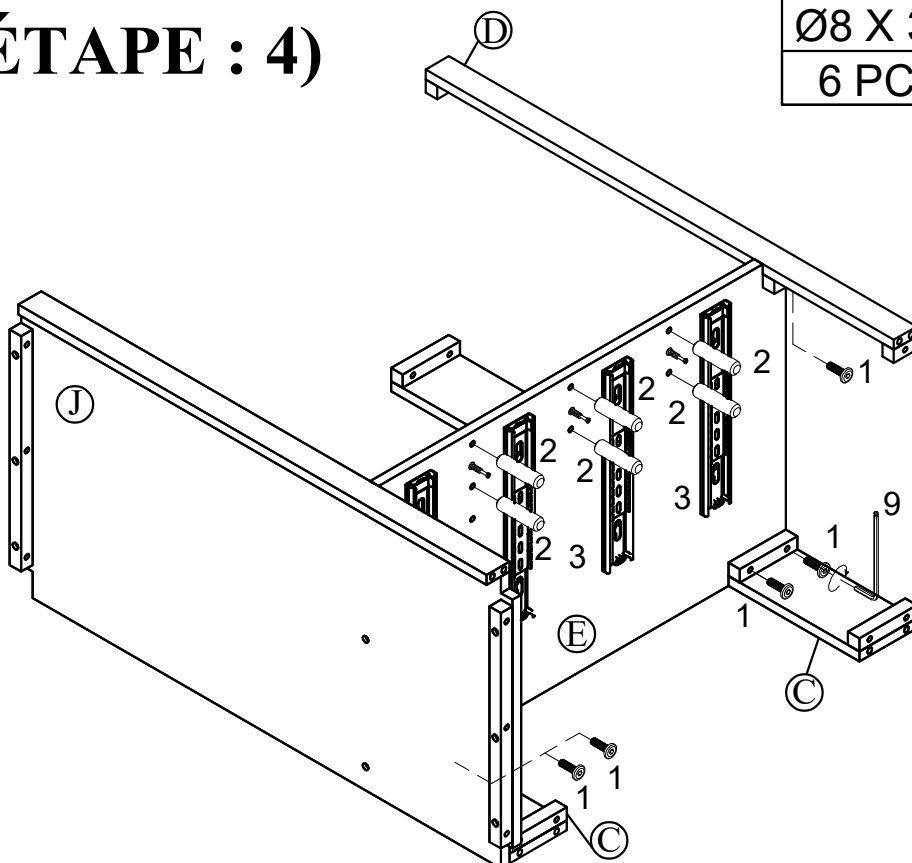

STEP: 5

(ÉTAPE : 5)

2



Ø8 X 30

2 PCS

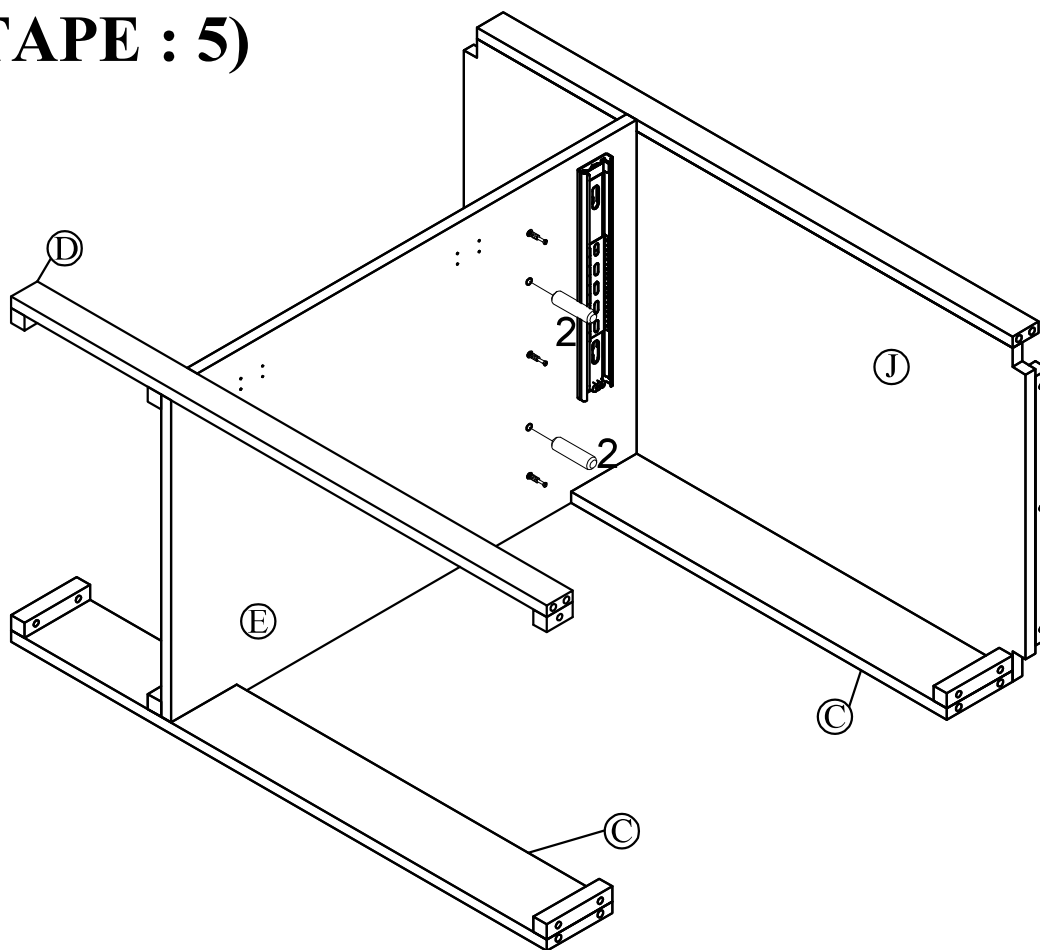

STEP: 6

(ÉTAPE : 6)

4





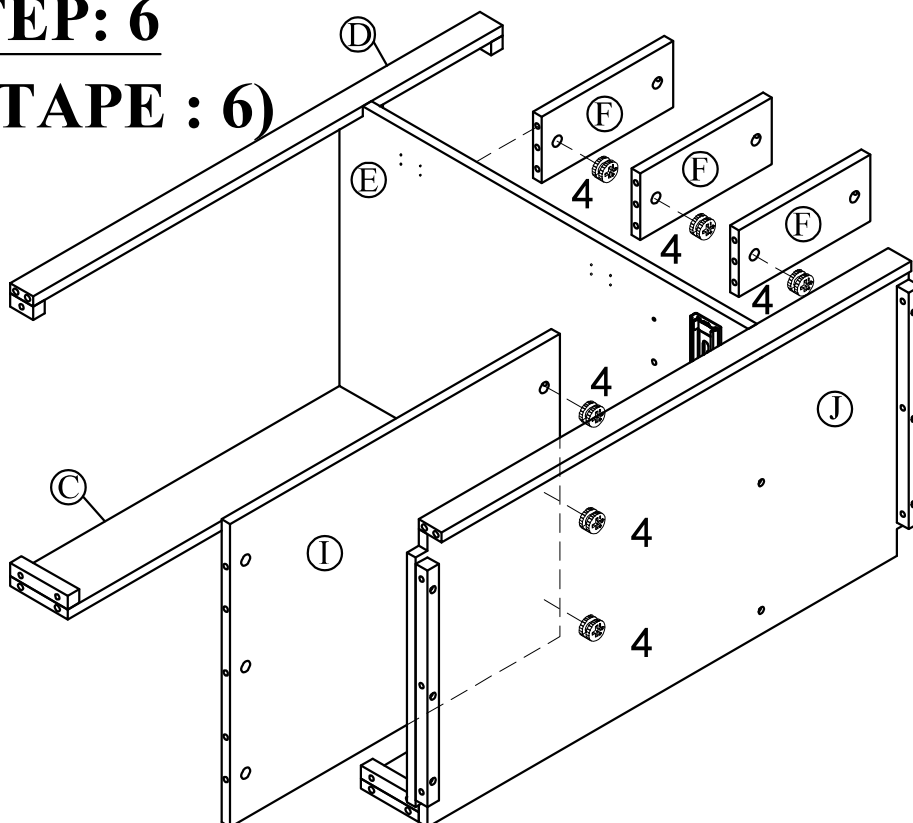

6 PCS



STEP: 7

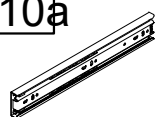

(ÉTAPE : 7)

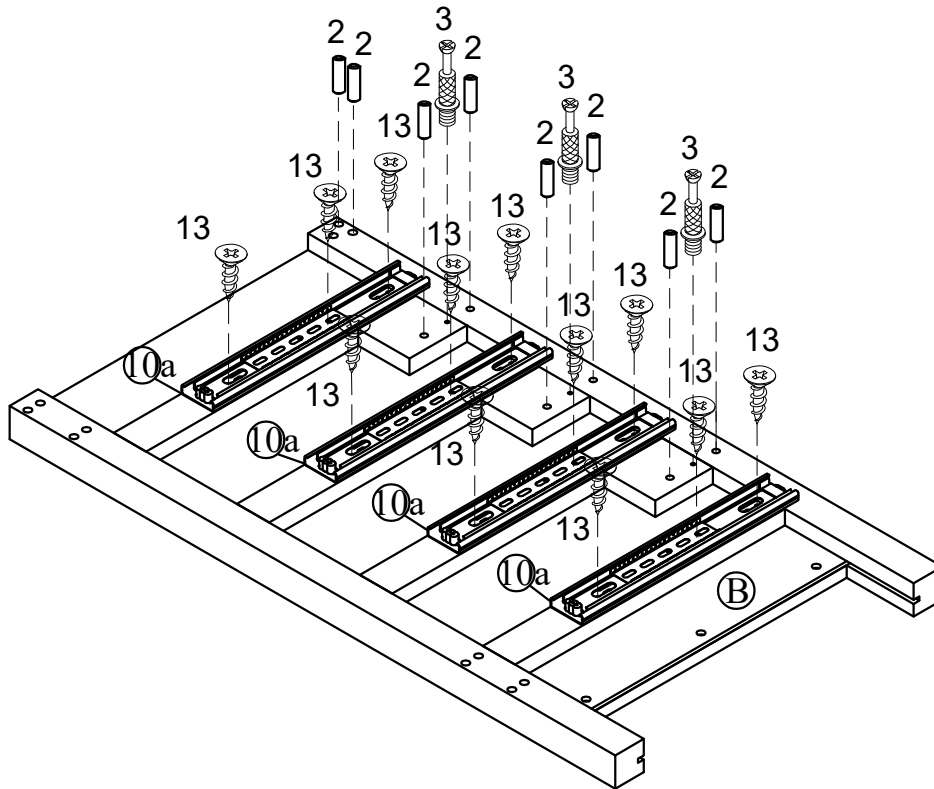
| | | | |
|---|--|--|--|
| 3 | 2 | 10a | 13 |
|  |  |  |  |
| 3 PCS | Ø8 X 30 08 PCS | 04 PCS | M3.5 X 12 12 PCS |



STEP: 7



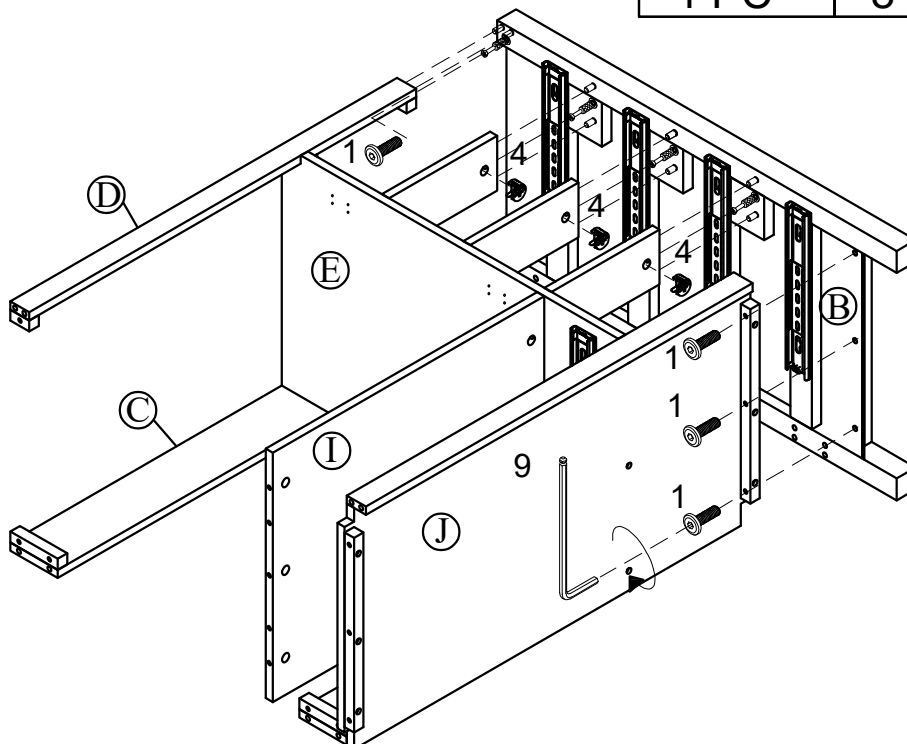

(ÉTAPE : 7)

| | | |
|--|---|---|
| 9 | 1 | 4 |
|  |  |  |
| Allen key M4 1 PC | 1/4 X 30 8 PCS | 3 PCS |



STEP: 9

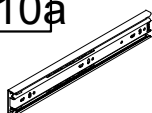

(ÉTAPE : 9)

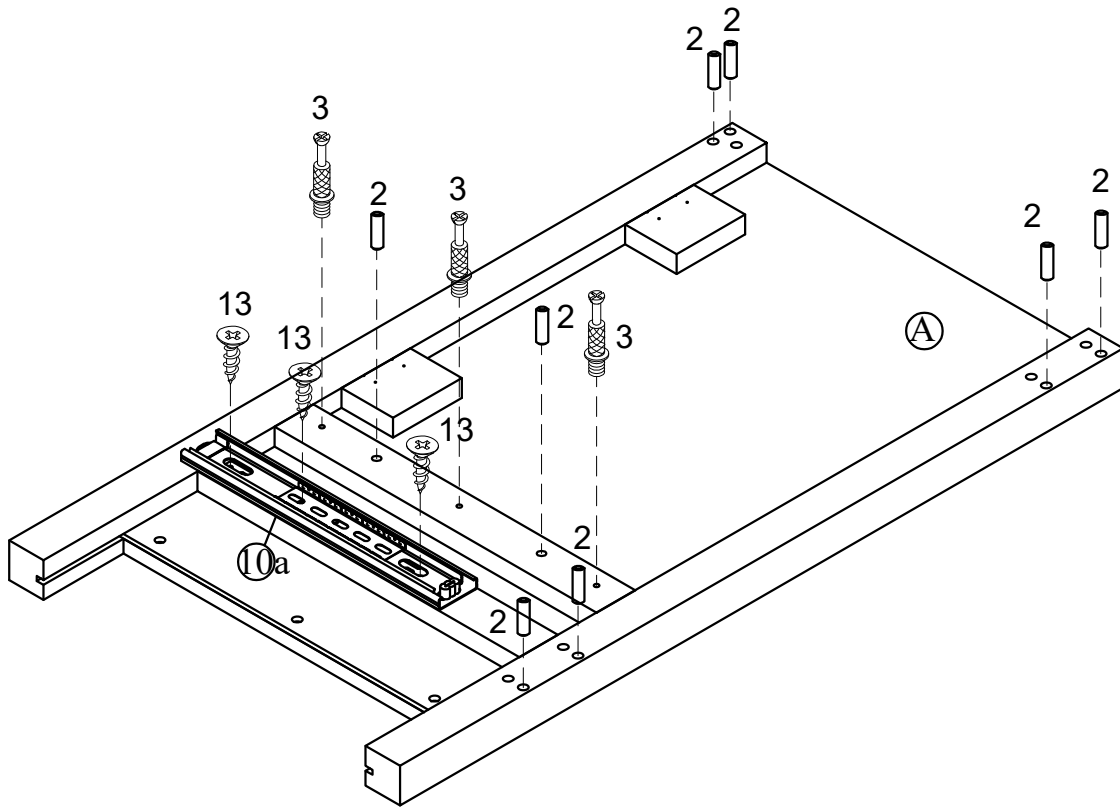
| | | | |
|---|--|--|---|
| 3 | 2 | 10a | 13 |
|  |  |  |  |
| 3 PCS | Ø8 X 30 08 PCS | 01 PC | M3.5 X 12 3 PCS |



STEP: 10

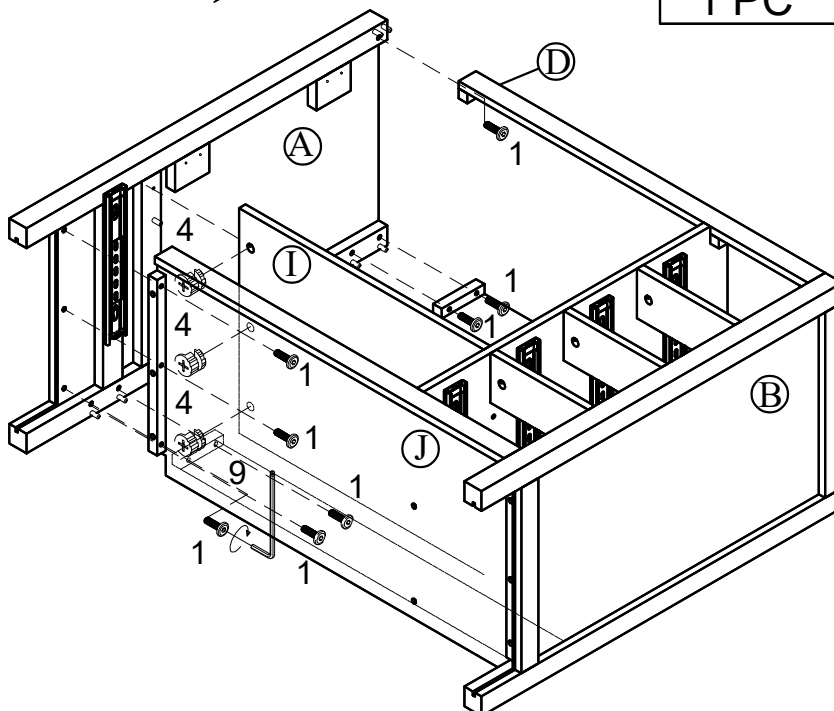

(ÉTAPE : 10)

| | | |
|--|---|---|
| 9 | 1 | 4 |
|  |  |  |
| Allen key M4 1 PC | 1/4 X 30 8 PCS | 3 PCS |



STEP: 11

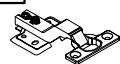

(ÉTAPE : 11)

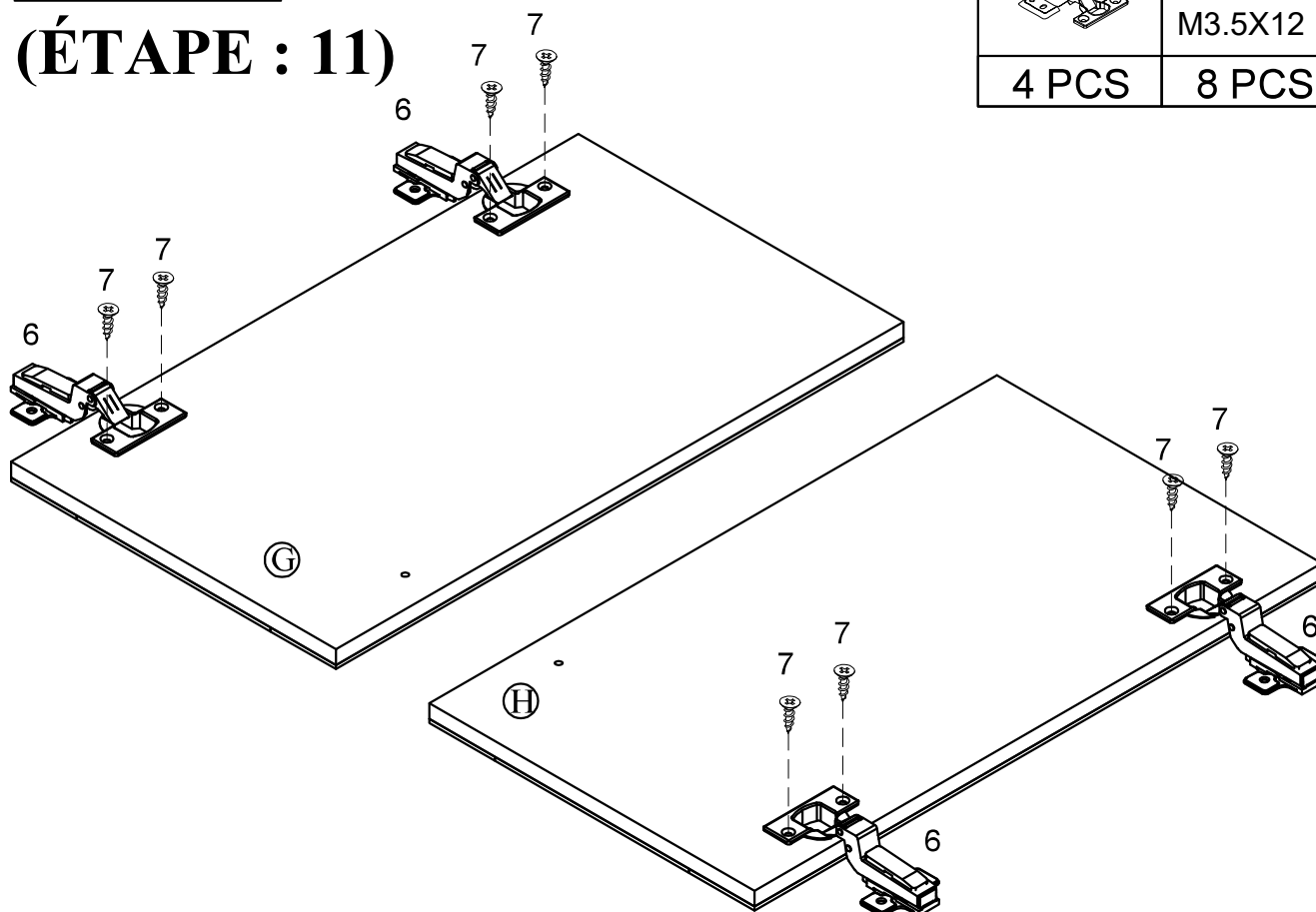
| | | | |
|-------|---|-------|--|
| 6 |  | 7 |  |
| | | | M3.5X12 |
| 4 PCS | | 8 PCS | |



STEP: 12

(ÉTAPE : 12)

| | | | |
|--------|---|--------|---|
| 10b |  | 13 |  |
| | | | M3.5 X 12 |
| 10 PCS | | 30 PCS | |

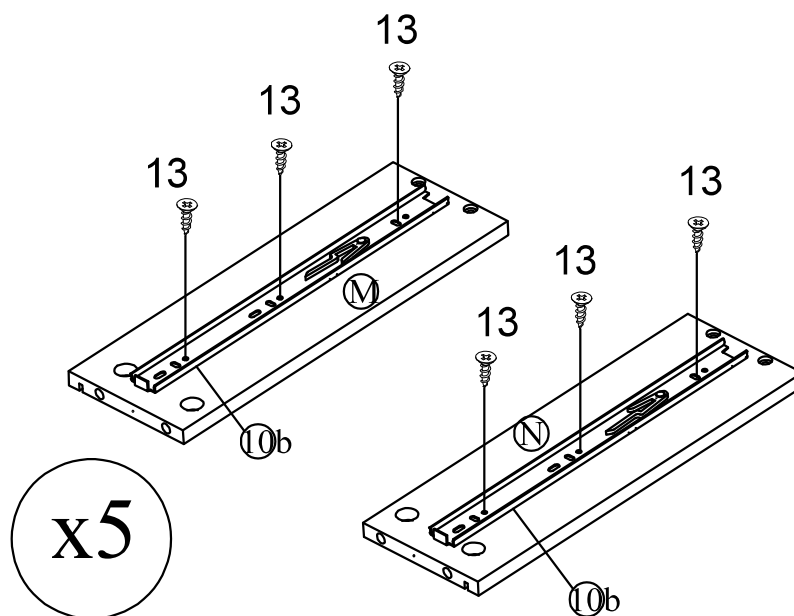

STEP: 13

(ÉTAPE : 13)

3



20 PCS

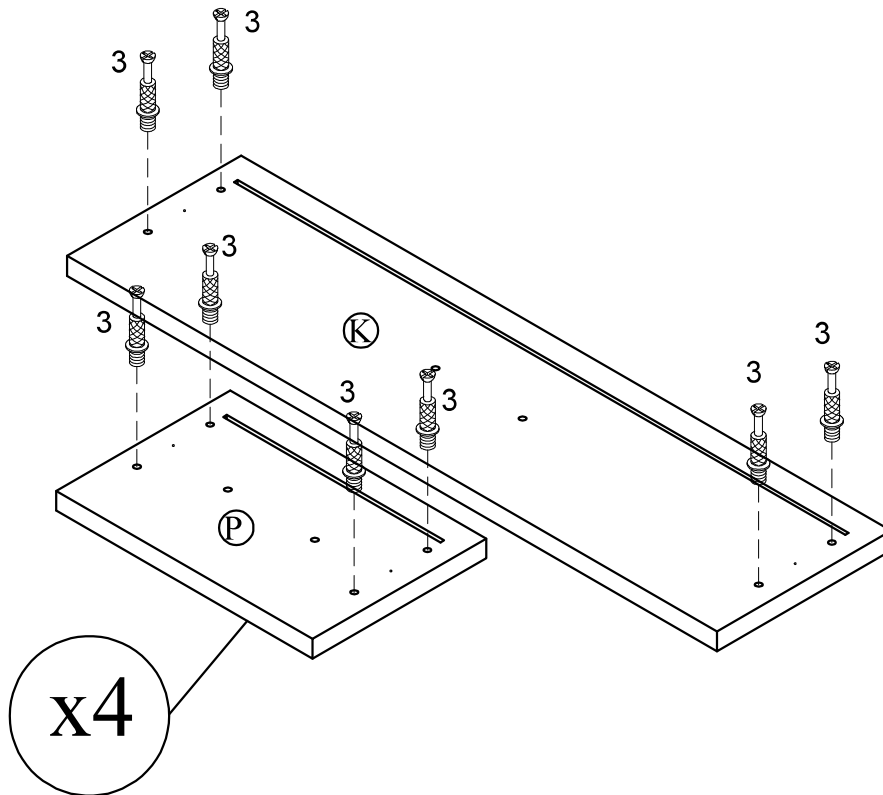

STEP: 14

(ÉTAPE : 14)

4



20 PCS

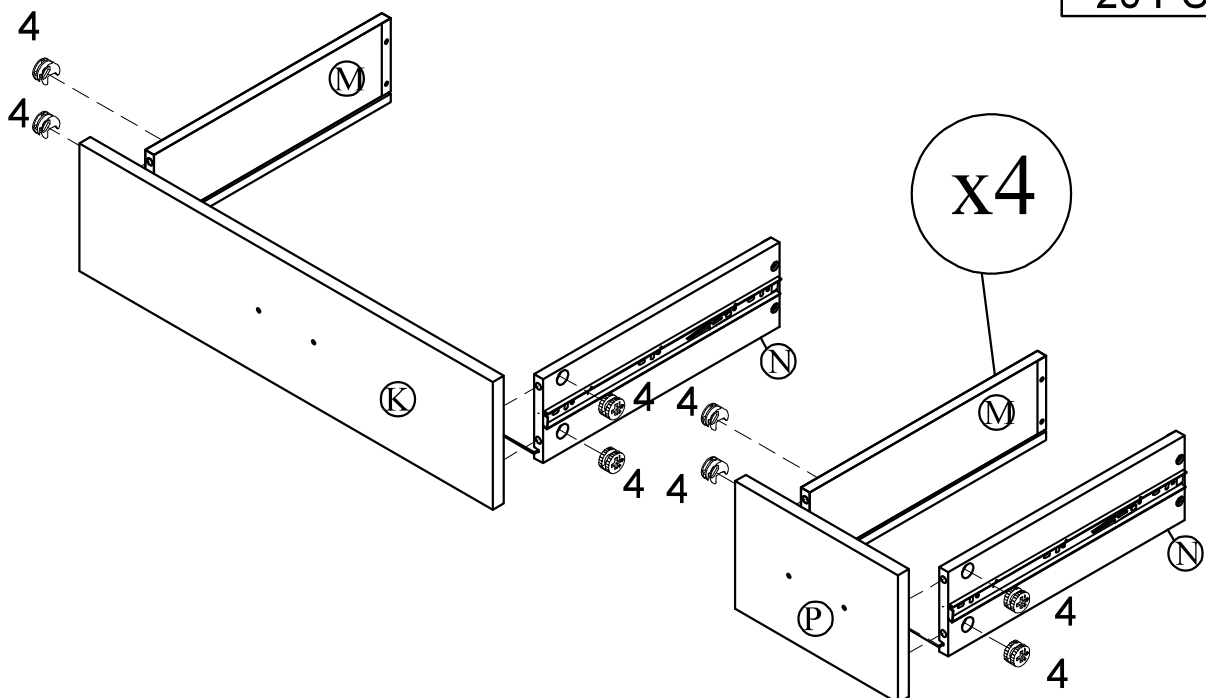

STEP: 15

(ÉTAPE : 15)

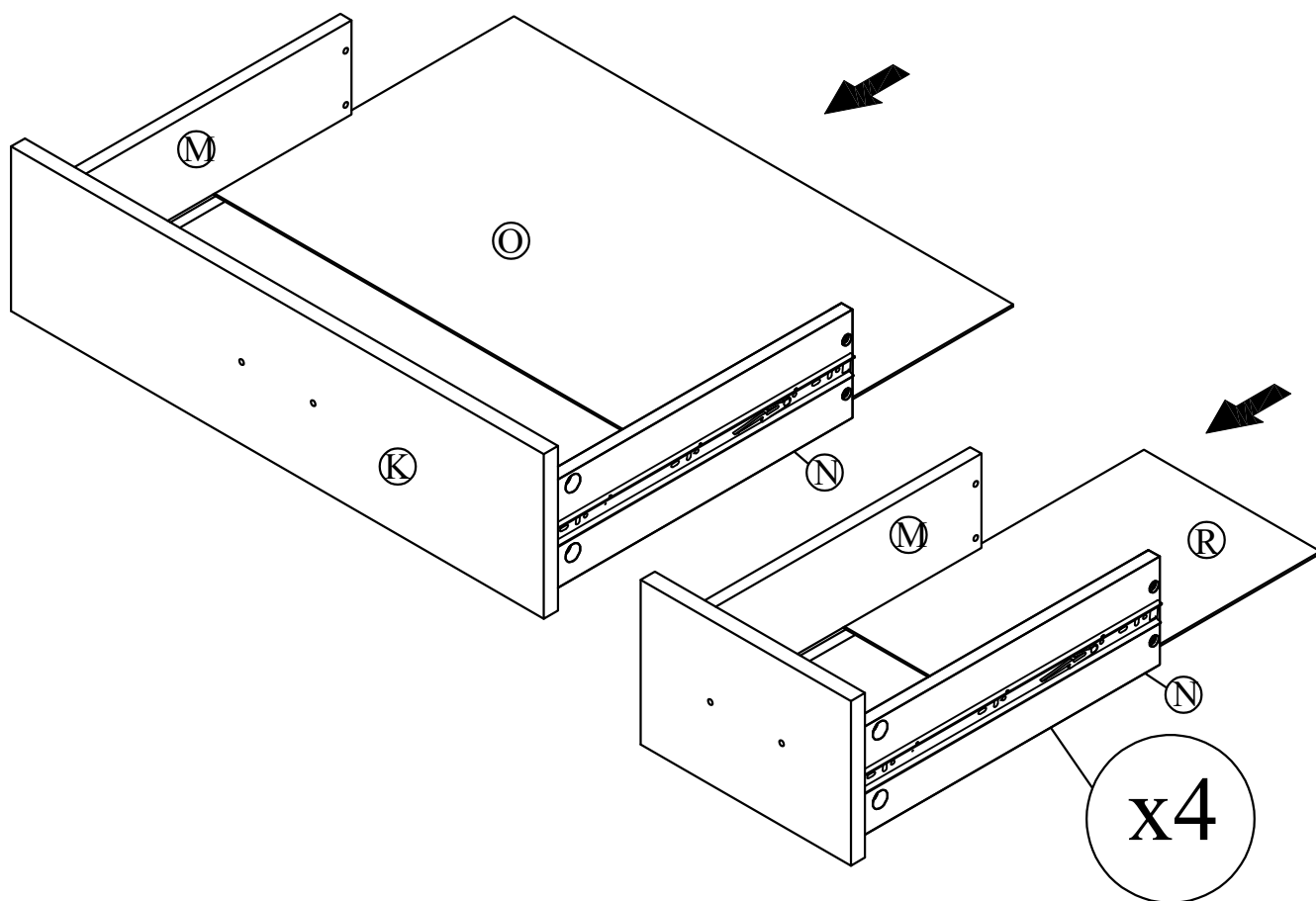

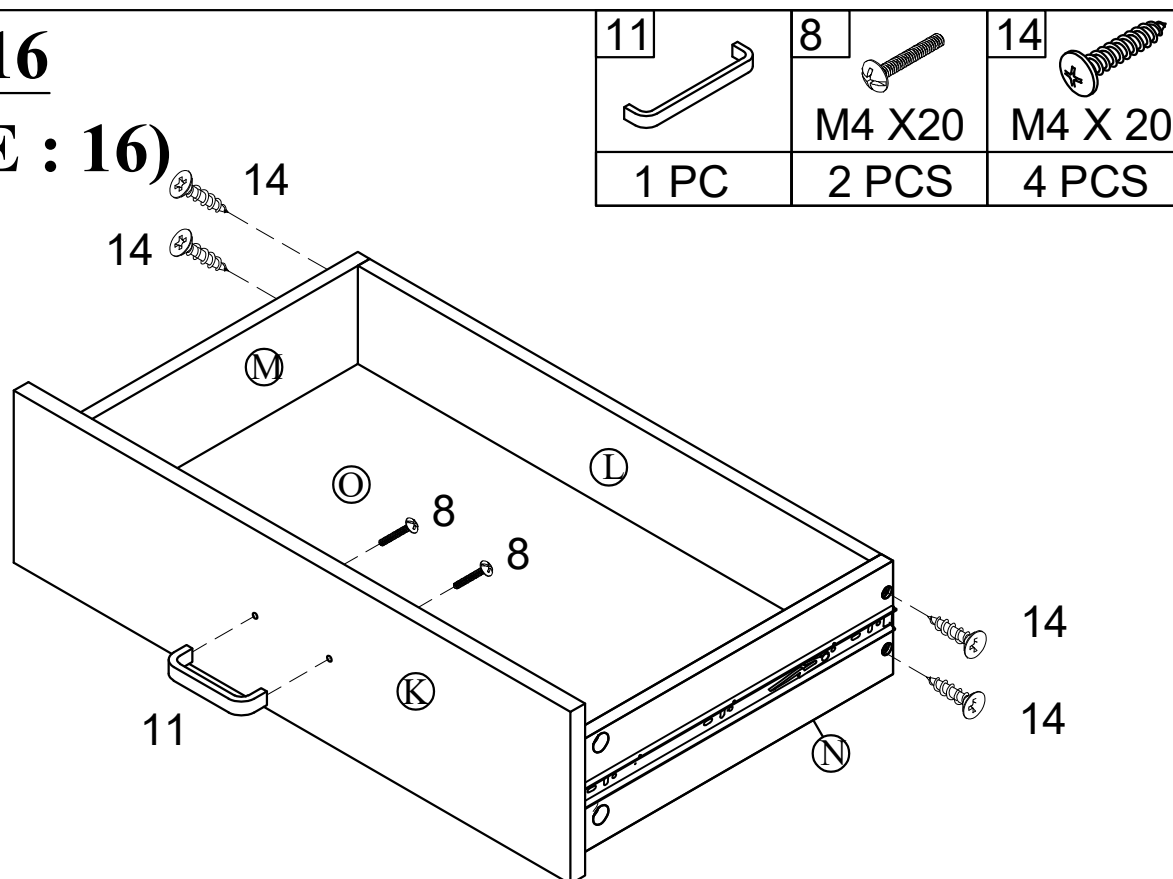

STEP: 16

(ÉTAPE : 16)



STEP: 17

(ÉTAPE : 17)

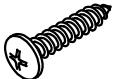
| | | | | | |
|----|---|---|--|----|--|
| 11 |  | 8 |  | 14 |  |
| | | | M4 X20 | | M4 X 20 |
| | 4 PCS | | 8 PCS | | 16 PCS |

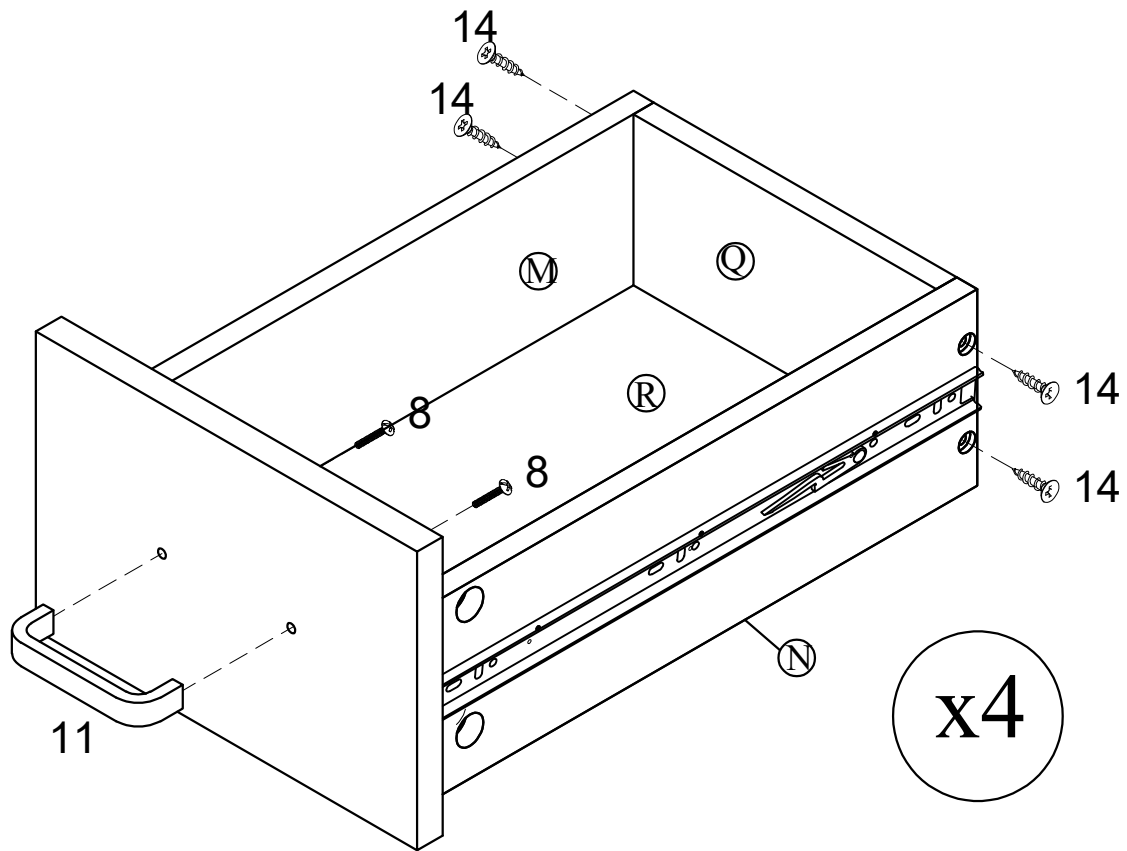

STEP: 18

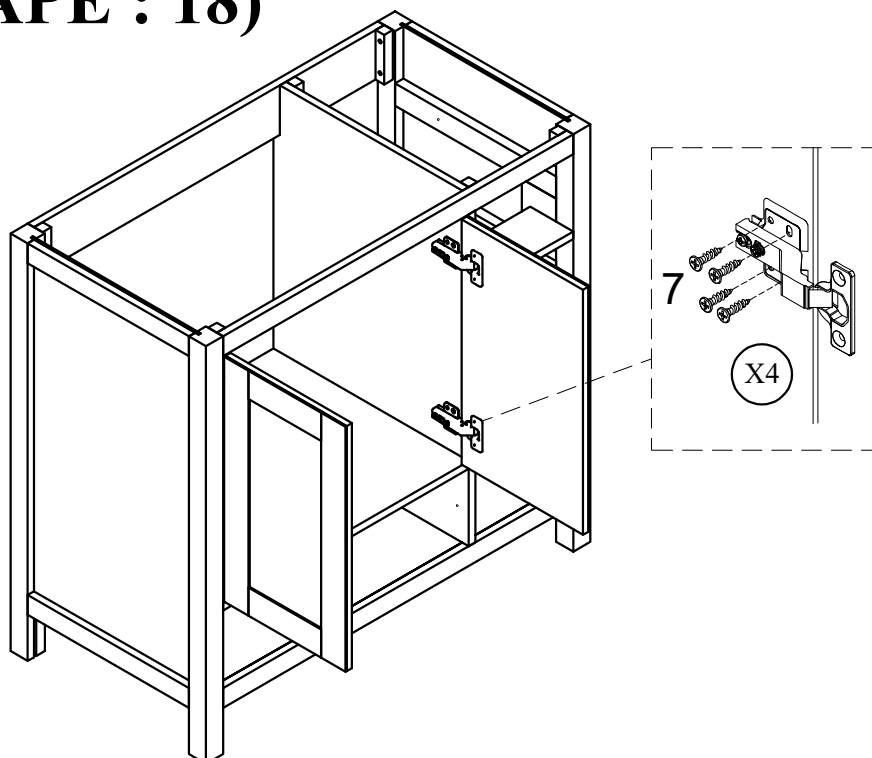

(ÉTAPE : 18)

| | |
|---|---|
| 7 |  |
| | M4 X 15 |
| | 16 PCS |



STEP: 19

(ÉTAPE : 19)

| | | | |
|-------|--|--------|--|
| 12 |  | 8 |  |
| | | M4 X20 | |
| 2 PCS | | 2 PCS | |

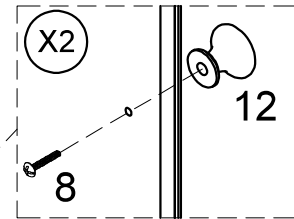
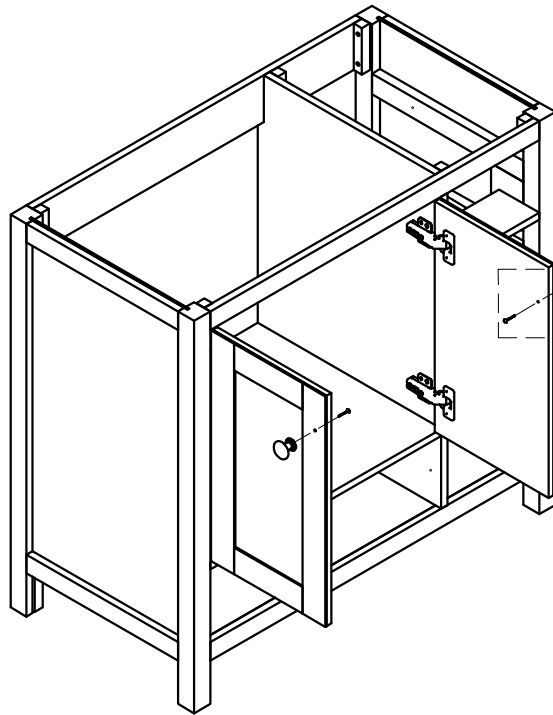

STEP: 20

(ÉTAPE : 20)

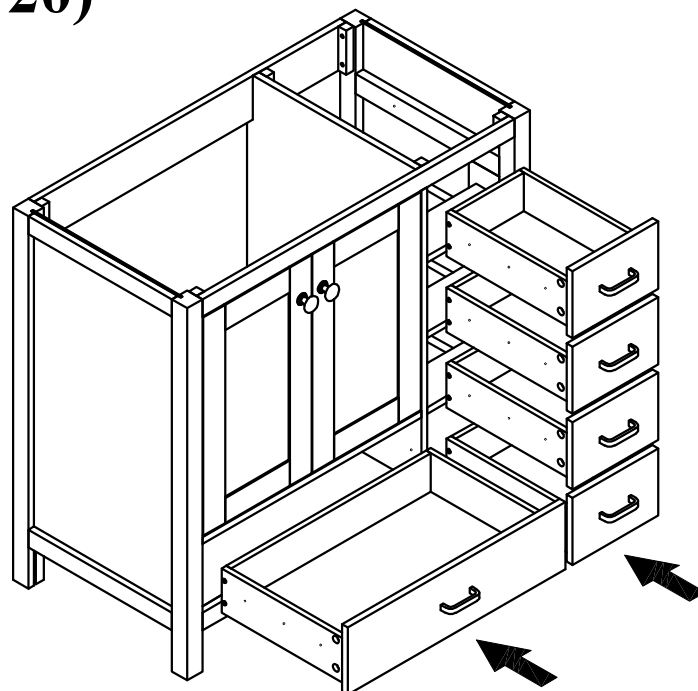

STEP: 21

(ÉTAPE : 21)

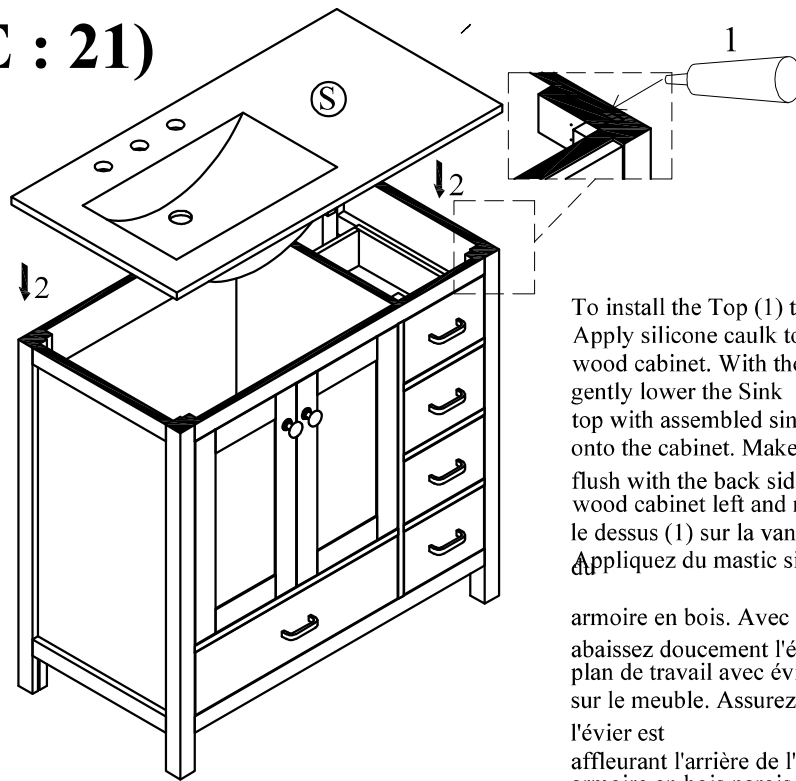

To install the Top (1) to the vanity (2). Apply silicone caulk to the top edge of the wood cabinet. With the help of another adult, gently lower the Sink top with assembled sink onto the cabinet. Make sure the Sink top is flush with the back side of the wood cabinet and the wood cabinet left and right side walls. Pour installer le dessus (1) sur la vanité (2). Appliquez du mastic silicone sur le bord supérieur



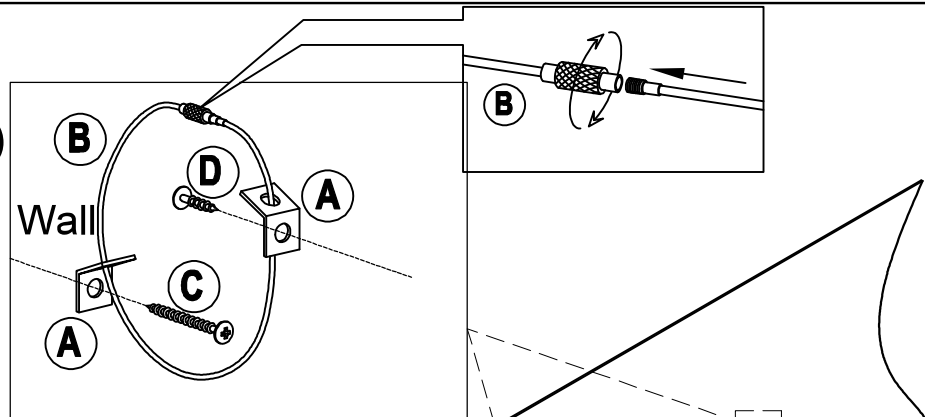

armoie en bois. Avec l'aide d'un autre adulte, abaissez doucement l'évier plan de travail avec évier assemblé sur le meuble. Assurez-vous que le dessus de l'évier est affleurant l'arrière de l'armoie en bois et le armoie en bois parois latérales gauche et droite.

STEP: 22

(ÉTAPE : 22)

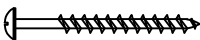
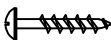

Hardware list: (Anti tipping kit 2 set in the bag)

| | |
|--|---|
| <p>A</p>  <p>Brackets - 04pcs</p> | <p>B</p>  <p>Steel cables - 02pcs</p> |
| <p>C</p>  <p>Screws - 02pcs</p> | <p>D</p>  <p>Screws - 02pcs</p> |
| <p>E</p>  <p>wall anchor - 02pcs</p> | |

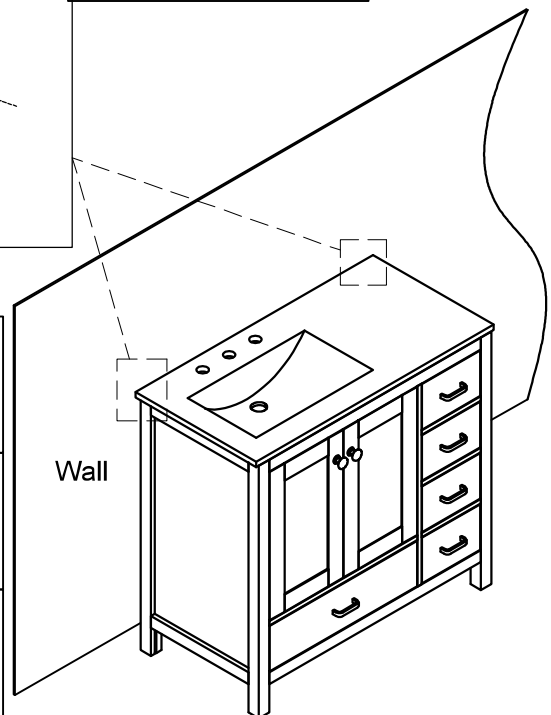

HINGE ADJUSTMENTS

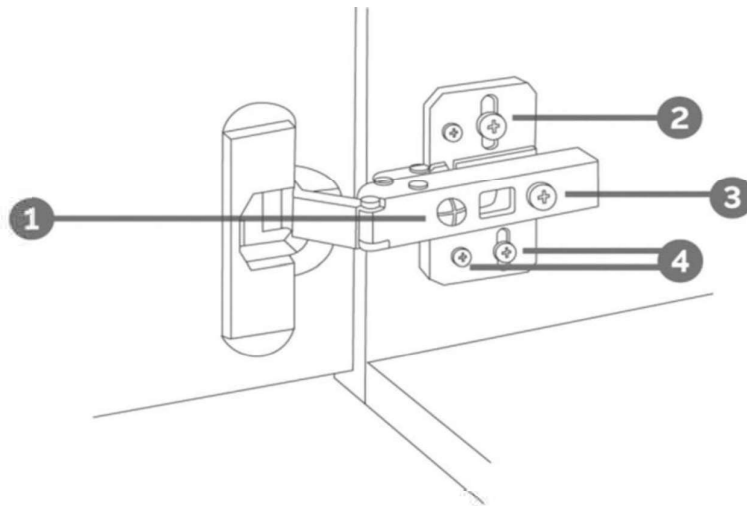

1 Sideways / Tilt adjustment

Turn the screw
clockwise to move the door further away from the side of the cabinet
anticlockwise to move the door closer to the side of the cabinet

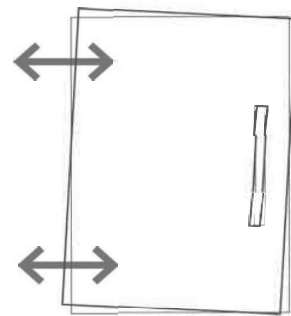

2 4 Height adjustment

While supporting the weight of the door, turn the screws
clockwise to move the door up
anticlockwise to move the door down

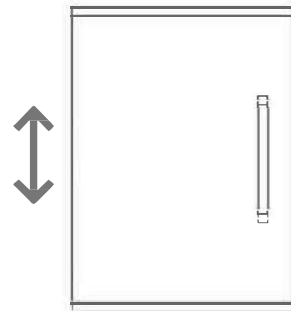

3 Forward and back adjustment

If the gap between the back of the door and the cabinet is too small, and the door may not close fully. Turn the screw
clockwise to decrease the gap between the door and the cabinet
anticlockwise to increase the gap between the door and the cabinet

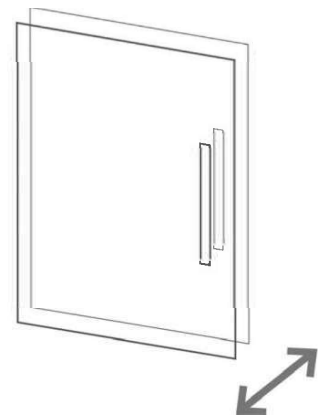

RÉGLAGES DES CHARNIÈRES

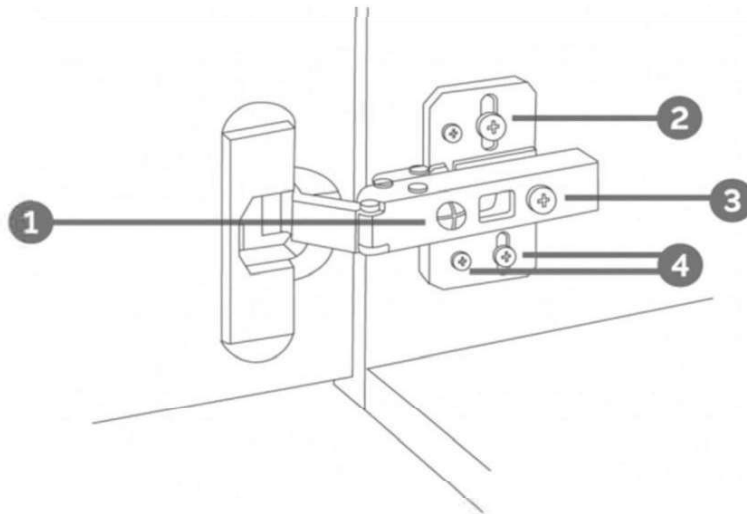

❶ De côté / Réglage de l'inclinaison

Tournez la vis
dans le sens des aiguilles d'une montre pour éloigner
la porte
le côté du meuble
dans le sens inverse des aiguilles d'une montre pour
rapprocher la porte du
côté du meuble

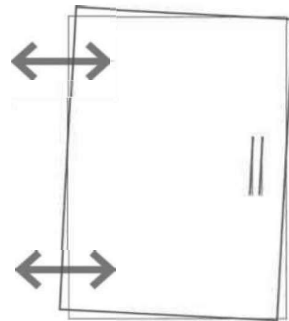

❷❹ Réglage de la

Tout en supportant le poids de la porte, tournez les vis
dans le sens des aiguilles d'une montre pour déplacer la
porte vers le haut
dans le sens inverse des aiguilles d'une montre pour
abaisser la porte

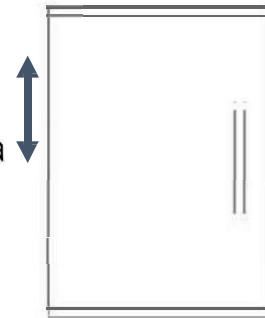

❸ Réglage vers l'avant et vers l'arrière

Si l'espace entre l'arrière de la porte et le
l'armoire est trop petite et la porte risque de ne pas se
fermer complètement. Tournez la vis
dans le sens des aiguilles d'une montre pour diminuer
l'écart entre la porte et l'armoire
dans le sens inverse des aiguilles d'une montre pour
augmenter l'écart entre la porte et l'armoire.

