

Assembly | Asambla | Assemblage

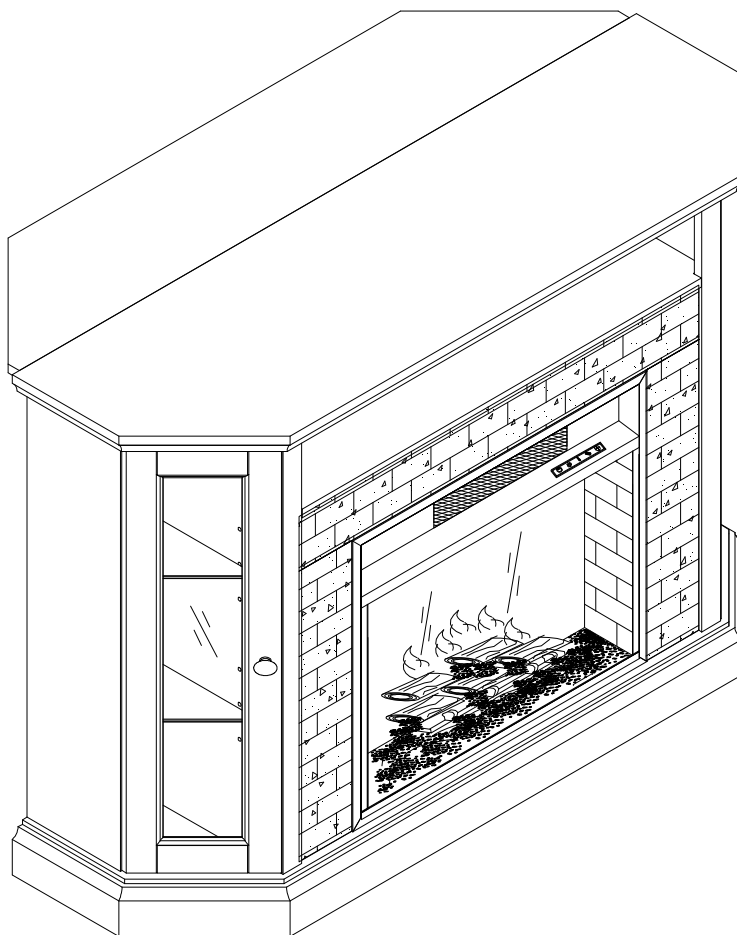

Thanks!

Thank you for your purchase. Our products offer a limited 1-year warranty and feature the latest trends and design styles.

¡Gracias!

Gracias por su compra. Nuestros productos vienen con una garantía limitada de 1 año y le ofrecen lo último en tendencias y estilos.

Merci!

Merci de votre achat. Nos produits sont offerts avec une garantie limitée de 1 an et proposent les plus récents styles et tendances en matière de conception.

Assembly | Asamlea | Assemblage

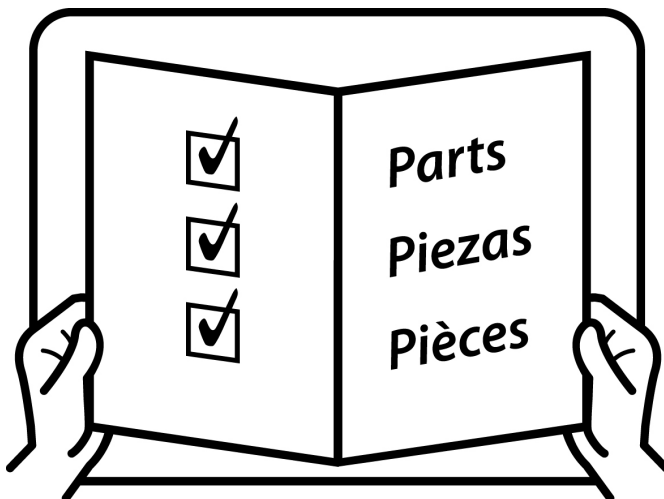
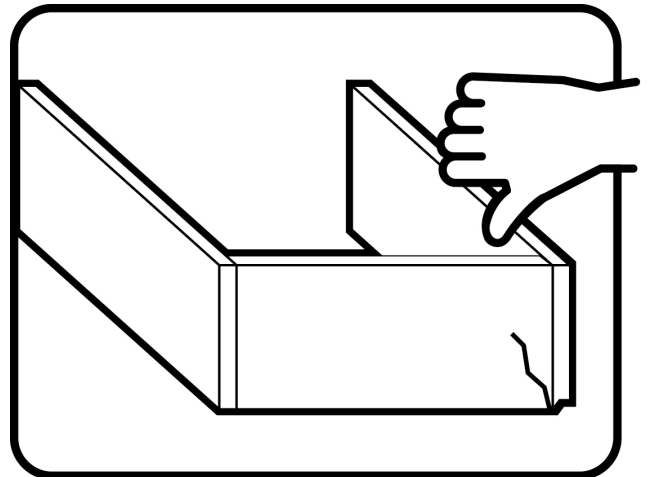
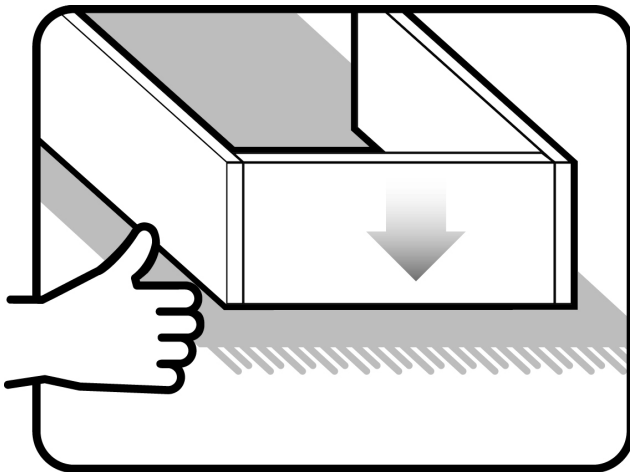
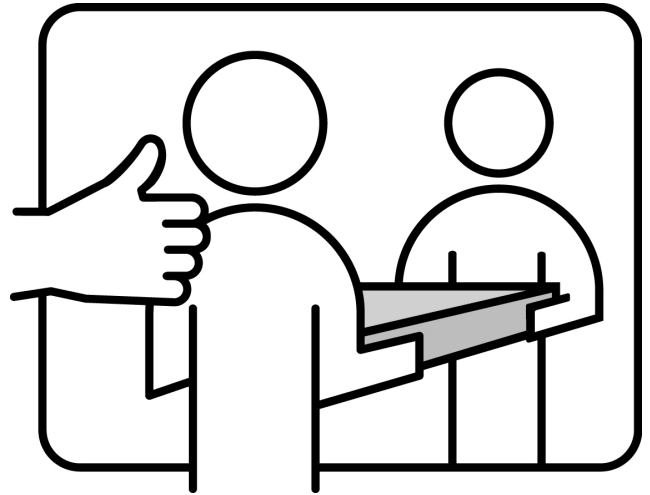
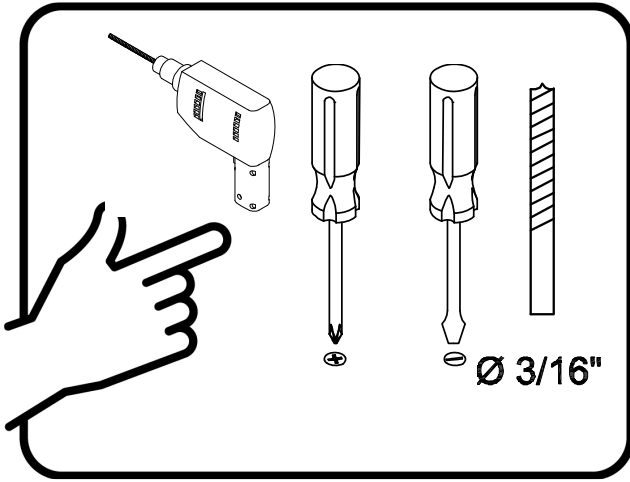

Assembly | Asamblea | Assemblage

Techniques | Técnicas | Techniques

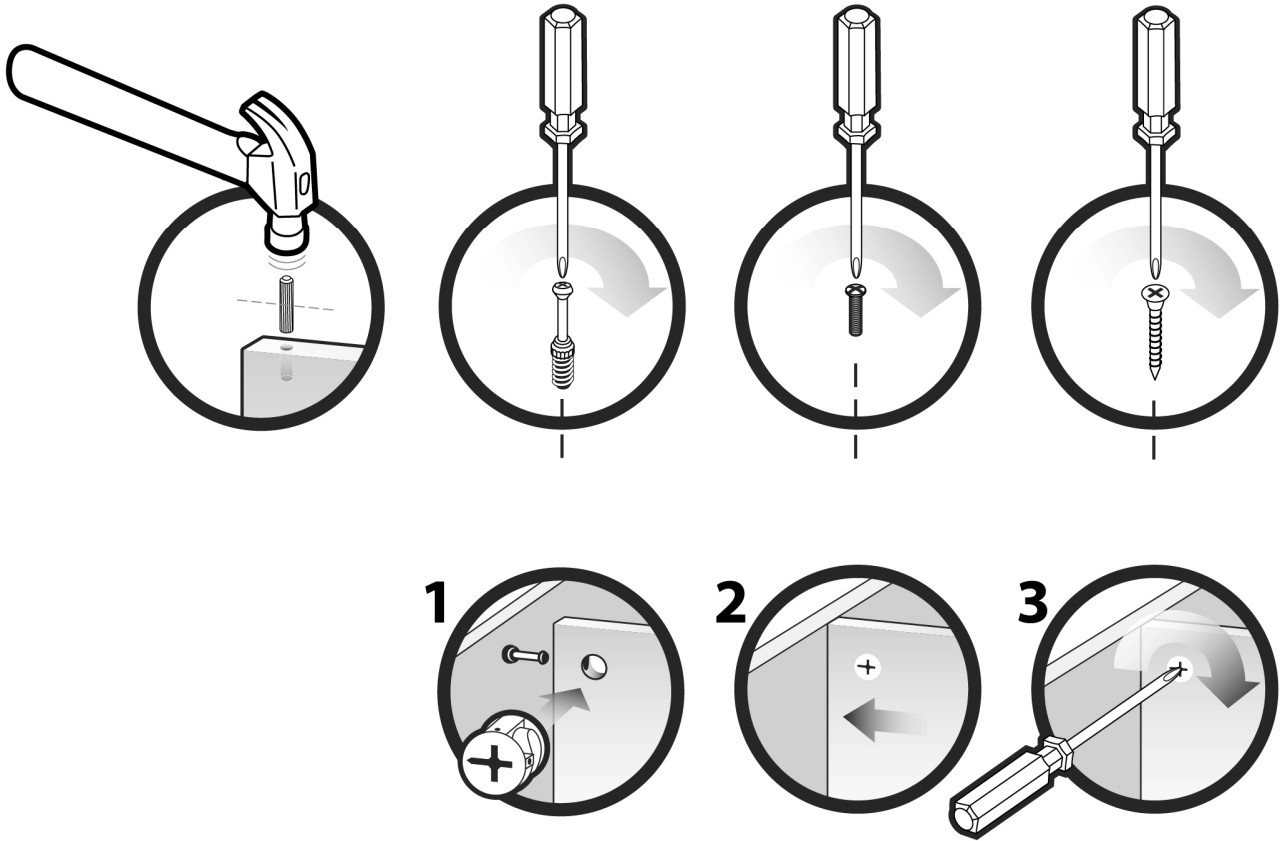

Care | Cuidado | Entretien



Assembly | Asamblea | Assemblage

Assembly Help | Ayuda para el armado | Aide à l'assemblage

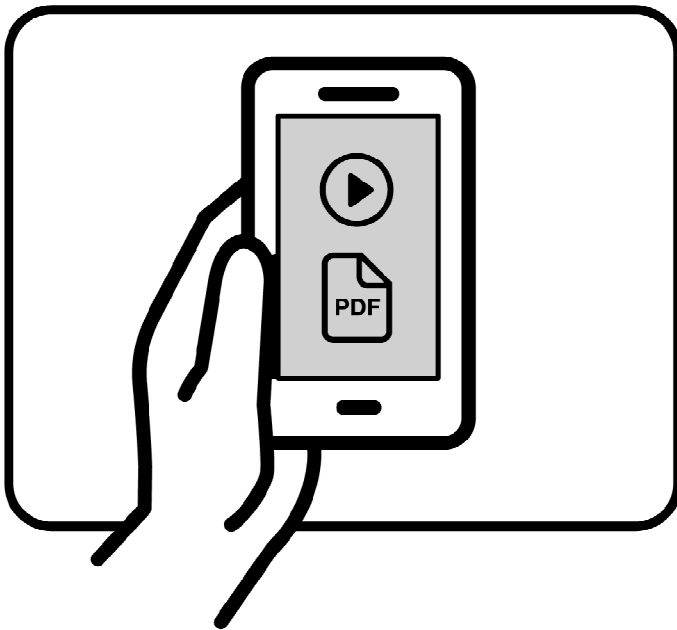
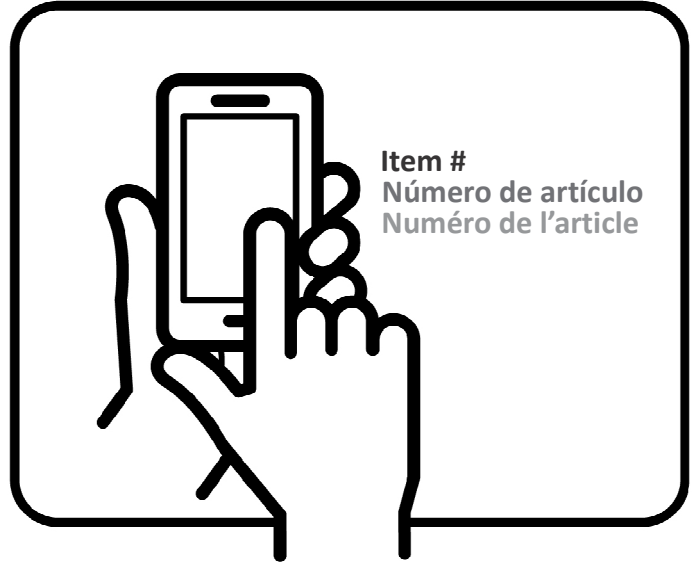
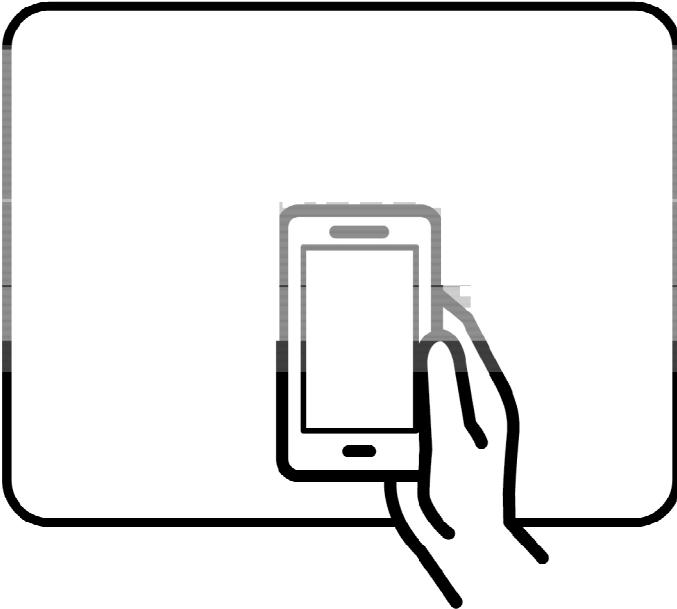

Safety | Seguridad | Sécurité



Note! | Nota: | Remarque!



5

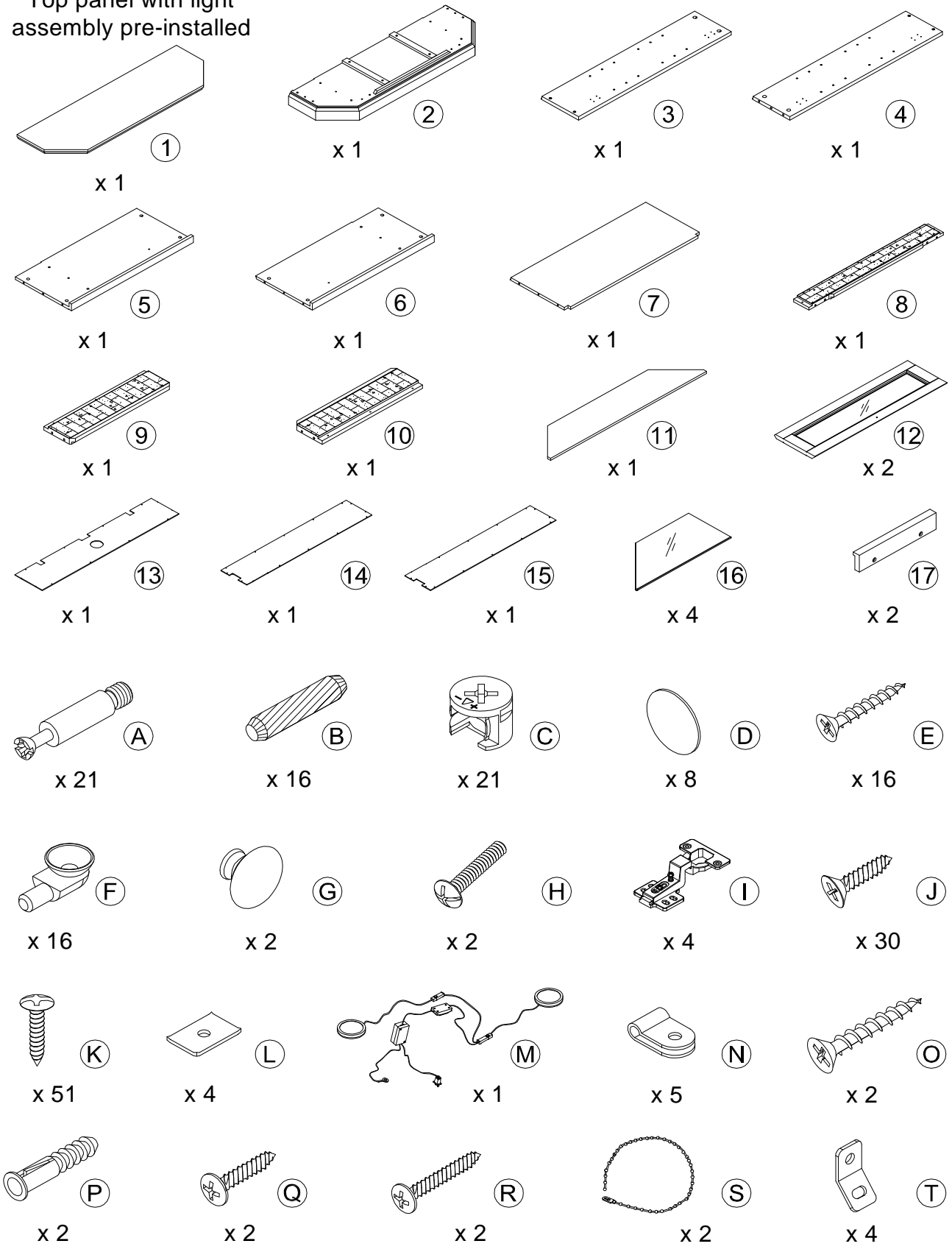

Top panel with light assembly pre-installed

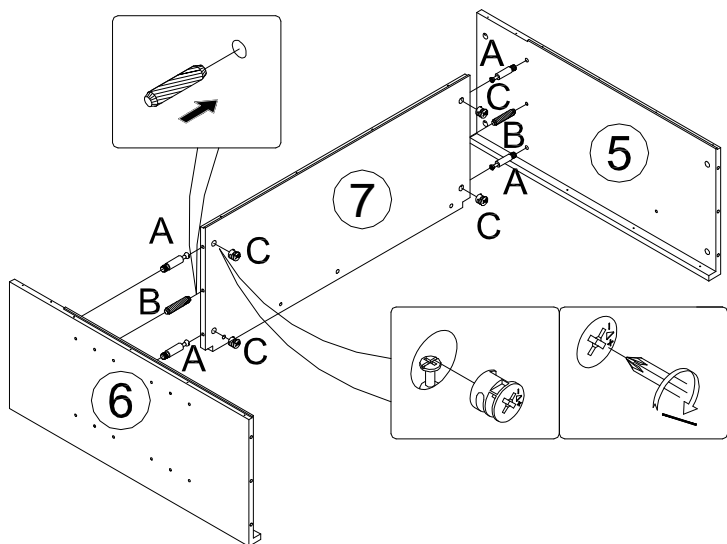

6

1



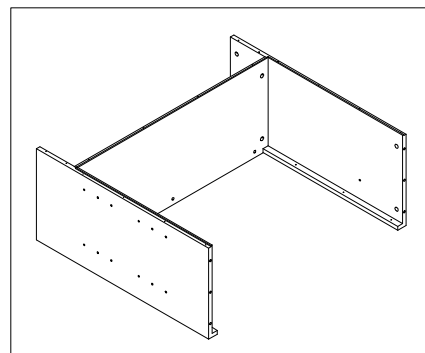

A		x 4
B		x 2
C		x 4

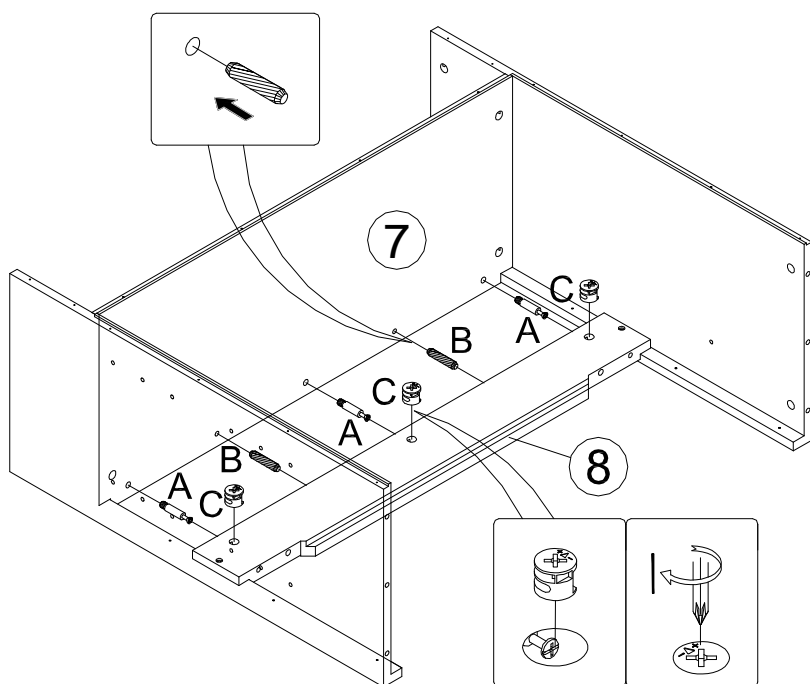

2

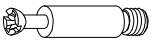



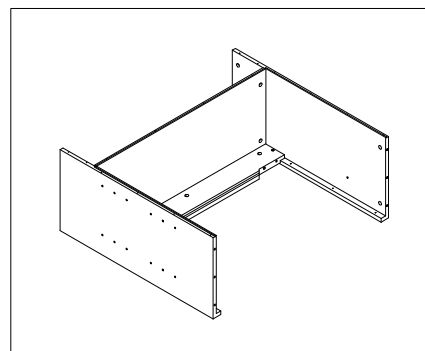

A		x 3
B		x 2
C		x 3

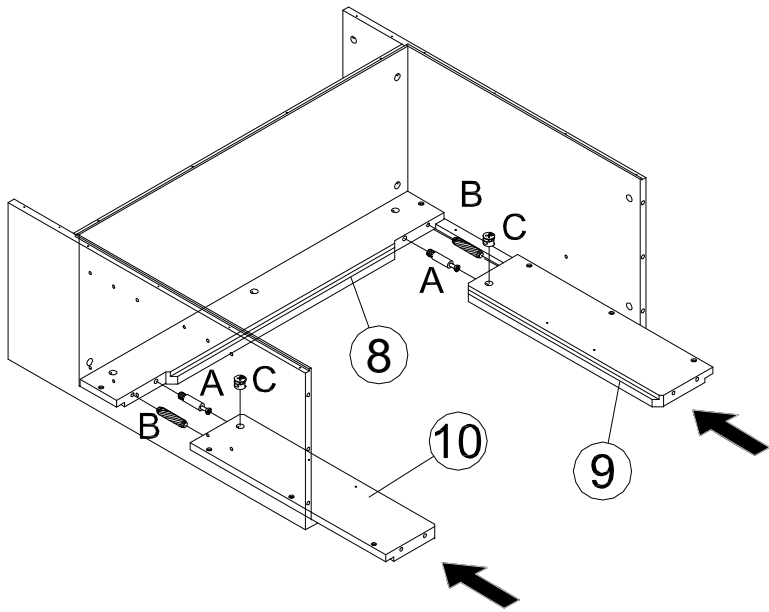

7

3



A		x 2
B		x 2
C		x 2

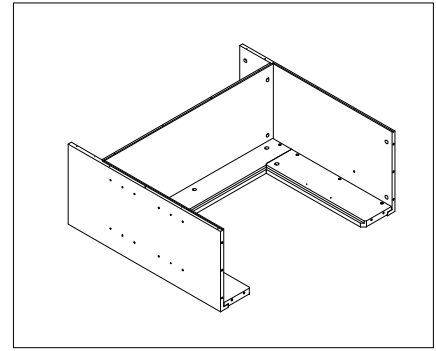

4

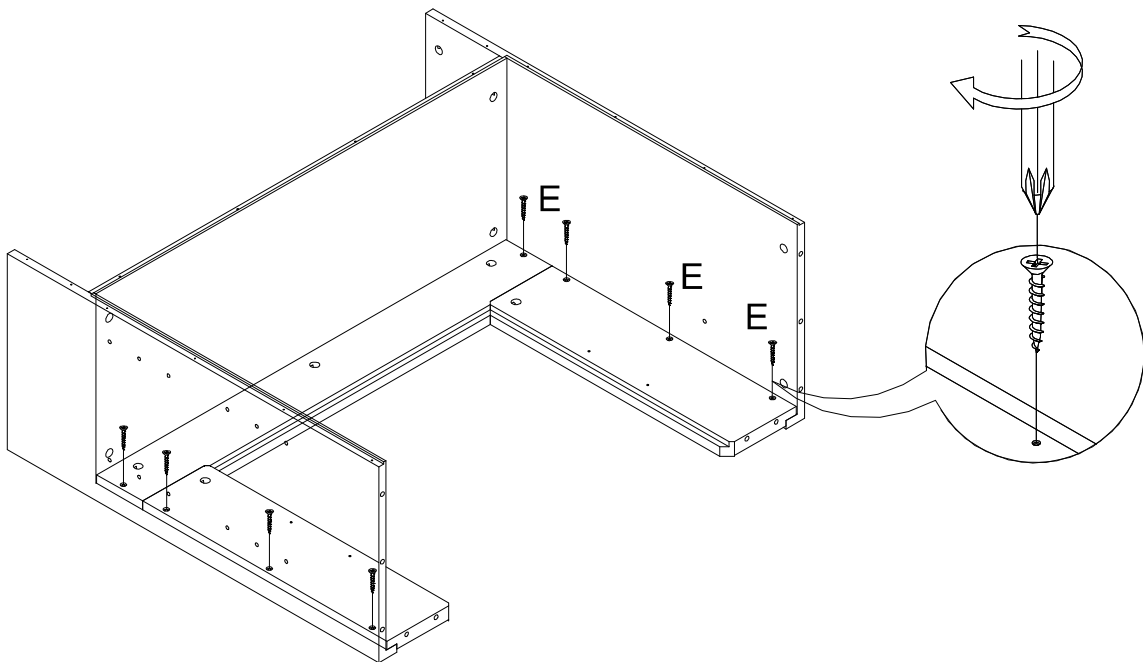

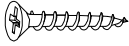

E		x 8
---	---	-----

8

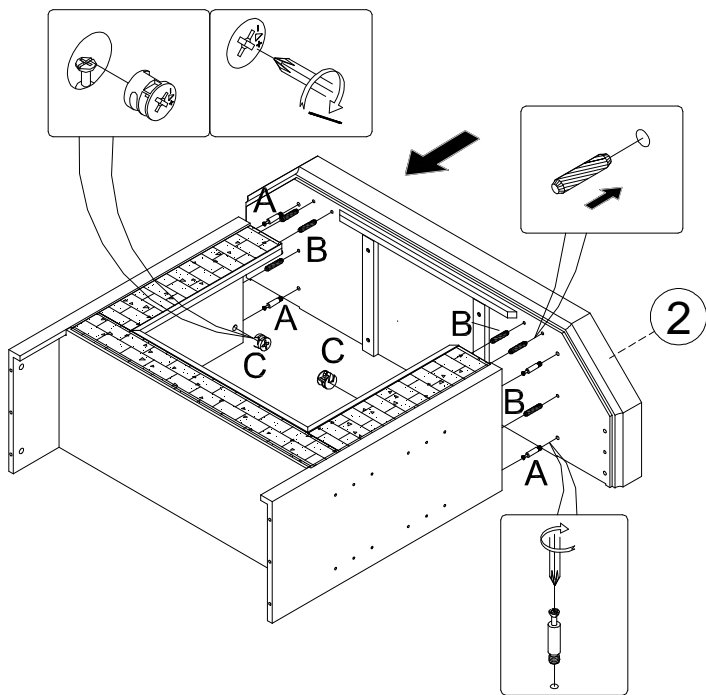
5

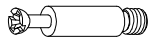

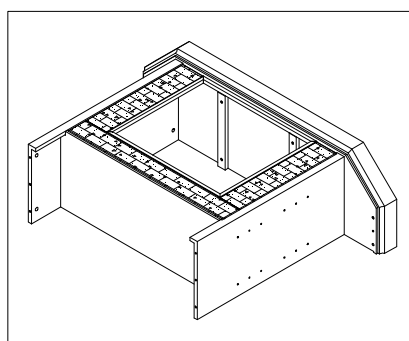

A		x 4
B		x 6
C		x 4

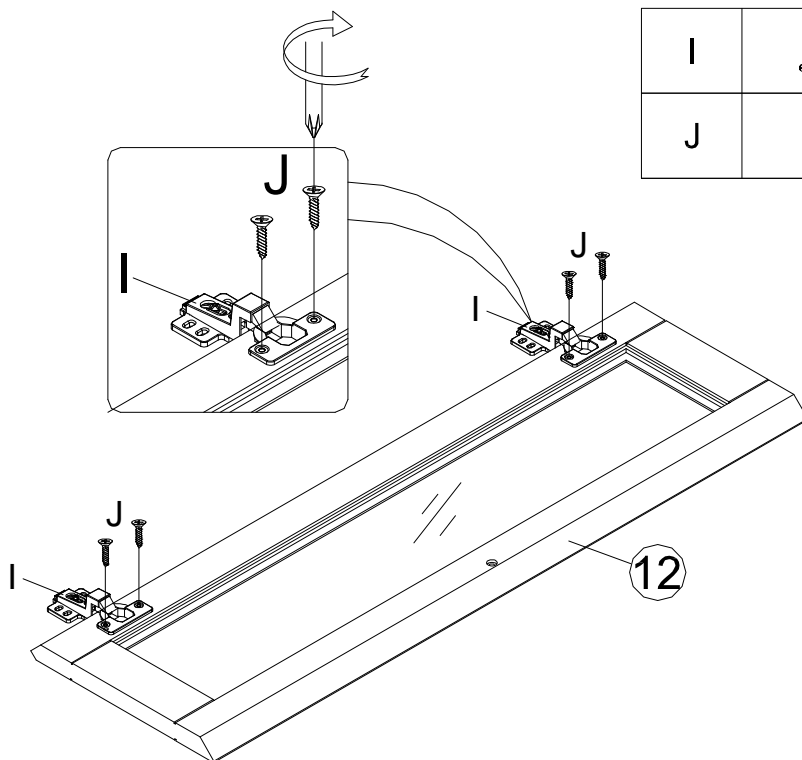

6



I		x 4
J		x 8

9

7

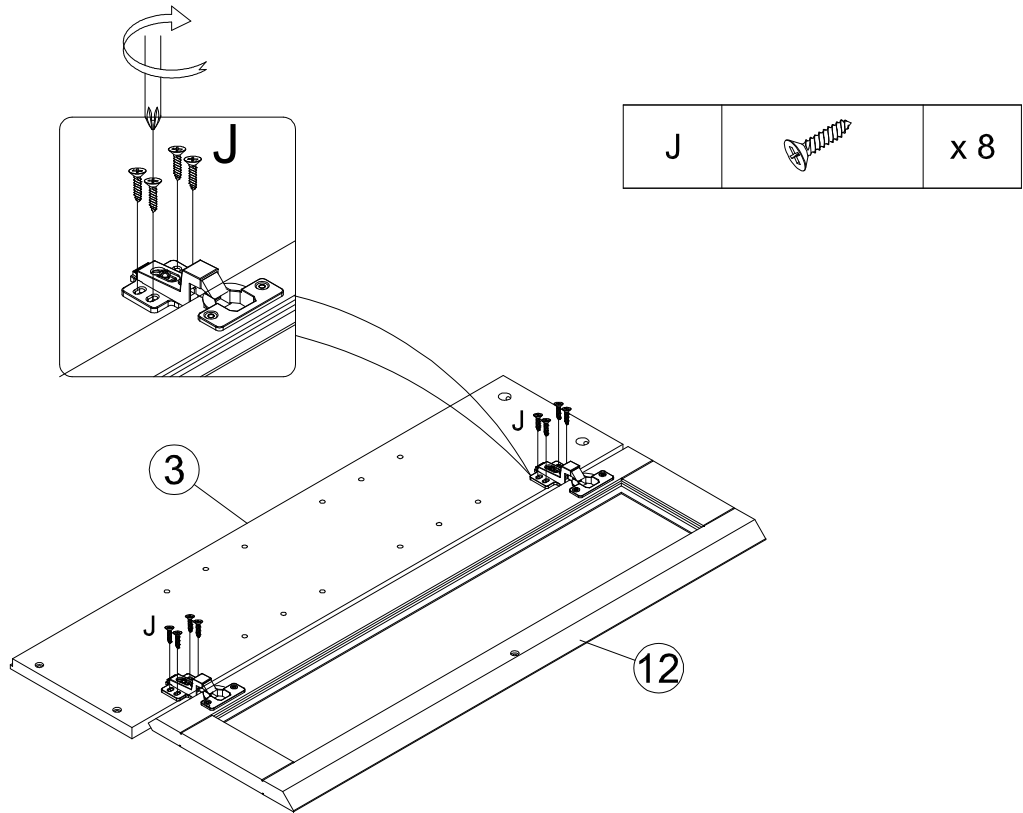



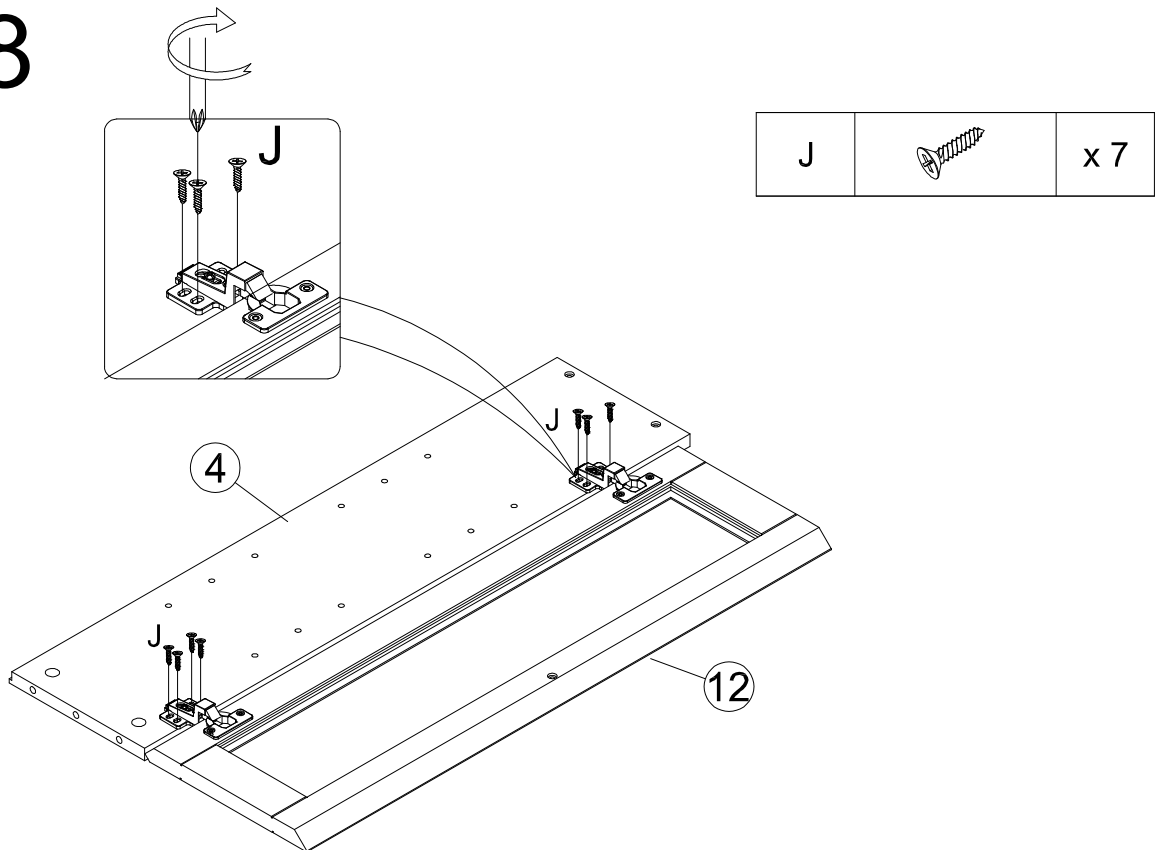

8

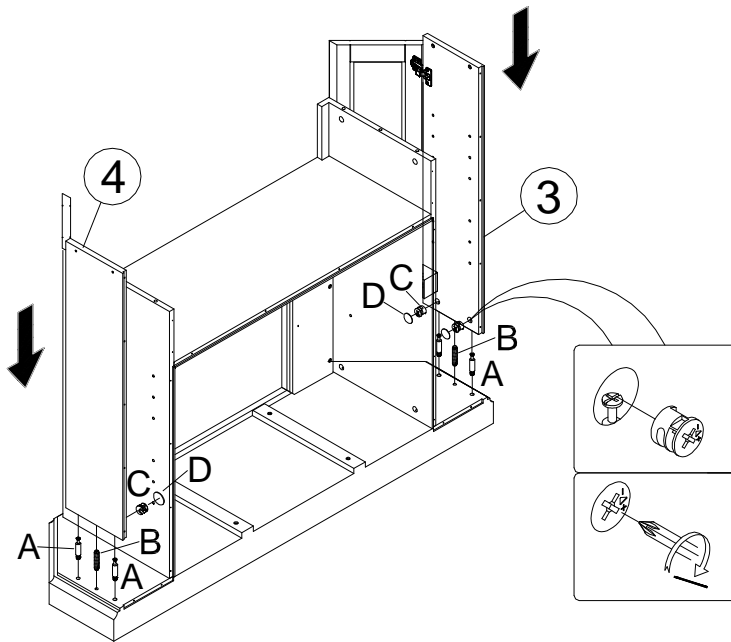

10

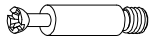
9





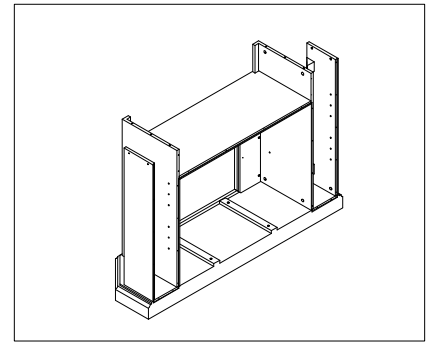

A		x 4
B		x 2
C		x 4
D		x 4

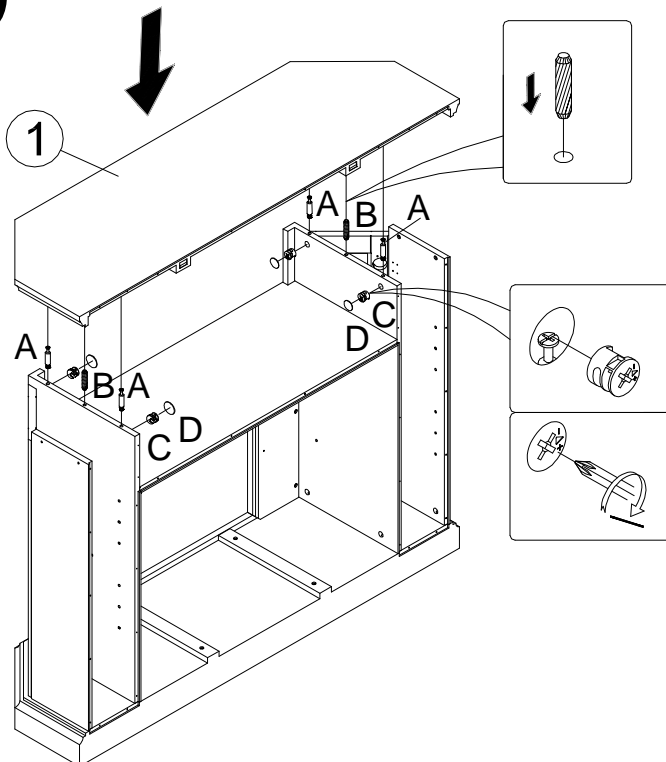

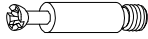
10



A		x 4
B		x 2
C		x 4
D		x 4

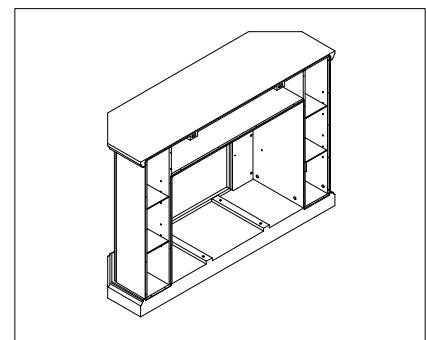

11

11

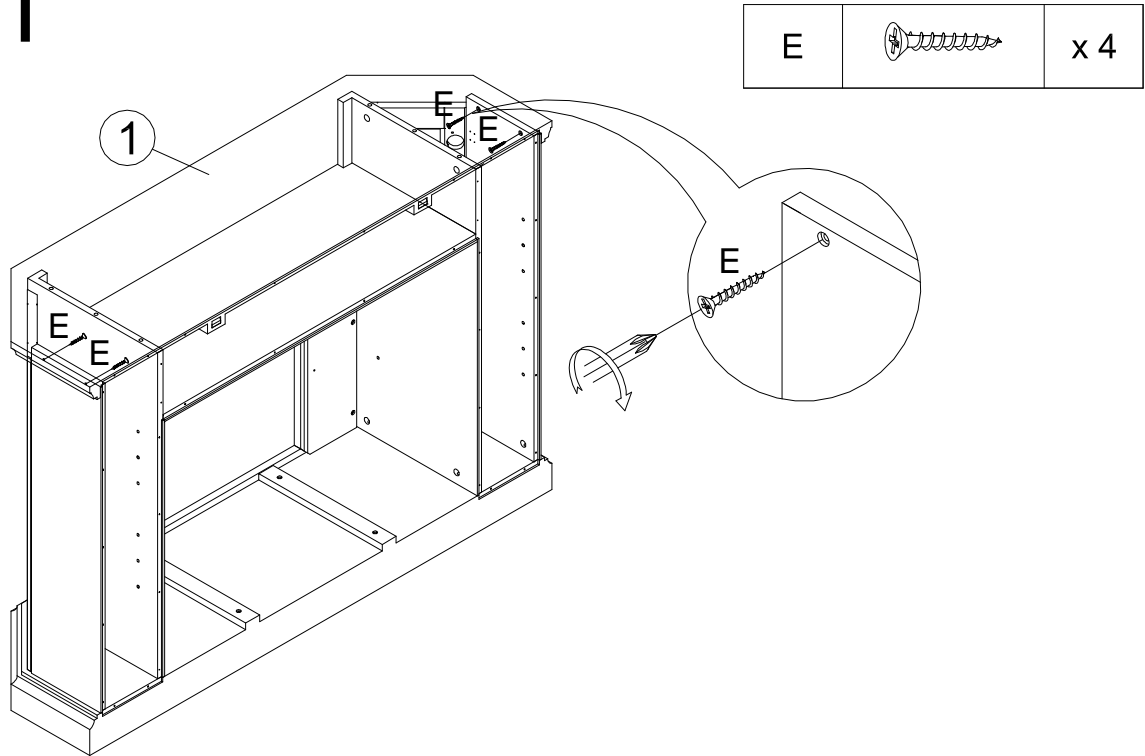

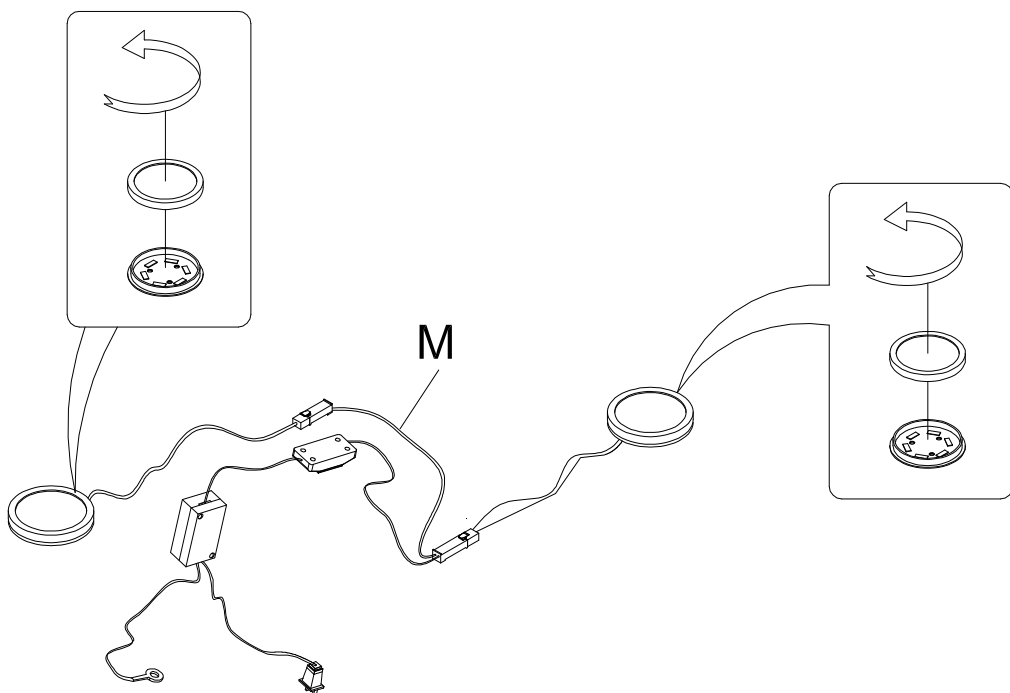

12



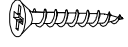

12

13

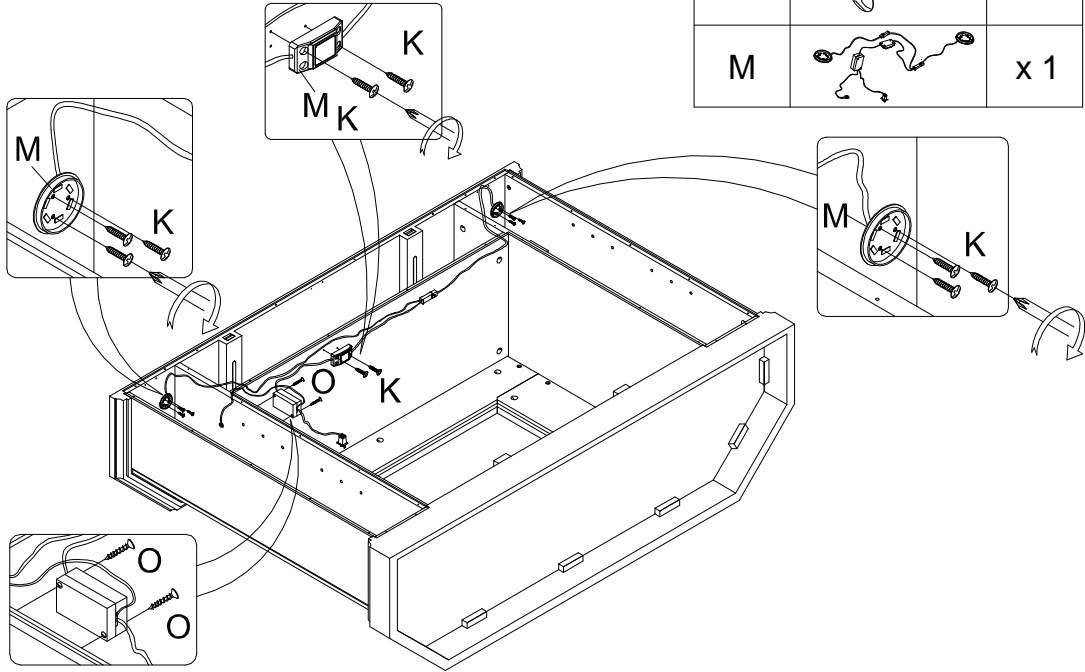
O		x 2
K		x 8
M		x 1



14

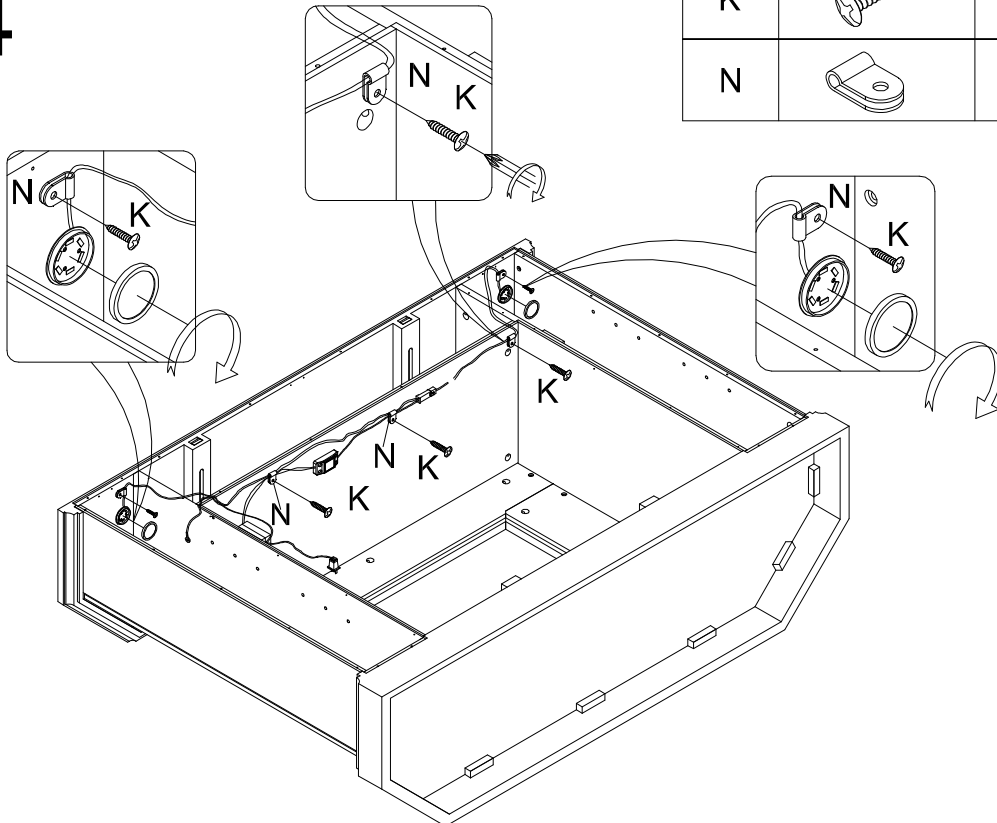

K		x 5
N		x 5

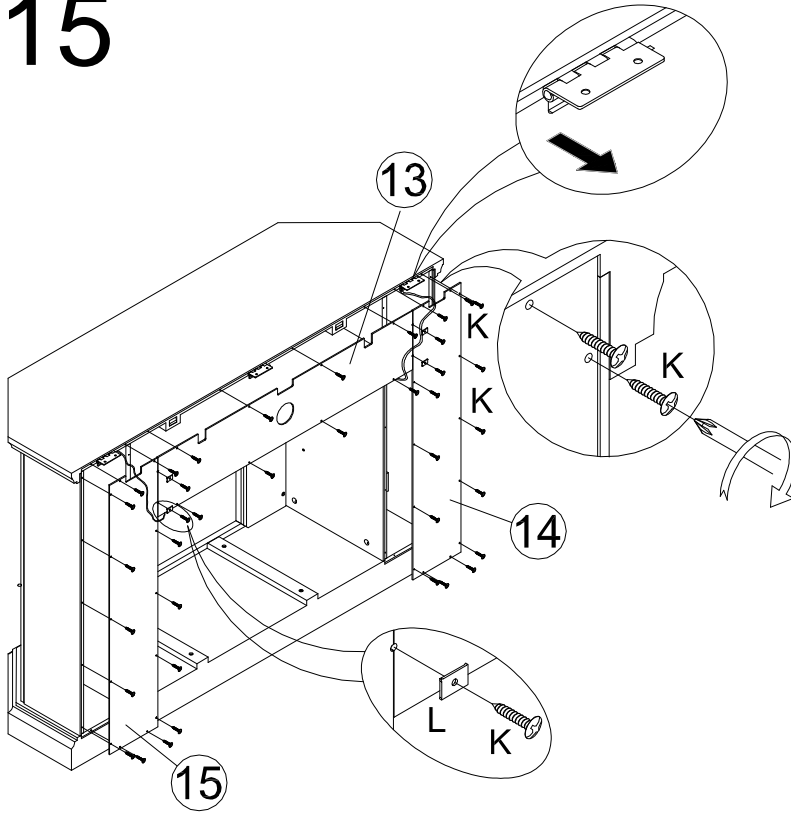

13

15



K		x 38
L		x 4

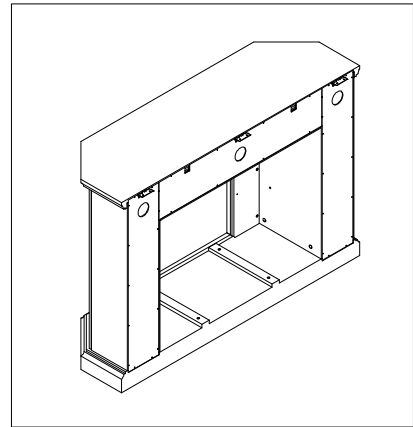

16

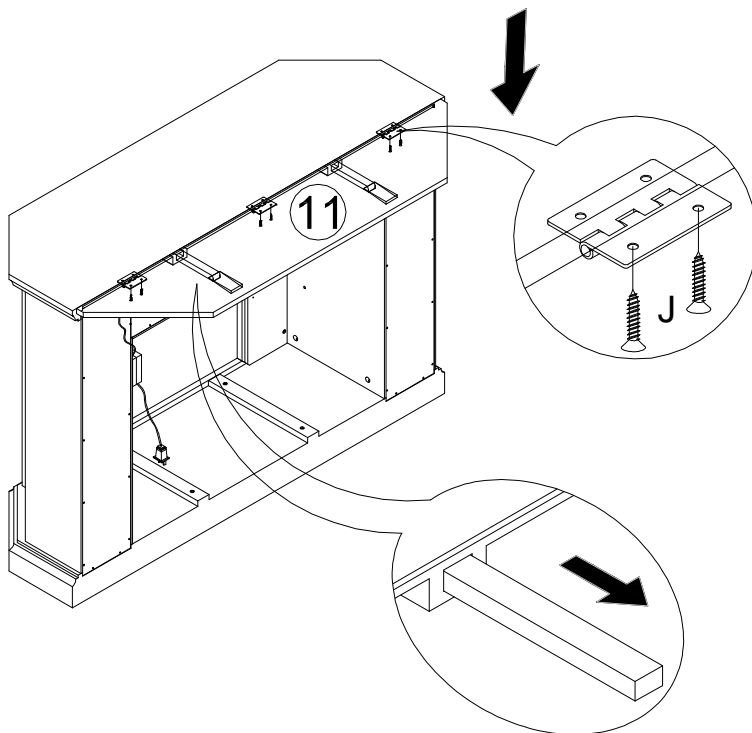



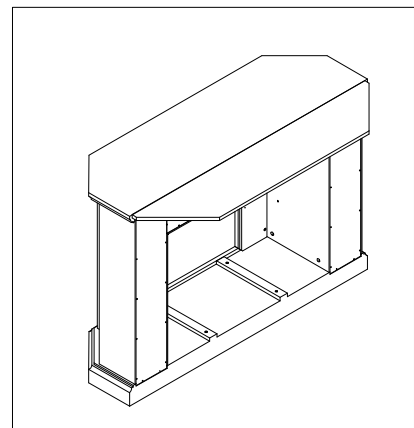

J		x 6
---	---	-----

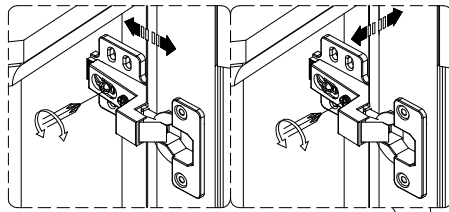

14

17



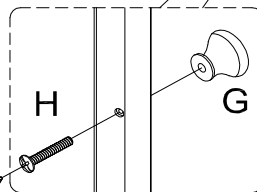
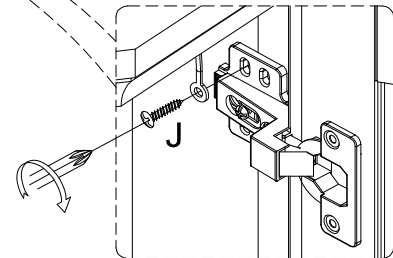
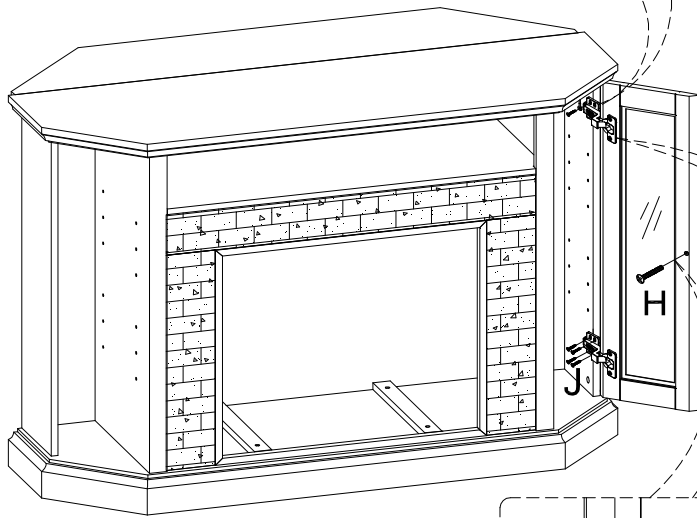

G		x 1
H		x 1
J		x 1

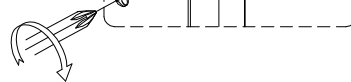

18-A



G		x 1
H		x 1

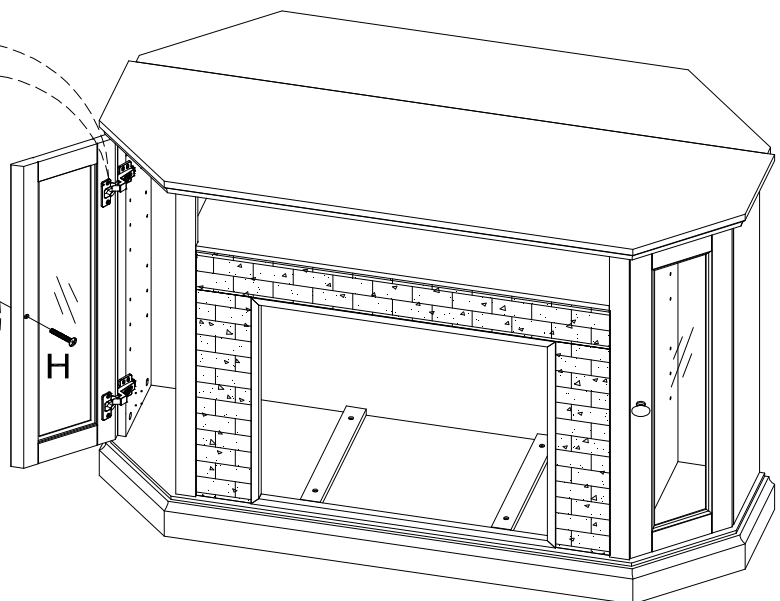
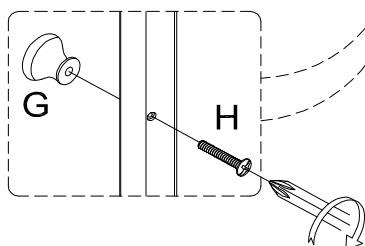
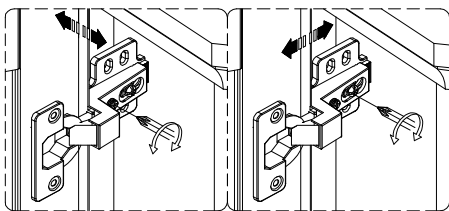

18-B

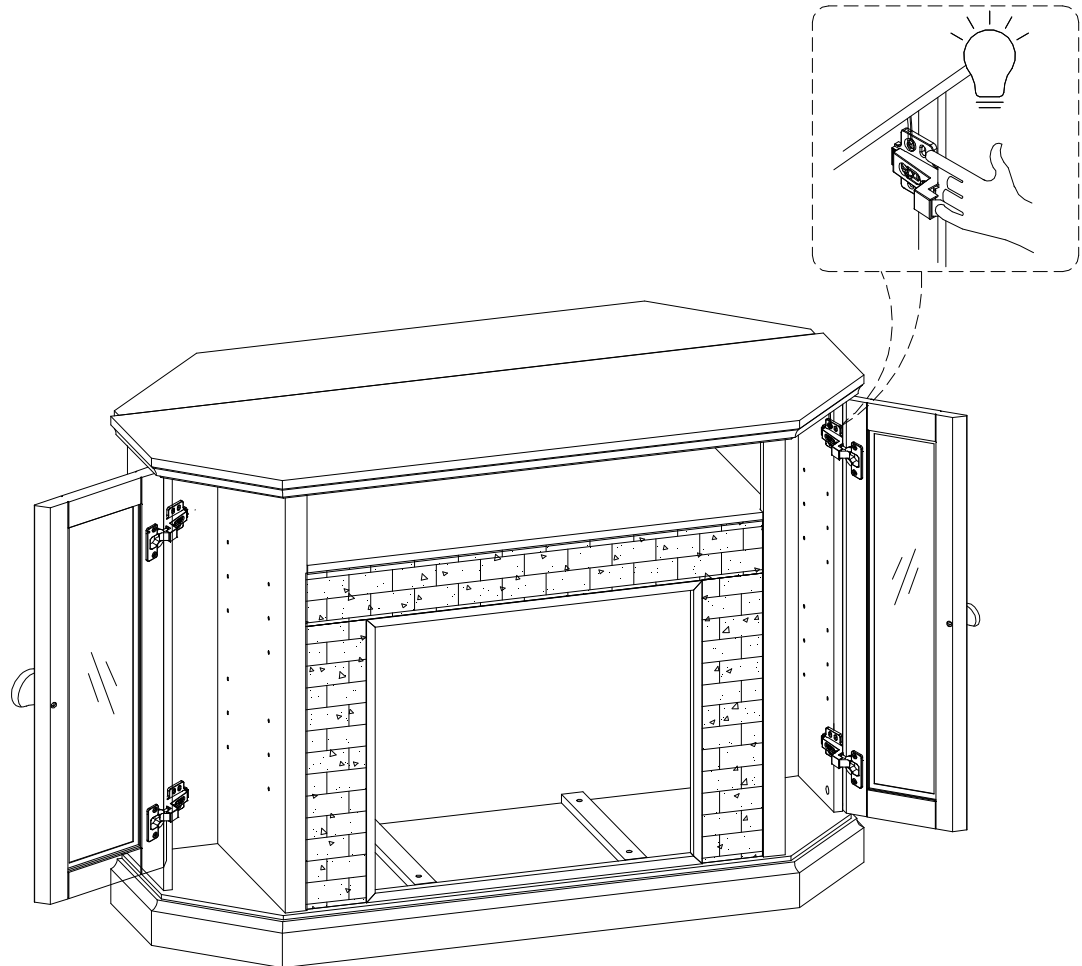

Touch Light | Toque de Luz | Lumi" re Tactile

To turn on touch light, touch top hinge on right door, when facing you.
Para encender la luz toque , toque la parte superior de la bisagra en la puerta de la derecha , que cuando se enfrentan a.

Pour allumer la lumi" re tactile, appuyez sur la charni" re sup" rieure de la porte " droite, face " vous.

16

19

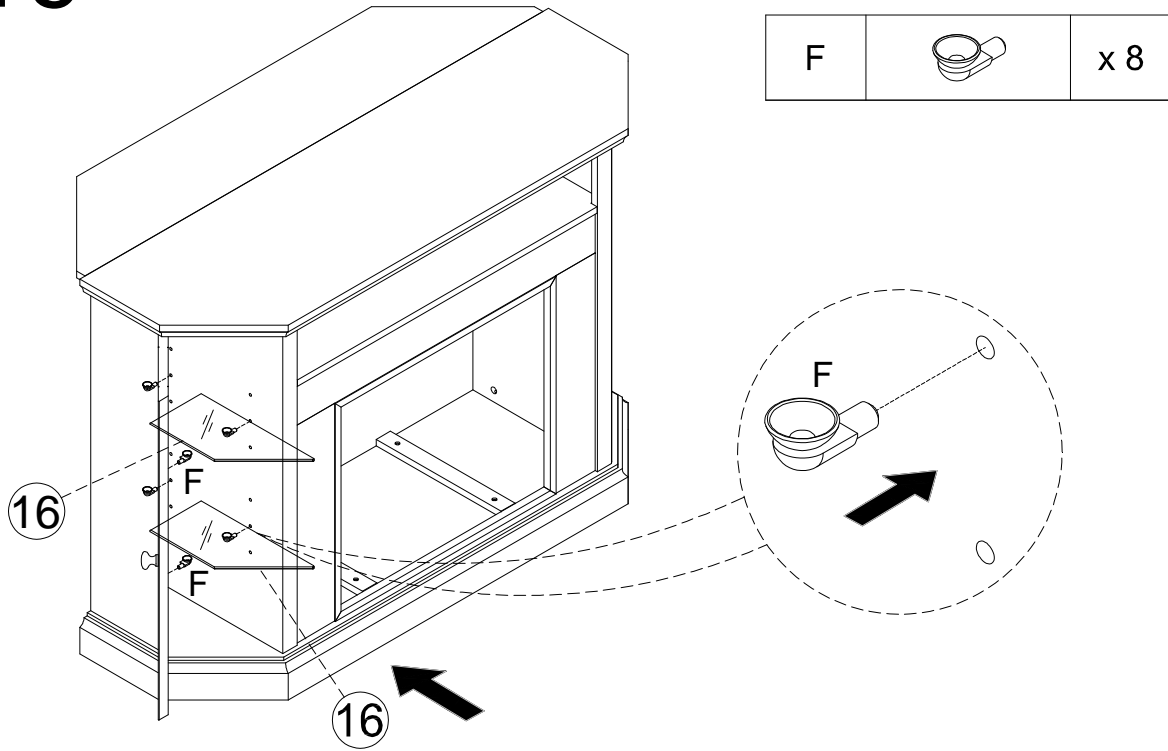

20

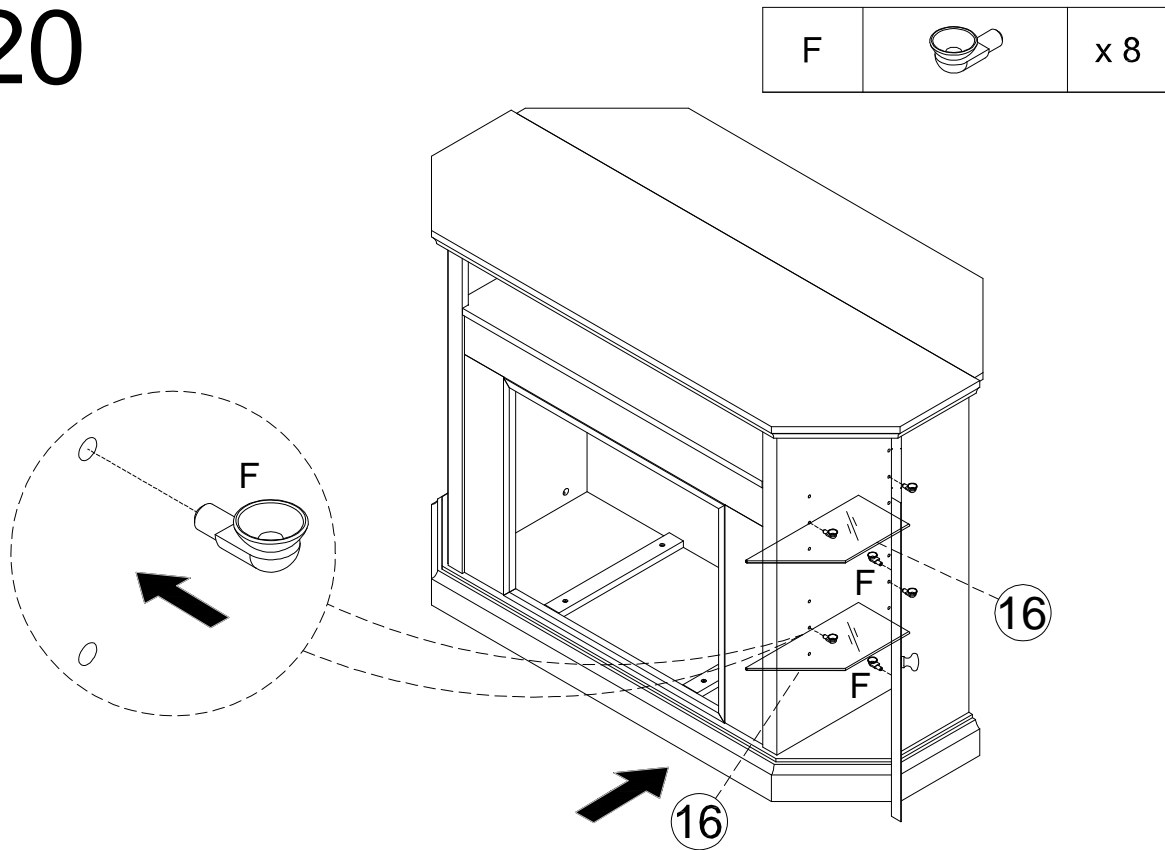

17

21

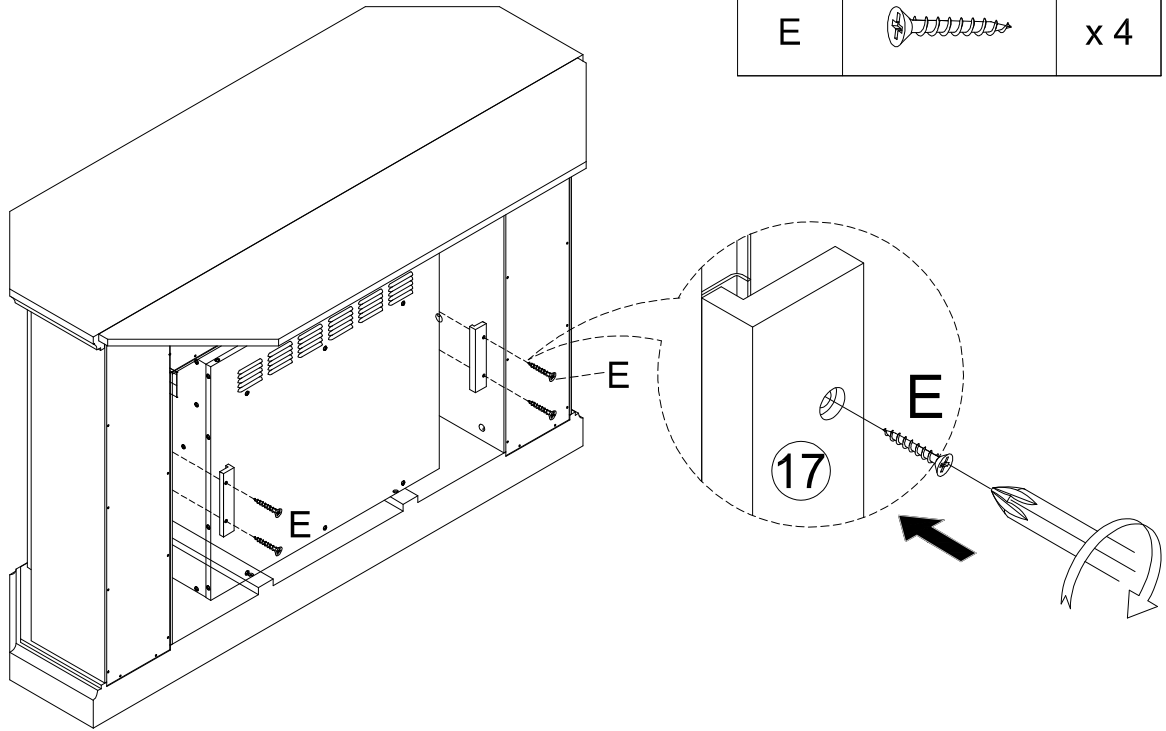

22

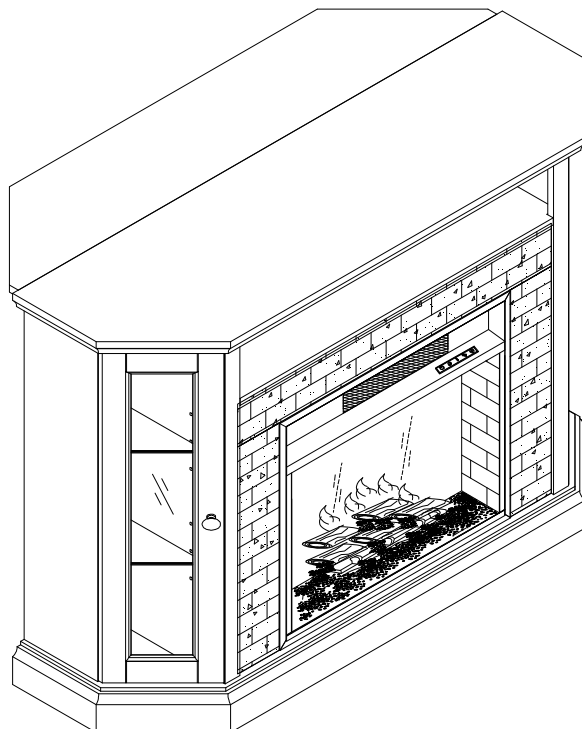

18

23

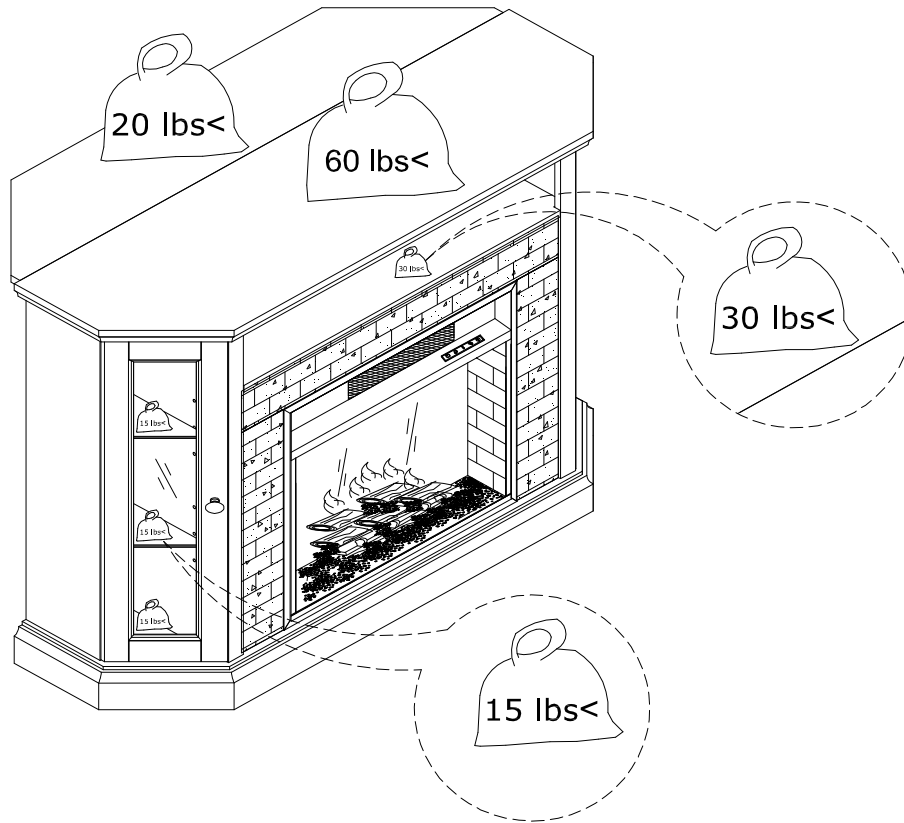

24

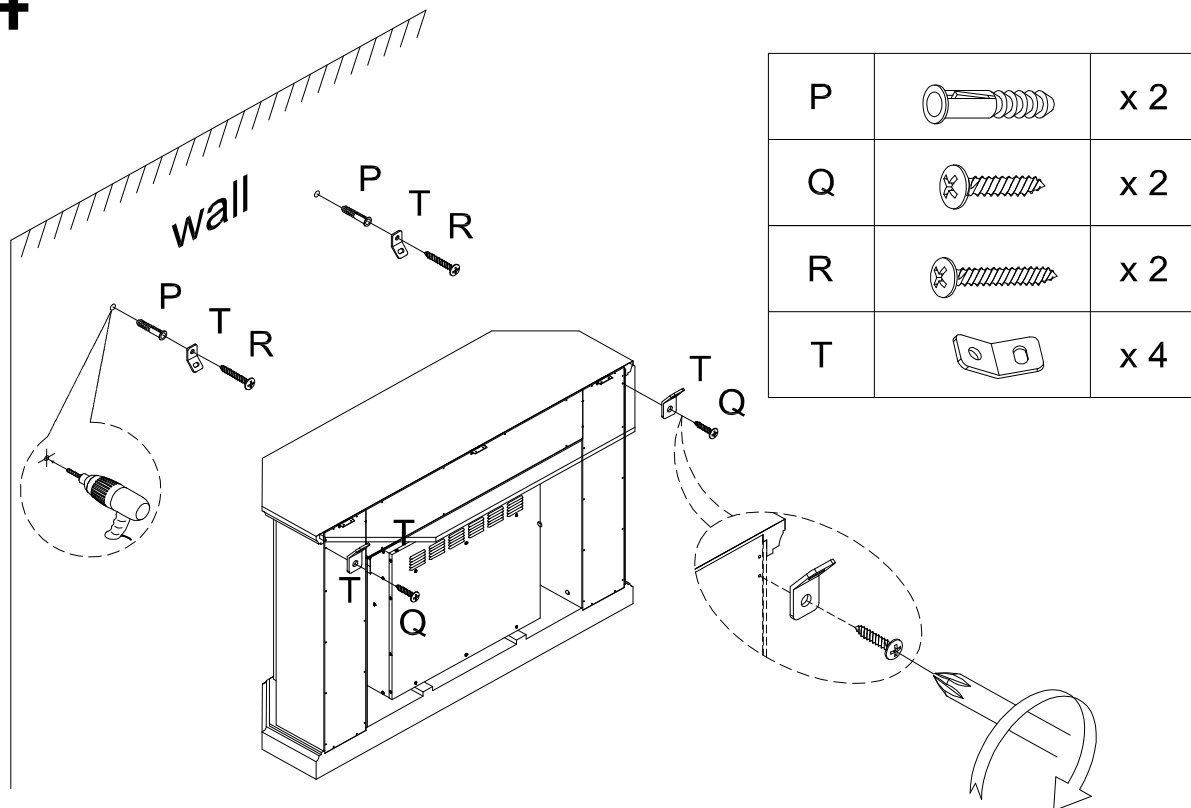

S		x 2
---	---	-----

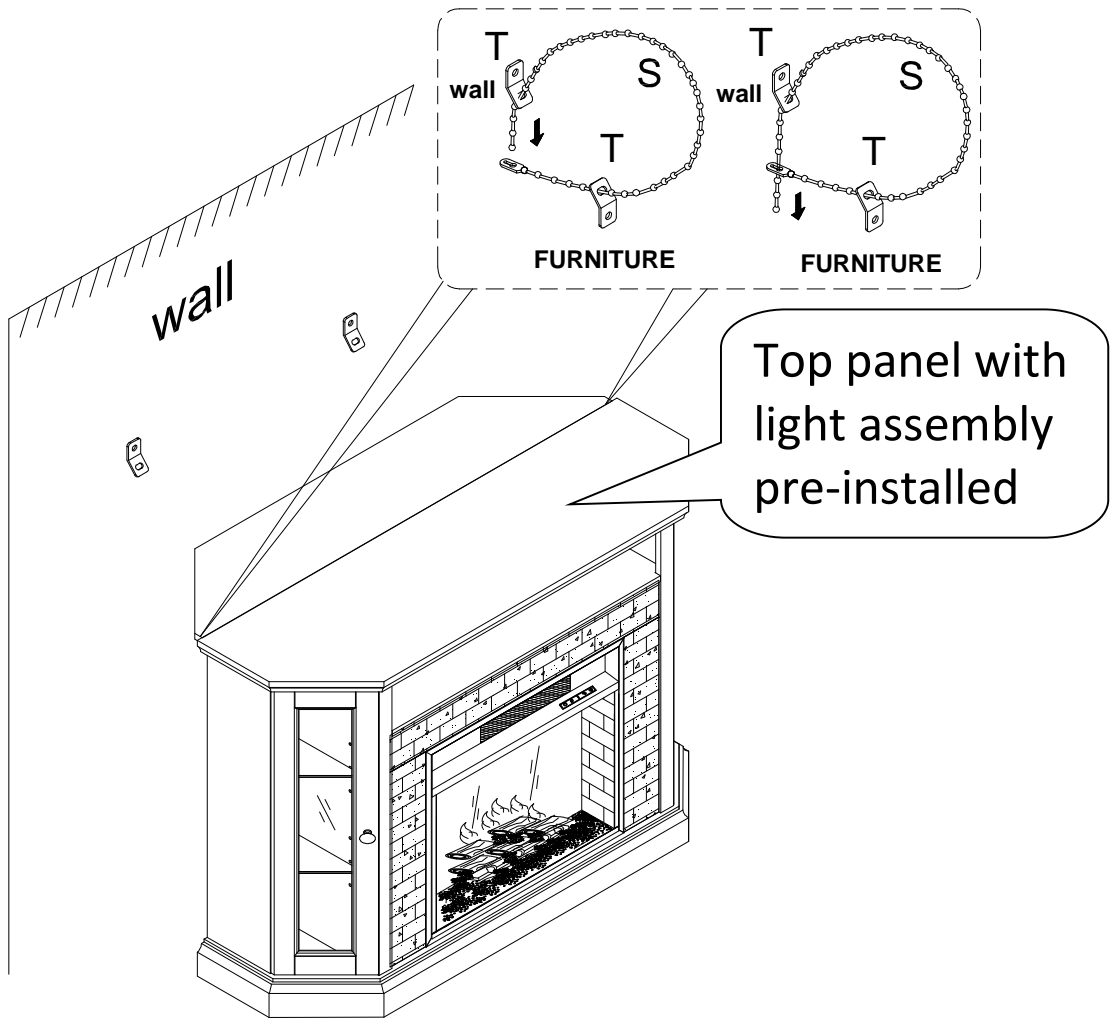

Assembly | Asamblea | Assemblage

Congratulations! | ¡Felicitaciones! | Félicitations!

Share Your Thoughts | Queremos conocer su opinión | Partagez vos impressions

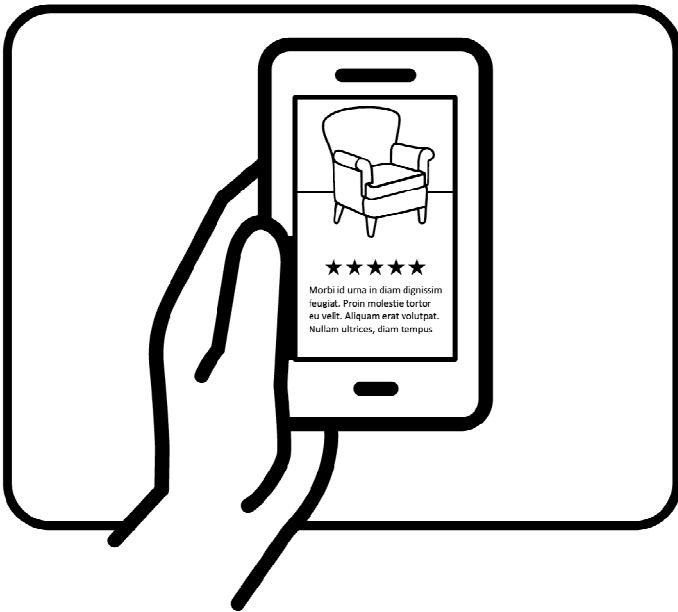
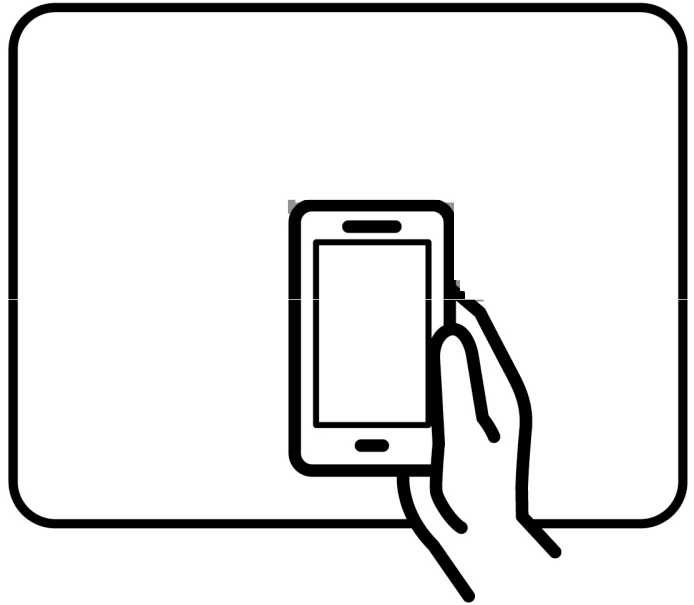
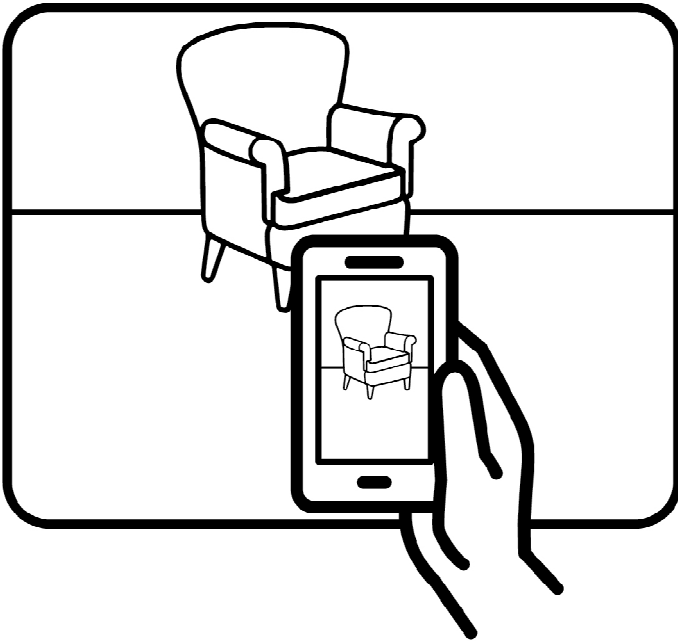

Assembly | Asamblea | Assemblage

May We Help You?

Have these ready when you call:

- Item Number
- PO #
- Purchaser Name
- Place of Purchase

Please immediately examine this product carefully. Any request for missing parts or damage replacement must be received within 90 days of your receipt of the product. Replacement, if available, will be honored within this time frame. Parts will not be available for items arriving fully assembled. We do not recommend modifying product(s) and we are not responsible for any damages due to product modification(s). If damages or missing parts are not reported within 90 days of your receipt, we are under no obligation to provide parts or replacement merchandise. For product issues, please contact or email us. Please ask for customer service representative for issues involving damages or replacement parts. Please ask for technical assistance representative for any issues with product and assembly/ construction. Please contact the retailer that you purchased from for returns.