

STEP 5

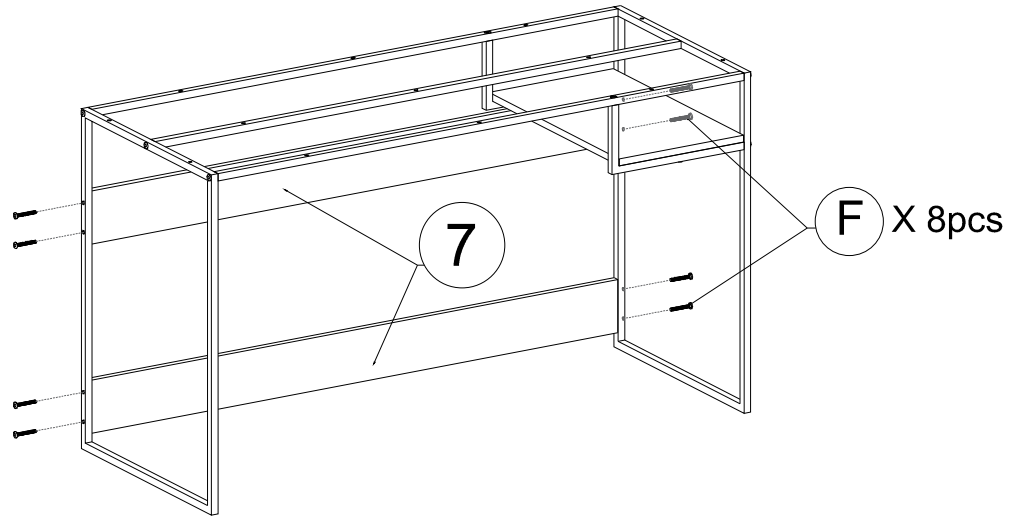

STEP 6

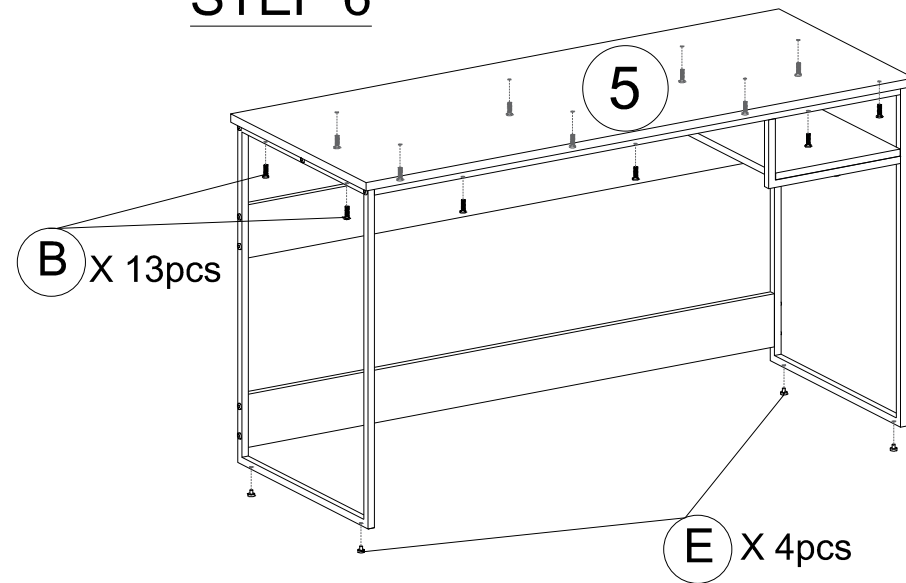

Recommended Maximum Weight

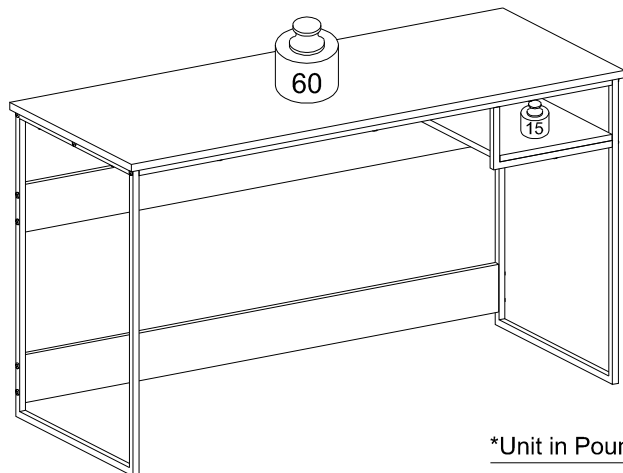

*Unit in Pound(lbs.)

WARNING:

>This unit has been designed to support the maximum loads shown. Exceeding these load limits could cause sagging, instability, product collapse, and/or serious injury.

>DO NOT allow children to climb on unit.

00:35

Approx. 35 minutes

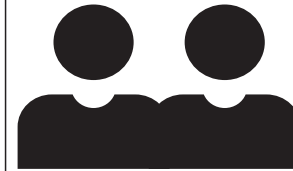

Recomm. 2 Persons

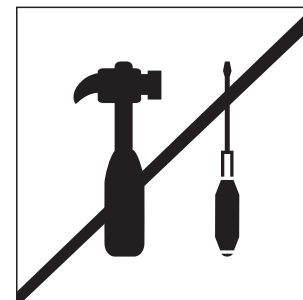





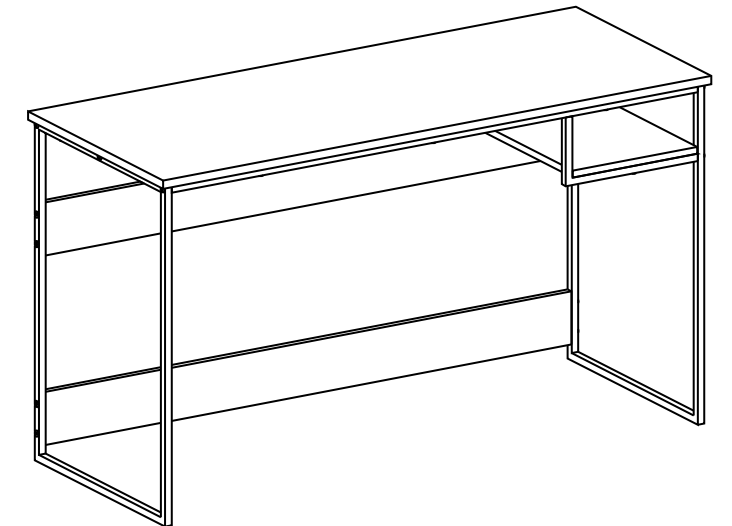

No Tools Required





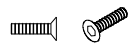

Assembly Instruction

Study Desk 52 Inch



HARDWARE & PARTS LIST

NO	HARDWARE LIST	QTY
A	LONG SCREW 	8pcs
B	SHORT SCREW 	15pcs
C	FLAT HEAD SCREW 	2pcs
D	ALLEN KEY 	1pc
E	RUBBER STUD 	4pcs
F	EXTRA LONG SCREW 	8pcs
G	BARREL NUT 	8pcs

NO	PARTS LIST	QTY
1	METAL FRAME A 	1pc
2	METAL FRAME B 	1pc
3	UPPER RAIL 	3pcs
4	L SHAPE RAIL 	2pcs
5	TOP PANEL 	1pc
6	SHELF PANEL 	1pc
7	SUPPORT PANEL 	2pcs

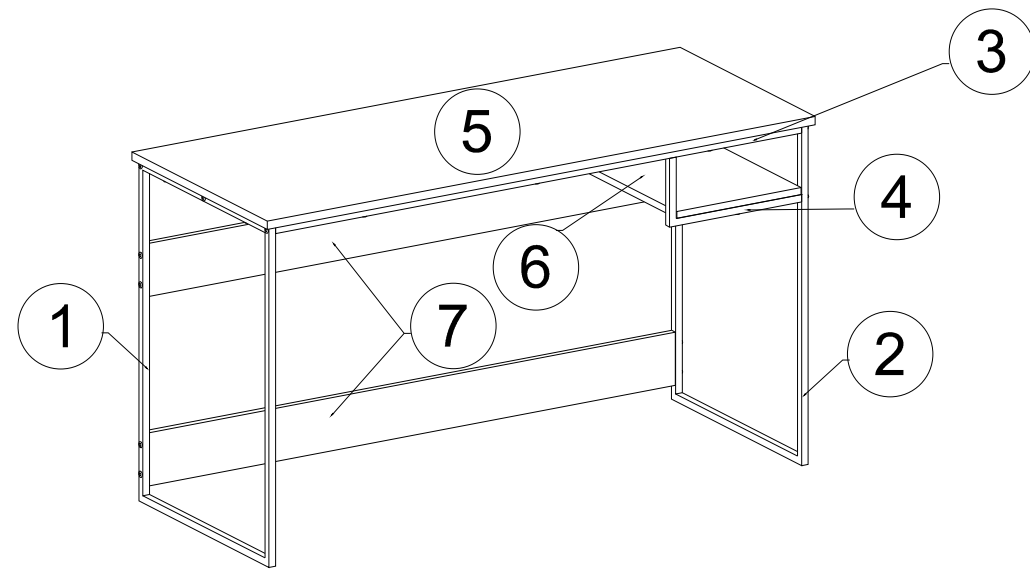

USEFUL HINTS BEFORE YOU START:

1. Read each step carefully before assembling.
2. It is important that each step is performed in correct order to avoid difficulties.
3. Identify, sort and count the parts before assembly.
4. Assemble your furniture on packaging cardboard to prevent scratch or damage.
5. Clean the product with mild cleanser using soft dampened cloth. Do not use harsh or abrasive cleanser.
6. Using incompatible hardware might cause damage to product.

ASSEMBLY INSTRUCTIONS

BEFORE YOU BEGIN, PLEASE READ ASSEMBLY INSTRUCTION CAREFULLY, FOLLOW THEM STEP BY STEP.

REMINDER: Please do not fully tighten any screw until all of them are in right positions.

STEP 1

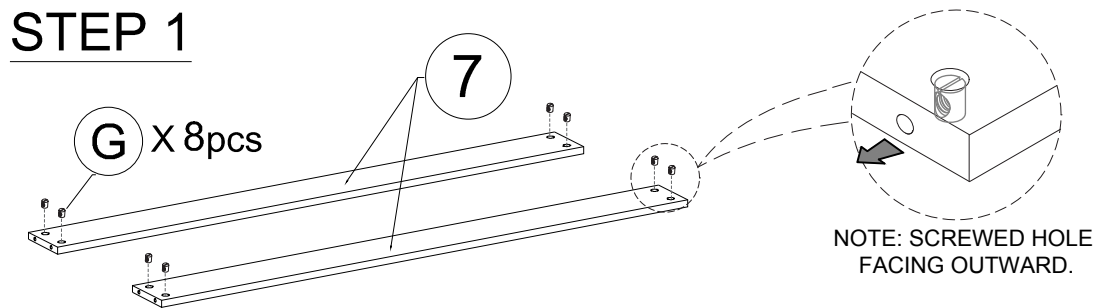

STEP 2

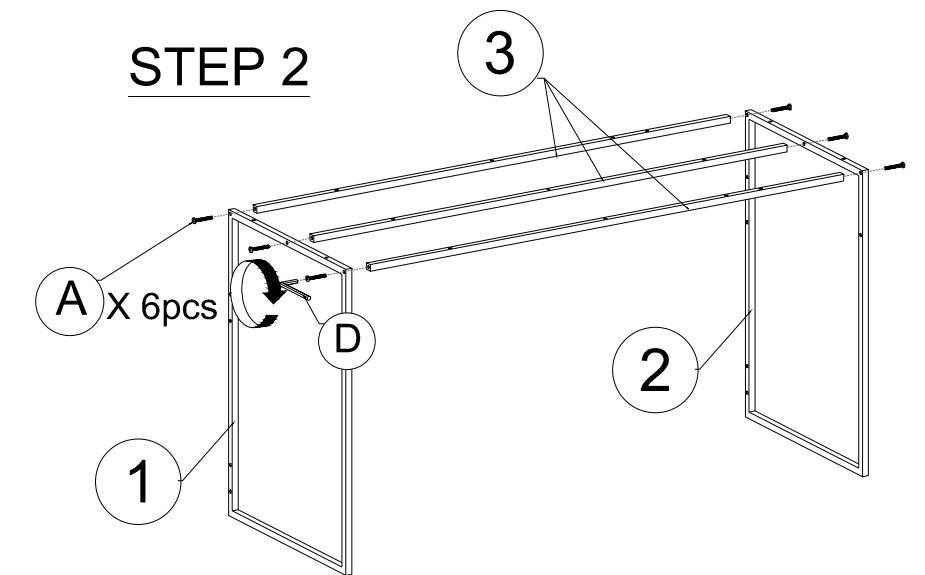

STEP 3

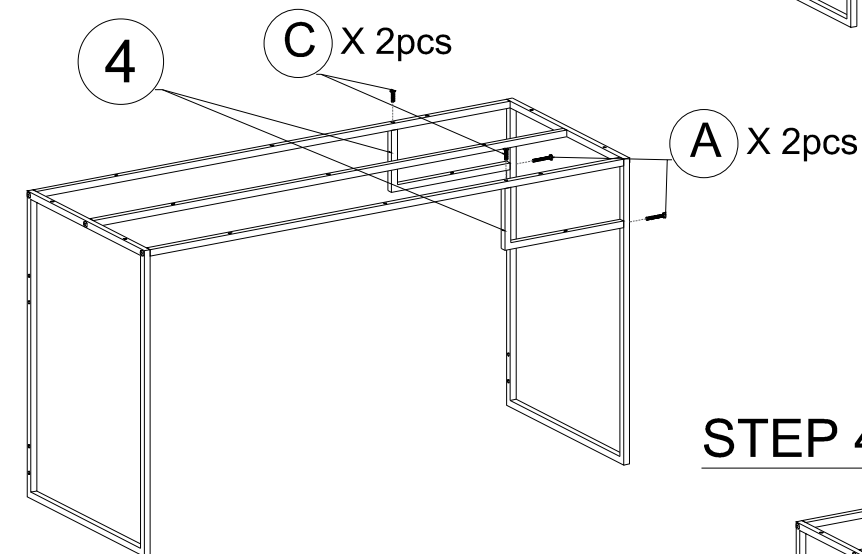

STEP 4

