

# Assembly Instruction Montageanleitung/

ITEM:N635P337195& N635P337198

## Kitchen Island Cabinet

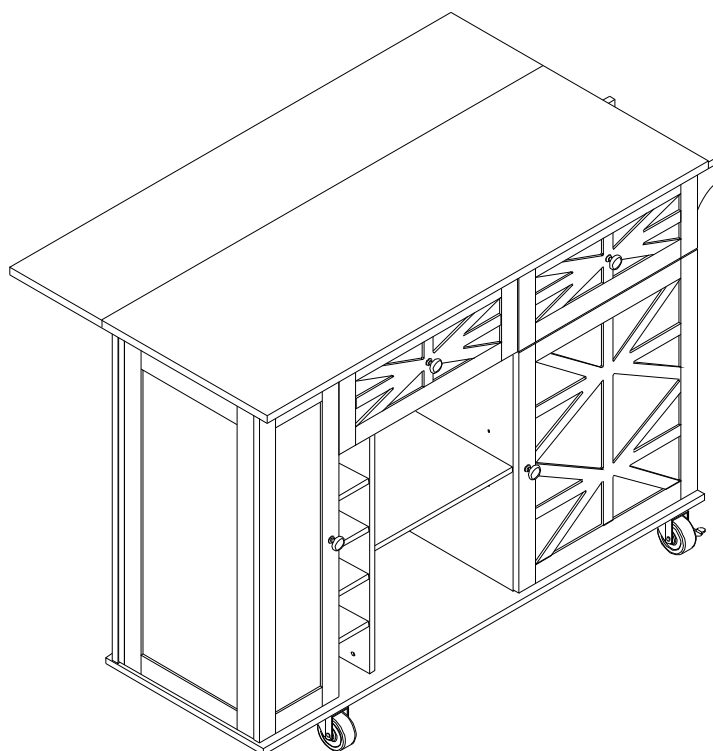

Importeur	Decobus Handel GmbH
Adresse	Innungsstraße 9, 21244 Buchholz, Deutschland
URL	<a href="https://www.decobusgroup.de">https://www.decobusgroup.de</a>
Hersteller	FUJIAN FENLIN HOUSEWARE CO.,LTD.
Adresse	NO.65 QIAOTOUYANG,XIAZHUANG VILLAGE,TAZHUANG TOWN, MINQING COUNTY,FUZHOU CITY,FUJIAN PROVINCE
Email	<a href="mailto:hansen_zj@163.com">hansen_zj@163.com</a>
	Decobus Handel GmbH Innungsstraße 9, 21244 Buchholz, Deutschland <a href="https://www.decobusgroup.de">https://www.decobusgroup.de</a>
	Hergestellt in China

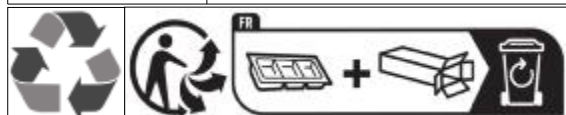

DE: Unser Produkt wird Ihnen in 2 Paketen geliefert. Die Lieferzeiten dieser 2 Pakete können abweichen, bitte haben Sie etwas Geduld und vielen Dank für Ihr Verständnis. Bitte lesen Sie diese Anweisungen vollständig durch, bevor Sie mit der Montage beginnen: Erforderliches Werkzeug: Kreuzschlitzschraubendreher (mittel und groß)

1. Überprüfen Sie, ob alle auf den folgenden Seiten aufgeführten Komponenten und Werkzeuge vorhanden sind.
  2. Entfernen Sie alle Zubehörteile aus den Plastiktüten und teilen Sie sie in ihre Gruppen auf.
  3. Halten Sie Kinder und Tiere vom Arbeitsbereich fern, es besteht Erstickungsgefahr durch Kleinteile wenn verschluckt.
  4. Stellen Sie sicher, dass Sie genügend Platz zum Anordnen der Teile haben, bevor Sie beginnen.
  5. Stellen Sie sich während der Montage nicht auf das Produkt und belasten Sie es nicht, da dies zu Schäden führen kann.
  6. Bauen Sie den Artikel so nah wie möglich an seiner endgültigen Position (im selben Raum) zusammen.
  7. Stellen Sie das Gerät auf eine weiche, ebene Oberfläche, um eine Beschädigung des Geräts oder Ihres Bodens zu vermeiden.
  8. Teile der Montage lassen sich einfacher mit 2 Personen durchführen.
  9. Um die Wahrscheinlichkeit einer Beschädigung Ihres Produkts zu verringern, stellen Sie bitte sicher, dass Ihre Bohrmaschine auf ein niedriges Drehmoment eingestellt ist.
  10. Setzen Sie alle Teile und Schrauben während der Montage locker zusammen. Erst wenn das Produkt fertig ist, sollten Sie die Schrauben vollständig festziehen.
  11. Überprüfen Sie regelmäßig und stellen Sie sicher, dass alle Schrauben und Anschlüsse ordnungsgemäß festgezogen sind.
  12. Bitte platzieren Sie keine Gegenstände, die die Tragfähigkeit überschreiten.
- Pflege und Wartung:  
Reinigen Sie es nur mit einem feuchten Tuch und einem milden Reinigungsmittel. Verwenden Sie keine Bleichmittel oder Scheuermittel.

UK:Our product will be delivered to you in 2 packages. The delivery times of these 2 packages may differ, please be patient and thank you for your understanding.Please read these instructions fully before starting assembly/

Tools required/ Phillips screwdriver(medium & large)

- 1.Check you have all the components and tools listed on the following pages.
- 2.Remove all fittings from the plastic bags and separate them into their groups.
- 3.Keep children and animals away from the work area, small parts could choke if swallowed.
- 4.Make sure you have enough space to layout the parts before starting.
- 5.During assembly do not stand or put weight on the product, this could cause damage.
- 6.Assemble the item as close to its final position (in the same room) as possible.
- 7.Assemble on a soft level surface to avoid damaging the unit or your floor.
- 8.Parts of the assembly will be easier with 2 people.
- 9.To reduce the likelihood of damaging your product please ensure that your power drill is set on a low torque setting.
- 10.Assemble all parts and bolts loosely during assembly, only once the product is complete should you fully tighten the bolts.
- 11.Regularly check and ensure That all bolts and fittings are tightend properly.
- 12.Please do not place items that exceed the load capacity.

Care and maintenance/

Only clean using a damp cloth and mild detergent, do no use bleach or abrasive cleaners.

FR:Notre produit vous sera livré en 2 paquets. Les délais de livraison de

Ces 2 forfaits peuvent différer, soyez patient et merci pour votre

Comprendre. Veuillez lire ces instructions complètement avant de commencer l'assemblage:

Outils requis: tournevis Phillips (moyen & grand)

1. Vérifiez que vous avez tous les composants et outils énumérés sur les pages suivantes.
2. Retirez tous les accessoires des sacs en plastique et séparez-les en groupes.
3. Gardez les enfants et les animaux loin de la zone de travail, les petites pièces pourraient s'étouffer

Si avalé.

4. Assurez-vous d'avoir suffisamment d'espace pour agencer les pièces avant de commencer.

5. Pendant l'assemblage ne tenez pas ou ne mettez pas de poids sur le produit, ceci pourrait causer

Dégâts.

6. Assemblez l'article le plus près possible de sa position finale (dans la même pièce).

7. Assemblez sur une surface plane douce pour éviter d'endommager l'unité ou votre plancher.

8. Les parties de l'assemblage seront plus faciles avec 2 personnes.

9. Pour réduire la probabilité d'endommager votre produit s'il vous plaît assurez-vous que votre

La perceuse électrique est réglée sur un réglage de couple faible.

10. Assemblez toutes les pièces et boulons librement pendant l'assemblage, seulement une fois le produit

Est complet si vous serrez complètement les boulons.

11. Vérifier régulièrement et s'assurer que tous les boulons et raccords sont bien serrés.

12. Veuillez ne pas placer les articles qui dépassent la capacité de charge.

Entretien et entretien:

Nettoyer uniquement à l'aide d'un chiffon humide et d'un détergent doux, ne pas utiliser d'eau de javel ou d'abrasif

Nettoyants.

IT:Il nostro prodotto sarà consegnato in 2 confezioni. I tempi di consegna di  
Questi 2 pacchetti possono essere diversi, per favore siate pazienti e vi ringrazio  
Comprensione. Leggere attentamente queste istruzioni prima di iniziare il montaggio:

Strumenti richiesti: cacciavite Phillips (medio e grande)

1. Controlla di avere tutti i componenti e gli strumenti elencati nelle pagine seguenti.
2. Togliere tutti gli accessori dai sacchetti di plastica e separarli in gruppi.
3. Tenere i bambini e gli animali lontani dal luogo di lavoro, piccole parti potrebbero soffocare  
Se ingerito.

4. Assicuratevi di avere abbastanza spazio per sistemare le parti prima di iniziare.
5. Durante il montaggio non appoggiare il prodotto né pesarlo, ciò potrebbe causare

Danno.

6. Assemblare l'oggetto il più vicino possibile alla sua posizione finale (nella stessa stanza).
7. Assemblare su una superficie piana morbida per evitare danni all'unità o al pavimento.
8. Le parti dell'assemblea saranno più facili con 2 persone.
9. Per ridurre la probabilità di danneggiare il prodotto, si assicuri che il

Il trapano di potenza è regolato su una regolazione di coppia bassa.

10. Montare tutte le parti e i bulloni liberamente durante l'assemblaggio, solo una volta il  
prodotto

È completa se si chiude completamente i bulloni.

11. Controllare regolarmente e assicurarsi che tutti i bulloni e gli accessori siano ben stretti.
12. Non collocare oggetti che superino la capacità di carico.

Cura e manutenzione:

Pulire solo con un panno umido e un detergente leggero, non usare candeggina o abrasivo

Detergenti.

ES:Nuestro producto le será entregado en 2 paquetes. Los plazos de entrega de Estos 2 paquetes pueden diferir, por favor tenga paciencia y gracias por su Entendimiento. Por favor, lea estas instrucciones antes de comenzar el montaje:

Herramientas necesarias: destornautomático Phillips (mediano y grande)

1. Compruebe que tiene todos los componentes y herramientas listados en las siguientes páginas.
2. Retire todos los accesorios de las bolsas de plástico y separarlos en sus grupos.
3. Mantenga a los niños y los animales lejos de la zona de trabajo, las partes pequeñas se pueden asfixi.

En caso de ingestión.

4. Asegúrese de tener suficiente espacio para diseñar las piezas antes de empezar.
5. Durante el montaje no se ponga de pie o poner peso sobre el producto, esto podría causar

Daños.

6. Montar el objeto lo más cerca posible de su posición final (en la misma habitación).
7. Montar sobre una superficie suave para evitar dañar la unidad o el suelo.
8. Las partes de la Asamblea será más fácil con 2 personas.
9. Para reducir la probabilidad de dañar su producto por favor asegúrese de que su La perforadora de potencia se ajusta con un par de torsión bajo.
10. Montar todas las piezas y pernos sueldurante el montaje, sólo una vez que el producto Es completa en caso de que plenamente apretar los tornillos.
11. Comprobar periódicamente y asegurarse de que todos los pernos y accesorios se aprietan correctamente.
12. Por favor no coloque artículos que excedan la capacidad de carga.

Cuidado y mantenimiento:

Sólo limpie con un paño húmedo y detergente suave, no utilice blanqueador ni abrasivo Limpiadores.

# Assembly Instruction / Montageanleitung

ITEM:N635P337195& N635P337198

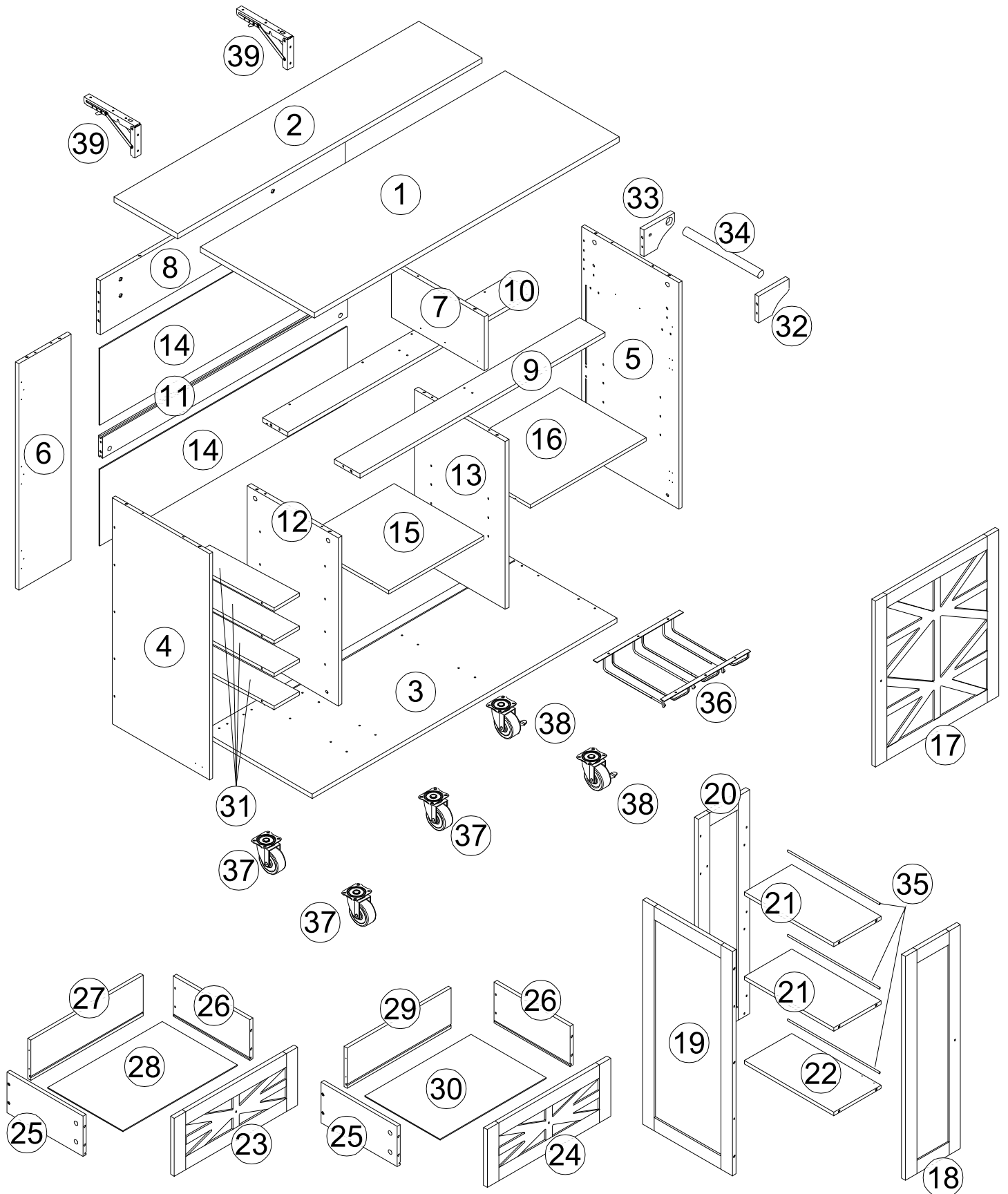

# Teileliste / Part List / Liste des pièces / Elenco delle parti / Lista de piezas

Please check you have all the panels listed below

/Bitte überprüfen Sie, ob alle unten aufgeführten Panels vorhanden sind

Note: The quantities below are the correct amount to complete the assembly. In some cases more fittings may be supplied than are required. / Hinweis: Die unten angegebenen Mengen sind die richtigen Mengen, um die Montage abzuschließen. In manchen Fällen können mehr Armaturen geliefert werden, als erforderlich sind.

N635P337198

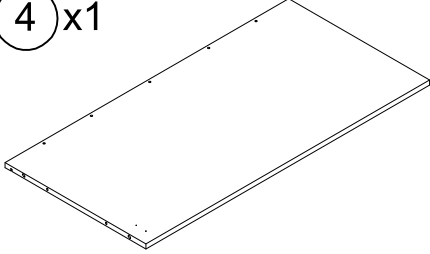
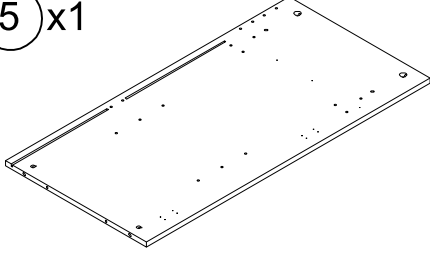
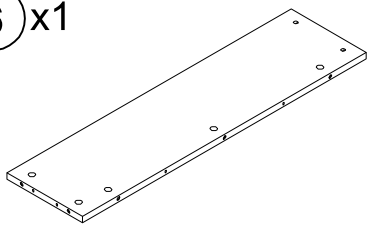
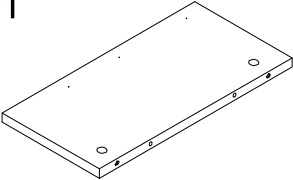
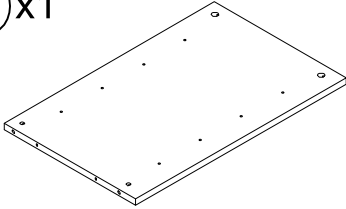
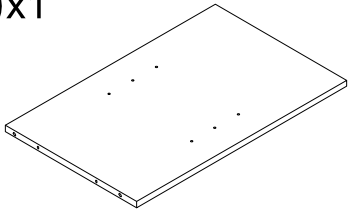
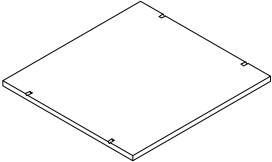
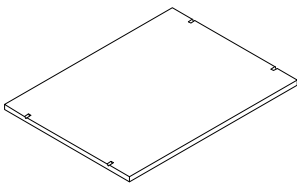
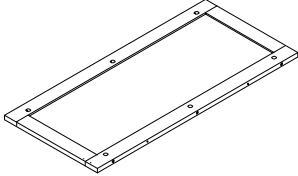
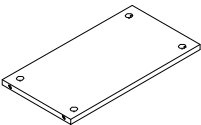
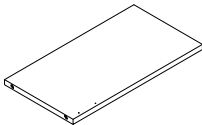
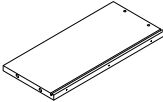
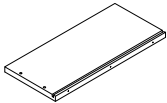
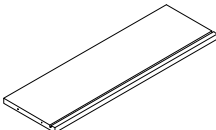
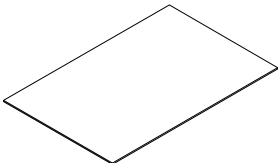
<p>④ x1</p>  <p>Left Panel</p>	<p>⑤ x1</p>  <p>Right Panel</p>	<p>⑥ x1</p>  <p>Rear Left Panel</p>
<p>⑦ x1</p>  <p>Upper Partiton</p>	<p>⑫ x1</p>  <p>Left Partition</p>	<p>⑬ x1</p>  <p>Right Partition</p>
<p>⑮ x1</p>  <p>Left Shelf</p>	<p>⑯ x1</p>  <p>Right Shelf</p>	<p>⑲ x1</p>  <p>Rack Side Frame</p>
<p>⑳ x2</p>  <p>Rack Shelf</p>	<p>㉒ x1</p>  <p>Rack Bottom</p>	<p>㉕ x2</p>  <p>Drawer Left Panel</p>
<p>㉖ x2</p>  <p>Drawer Left Panel</p>	<p>㉗ x1</p>  <p>Left Drawer Rear Panel</p>	<p>㉘ x1</p>  <p>Left Drawer Bottom</p>





# Teileliste / Part List / Liste des pièces / Elenco delle parti / Lista de piezas

Please check you have all the panels listed below

/Bitte überprüfen Sie, ob alle unten aufgeführten Panels vorhanden sind

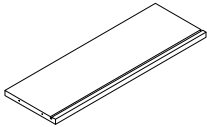
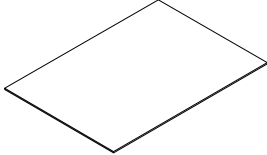
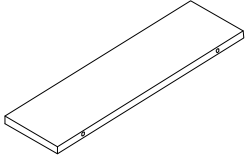
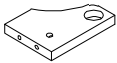
Note: The quantities below are the correct amount to complete the assembly. In some cases more fittings may be supplied than are required. / Hinweis: Die unten angegebenen Mengen sind die richtigen Mengen, um die Montage abzuschließen. In manchen Fällen können mehr Armaturen geliefert werden, als erforderlich sind.

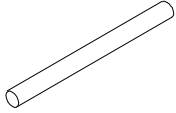
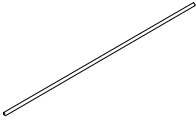
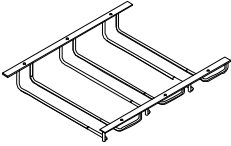
N635P337198

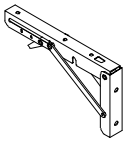
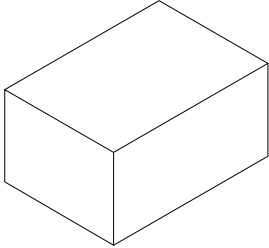
<p>②9)x1</p>  <p>Right Drawer Rear Panel</p>	<p>③0)x1</p>  <p>Right Drawer Bottom</p>	<p>③1)x4</p>  <p>Wine Rack Shelf panel</p>
<p>③2)x1</p>  <p>Towel Rack Left Panel</p>	<p>③3)x1</p>  <p>Towel Rack Right Panel</p>	<p>③4)x1</p>  <p>Rod</p>
<p>③5)x3</p>  <p>Spice Rack Rail</p>	<p>③6)x1</p>  <p>Glass Rack</p>	<p>③7)x3</p>  <p>Castor without Brake</p>
<p>③8)x2</p>  <p>Castor with Brake</p>	<p>③9)x2</p>  <p>Folding bracket</p>	
 <p>Hardware kit</p>		

Teileliste / Part List / Liste des pièces /  
Elenco delle parti / Lista de piezas

Please check you have all the panels listed below

/Bitte überprüfen Sie, ob alle unten aufgeführten Panels vorhanden sind

Note: The quantities below are the correct amount to complete the assembly. In some cases more fittings may be supplied than are required. / Hinweis: Die unten angegebenen Mengen sind die richtigen Mengen, um die Montage abzuschließen. In manchen Fällen können mehr Armaturen geliefert werden, als erforderlich sind.

N635P337195

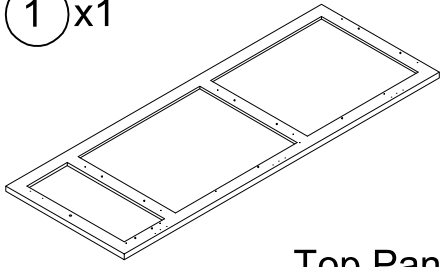
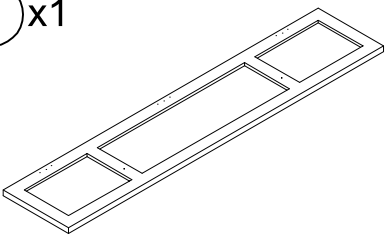
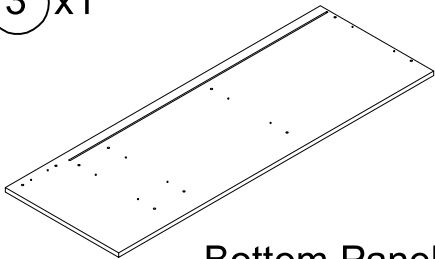
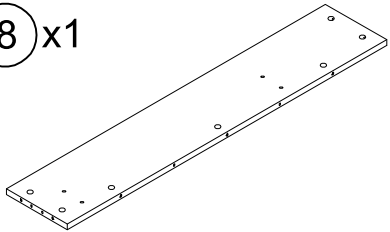
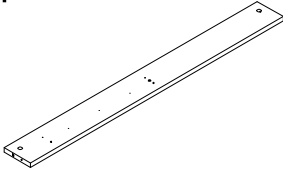
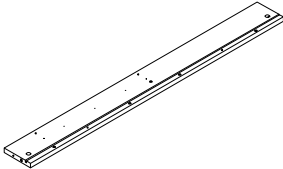
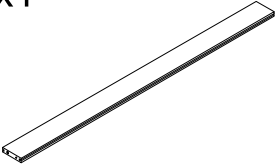
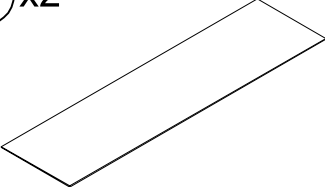
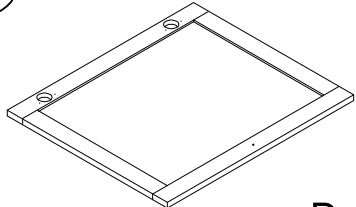
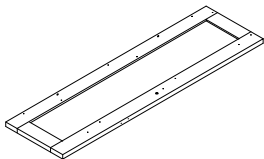
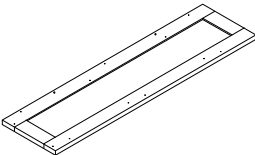
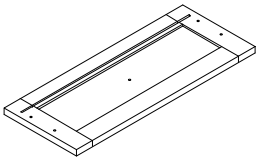
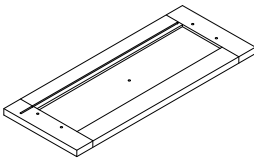









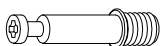

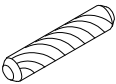
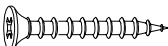







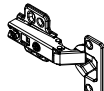

<p>① x1</p>  <p>Top Panel</p>	<p>② x1</p>  <p>Folding Top Panel</p>	<p>③ x1</p>  <p>Bottom Panel</p>
<p>⑧ x1</p>  <p>Rear Upper Crossbar</p>	<p>⑨ x1</p>  <p>Front Crossbar</p>	<p>⑩ x1</p>  <p>Rear Middle Crossbar</p>
<p>⑪ x1</p>  <p>Rear Lower Crossbar</p>	<p>⑭ x2</p>  <p>Back Panel</p>	<p>⑰ x1</p>  <p>Door</p>
<p>⑱ x1</p>  <p>Rack Door</p>	<p>⑳ x1</p>  <p>Rack Rear Panel</p>	<p>㉓ x1</p>  <p>Left Drawer Front panel</p>
<p>㉔ x1</p>  <p>Right Drawer Front panel</p>		

# Hardwareliste / Hardware List / Liste de matériel / Elenco hardware / Lista de hardware ITEM:N635P337195& N635P337198

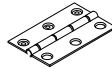
Please check you have all the panels listed below  
/Bitte überprüfen Sie, ob alle unten aufgeführten Panels vorhanden sind

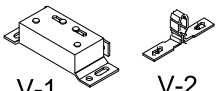
Note: The quantities below are the correct amount to complete the assembly. In some cases more fittings may be supplied than are required. / Hinweis: Die unten angegebenen Mengen sind die richtigen Mengen, um die Montage abzuschließen. In manchen Fällen können mehr Armaturen geliefert werden, als erforderlich sind.

## N635P337195& N635P337198

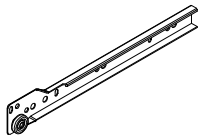
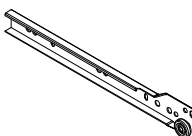
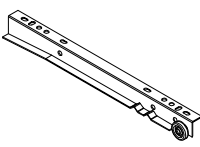
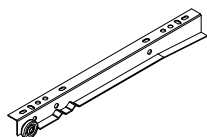
 A x 54PCS eccentric rod	 B x 54PCS eccentric rod gear	 C x 60PCS Dowel	 D x 14PCS Screw	 E x 18PCS Screw	 F x 36PCS Screw
 M6x45mm G x 12PCS Bolt	 M6x15mm H x 4PCS Bolt	 I x 4 PCS knob	 M4x14mm J x 4PCS Bolt	 K x 8PCS Shelf holder	 L x 12PCS T nut
 M x 2PCS Hinge	 M3x12mm N x 8PCS Screw	 M3x14mm O x 4PCS Screw	 P x 12PCS panel hook	 Q x 1PC stop bolt	 R x 1PC Tool
 S x 3PCS Hinge	 T x 3PCS Hinge	 U x 1PC Lock catch	 V-1 V-2 V x 2PCS Dog clamp	 M5x14mm W x 26PCS Screws	 M3.5x14mm X x 18PCS Screws
 Y x 2 Adjustable leg	 CL x2PCS Slide	 CR x2PCS Slide	 DL x2PCS Slide	 DR x2PCS Slide	

# Assembly Instruction Montageanleitung

ITEM:N635P337195& N635P337198

## Step 1

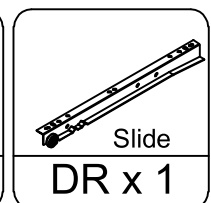
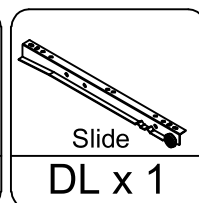
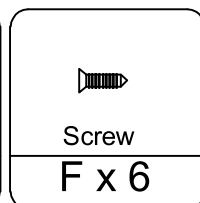
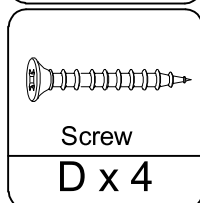
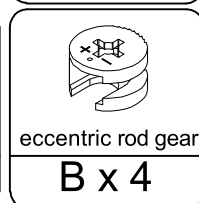
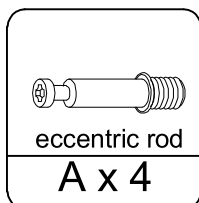
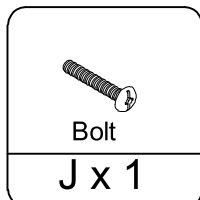
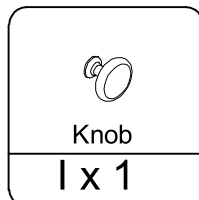
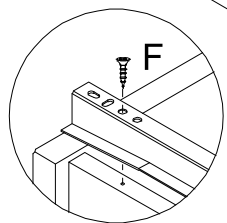
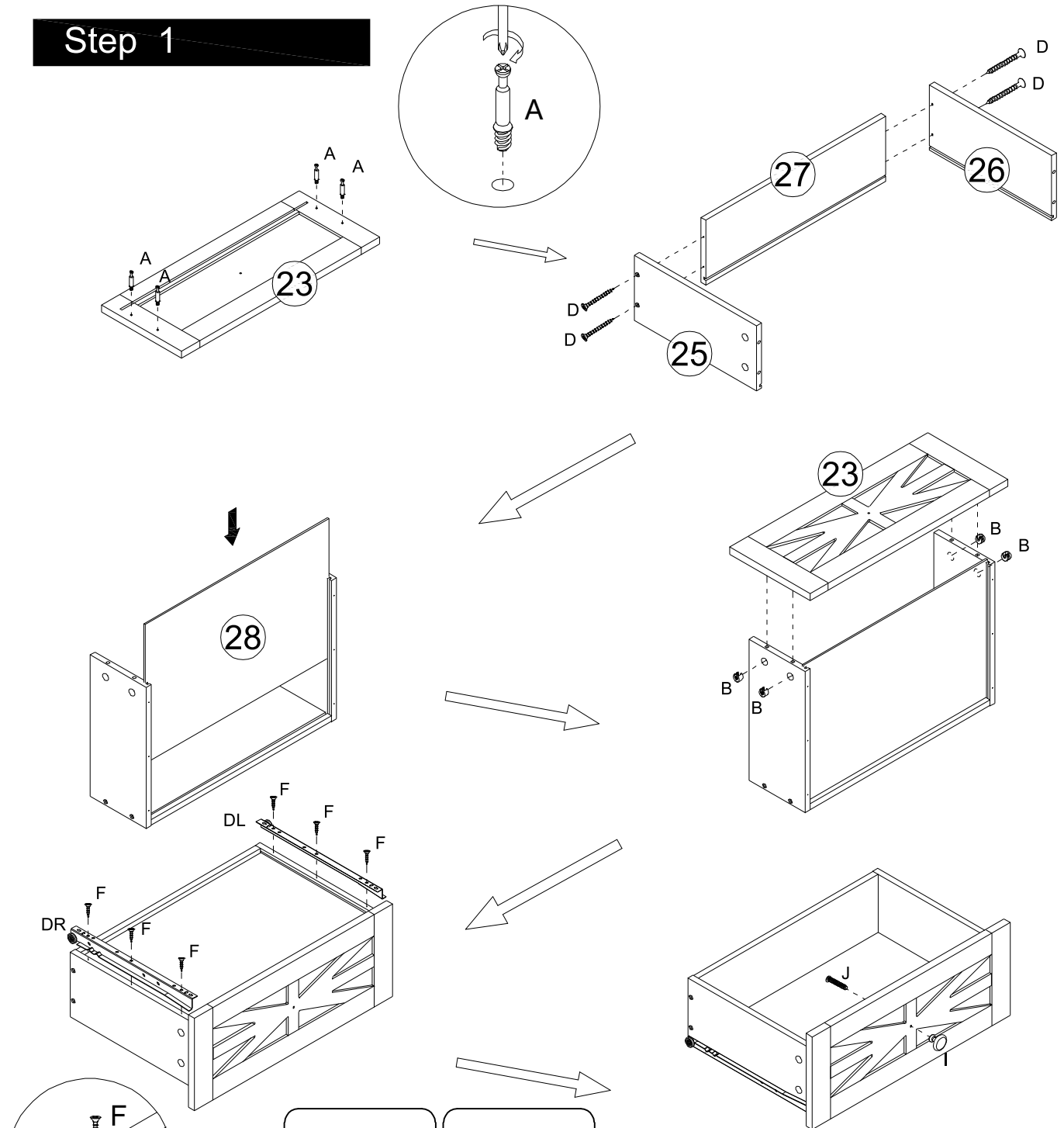







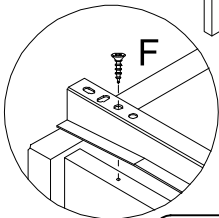
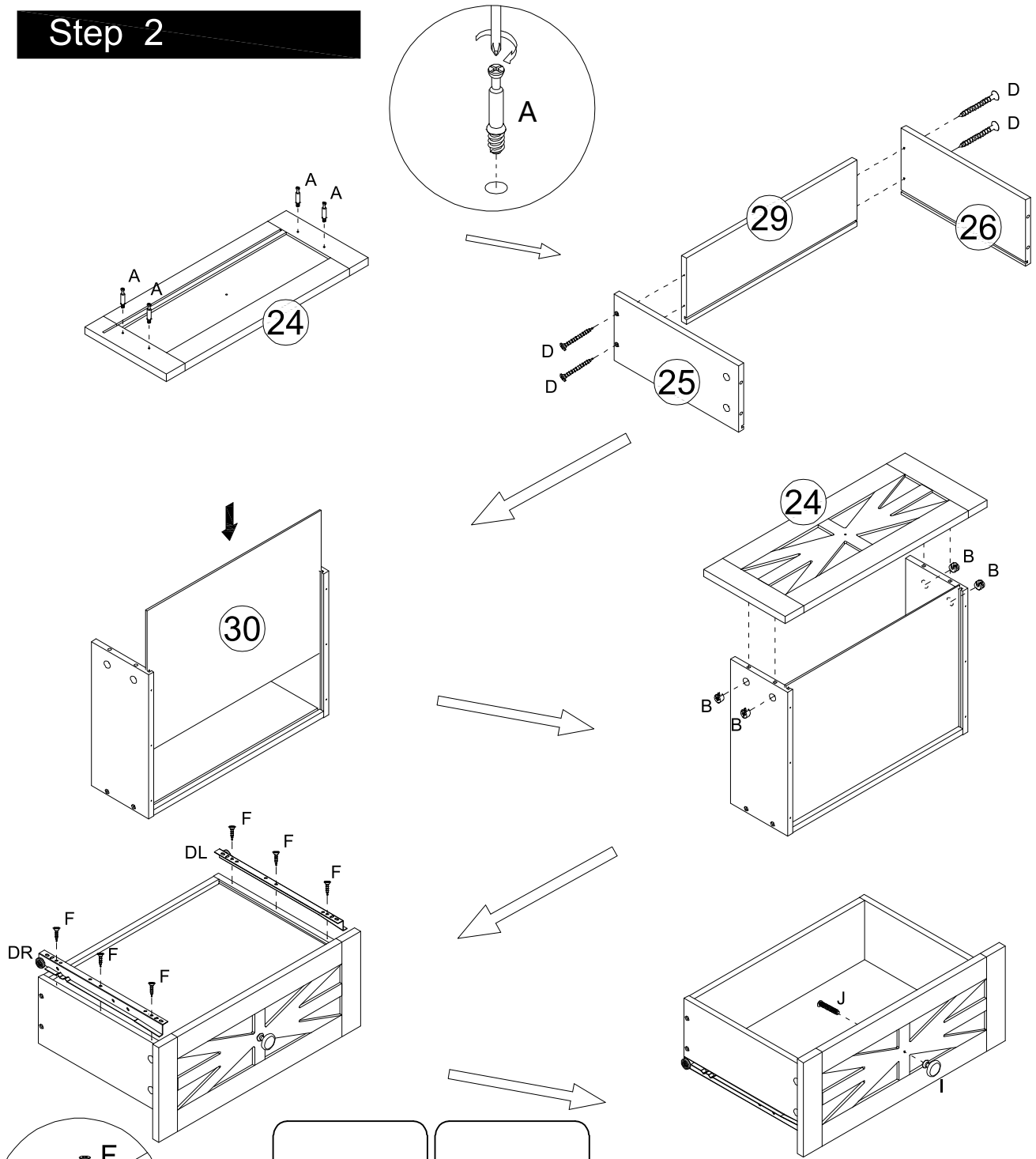

# Assembly Instruction Montageanleitung

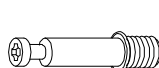
ITEM:N635P337195& N635P337198

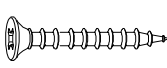
## Step 2



 Knob I x 1	 Bolt J x 1				
 eccentric rod A x 4	 eccentric rod gear B x 4	 Screw D x 4	 Screw F x 6	 Slide DL x 1	 Slide DR x 1

# Assembly Instruction Montageanleitung

## ITEM:N635P337195& N635P337198

### Step 3

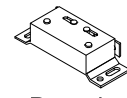
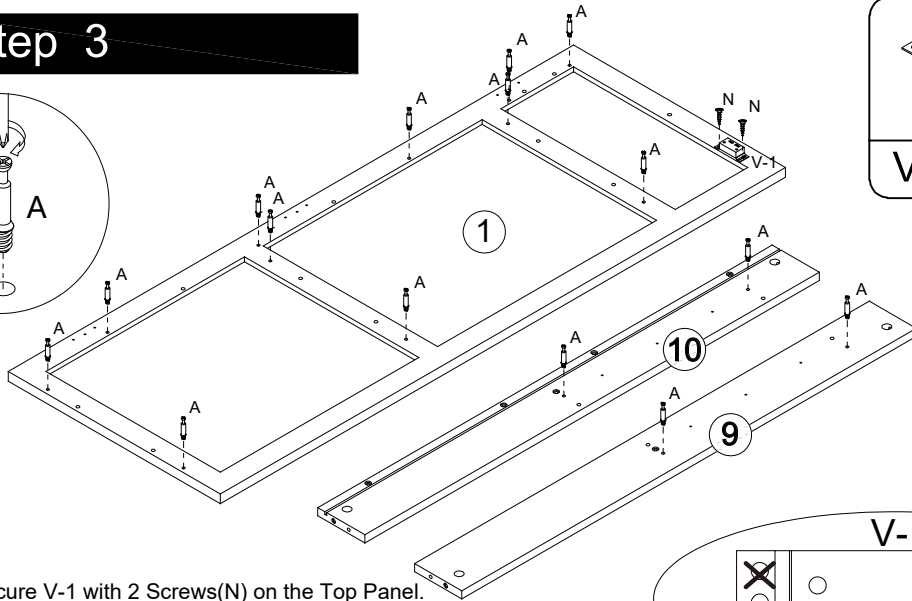
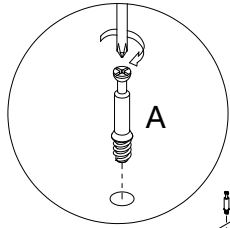

Dog clamp  
V-1 x 1

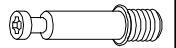

eccentric rod  
A x 15



Screw  
N x 2

Step 3.1 Secure V-1 with 2 Screws(N) on the Top Panel.  
Make sure that two mounting positions are both present in the elliptical holes, and make sure the mounting positions are aligned.  
Schritt 3.1 Befestigen Sie V-1 mit 2 Schrauben (N) an der oberen Abdeckung.  
Stellen Sie sicher, dass beide Befestigungspunkte in den elliptischen Löchern vorhanden sind und dass die Befestigungspunkte ausgerichtet sind.

Step 3.2 If no stuck are found, proceed to tighten both of the Screws.  
Ensure that the position of V-1 and V-2 are aligned and locked properly  
Ensure that V-1 and V-2 can be turned on and off smoothly.  
Schritt 3.2 Wenn keine Blockierungen festgestellt werden, ziehen Sie beide Schrauben fest.  
Stellen Sie sicher, dass die Positionen von V-1 und V-2 ausgerichtet und ordnungsgemäß arretiert sind.  
Stellen Sie sicher, dass V-1 und V-2 reibungslos ein- und ausgeschaltet werden können.

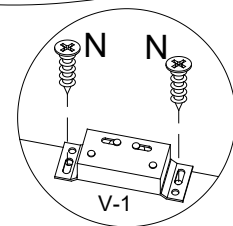
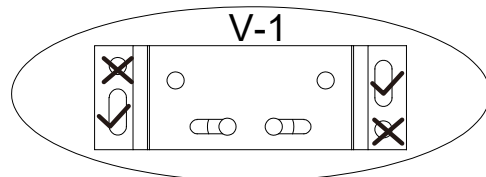

### Step 4

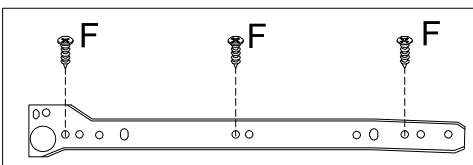
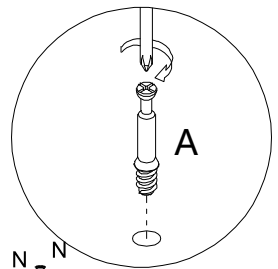
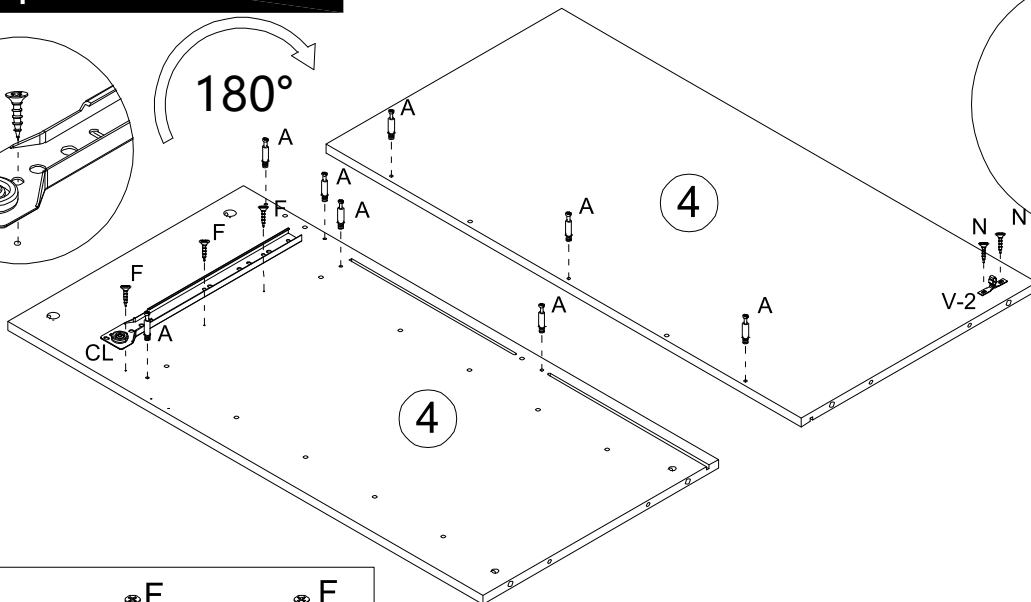
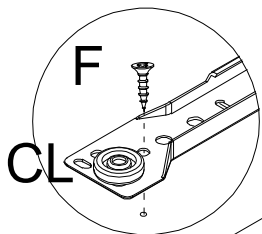

Dog clamp  
V-2 x 1

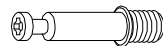

eccentric rod  
A x 8



Screw  
F x 3



Screw  
N x 2

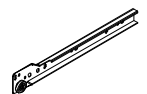



Slide  
CL x 1

# Assembly Instruction Montageanleitung

ITEM:N635P337195& N635P337198

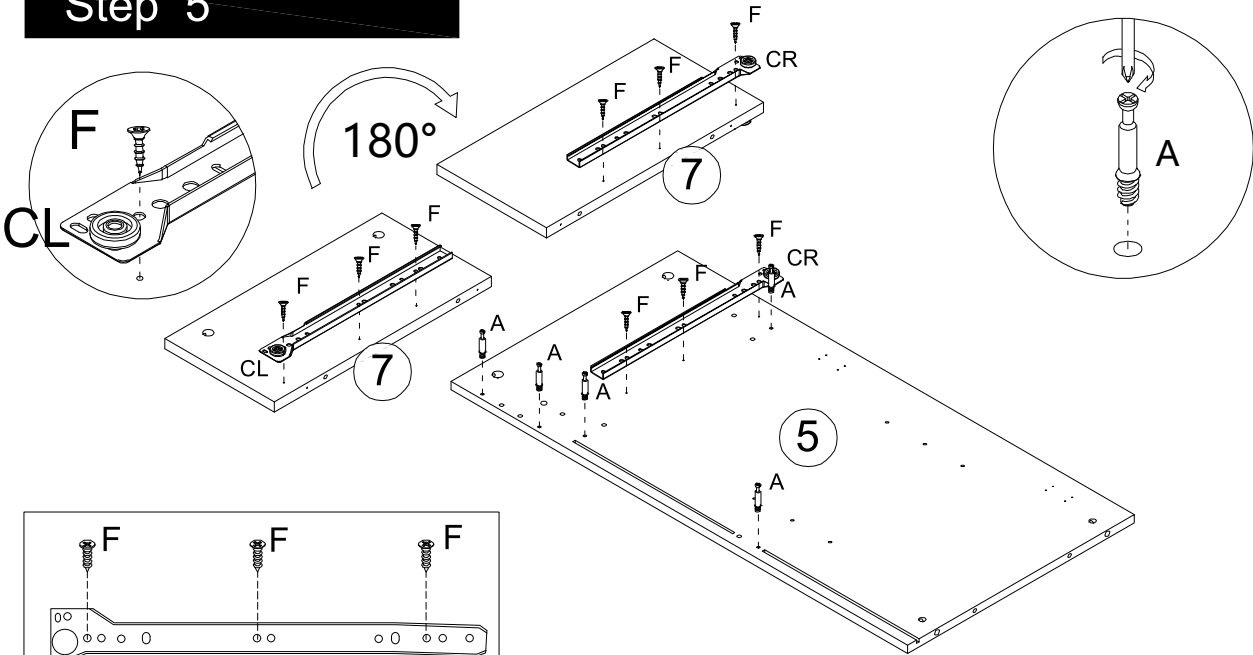
## Step 5

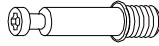

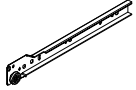
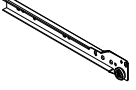
			
eccentric rod	Screw	Slide	Slide
A x 5	F x 9	CL x 1	CR x 2

## Step 6

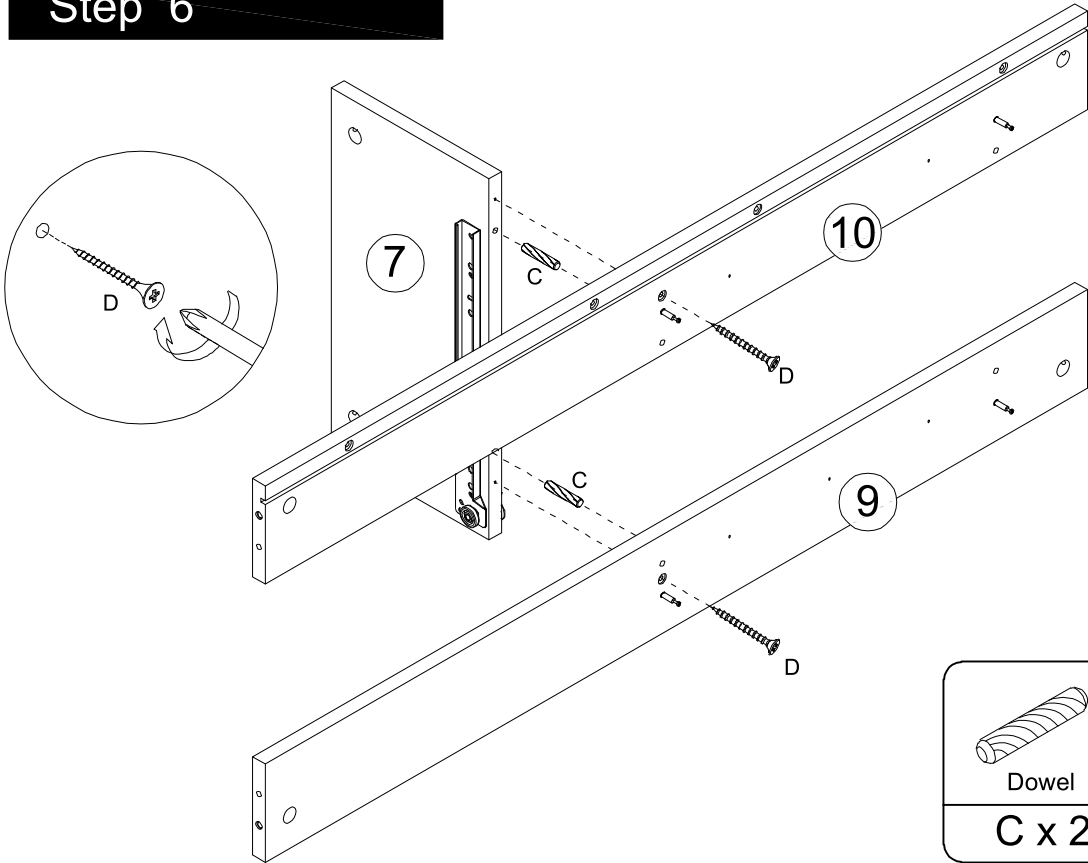

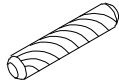
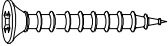
	
Dowel	Screw
C x 2	D x 2

# Assembly Instruction Montageanleitung

ITEM:N635P337195& N635P337198

## Step 7

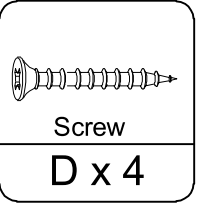
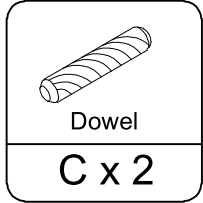
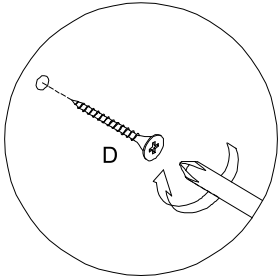
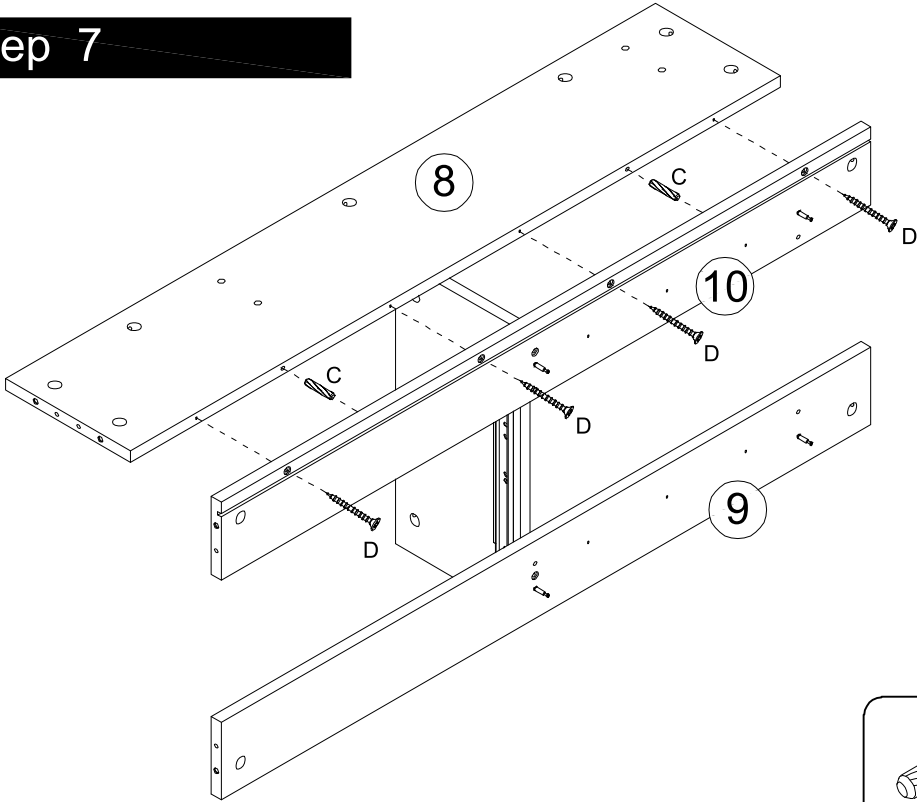

## Step 8

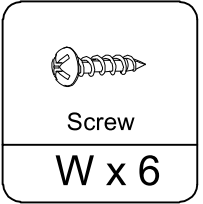
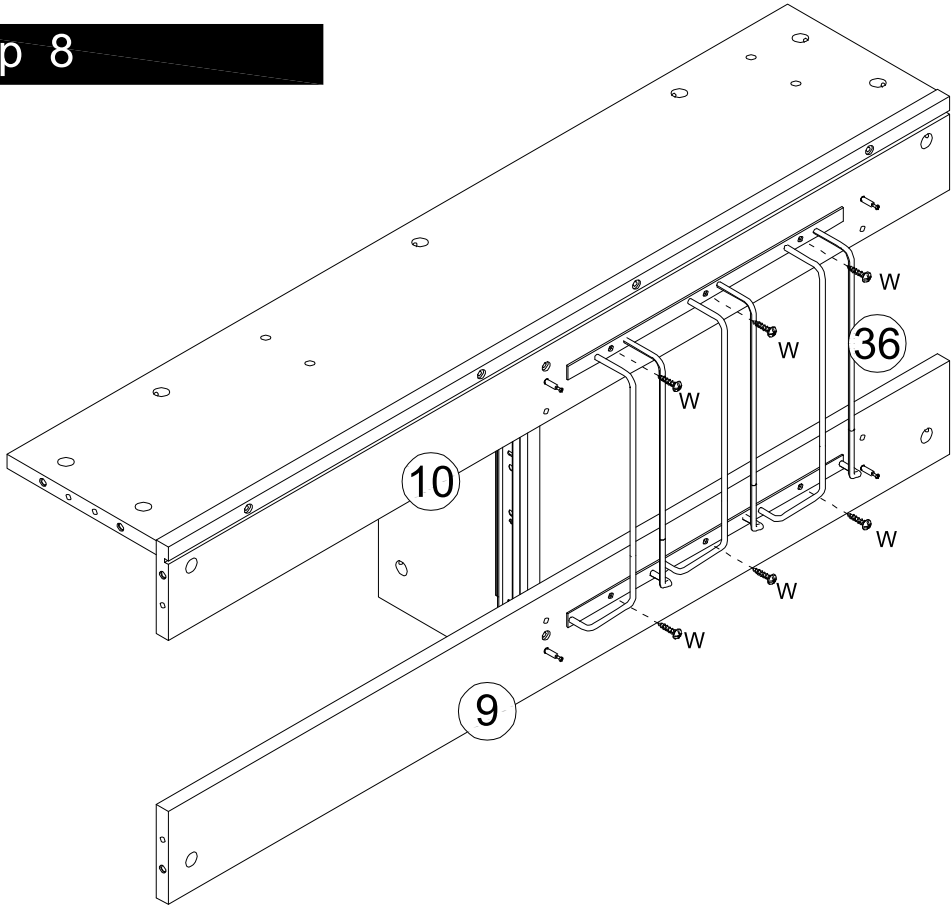

# Assembly Instruction Montageanleitung

ITEM:N635P337195& N635P337198

## Step 9

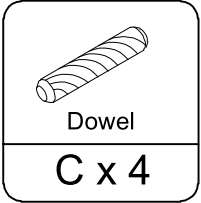
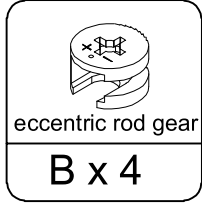
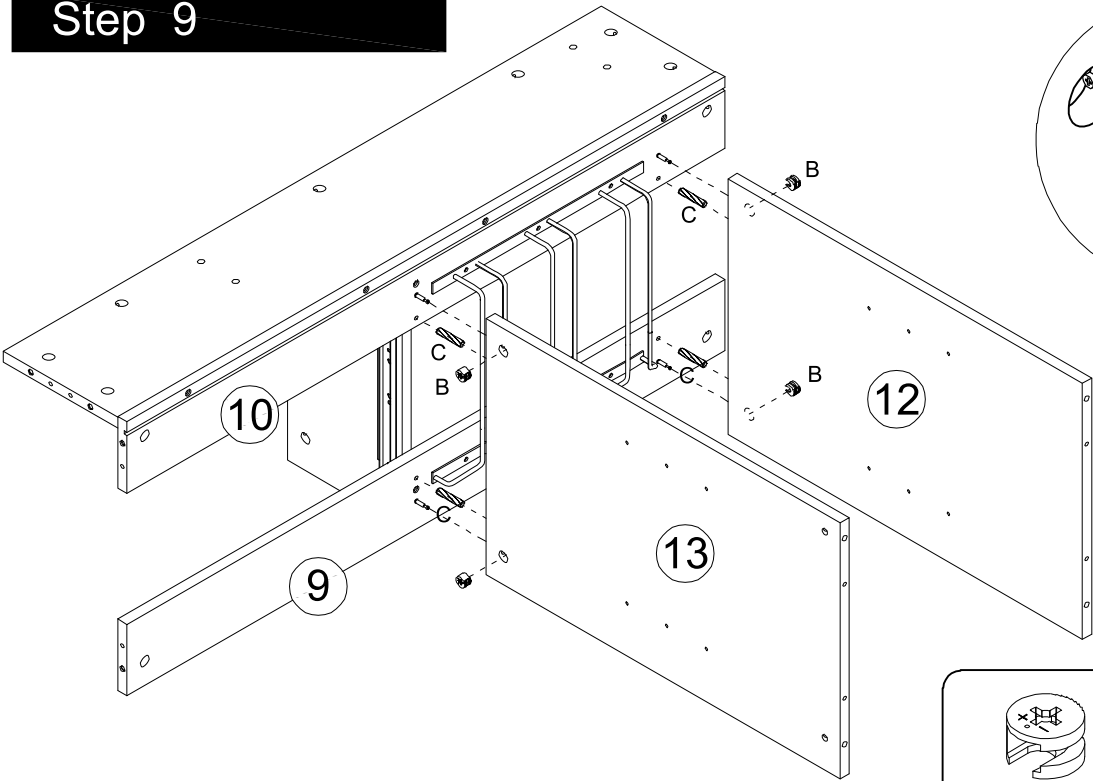

## Step 10

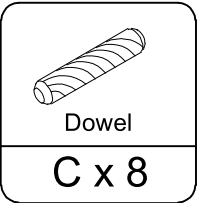
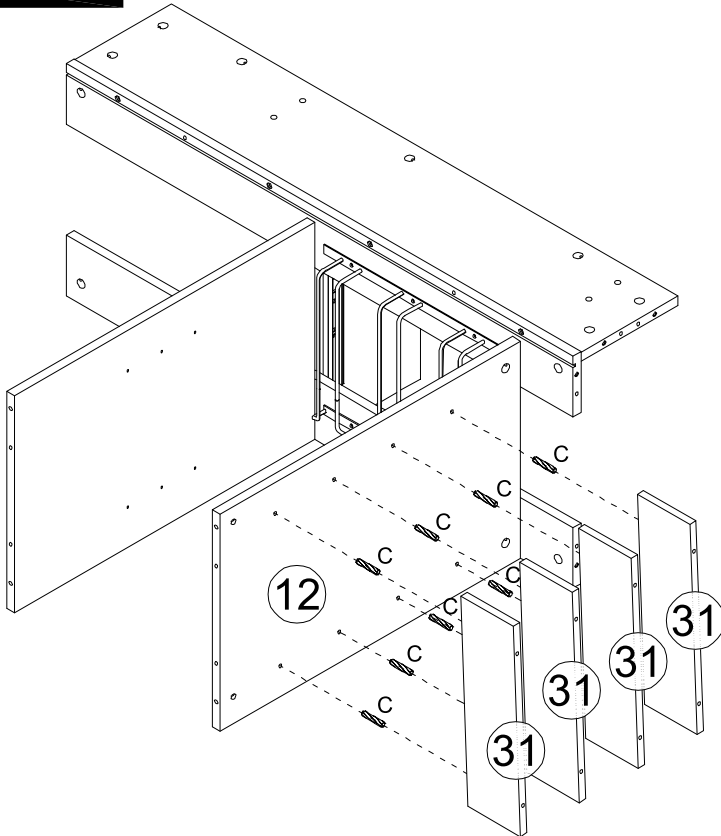

# Assembly Instruction Montageanleitung

ITEM:N635P337195& N635P337198

## Step 11

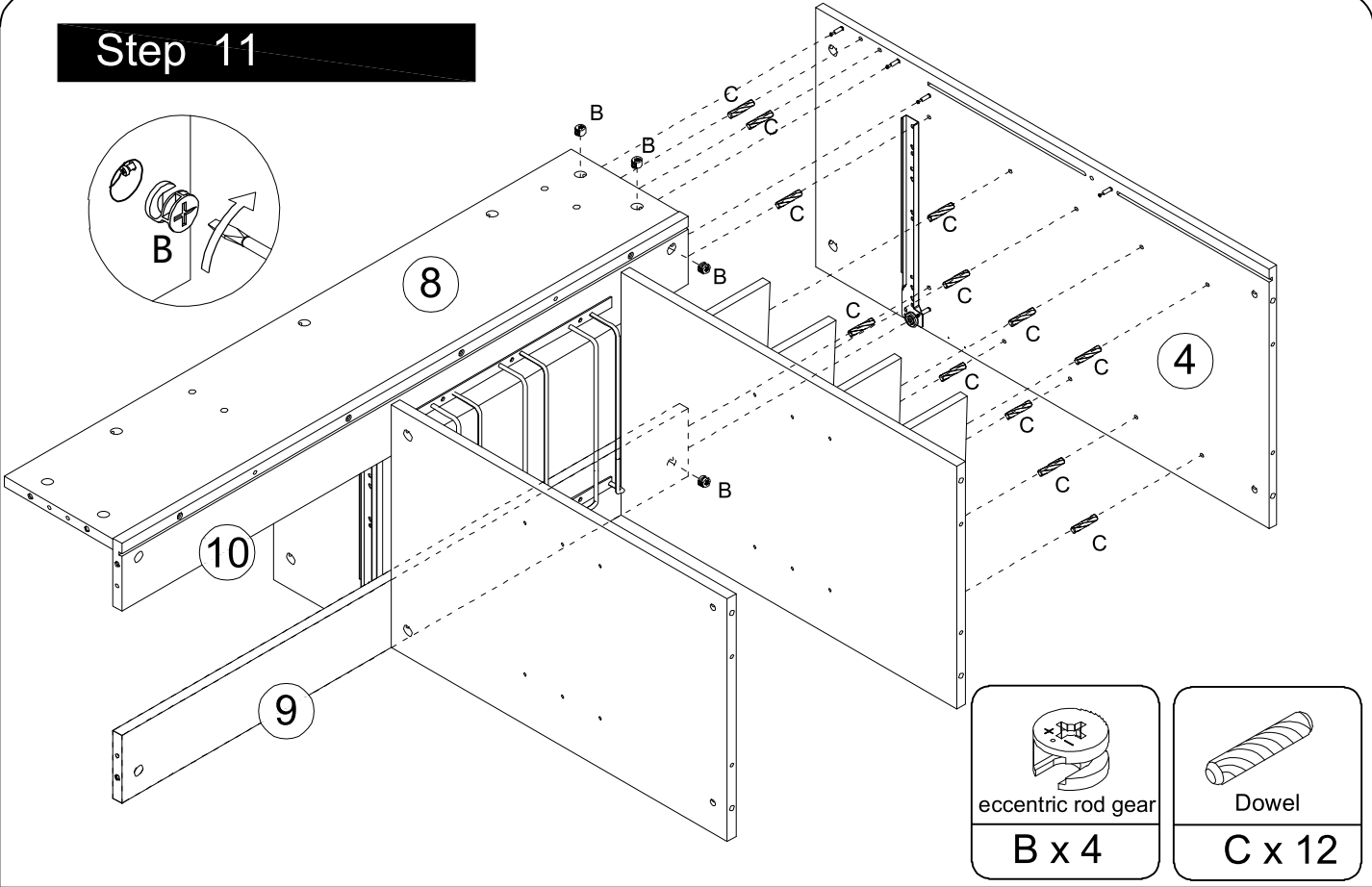

## Step 12

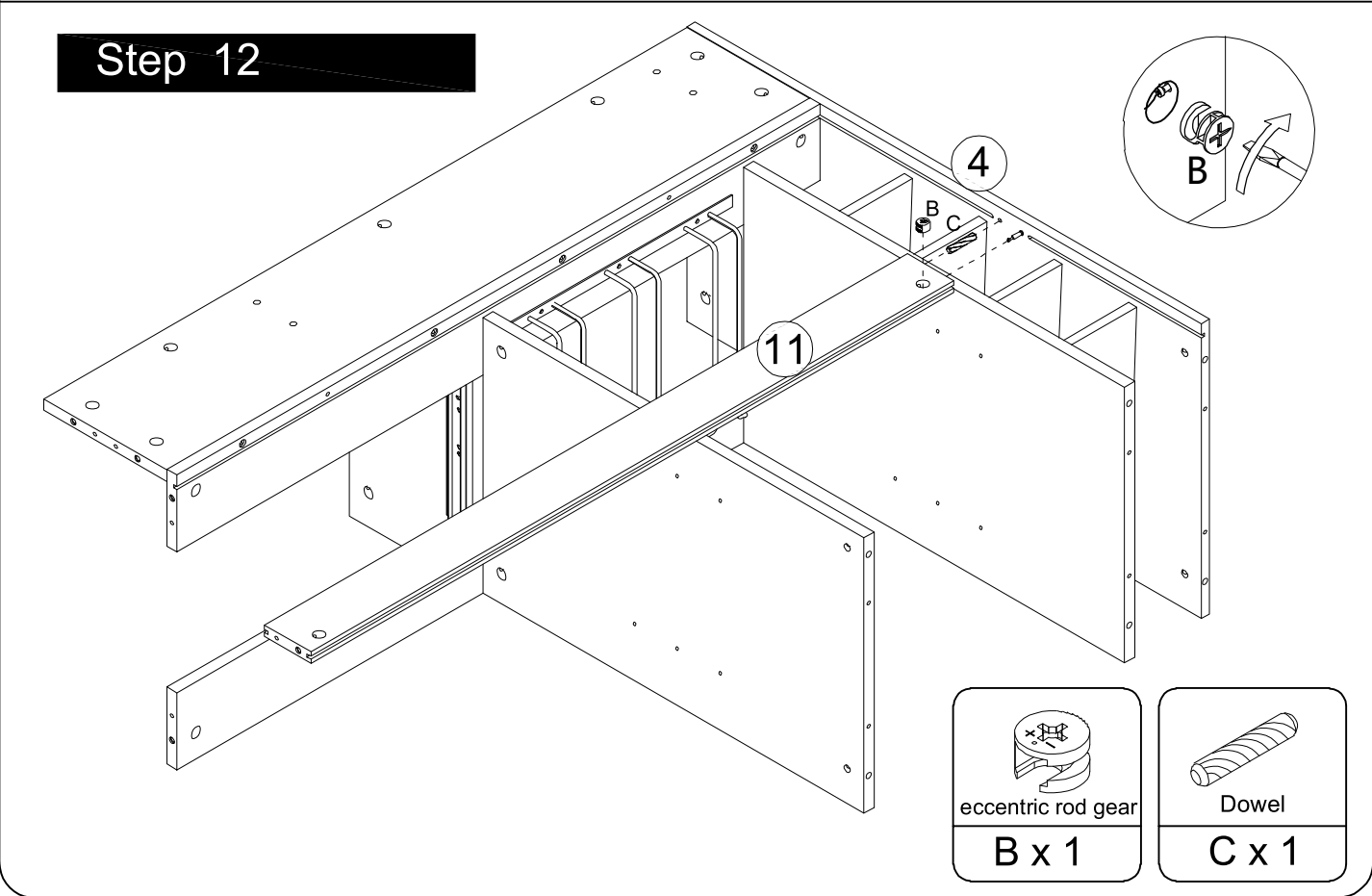

# Assembly Instruction Montageanleitung

## ITEM:N635P337195& N635P337198

### Step 13

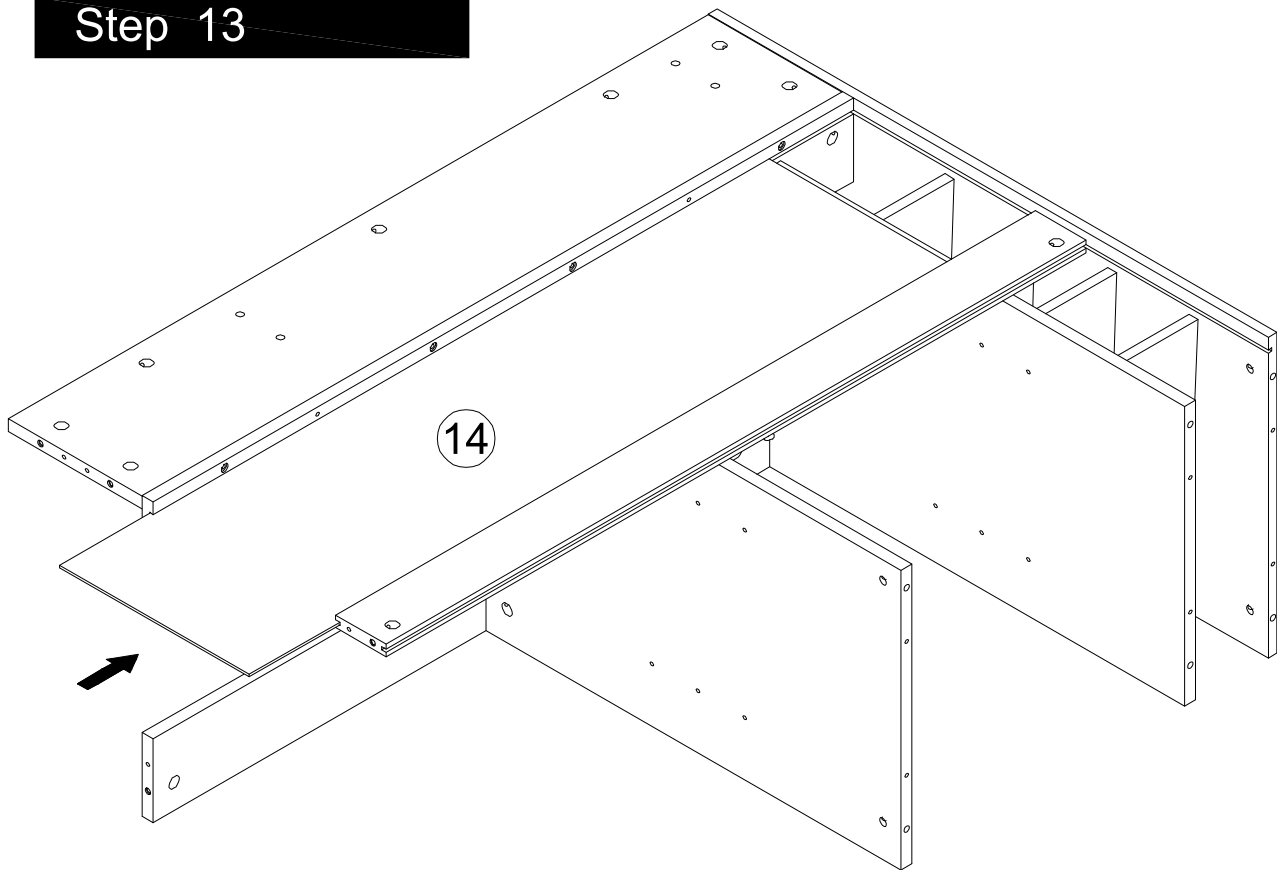

### Step 14

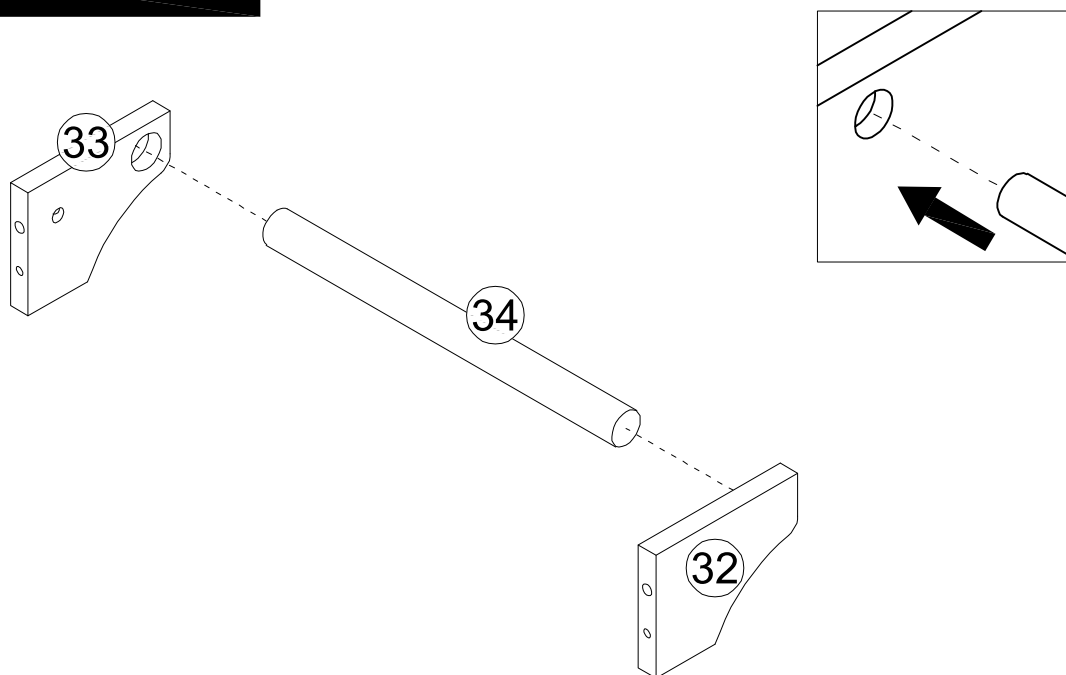

# Assembly Instruction Montageanleitung

ITEM:N635P337195& N635P337198

## Step 15

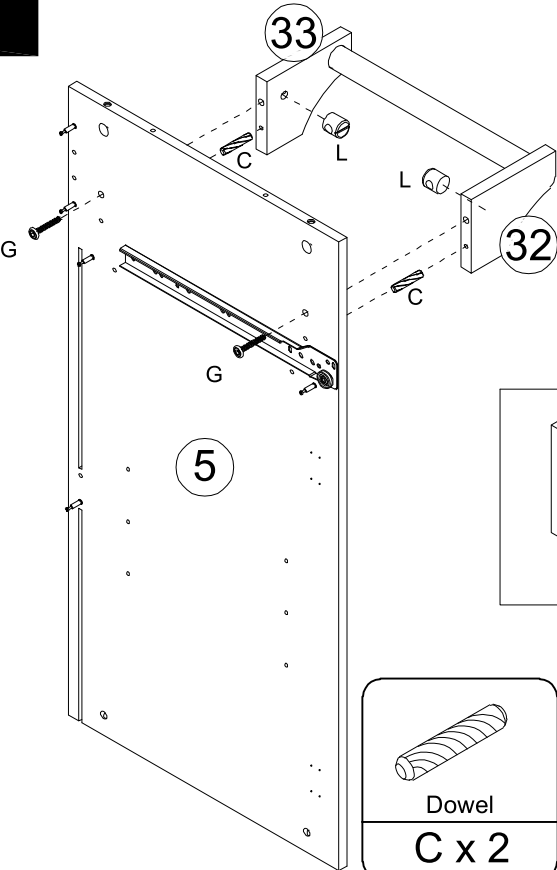

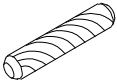

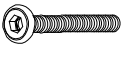
Dowel
<b>C x 2</b>

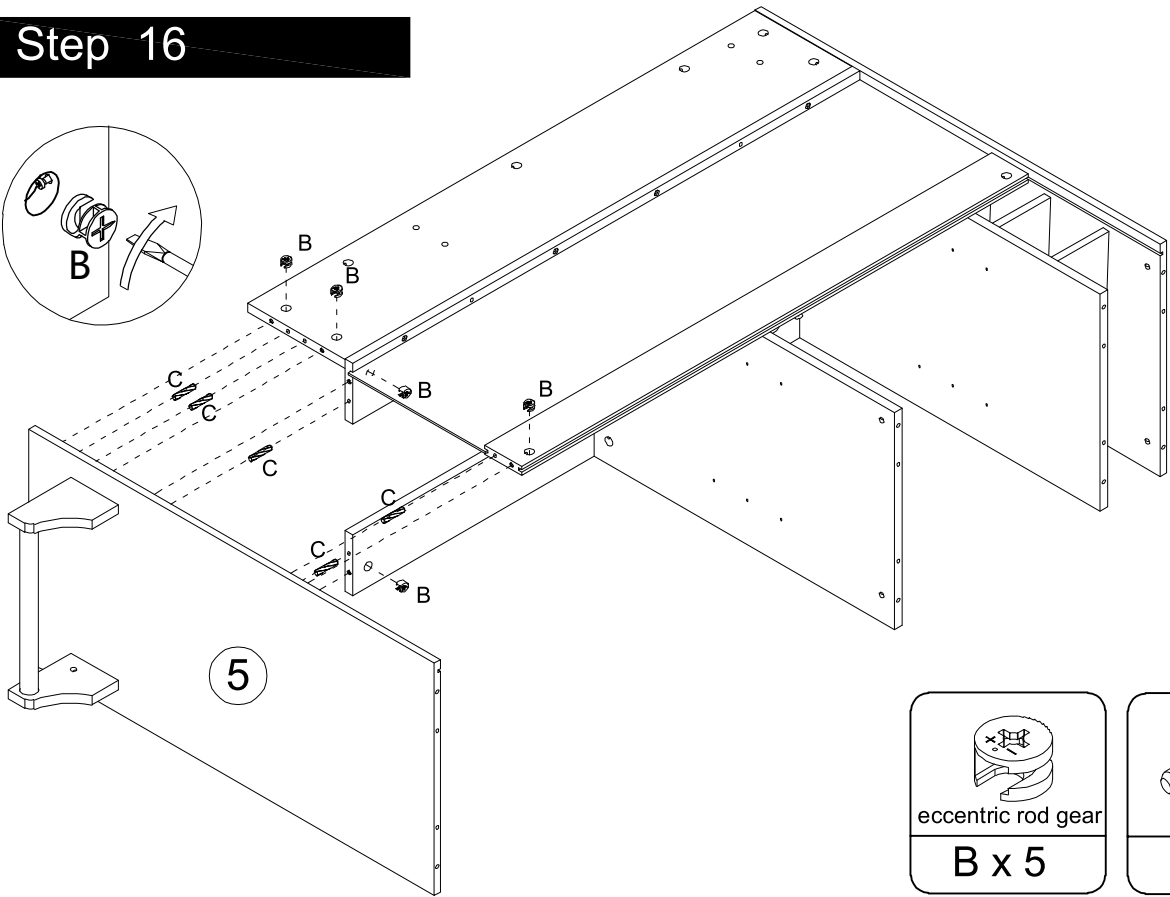

Bolt
<b>G x 2</b>

T nut
<b>L x 2</b>

## Step 16



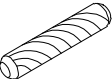

eccentric rod gear
<b>B x 5</b>

Dowel
<b>C x 5</b>

# Assembly Instruction Montageanleitung

## ITEM:N635P337195& N635P337198

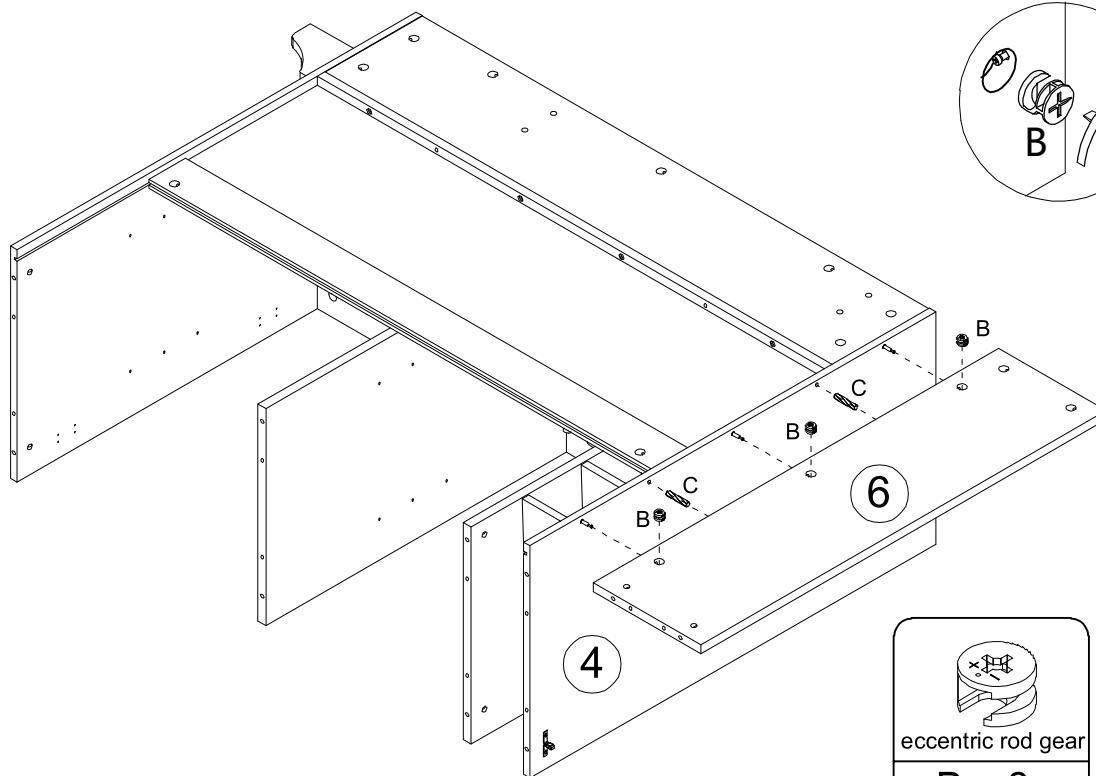
### Step 17



### Step 18

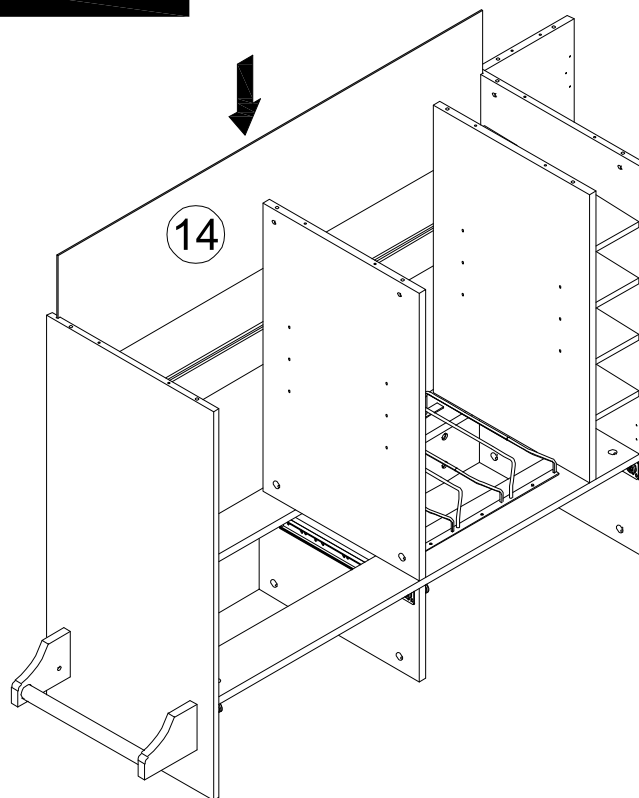

# Assembly Instruction Montageanleitung

ITEM:N635P337195& N635P337198

## Step 19

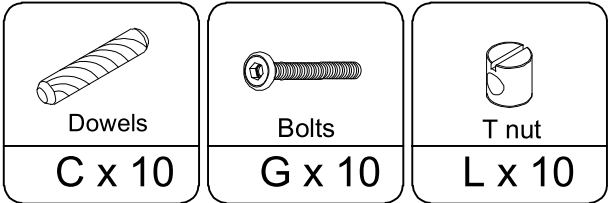
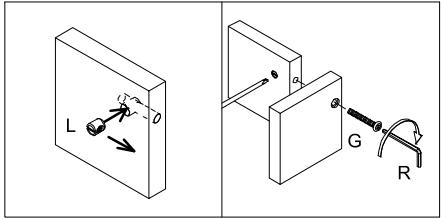
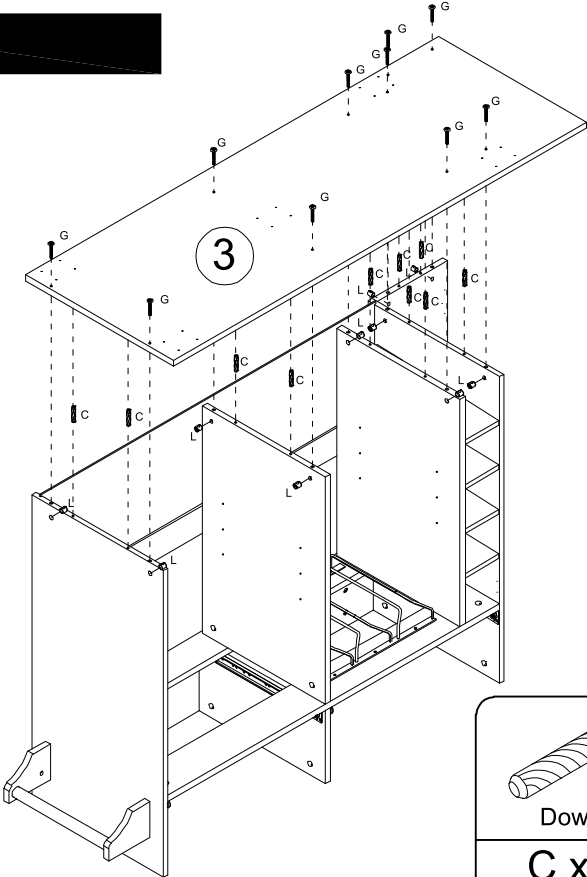

## Step 20

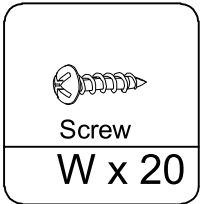
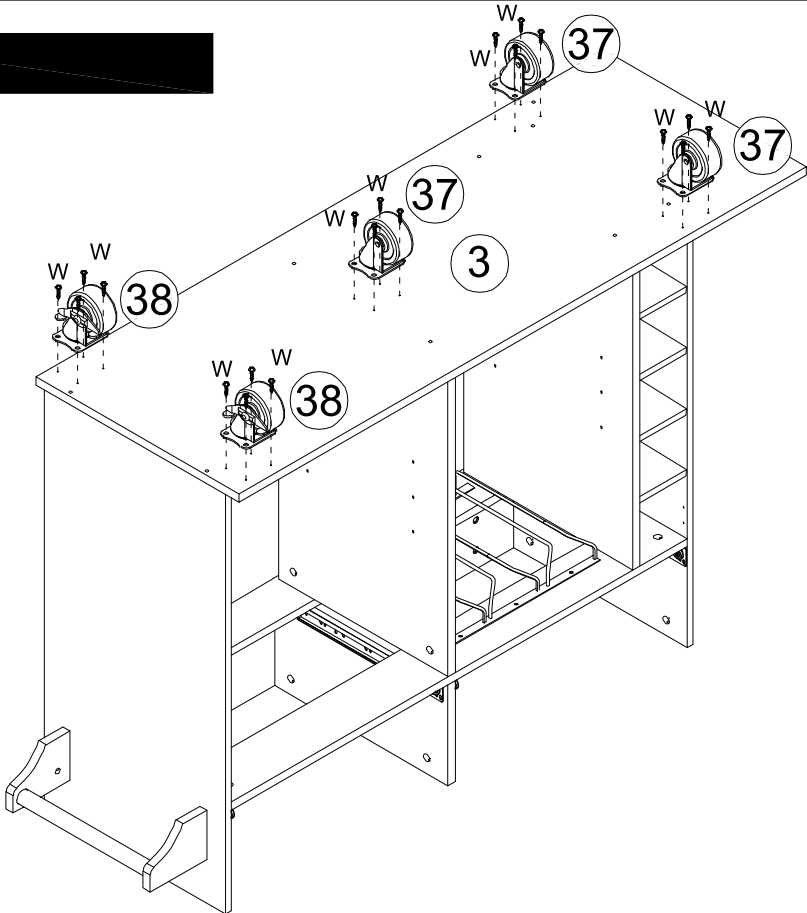

# Assembly Instruction Montageanleitung

ITEM:N635P337195& N635P337198

## Step 21

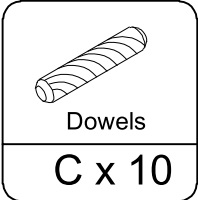
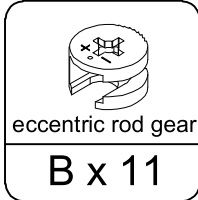
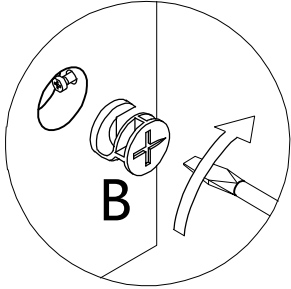
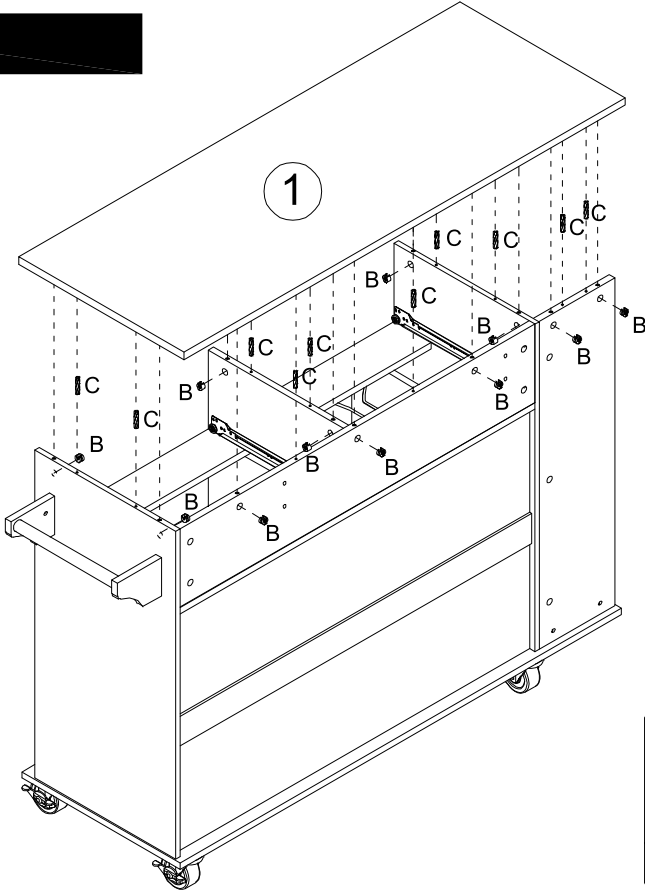

## Step 22

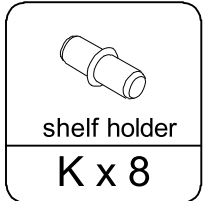
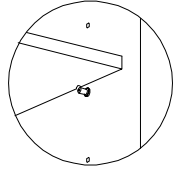
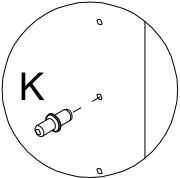
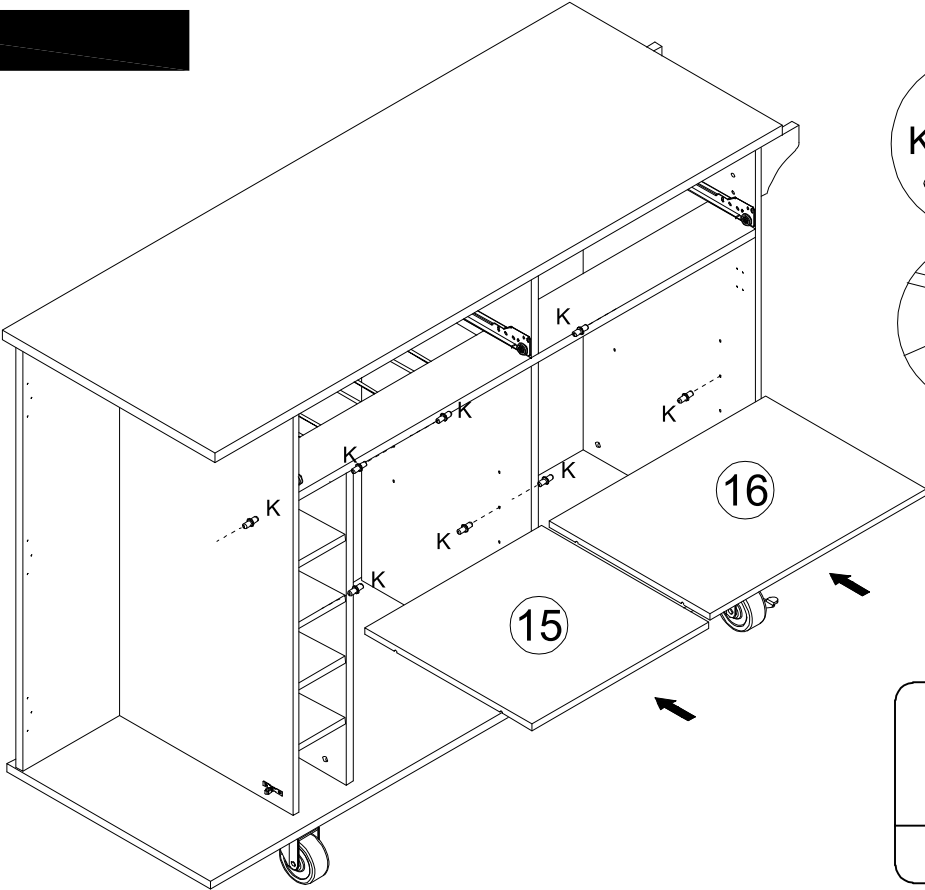



# Assembly Instruction Montageanleitung

ITEM:N635P337195& N635P337198

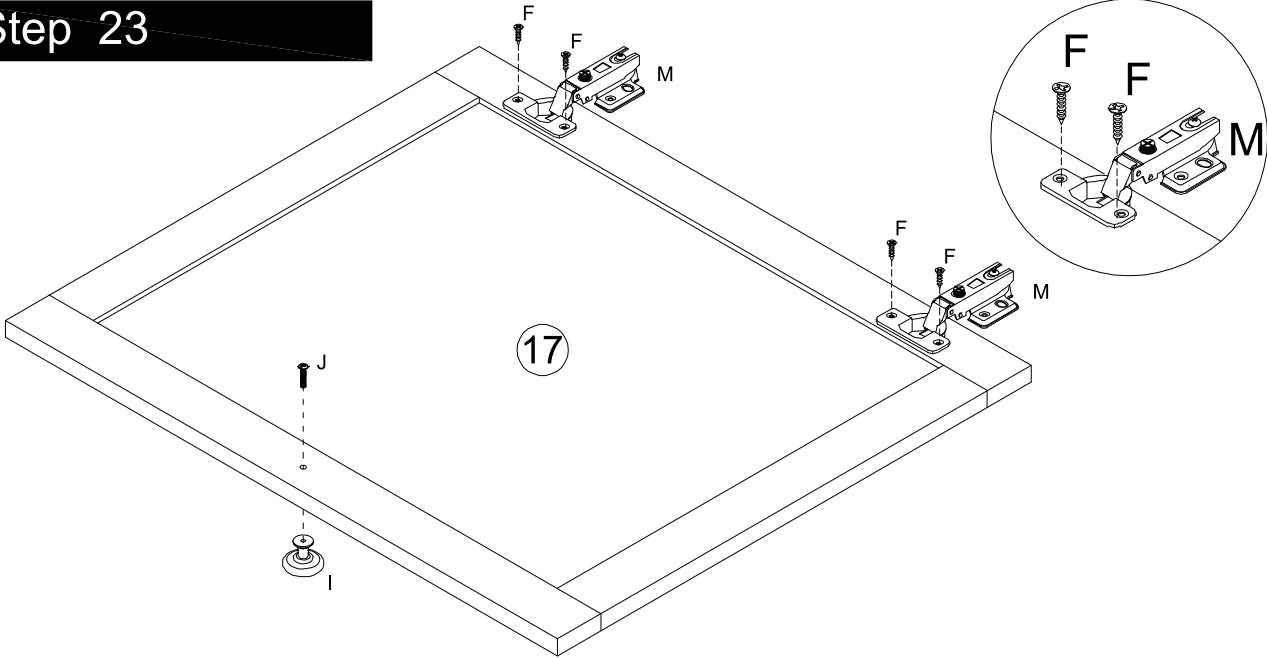
## Step 23

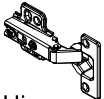

			
Screw	Knob	Bolt	Hinge
F x 4	I x 1	J x 1	M x 2

## Step 24

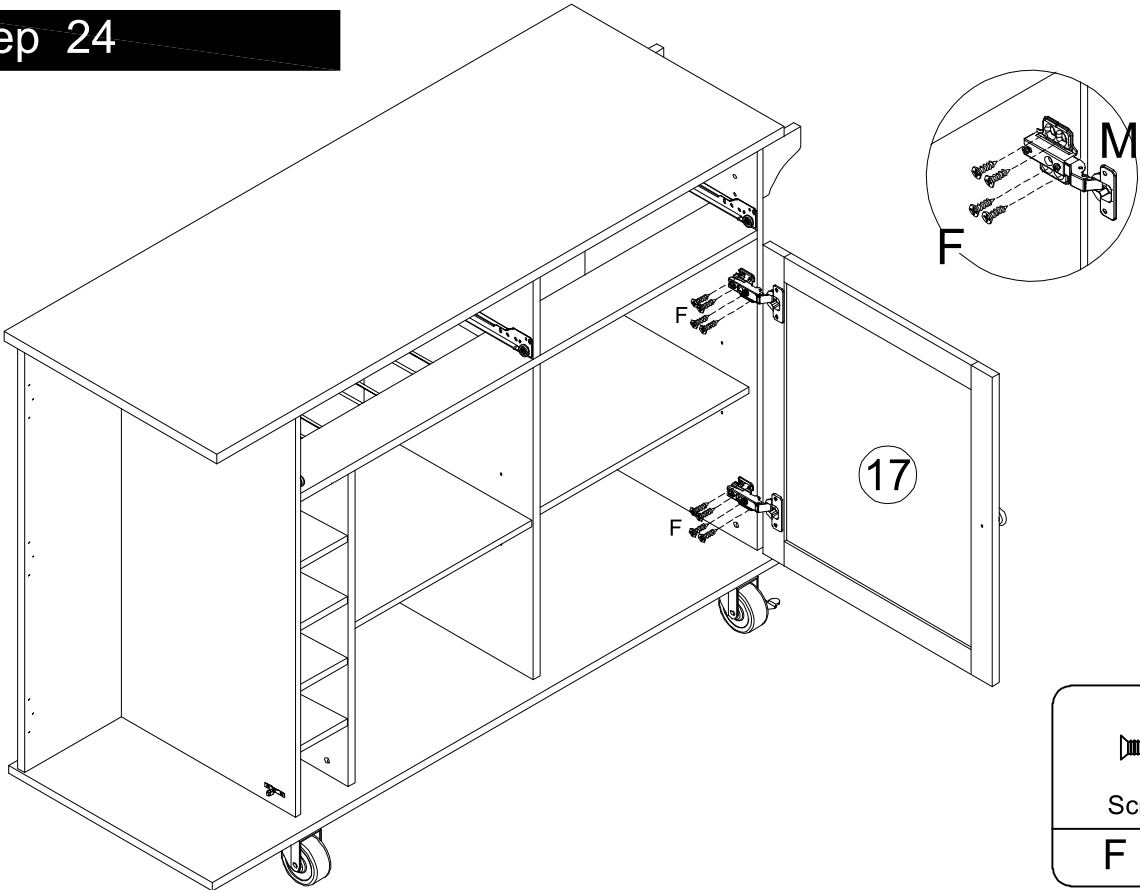



Screw
F x 8

# Assembly Instruction Montageanleitung



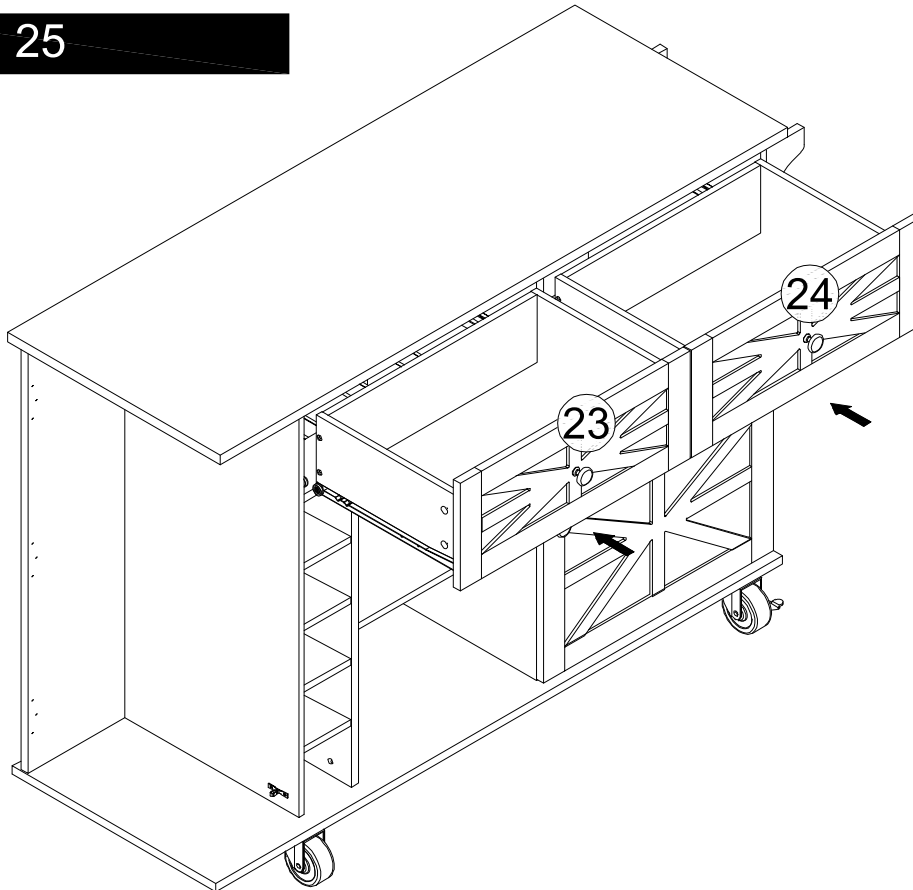

## ITEM:N635P337195& N635P337198

### Step 25

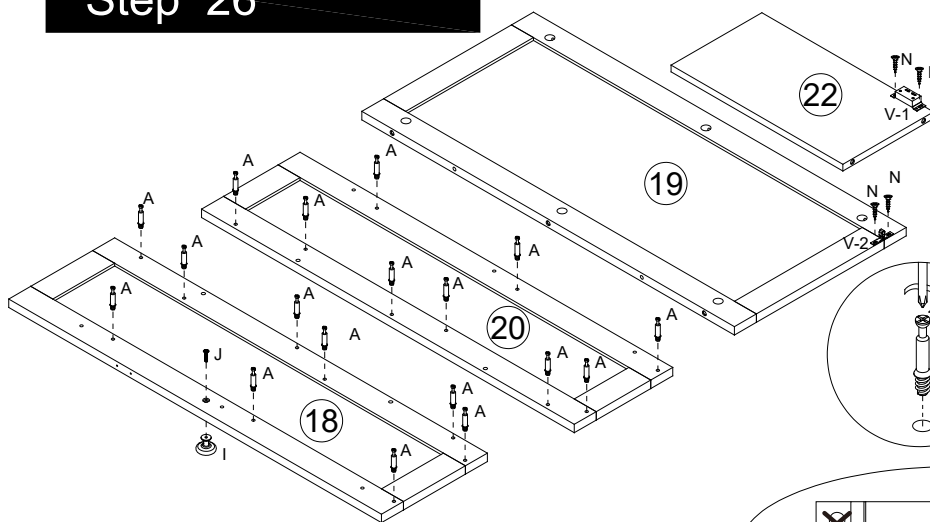

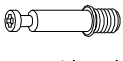
### Step 26

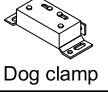

 eccentric rod A x 18	 Knob I x 1	 Bolts J x 1
 V-2 x 1	 eccentric rod N x 4	 Dog clamp V-1 x 1

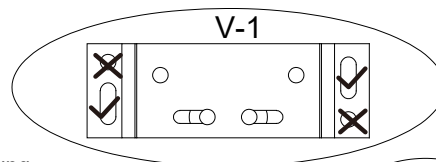
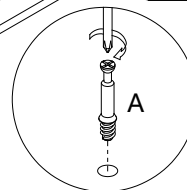

**Step 26.1** Secure V-1 with 2 Screws(N) on the Top Panel.  
Make sure that two mounting positions are both present in the elliptical holes, and make sure the mounting positions are aligned.  
Schritt 26.1 Befestigen Sie V-1 mit 2 Schrauben (N) an der oberen Abdeckung.  
Stellen Sie sicher, dass beide Befestigungspunkte in den elliptischen Löchern vorhanden sind und dass die Befestigungspunkte ausgerichtet sind.

**Step 26.2** If no stuck are found, proceed to tighten both of the Screws.  
Ensure that the position of V-1 and V2 are aligned and locked properly  
Ensure that V-1 and V-2 can be turned on and off smoothly.  
Schritt 26.2 Wenn keine Blockierungen festgestellt werden, ziehen Sie beide Schrauben fest.  
Stellen Sie sicher, dass die Positionen von V-1 und V-2 ausgerichtet und ordnungsgemäß arretiert sind.  
Stellen Sie sicher, dass V-1 und V-2 reibungslos ein- und ausgeschaltet werden können.

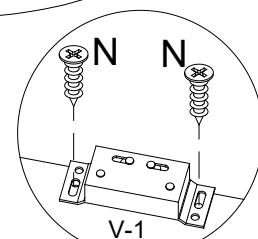

# Assembly Instruction Montageanleitung

## ITEM:N635P337195& N635P337198

### Step 27

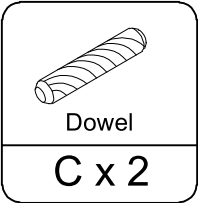
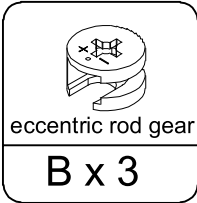
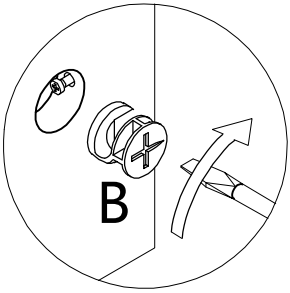
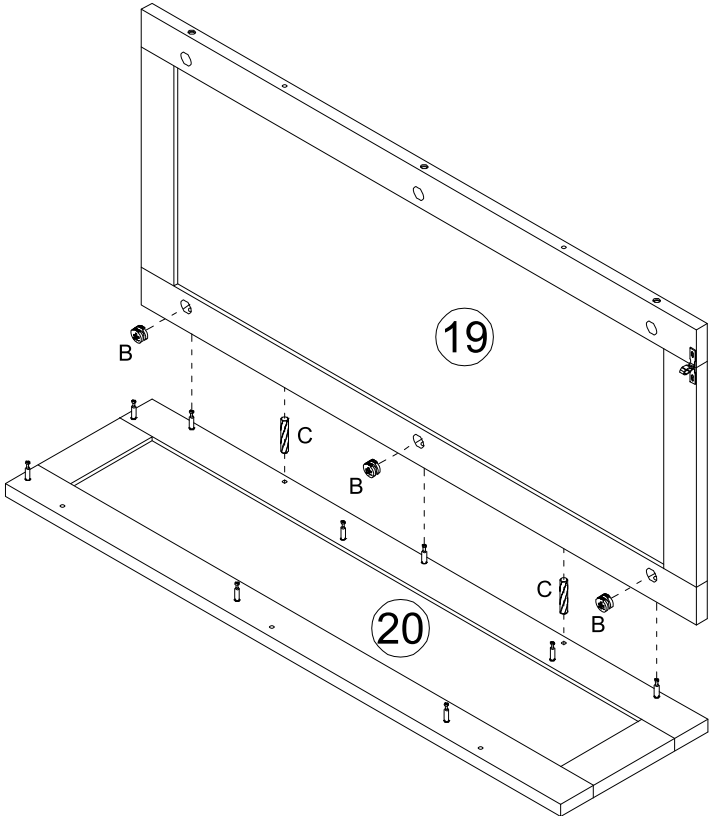

### Step 28

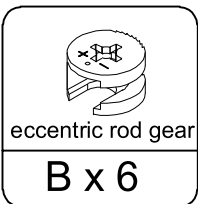
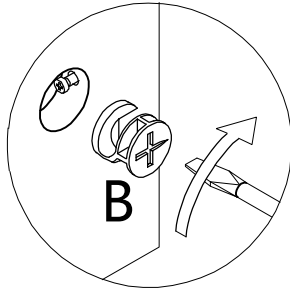
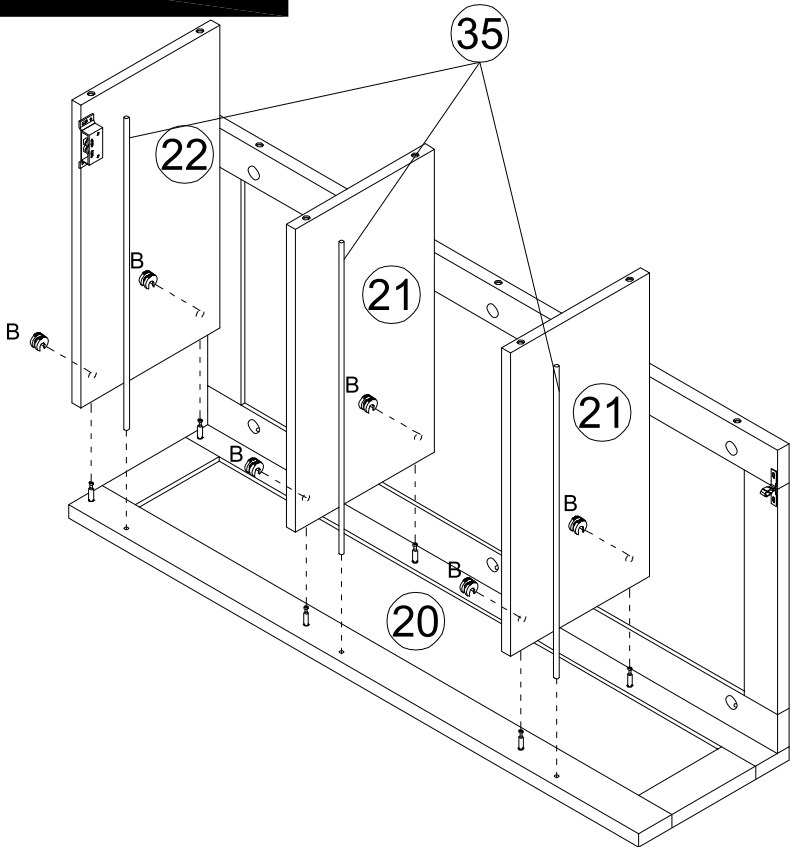

# Assembly Instruction Montageanleitung

ITEM:N635P337195& N635P337198

## Step 29

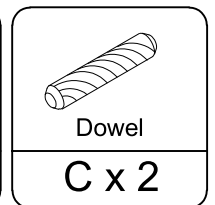
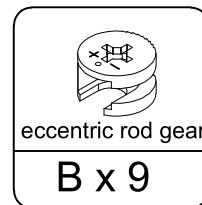
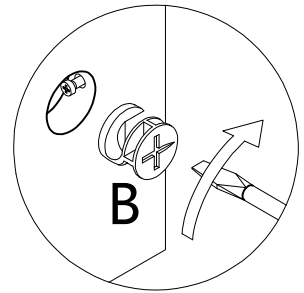
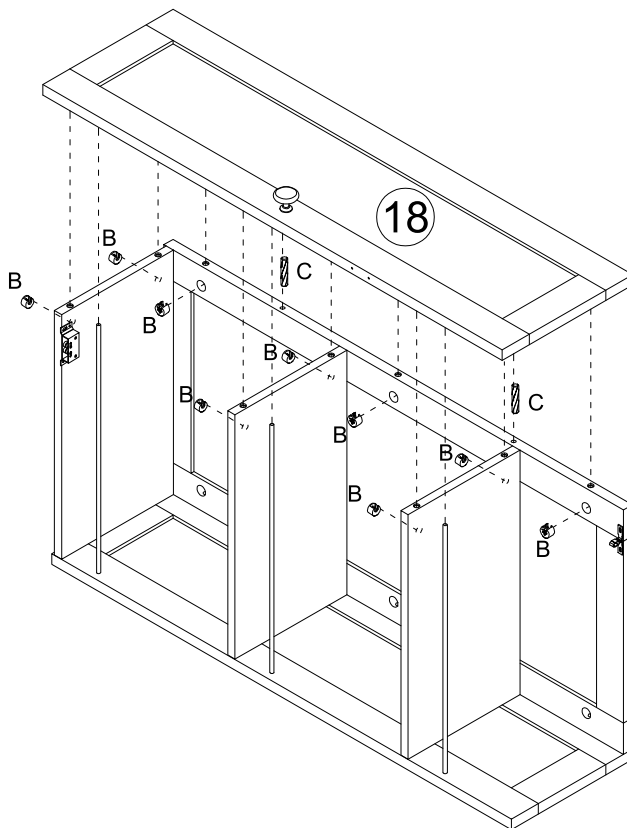

## Step 30

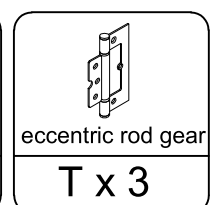
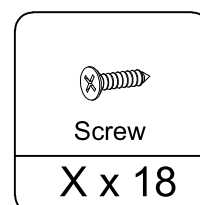
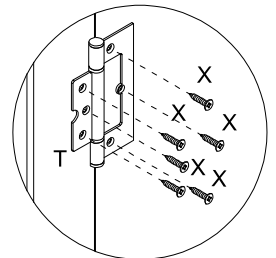
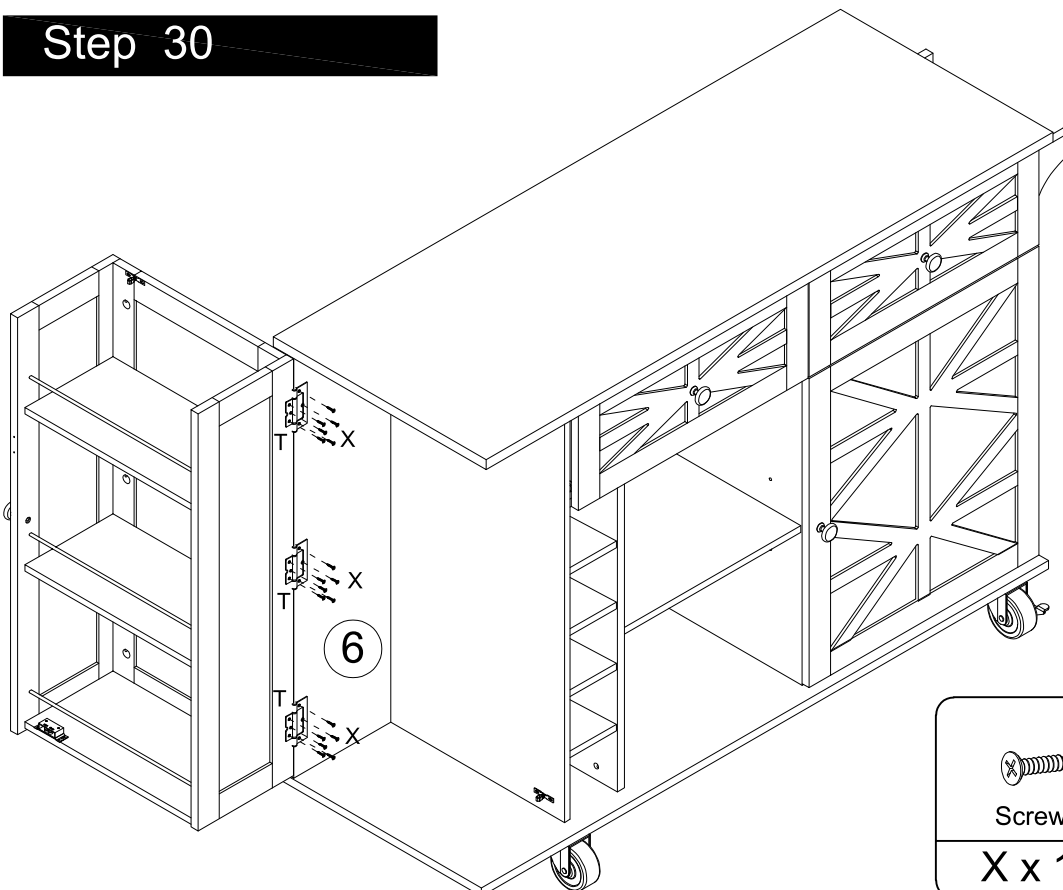

# Assembly Instruction Montageanleitung

## ITEM:N635P337195& N635P337198

### Step 31

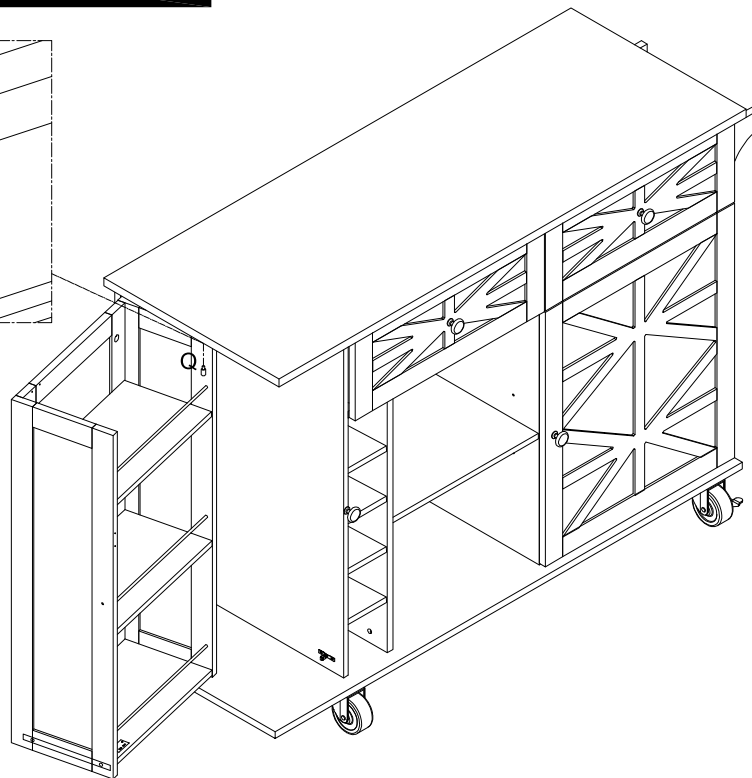
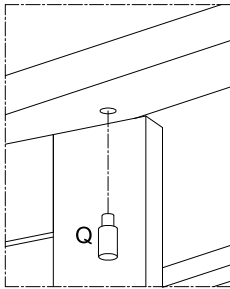

Stop bolt

Q x 1

### Step 32

Part U lock catch can be optionally installed.  
If this product needs to be moved on uneven ground,  
we recommend installing this lock catch.  
When fastened, it can be locked more securely.

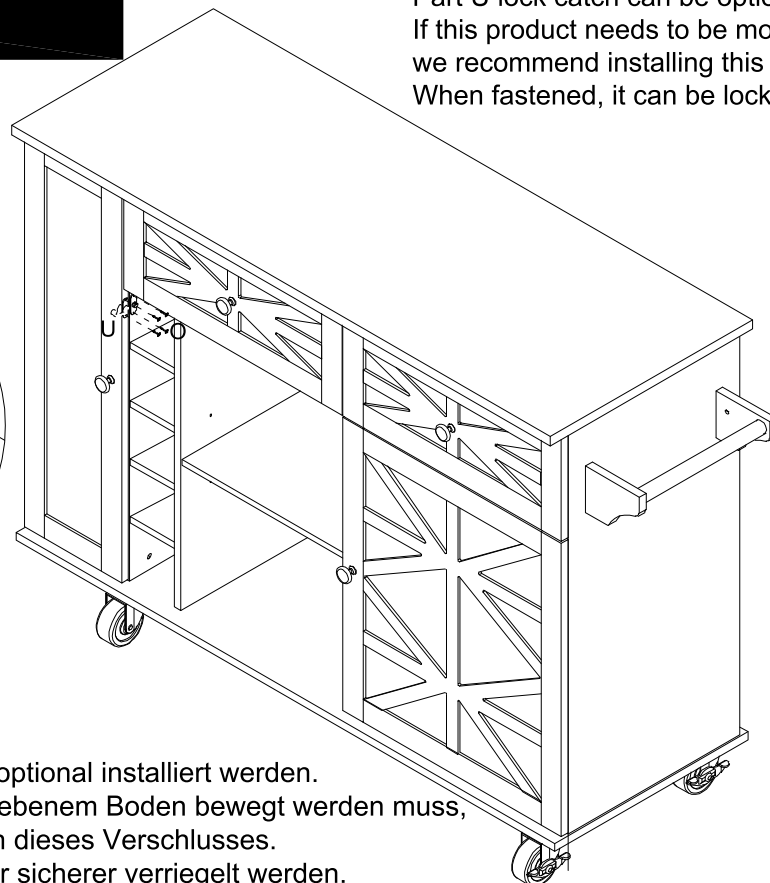
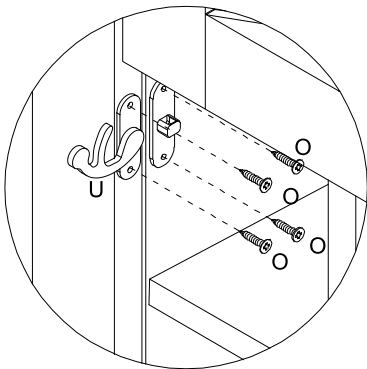

Lock catch

U x 1



Screw

O x 4

Der Teil-U-Verschluss kann optional installiert werden.  
Wenn dieses Produkt auf unebenem Boden bewegt werden muss,  
empfehlen wir die Installation dieses Verschlusses.  
Wenn er befestigt ist, kann er sicherer verriegelt werden.

# Assembly Instruction Montageanleitung

ITEM:N635P337195& N635P337198

## Step 33

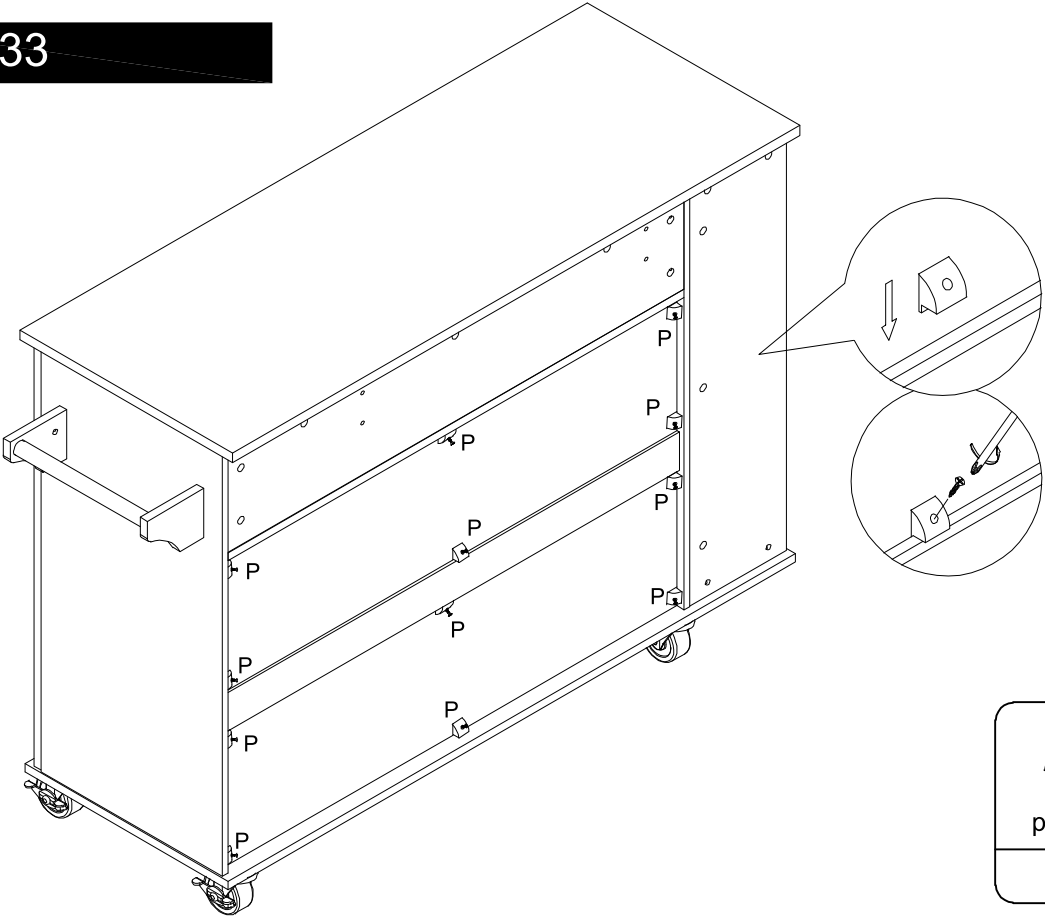

## Step 34

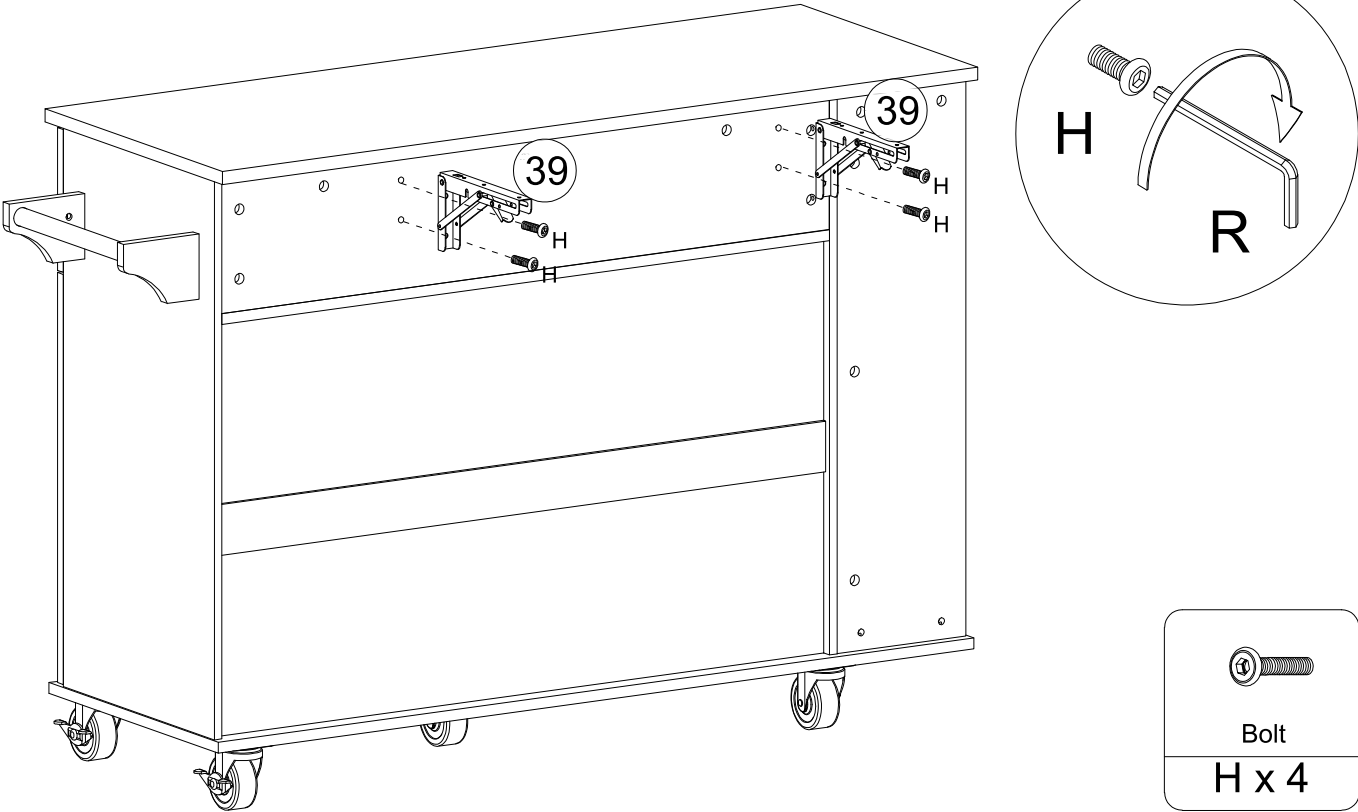

# Assembly Instruction Montageanleitung

ITEM:N635P337195& N635P337198

## Step 35

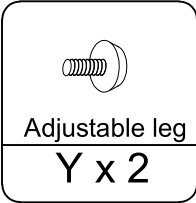
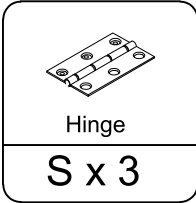
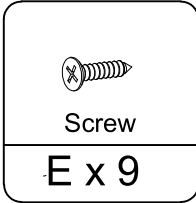
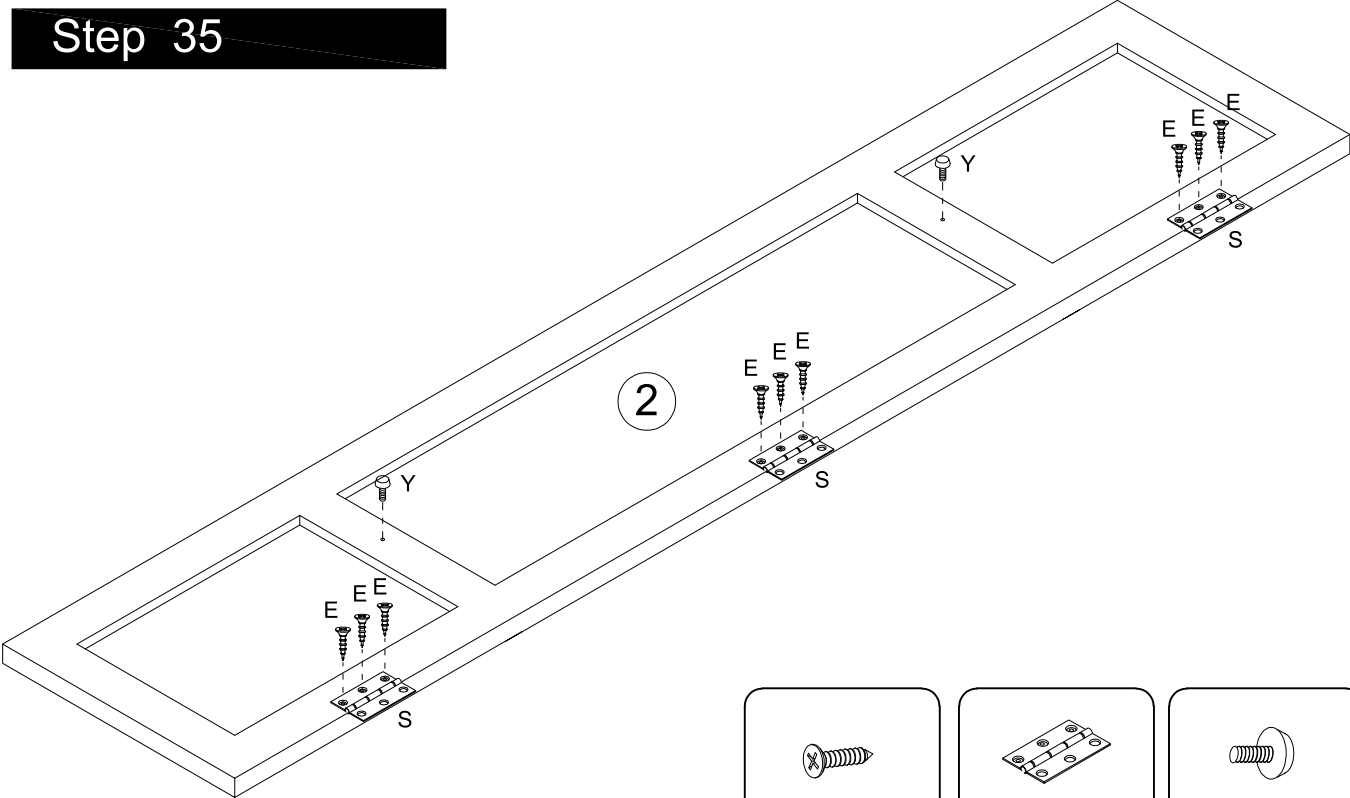

## Step 36

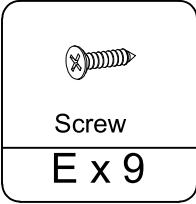
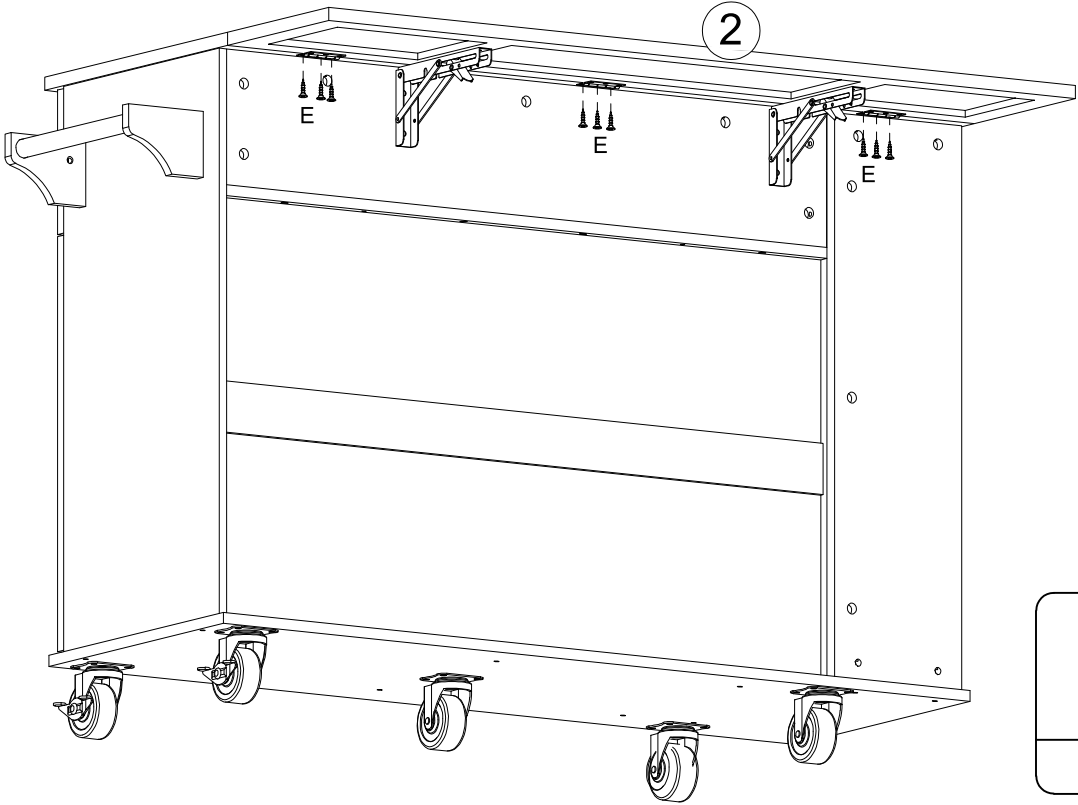

# Assembly Instruction Montageanleitung

ITEM:N635P337195& N635P337198

## Step 37

