

Wall Light

INSTRUCTION MANUAL

Safety Warnings

- This product is only suitable for connection to a 240V~50Hz supply in accordance with current IEE wiring Regulations. It should be installed in accordance with local building regulations and is for domestic ceiling use only. It is not suitable for a bathroom location.
- Before installing your light fitting always switch off the mains supply and remove the appropriate fuse or switch off the appropriate circuit breaker before commencing installation.
- This is a Class I Fitting, and **must** be Earthed. The terminal blocks are supplied according to requirements of the fitting.
- Never fit bulbs of a higher wattage than those specified on the label (as these may cause overheating and damage the fitting).
- If you are in any doubt about your competence please consult a qualified electrician.
- If any modification is made it will invalidate the warranty and may render the product unsafe.

Care Information

Allow 10 minutes to cool before replacing, adjusting or cleaning.
Clean with a dry cloth only. Do not use liquid or abrasive cleaners on this product.

Assembly/ User Instructions

Before you start

Please read these instructions carefully before fitting and retain for reference. Check the packaging and make sure that you have all the required parts. Follow each assembly step in order to prevent incorrect assembly. Ensure that the product is fully assembled as illustrated before use.

The Light pack contains:

Light fitting.
Terminal connection block(s).
Fixing pack.

The following tools may be required:

Selection of cross and flat head screwdrivers.
Electric drill and assorted drill bits.
Wire strippers.
Electrical insulation tape.

These assembly diagrams are intended as a guide – if in doubt consult a qualified electrician.

1. Decide on the position of the light fitting / or remove existing light fitting. Take a note of the position of the electrical connections. Ensure there is a solid mounting surface, preferably a wooden joist or joist bridge to support the weight of the light fitting.
2. Remove the two side screws (4) and retain the screws for re-use. Use the fixing bracket as a template to mark the screw holes. Mark the screw holes and secure to the wall with appropriate screw fixings (1&2), making sure the bracket is horizontal.
3. Support your fitting and connect the house wiring to the terminal block (3). When you are sure of the connections wrap the Terminal Block and overlap the wiring both sides with 2 layers of insulation tape.
NOTE: This is a Class I fitting and must be earthed.
4. Secure the backplate over the bracket by using the screws (4) removed in Point 2.
5. Fit the bulb(s) (7). **NOTE: Never fit bulbs of a higher wattage than those specified on the label (as these may cause overheating and damage the fitting).**
6. Fit the shade (5) by slotting over the screw thread, and securing in place with the decorative screw cap (6).
7. Turn on the power and test.



Assembly/ User Instructions Continued

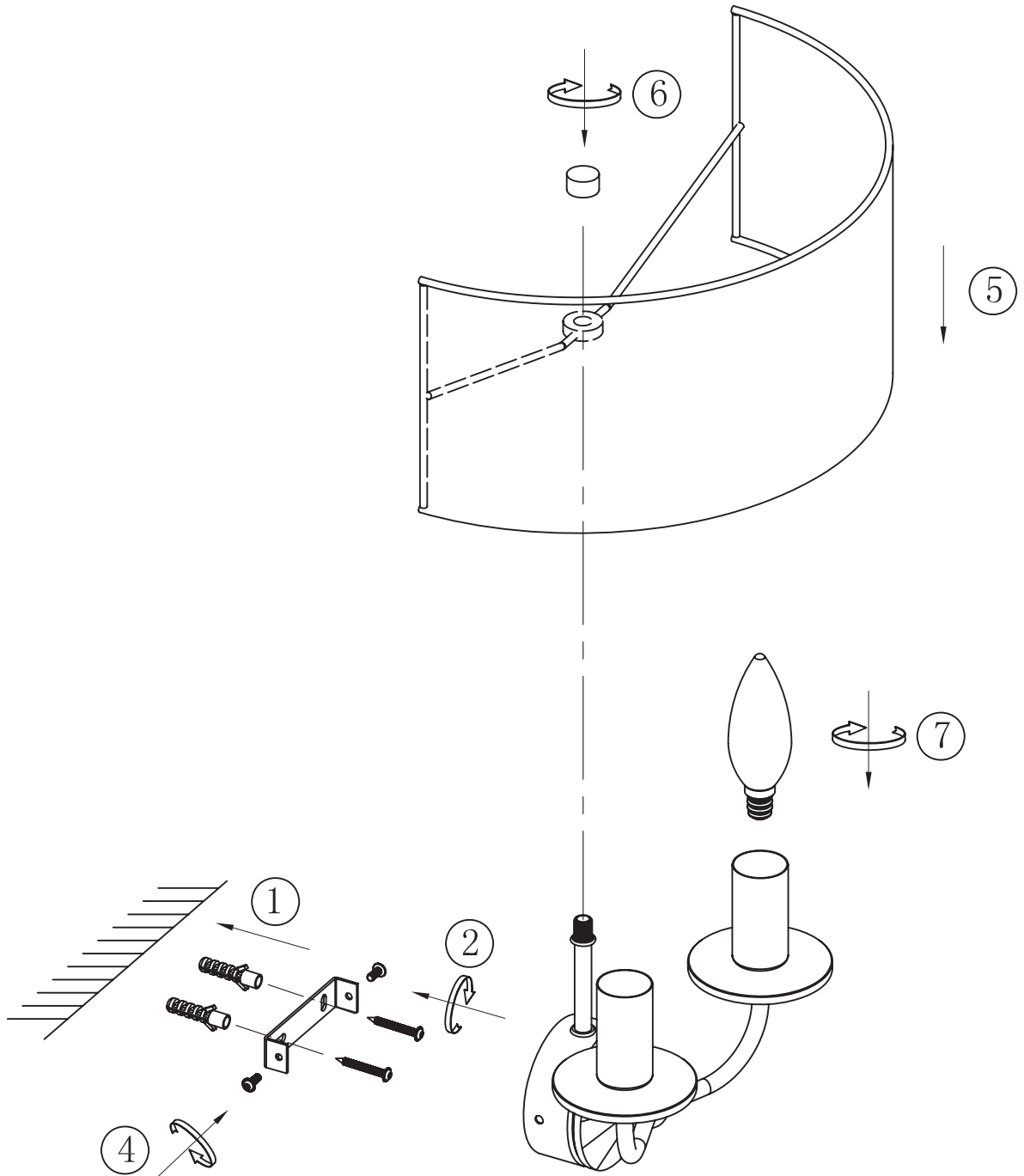

LOOP (UK ONLY) = [Diagram of a loop terminal] = LOOP (UK ONLY) (3)

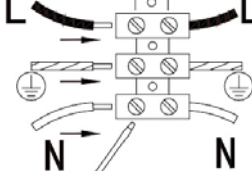

GB-IE L= Brown or Red L= Marron ou Rouge ou Noir
 N= Blue or Black N= Bleu
 ⊕ = Green / Yellow ⊕ = Vert/Jaune

DE L= Braun oder Rot oder Schwarz
 N= Blau
 ⊕ = Grün/Gelb

