

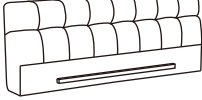

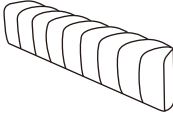

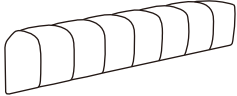



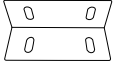

# ASSEMBLY INSTRUCTIONS

## Components

<b>A</b>		<b>Head board</b>	<b>1</b>
<b>B</b>		<b>Side board</b>	<b>2</b>
<b>C</b>		<b>Foot board</b>	<b>1</b>
<b>D</b>		<b>Bed slat</b>	<b>1</b>
<b>E</b>		<b>Connector</b>	<b>4</b>
<b>F</b>		<b>Leg</b>	<b>8</b>
<b>G</b>		<b>Middle leg</b>	<b>2</b>

## Hardware

<b>a</b>		<b>Washer</b>	<b>28</b>
<b>b</b>		<b>Screw</b>	<b>28</b>
<b>c</b>		<b>Spanner</b>	<b>1</b>
<b>d</b>		<b>Screw</b>	<b>4</b>
<b>e</b>		<b>Bolt</b>	<b>4</b>

# ASSEMBLY STEPS

## STEP 1

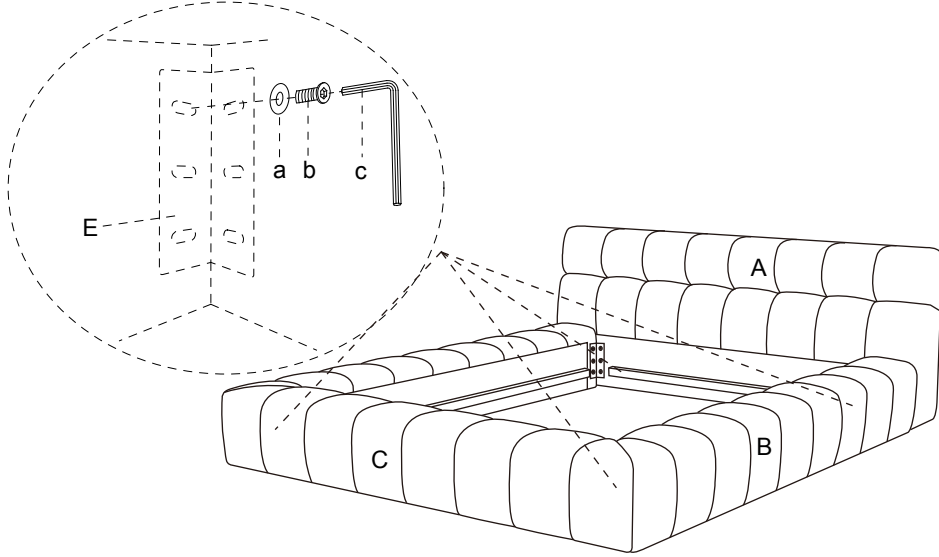

## STEP 2

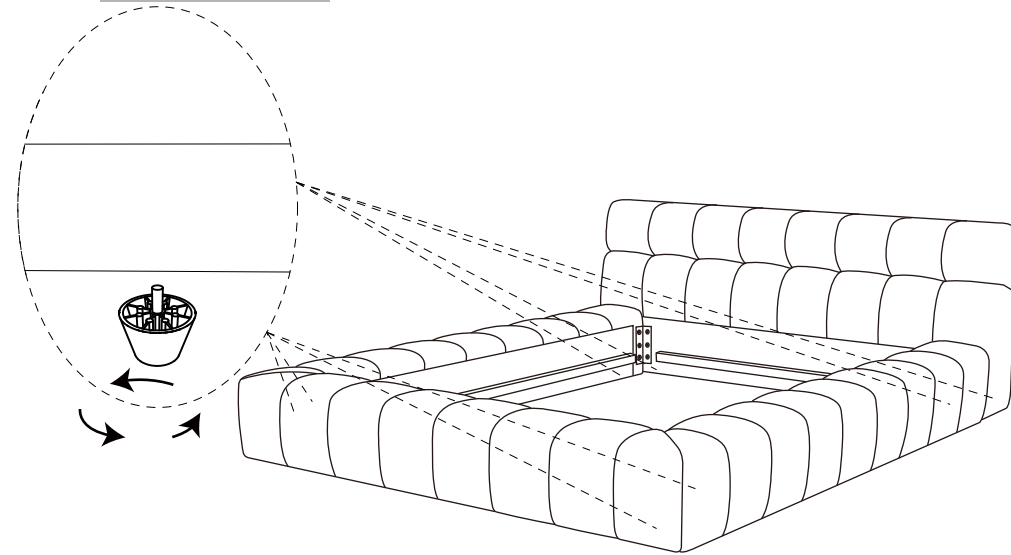

A SCREWDRIVER IS REQUIRED TO ASSEMBLE THE LEGS.

## STEP 3

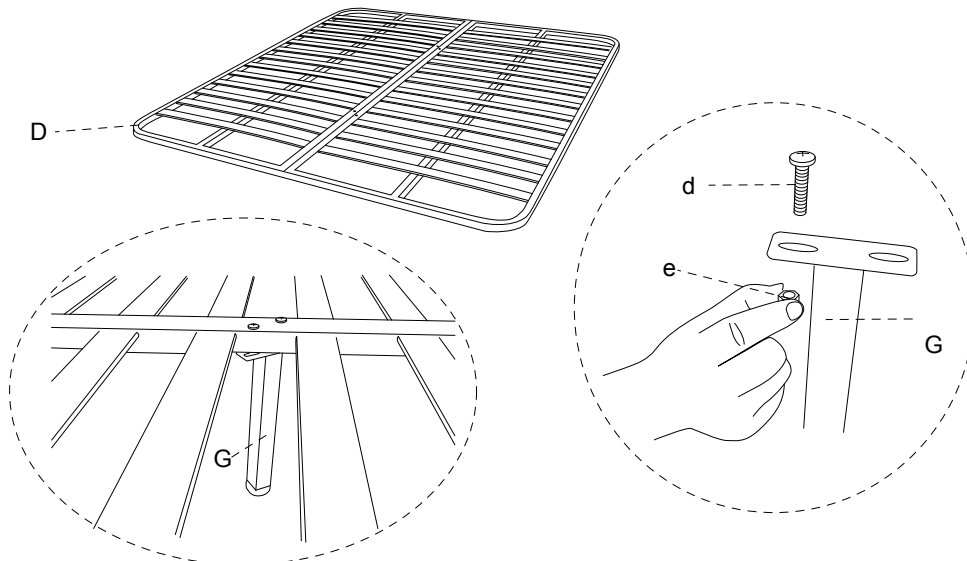

A SCREWDRIVER IS REQUIRED TO ASSEMBLE THE LEGS.

## STEP 4

