

ASSEMBLY INSTRUCTIONS

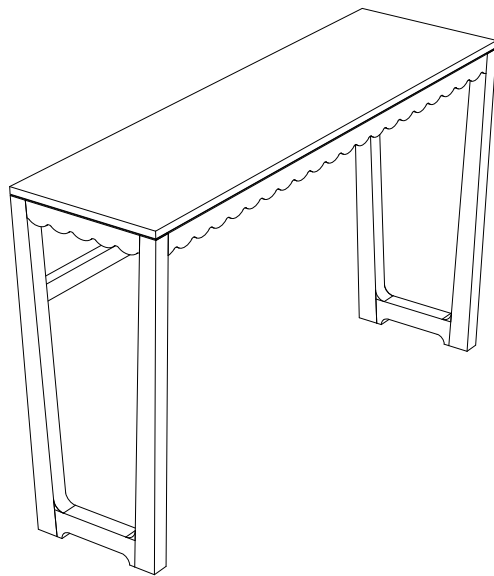

Contour Scalloped Console Table

BOX COMPONENTS

(A)

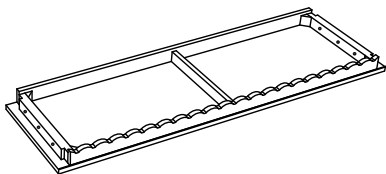

Top Structure | 1 piece

(B)

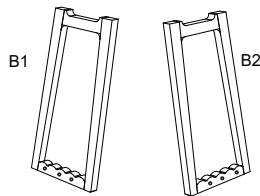

Legs | 2 pieces

(C)



Mid-support | 1 pieces

(D)

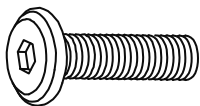

Allen Bolt | 8 x 40 mm
8 pieces

(E)

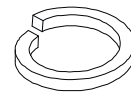

Lock Washer | 8 x 16 mm
8 pieces

(F)



Flat Washer | 8 x 18 mm
8 pieces

(G)

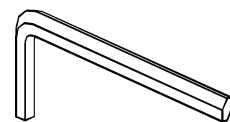

Allen Key | 5 mm
1 pieces

FOLLOW THE GIVEN STEP-BY-STEP PROCESS TO ASSEMBLE

STEP
01

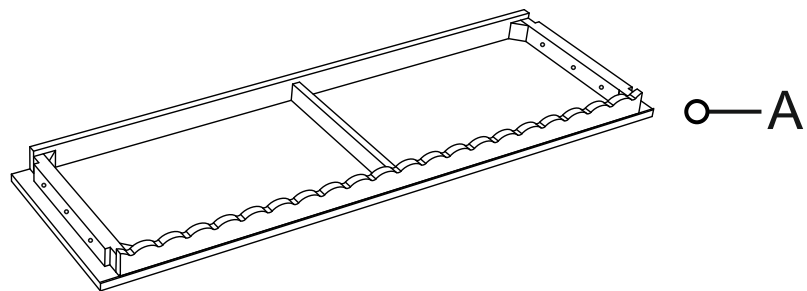

Place the top structure (A) upside down on level surface.

STEP
02

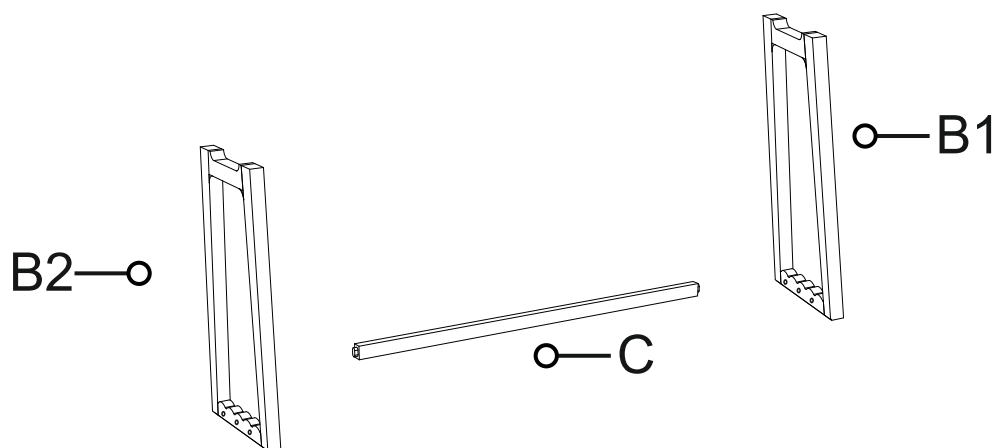

Place legs (B1&B2) in Mid-support (C) as show in
the reference picture.

FOLLOW THE GIVEN STEP-BY-STEP PROCESS TO ASSEMBLE

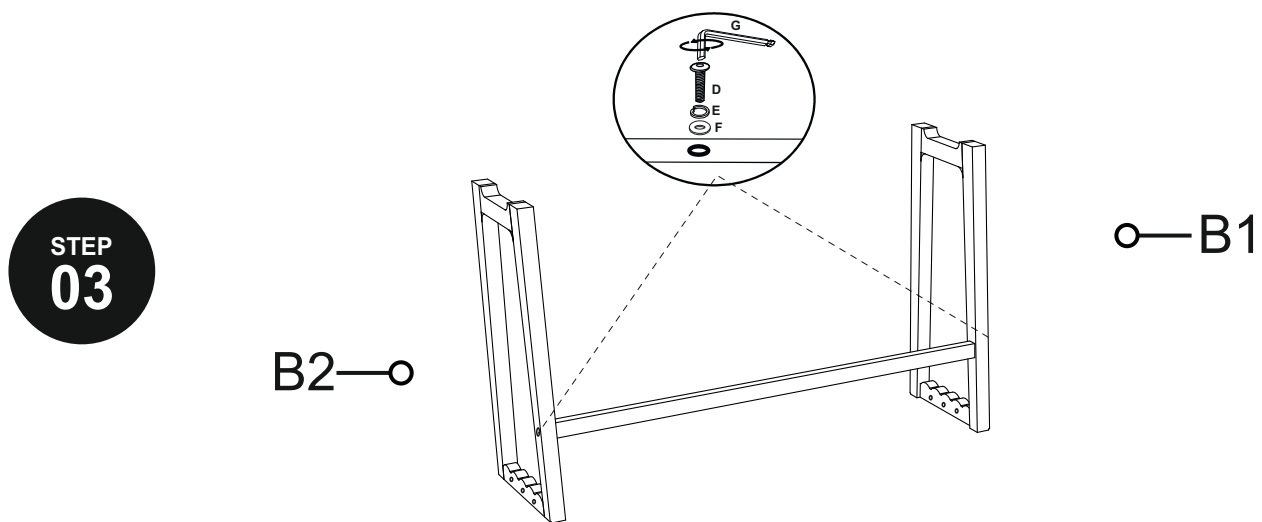

Using key (G) tighten bolt (D), lock washer (E) and flat washer (F) to tighten the top frame (A) and legs (B1&B2) as show in the reference picture.

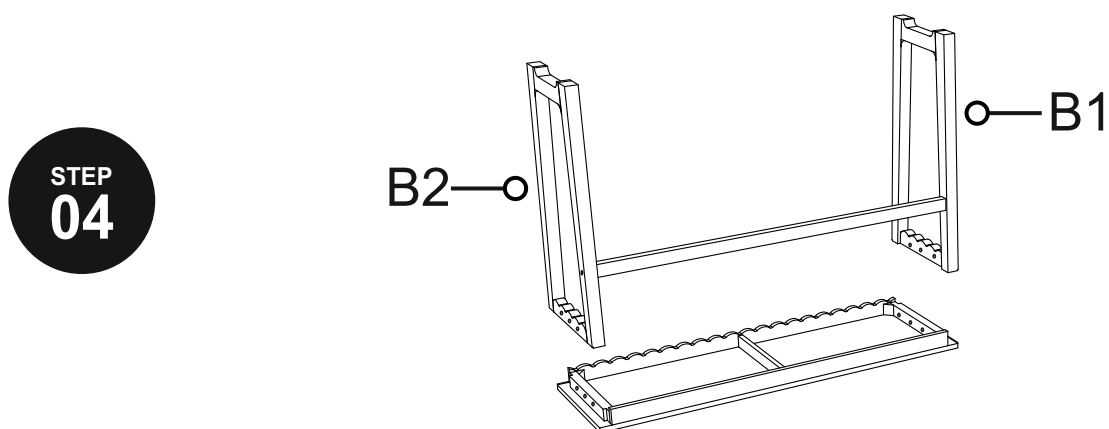

Place legs(B1&B2) frame in top frame (A) as show in the reference picture.

FOLLOW THE GIVEN STEP-BY-STEP PROCESS TO ASSEMBLE

STEP
05

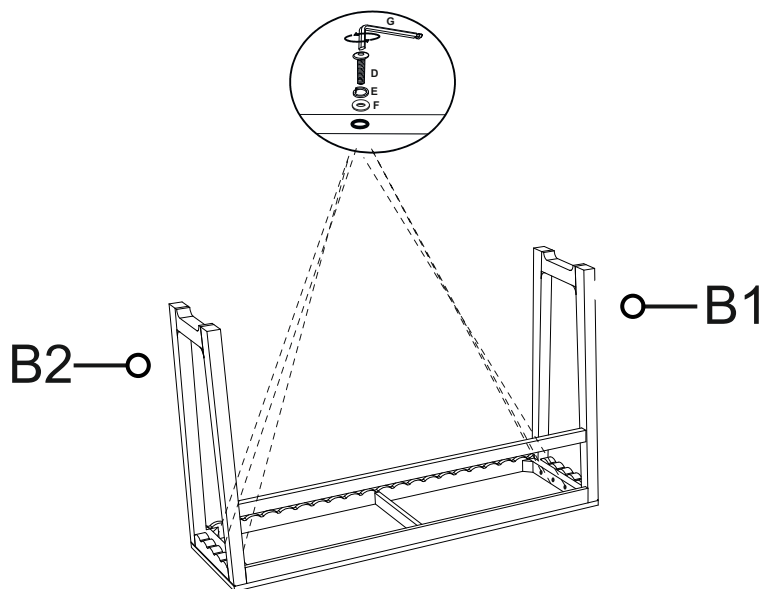

Using key (G) tighten bolt (D), lock washer (E) and flat washer (F) to tighten the top frame (A) and legs (B1&B2) as show in the reference picture.

STEP
06

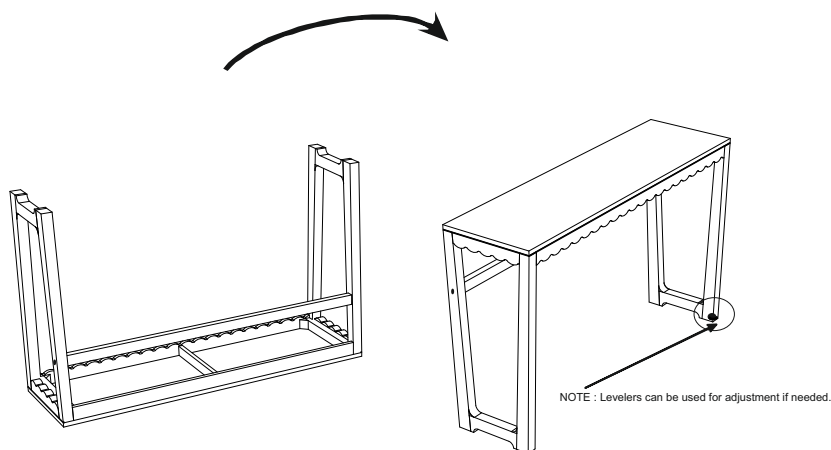

Flip the table right side up on the legs.
Adjustable levelers on the bottom of each leg can be used for additional leveling adjustments if needed. Assembly is now complete and the product is ready to use.

Anti-Tip Measures

! WARNING

Warning: Serious or fatal injuries can occur from furniture tip-over. To help prevent furniture tip-over.

- Use provided mounting hardware to secure furniture to the wall. This may reduce but not eliminate the risk of furniture tip-over.
- Do not allow children to climb on furniture.
- Keep remote controls, toys, and other items that might attract children off of his product.
- Unless specifically designed to accommodate, do not set televisions or other heavy objects on top of this products."

Furniture tip overs can result in death or serious injuries. To reduce the likelihood of tip over, this product should be used with the enclosed Anti-Tip Kit. This Anti-Tip Kit is only a deterrent. It is not a substitute for proper adult supervision. Manufacturer and retailer assume no liability for improper installation or excess loads placed on screws, brackets, or straps. When properly installed, this restraint provides protection against unexpected tipping of furniture. This Anti-Tip Kit **MUST** be installed into the wall using proper mounting hardware OR into a wall stud using appropriate screws. Position of the Anti-Tip Kit depends on the product and the location of the wall studs. The hardware provided is not a comprehensive solution for all wall types. Be sure to consult a professional or your local hardware store to determine the hardware needed for your specific wall type (plaster, drywall, concrete, etc.).

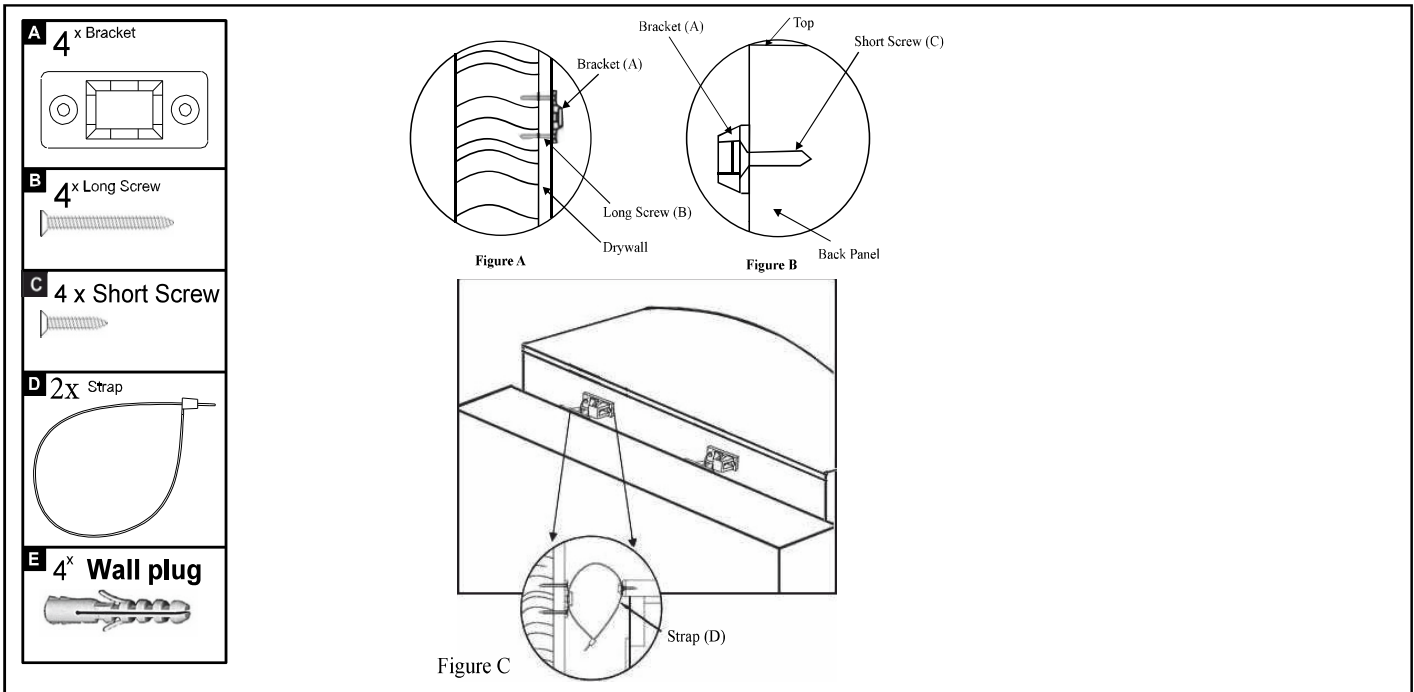

Using a second person to assist you, place the unit in the desired final location against a wall. It is suggested to use a stud finder to find wall studs along the length of the unit and roughly 1 inch below the top of the unit. Where possible, mark a drill hole position on the wall where there is a stud and use a drill or screwdriver (NOT INCLUDED) to attach wall Brackets (A) to the wall using Long Screws (B) in the location of the wall studs.

In a case where there is no wall stud, hold Brackets (A) on wall and mark the drill hole positions so that they are roughly 1 inch below the top of the piece. Using a drill with a drill bit roughly the diameter of the plastic Wall Plugs (E), drill pilot holes in marked positions. Insert the plastic Wall Plugs (E) into the holes until the tops are roughly flush with the wall. Align the holes and insert the Long Screws (B) through Brackets (A) and into the corresponding holes in the wall using a Phillips head screwdriver (NOT INCLUDED).

Next, attach remaining 2 Brackets (A) to the back of the piece using Short Screws (C) so they align with Brackets installed on the wall. Loop Straps (D) through Brackets (A) on the furniture piece, then through Brackets (A) on the wall and tighten until snug. Installation is now complete.

IMPORTANT: Check that the Wall Bracket is firmly screwed into the wall and the Cable Tie is snug.

If there is any hesitation, please consult a professional or your local hardware store.

ASSEMBLY INSTRUCTIONS