

# Assembly Instructions

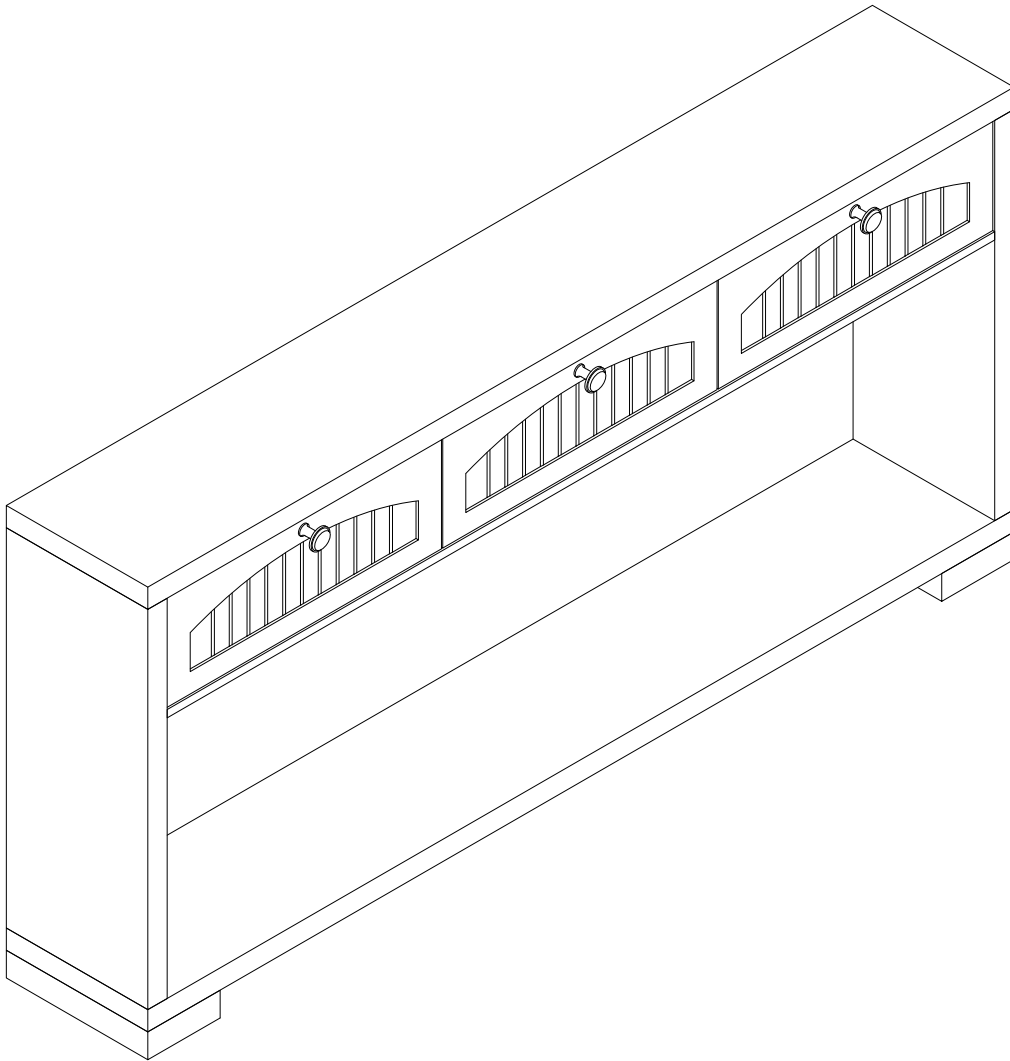

---

**Console Table**

Model No.  
**HOGA-F2318**

---

# Contact Us

## We're here to help you.

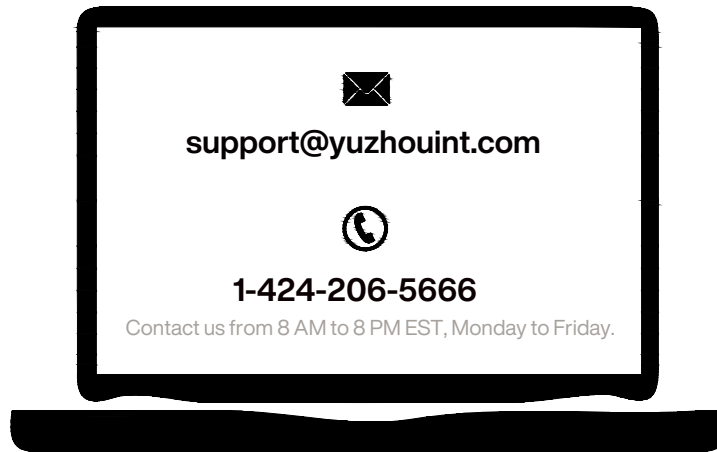

Your satisfaction is our top priority. If you encounter any issues with this product, such as missing or damaged parts, we're here to help. Please retain the original packaging and take photos of the packaging and the product, then contact us as soon as possible.

### Warm Tips

1. Carefully read these instructions and keep them for future reference.
2. Check the parts list and confirm everything's there before starting assembly.
3. When assembling, put all parts on a soft, smooth surface like a carpet to avoid scratches.
4. Don't fully tighten screws until all parts are confirmed in place to avoid misalignment.

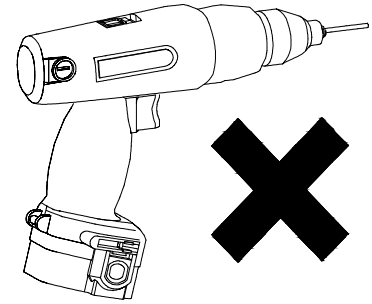
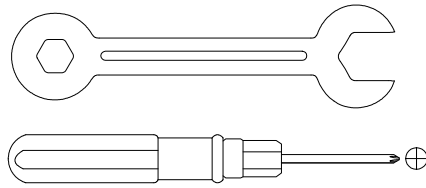
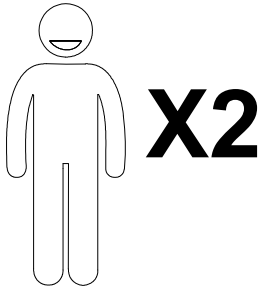

We recommend using hand tools for assembly.

If an electric screwdriver is used, reduce power and torque to avoid damage to the product.

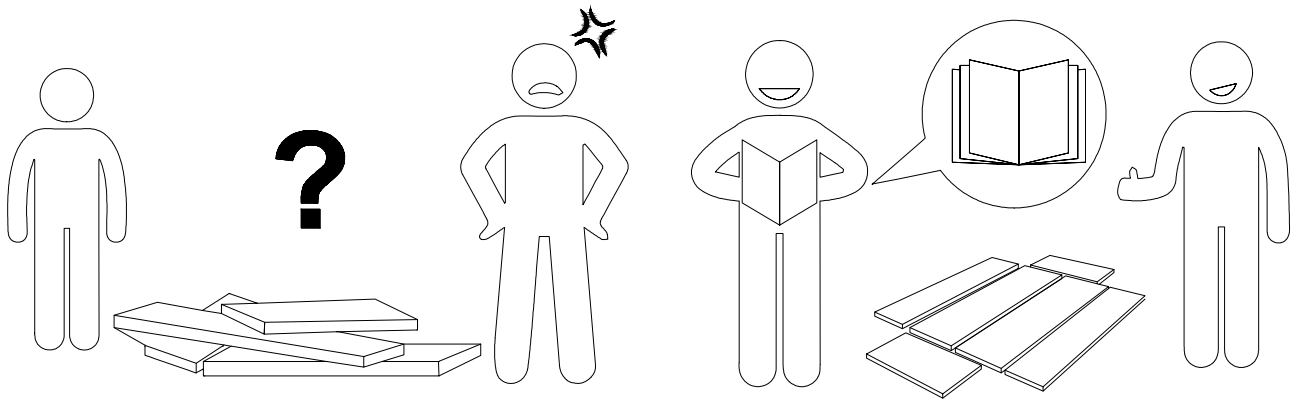

## Install the Anti-Tip Straps

Using the anti-tip straps can reduce the risk of tipping over, but can not eliminate it.

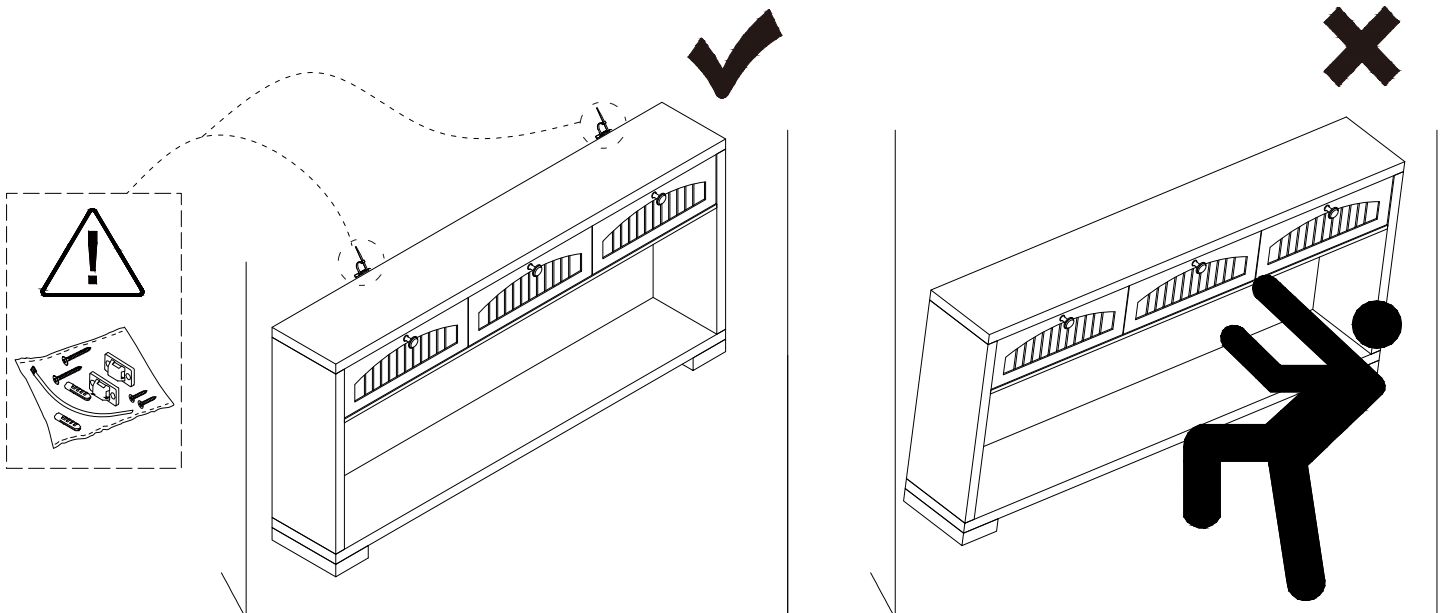

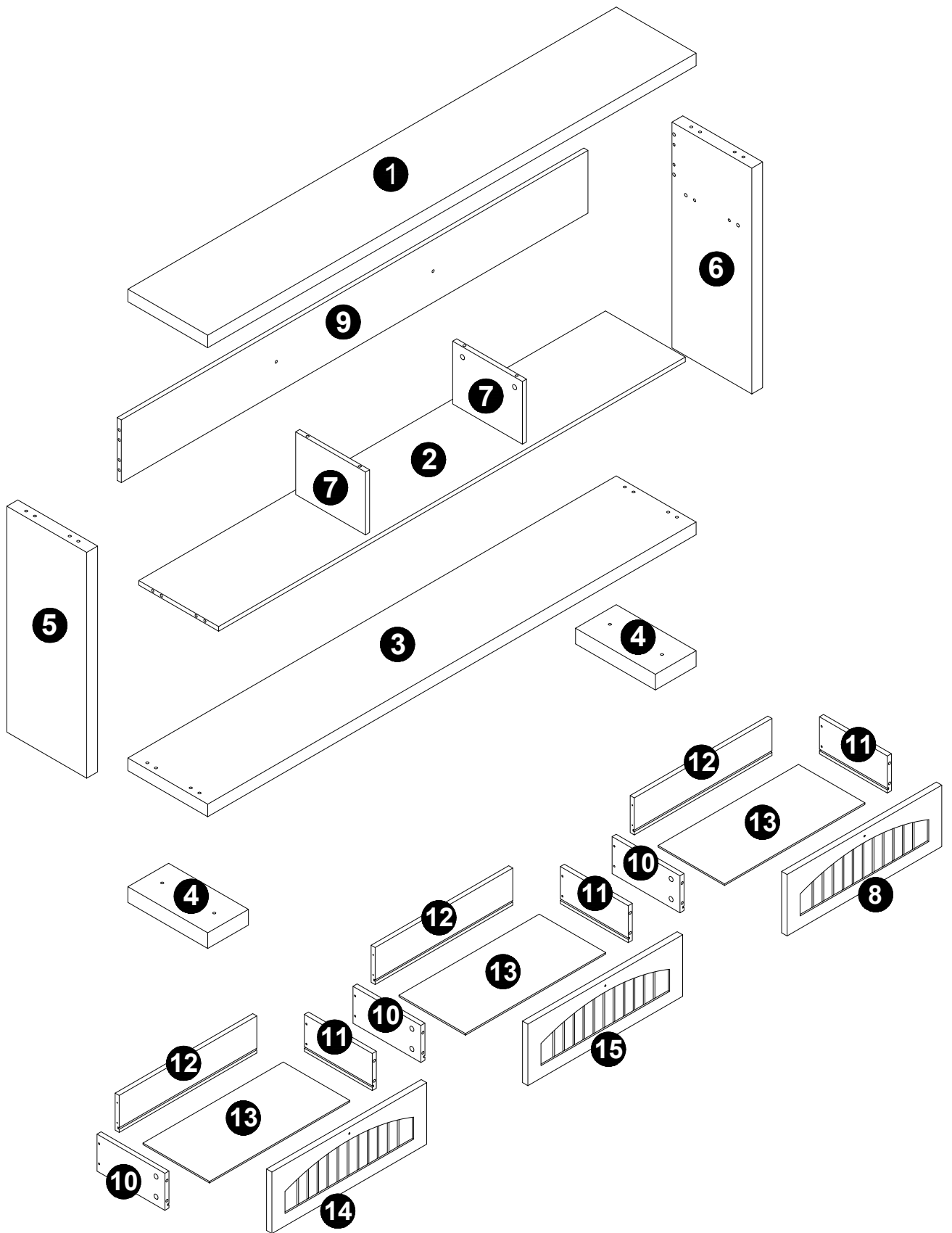

**⚠ Caution**

Make sure all parts are included. Most board parts are labeled or stamped on the raw edge. Contact us for a free replacement if you encounter any damaged or missing parts.



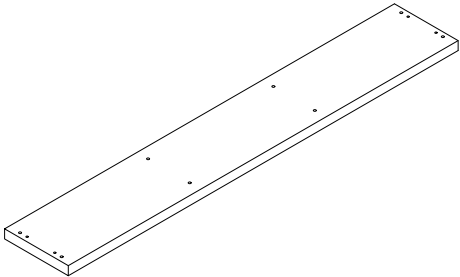
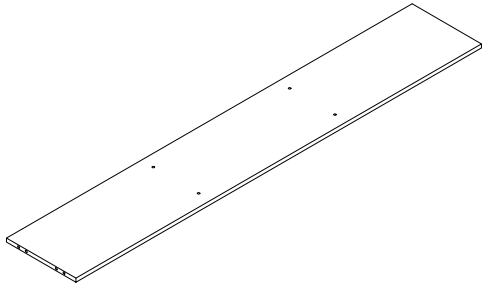
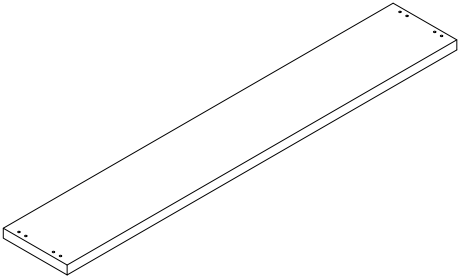
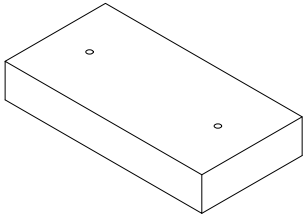
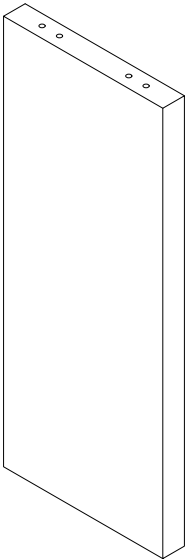
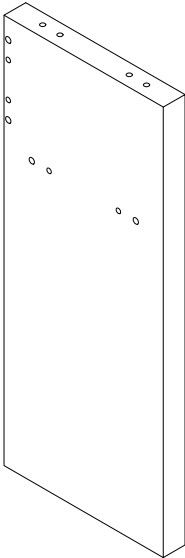
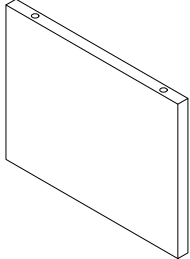
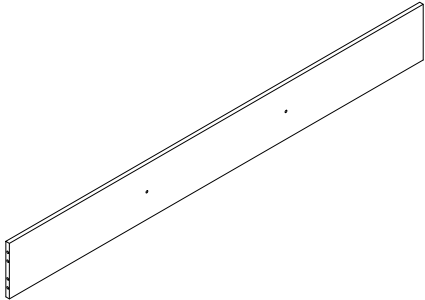
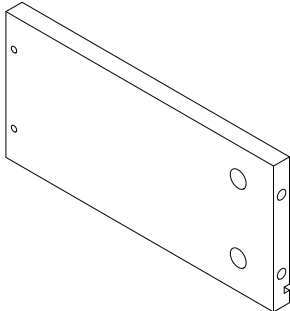



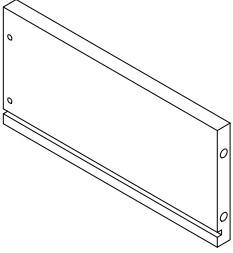
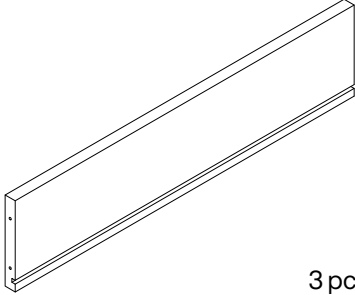
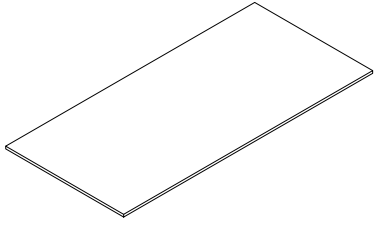
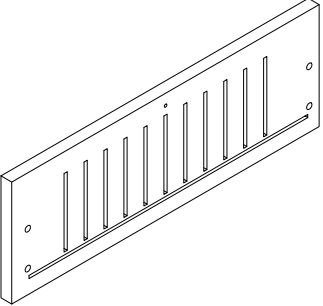
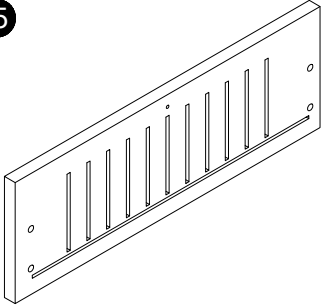

# Parts List

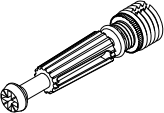
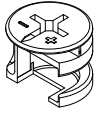
<p><b>1</b></p>  <p>1pc</p>	<p><b>2</b></p>  <p>1pc</p>	
<p><b>3</b></p>  <p>1pc</p>	<p><b>4</b></p>  <p>2 pcs</p>	
<p><b>5</b></p>  <p>1pc</p>	<p><b>6</b></p>  <p>1pc</p>	<p><b>7</b></p>  <p>2pc</p>
<p><b>9</b></p>  <p>1pc</p>	<p><b>10</b></p>  <p>3 pcs</p>	

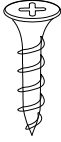
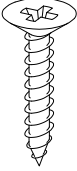
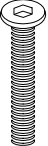
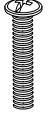
# Parts List

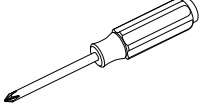
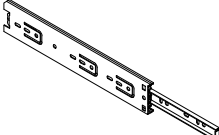
 <p>11</p> <p>3 pcs</p>	 <p>12</p> <p>3 pcs</p>	 <p>13</p> <p>3 pcs</p>
 <p>14</p> <p>1 pc</p>	 <p>15</p> <p>1 pc</p>	

# Hardware List

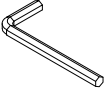
A	B	C	D	E	F
					
Ø6x40mm	Ø15x12mm	Ø7x38mm	Ø7x48mm	Ø3.5x14mm	Ø3.5x30mm
32+1 pcs	32+1 pcs	12+1 pcs	4+1 pcs	24+6 pcs	12+1 pcs
G	H	I	J	K	L
					
Ø6x60mm	Ø4x25mm	Ø8x30mm		250mm	
4+1 pcs	3+1 pcs	18+1 pcs	1 pc	3 sets	3 pcs
M	N	O			
					
25x25mm					
8 pcs	2 pcs	1 pc			

## Installation of Cams and Pins

Step 1-2: Align the plastic part with the mounting hole and press it in. If you can't press it in, loosen the screw counter clockwise or completely remove the screw from the plastic part and try again.  
Step 3-4: After pressing the plastic part into place, use a screwdriver to tighten the screw clockwise.

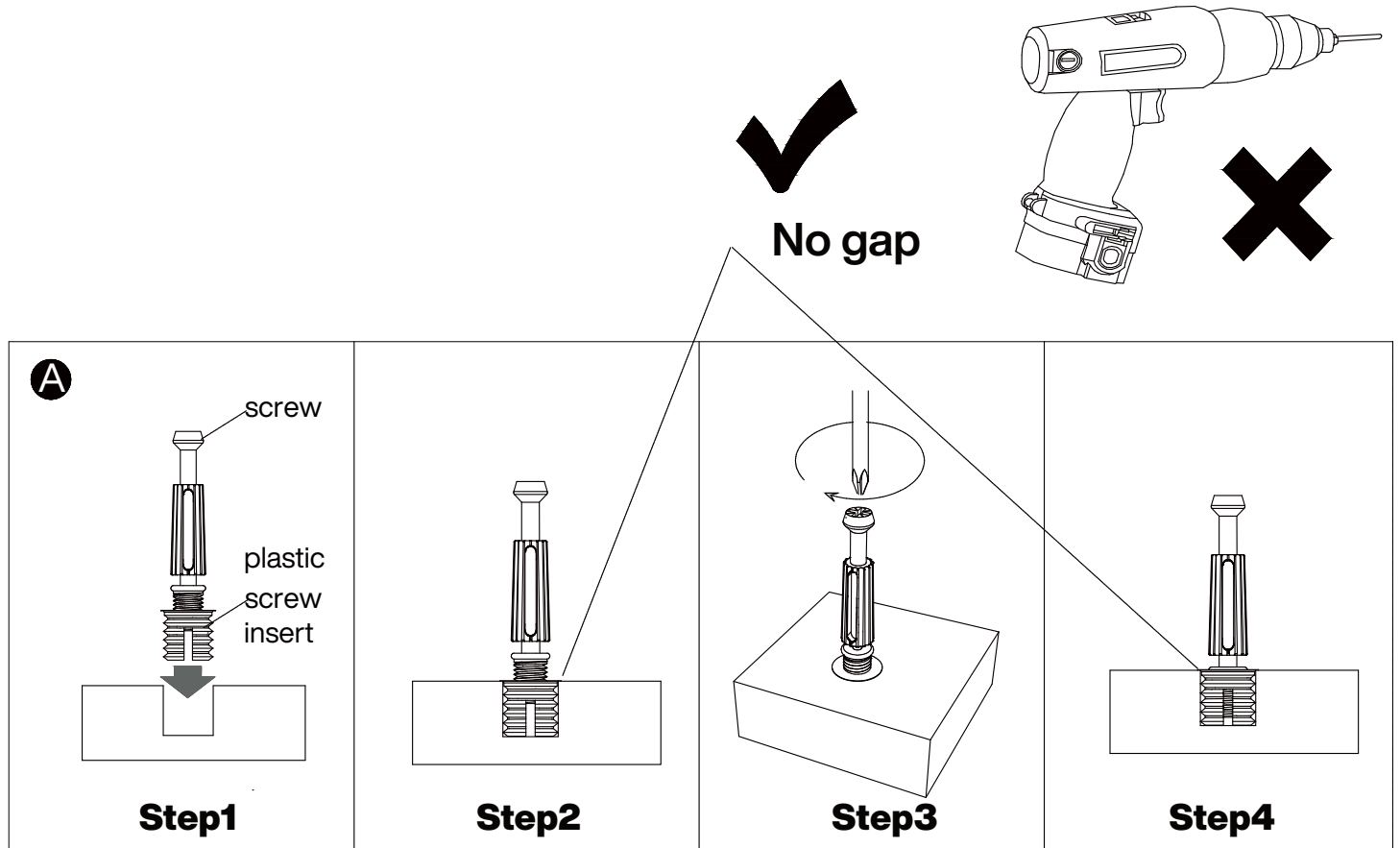

Screw the pin into the hole. Set the cams correctly by aligning the head of the cams with the lock pins. Lock the cam by turning the cam head with a screwdriver until it is tightened. Please do not use an electric screwdriver to assemble the unit.

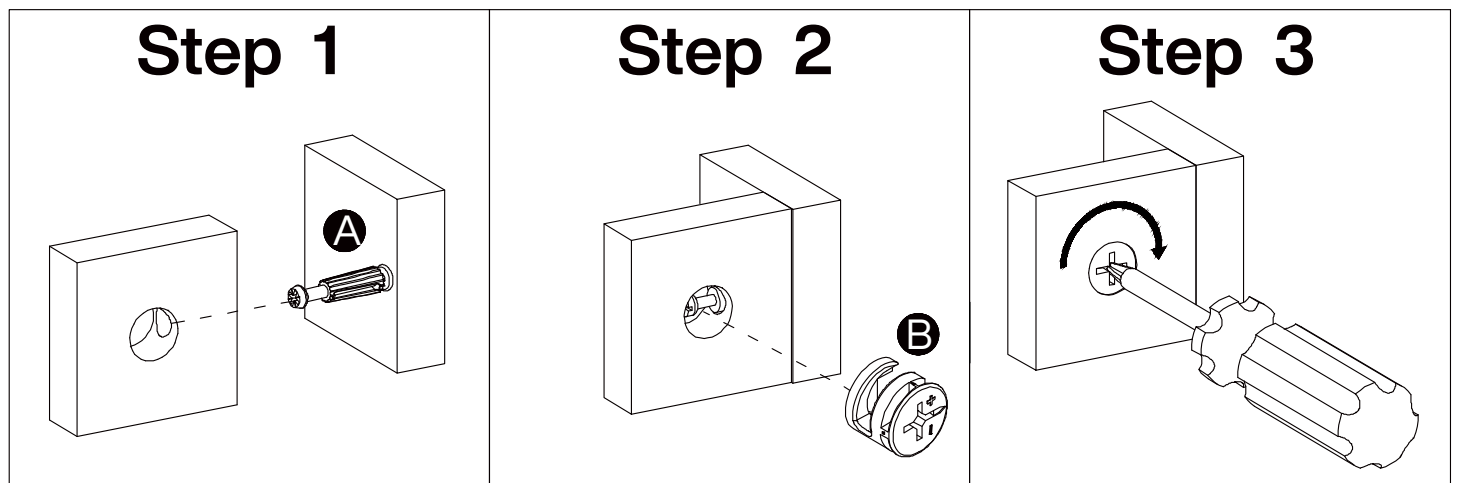

Please split component “K” into “K-1” and “K-2” before assembling the slide and then proceed to the next step of assembly

### Step 1

Pull apart component "K" to each side, and then gently push up the lever of component "K-2"

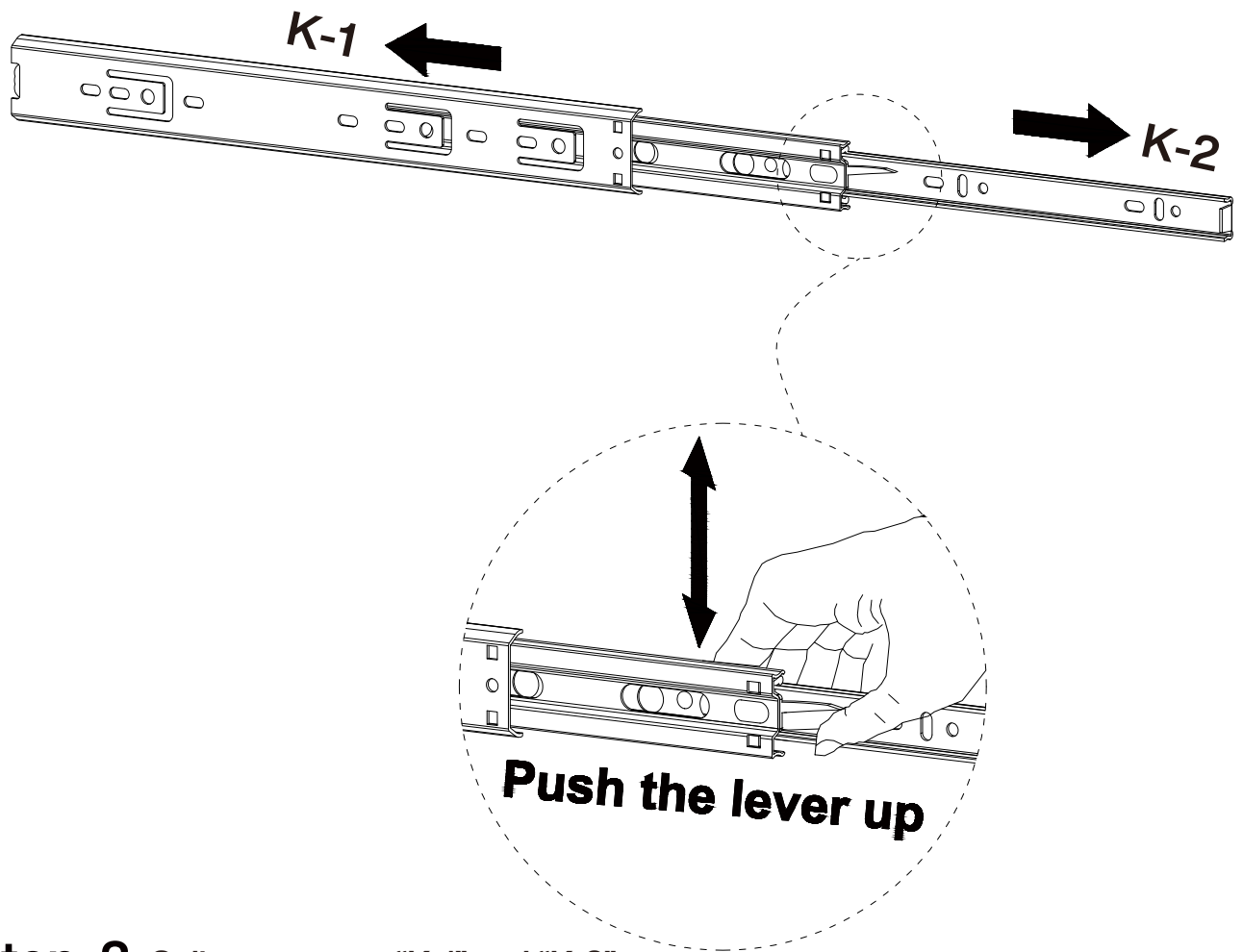

### Step 2 Split component “K-1” and “K-2”

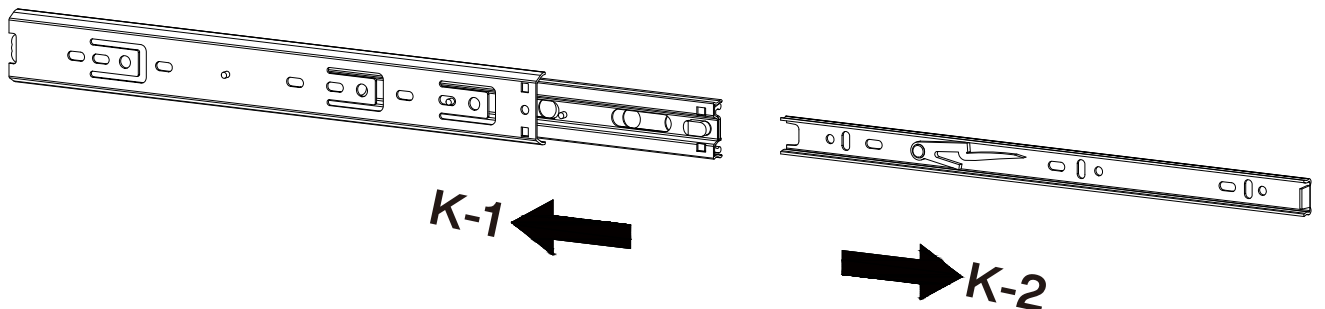

1

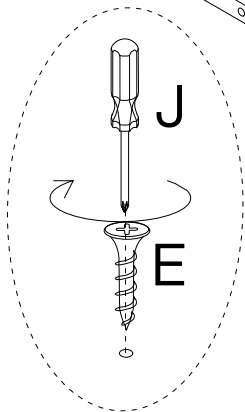
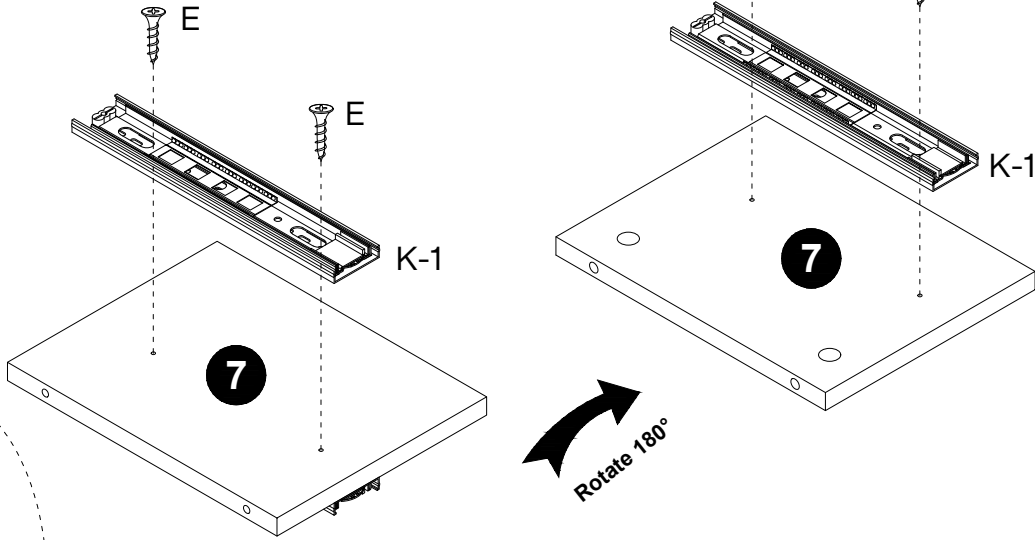
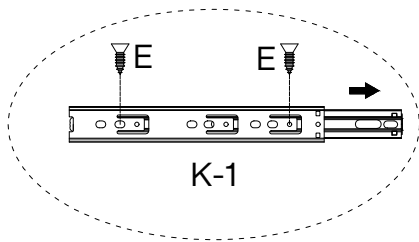

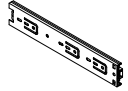
E

Ø3.5×14mm
8 pcs
K-1

250mm
4 pcs

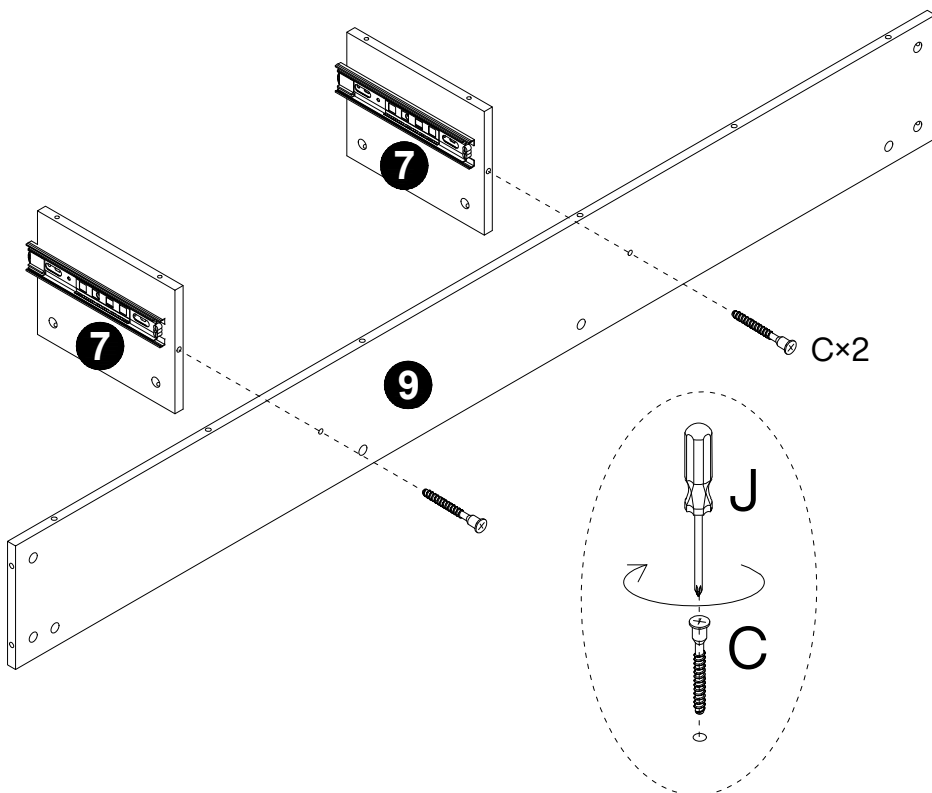
X2

2





C

Ø7×38mm
2 pcs
J

1 pc

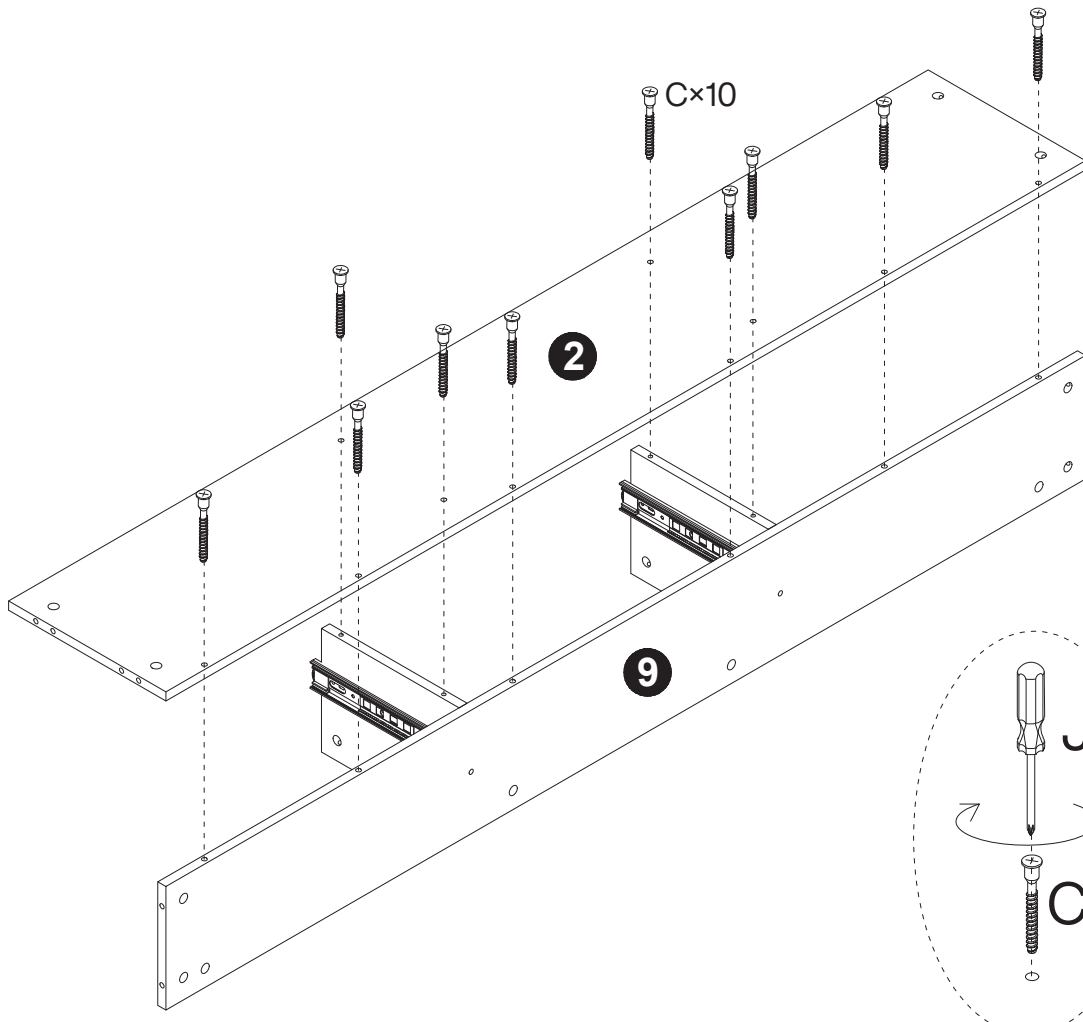

**3**

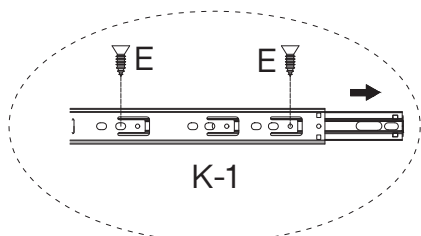
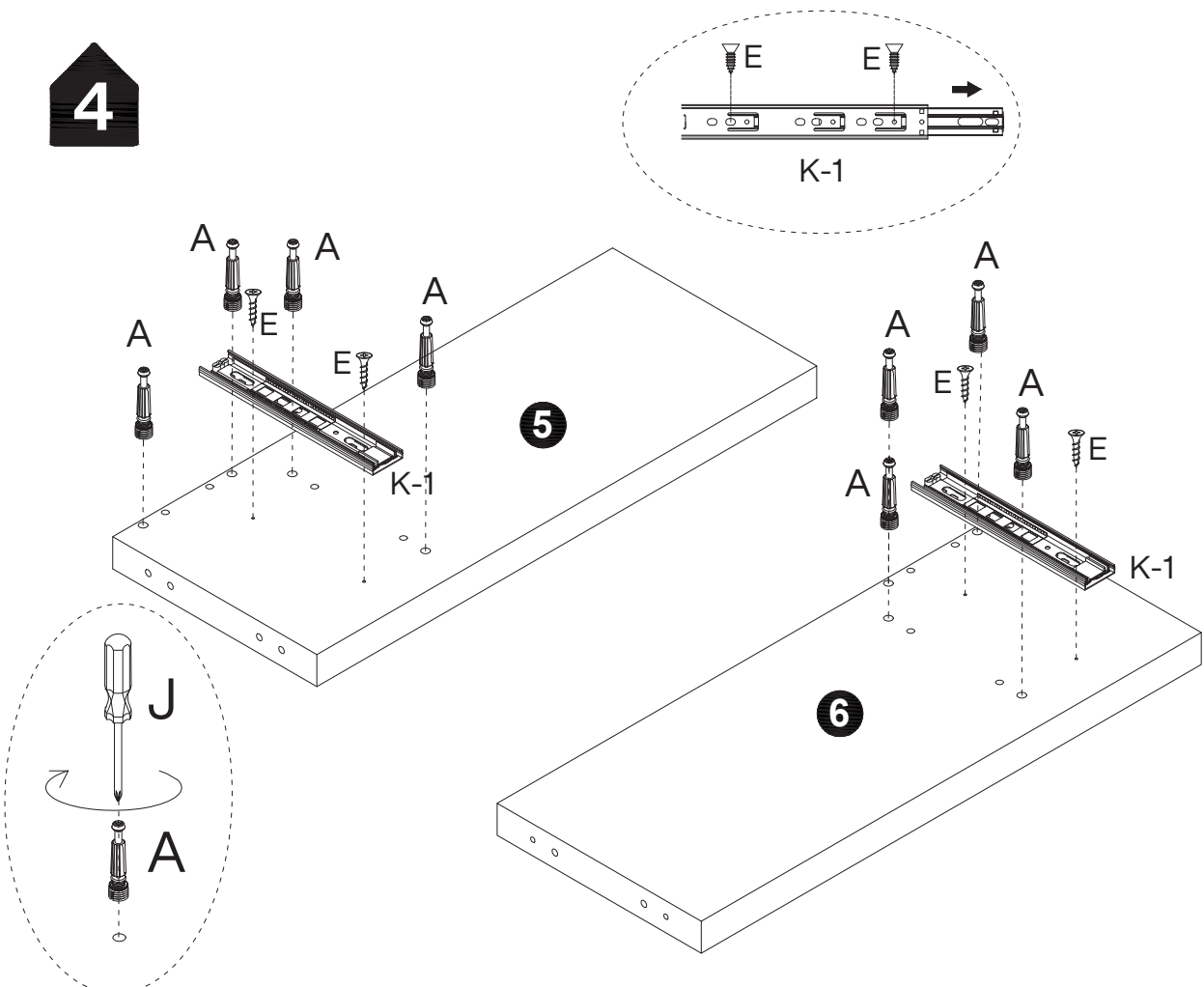

C

Ø7×38mm
10 pcs

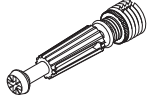
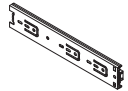
**4**

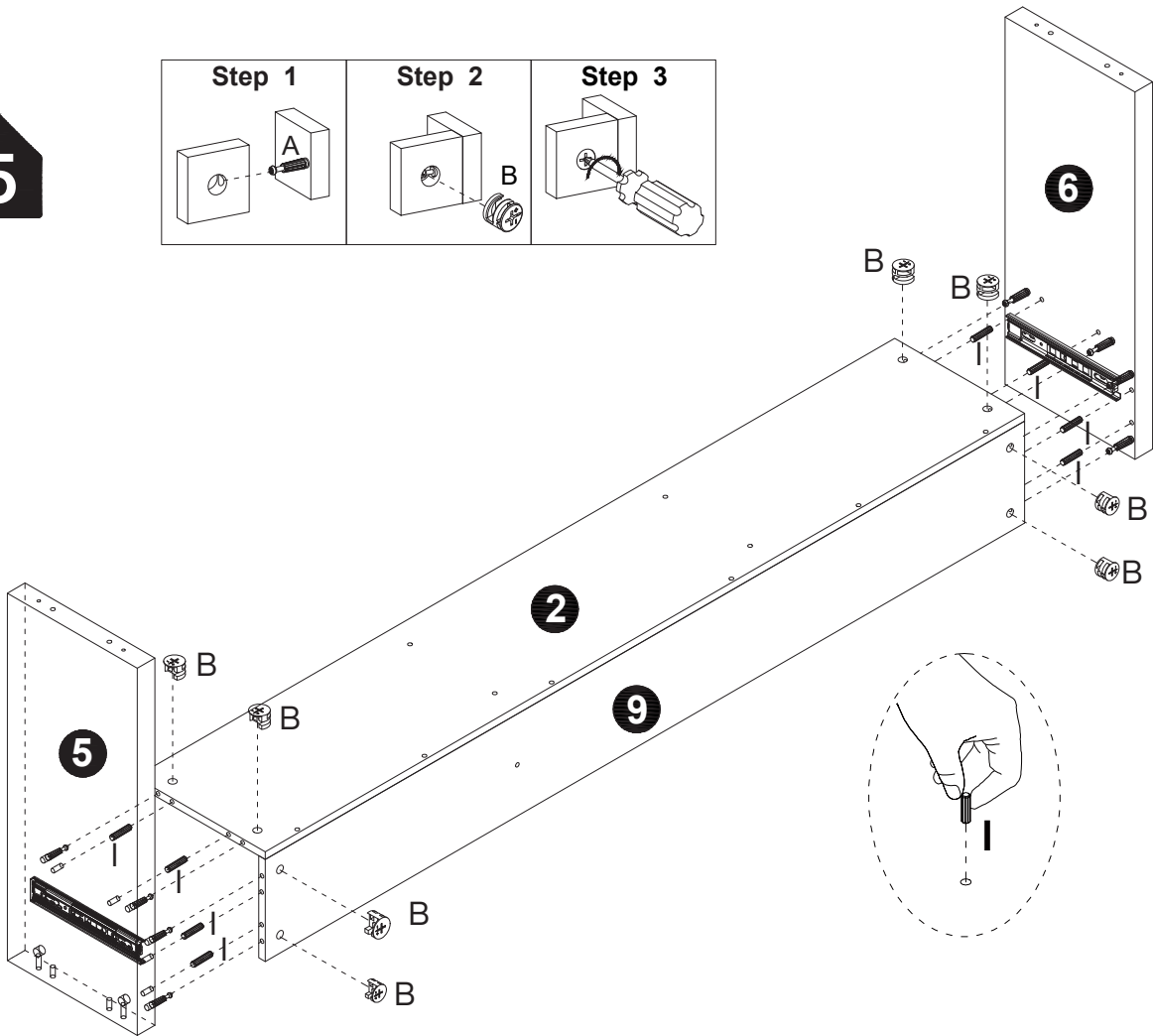
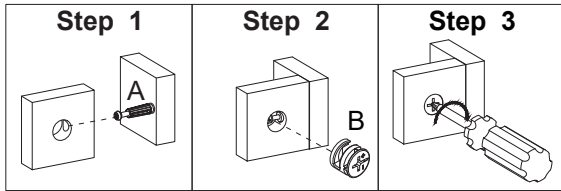

A

M6×40mm
8 pcs
K-1

250mm
2 pcs
E

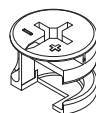
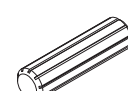
Ø3.5×14mm
4 pcs

5

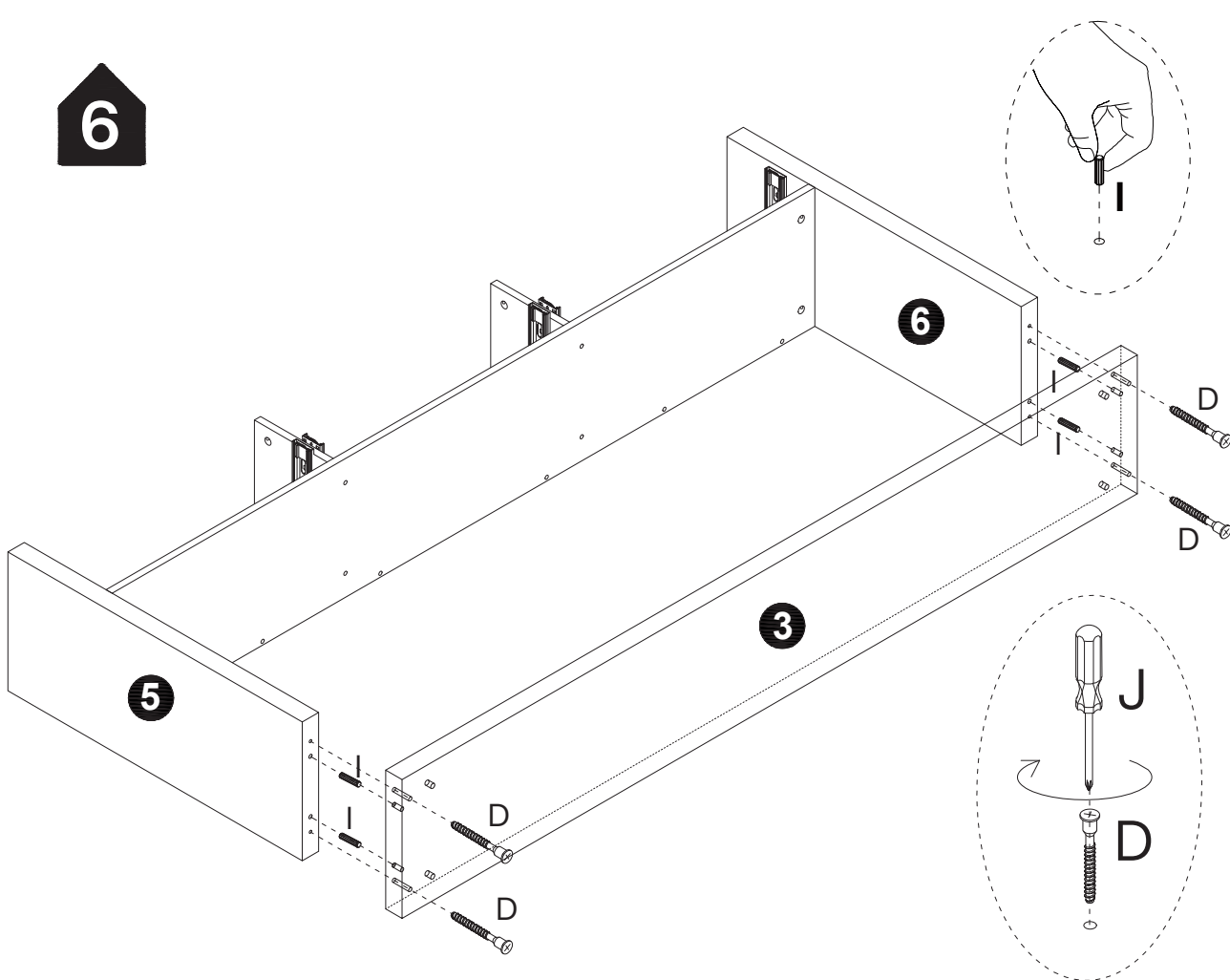

B

Ø15×12mm
8 pcs
I

Ø8×30mm
8 pcs

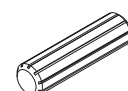
6

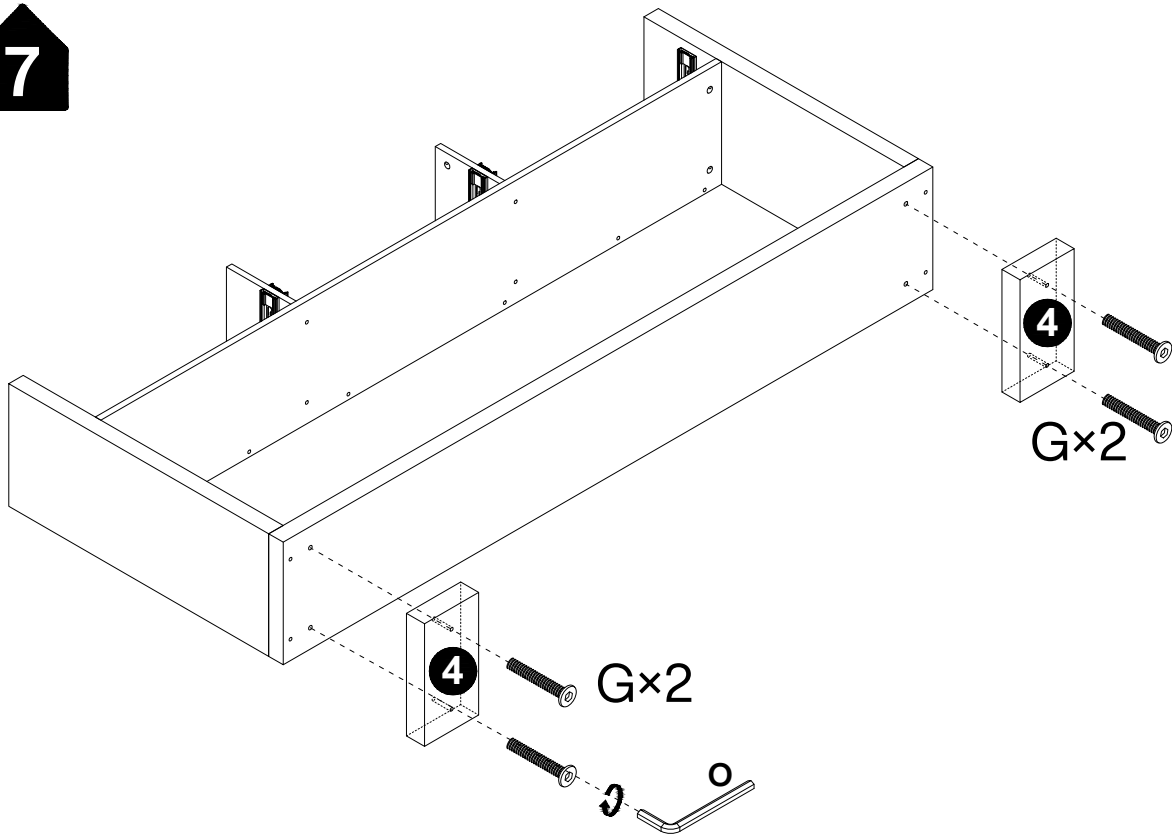

D

Ø7×48mm
4 pcs
I

Ø8×30mm
4 pcs

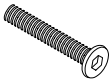
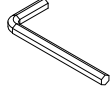
7

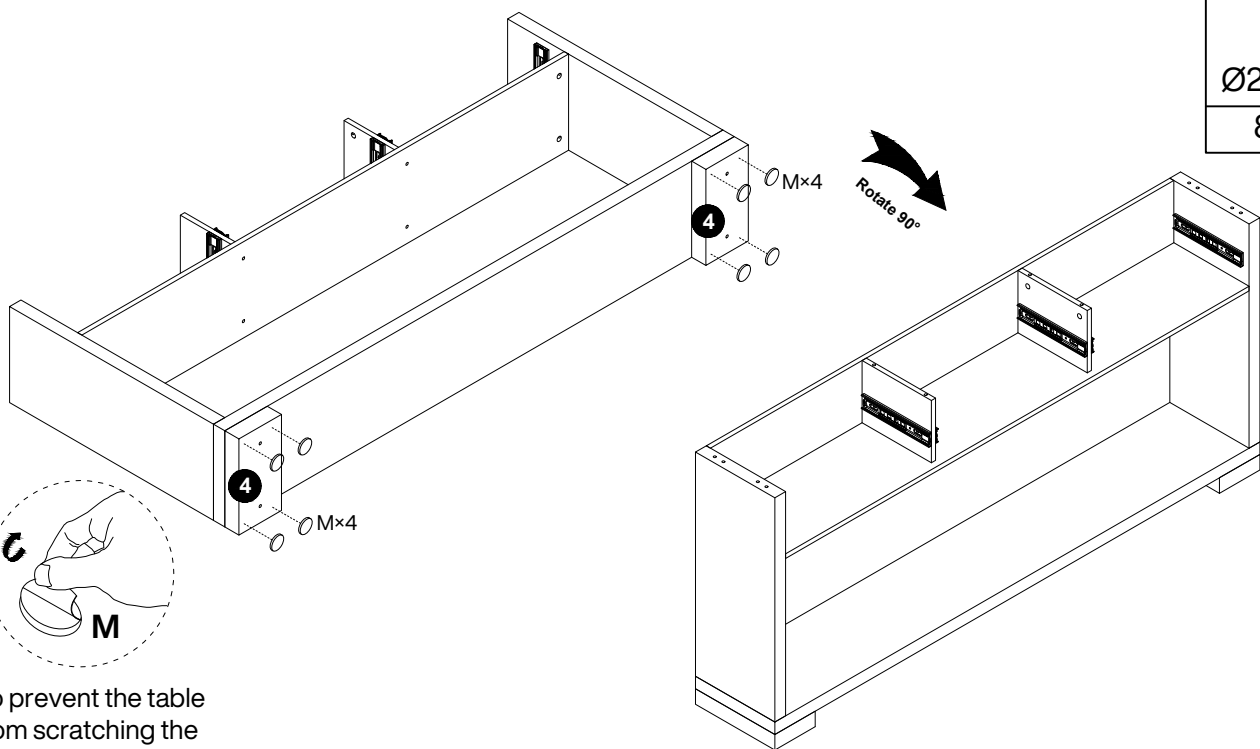

G

Ø6×60mm
4 pcs
O

1 pc

8





M

Ø25×2mm
8 pcs

To prevent the table from scratching the floor, please peel off the tape on the #M and tape them to the corners of the table before use.

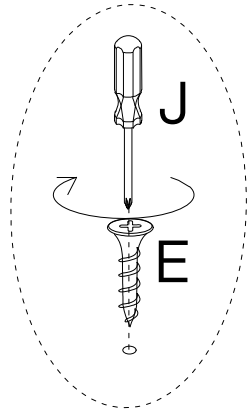
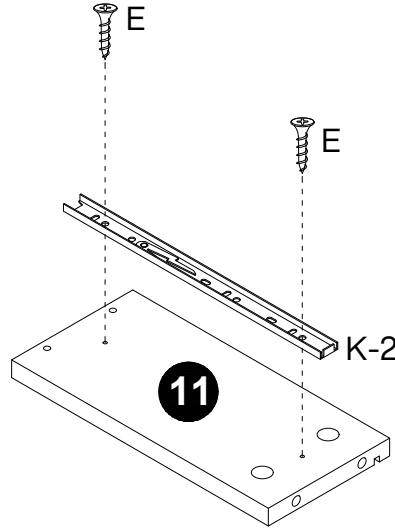
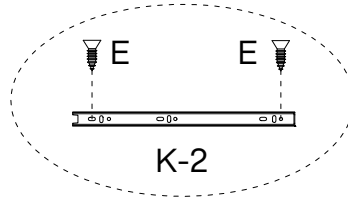
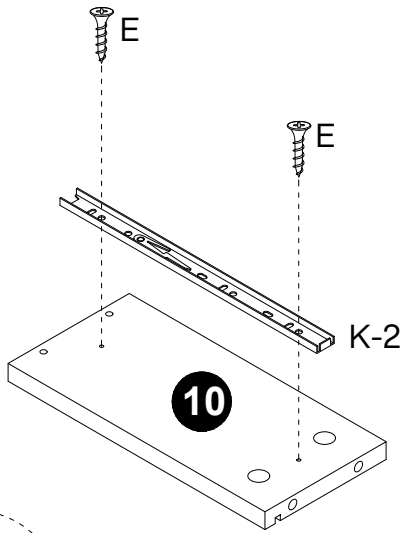

11



E

Ø3.5×14mm
12 pcs
K-2

250mm
6 pcs

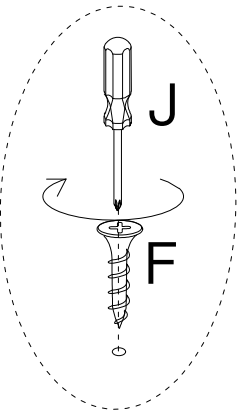
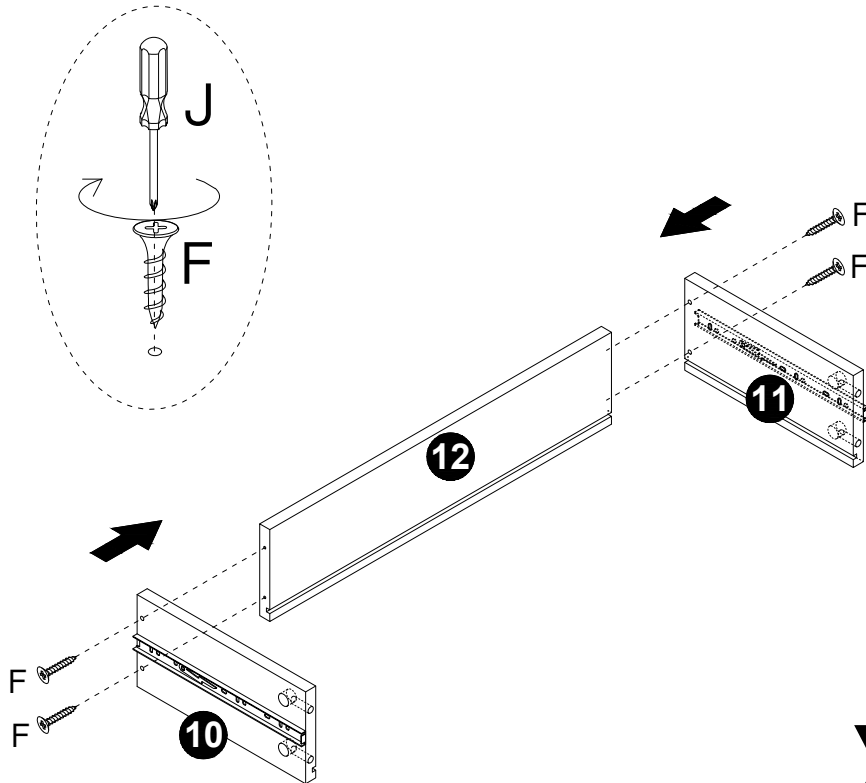
X3

12



F

Ø3.5×14mm
12 pcs

X3

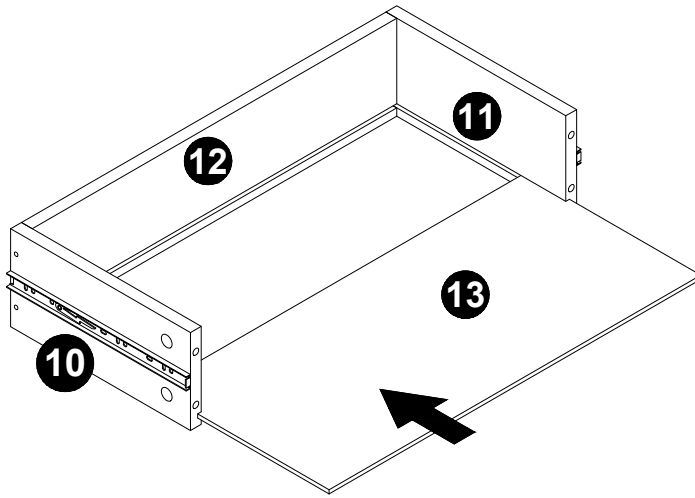
13



X3

14

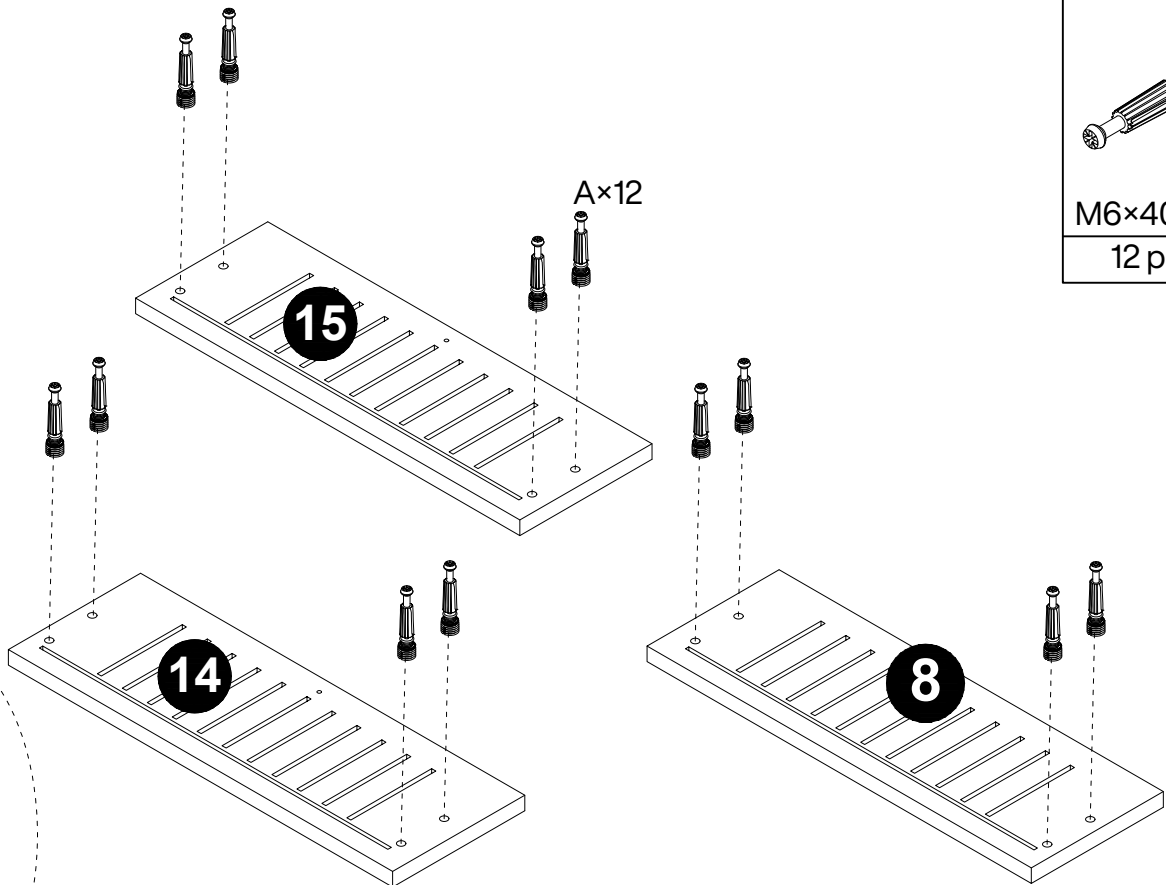

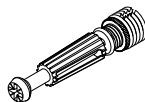
A

M6x40mm
12 pcs

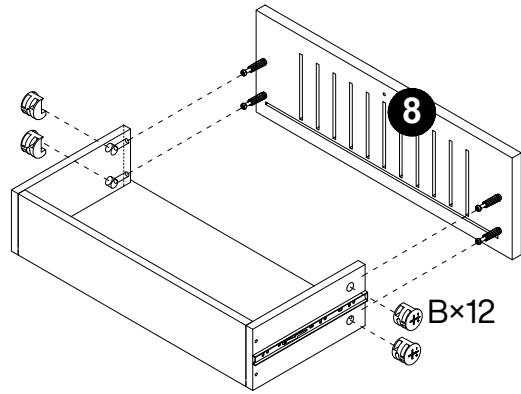
15

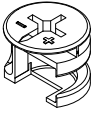

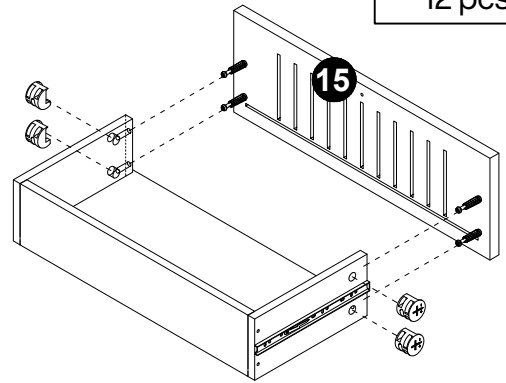
B

Ø15×12mm
12 pcs

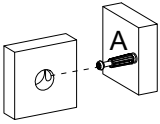

**Step 1**

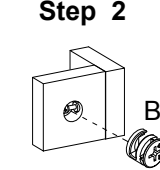

**Step 2**

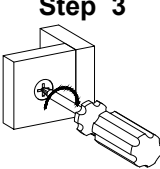
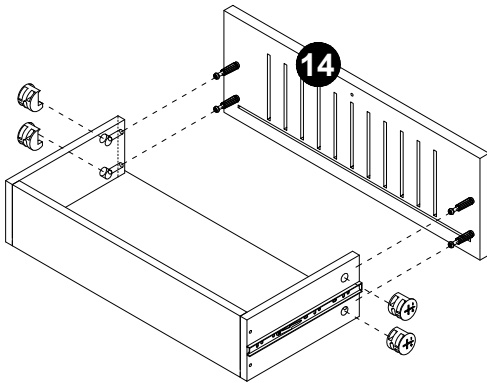

**Step 3**

16

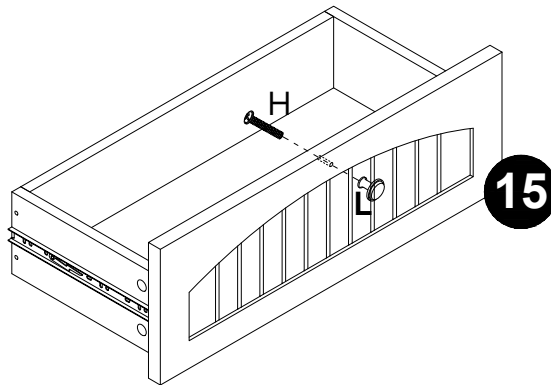
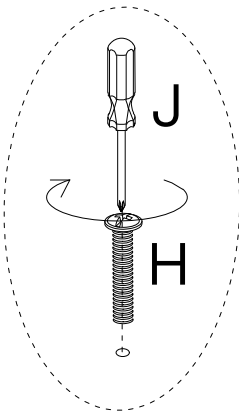

L

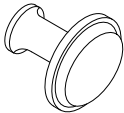
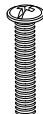
3 pcs
H

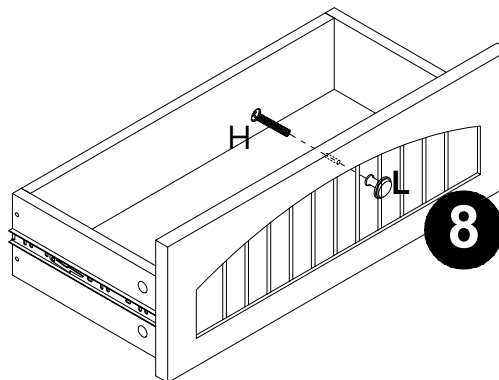
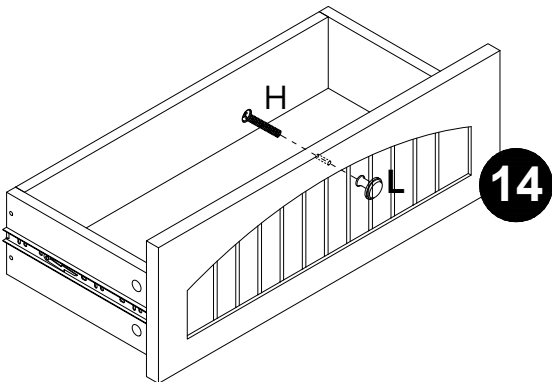
Ø4×25mm
3 pcs

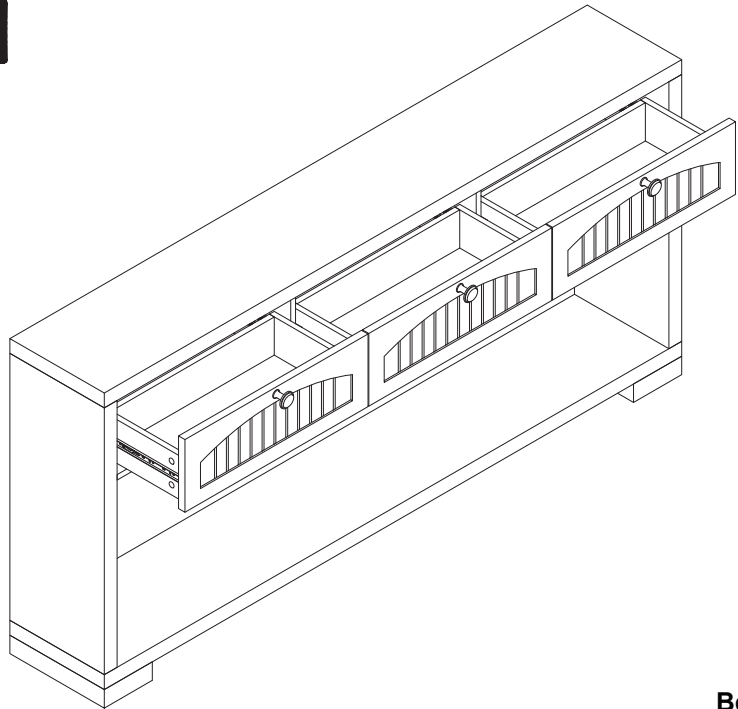

17

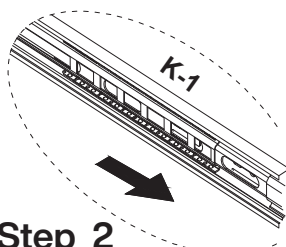

Step 1



Step 2

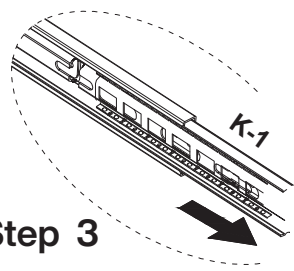

Step 3

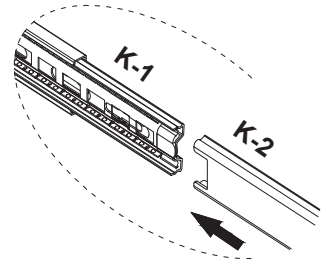

Before installation, slide the inner iron pieces of #K-1 to the outermost side. Then align it with #K-2 and gently push it inward to complete the slide installation.

18

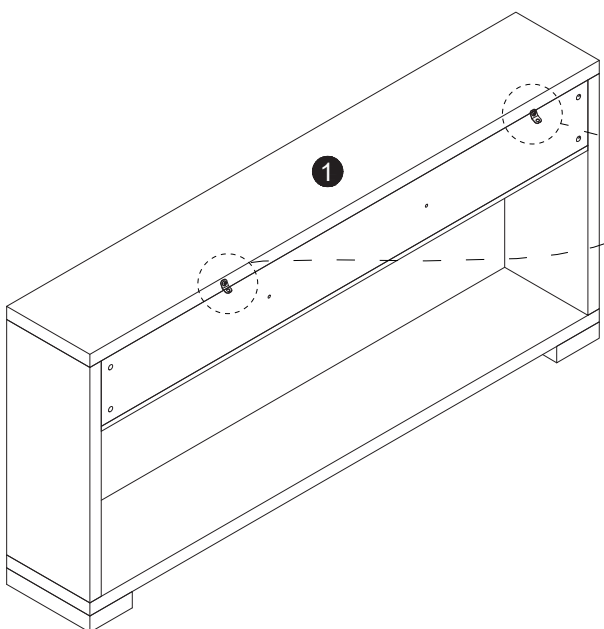

Step1

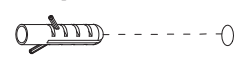

Step2

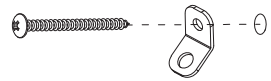

Step3

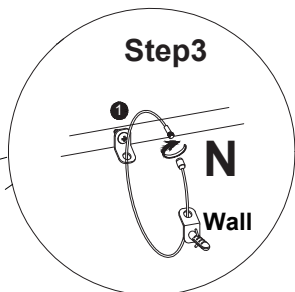

N
2 pcs

**Thank you for your support!**

