

To deodorize the leather
leave the chair in a shady
outside for 1-2 days.

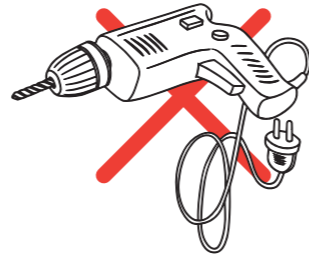

For longer use

Re-tighten bolts every 6 months by using
the enclosed allen-key.
*Using an electric drill can damage the chair.
Please re-tighten bolts manually.



INSTRUCTION MANUAL



Safety Information



Sit in the center of the
chair, with your back to
the backrest



Do not sit at the front
edge of the chair



Do not stand on the
chair



Do not use the chair
with more than one
person



Do not push the chair
around when a person
is sitting in it



Do not push down on
the backrest when a
person is reclined



Do not place all your
weight on only the
backrest

Package List



(A)*1 Backrest



(B)*1 Seat



(C)*1L * 1R Armrests

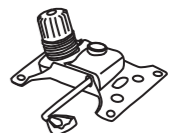

(D)*1 Mechanism

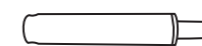

(E)*1 Gas Lift

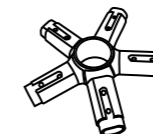

(F)*1 Base



(G)*5 Legs



(H)*5 Casters



(I)*4 Bolts



(J)*6 Bolts



(K)*10 Bolts



(L)*4 Bolts

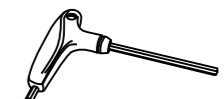

(M)*1 Wrench

INSTRUCTION MANUAL

Assembly Instruction

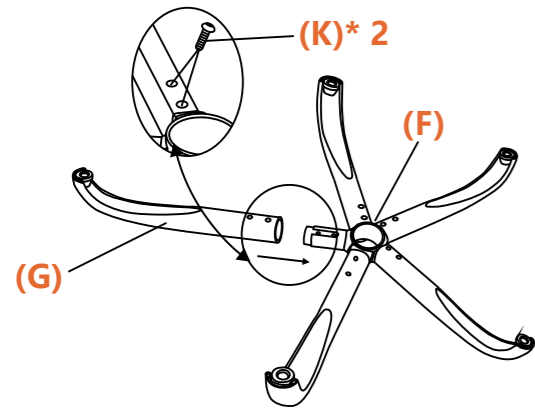

1 Turn the Base (F) upside down, insert the Legs (G)*5 into the Base one by one. Use Wrench (M), secure both with Bolts (K)*10.

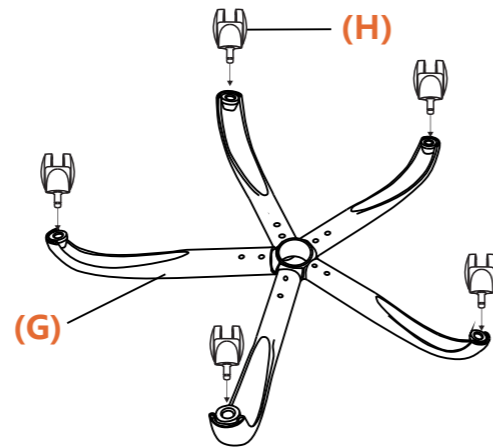

2 Press Casters (H)*5 into the holes at the end of Legs (G)*5.

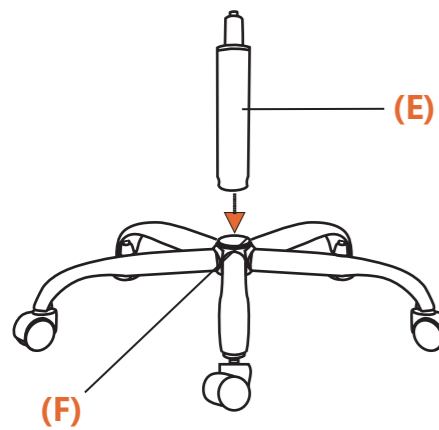

3 Insert the Gas Lift (E) into the Base (F).

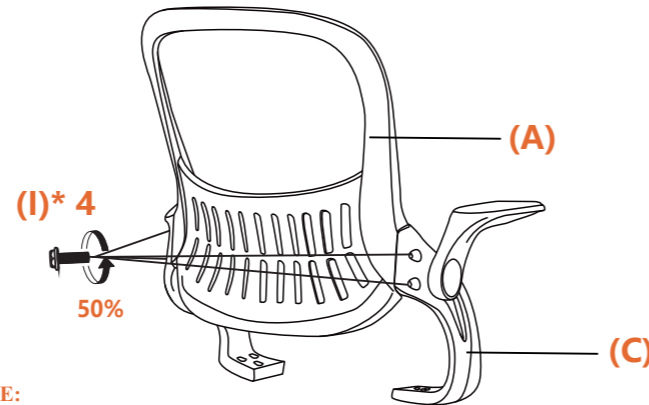

NOTE:

1. Bolts (I) are only tightened 50%.
2. Armrests (C)x1Lx1R are marked with "L" (Left) and "R" (Right) to show which side they should be installed.

4 Using Wrench (M), install Armrests (C)x1Lx1R to both sides of the Backrest (A) with Bolts (I)*4.

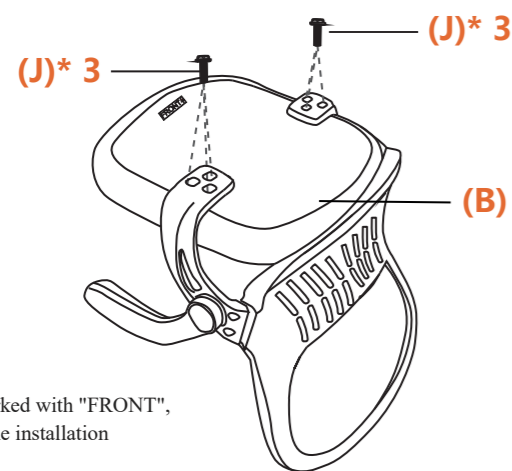

NOTE:

The Seat (B) is marked with "FRONT", please make sure the installation direction is correct.

5 Turn the Seat (B) upside down. Using Wrench (M), install Armrests (C)x1Lx1R to the Seat with Bolts (J)*6.

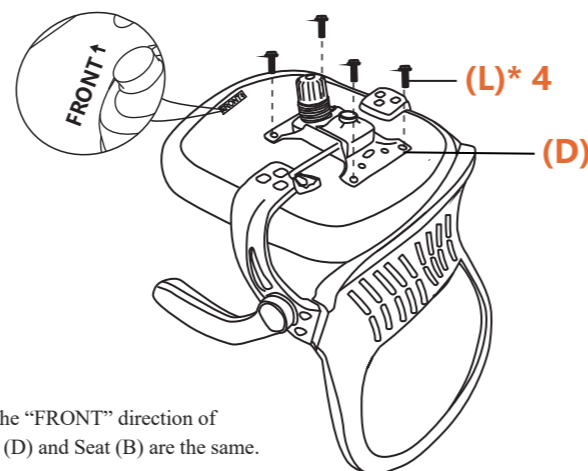

NOTE:

Make sure the "FRONT" direction of Mechanism (D) and Seat (B) are the same.

6 Using Wrench (M), attach Mechanism (D) to the Seat (B) with Bolts (L)*4.

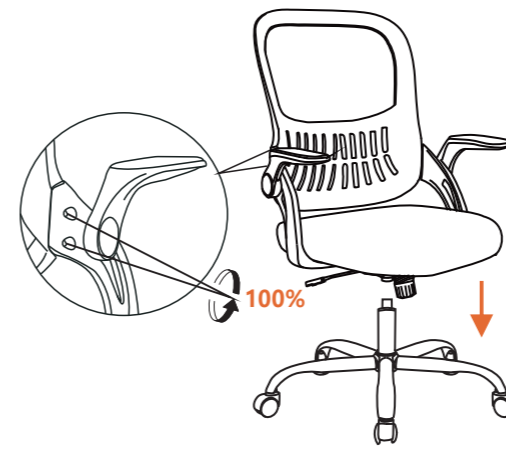

7 Using Wrench (M), 100% tighten the previously installed Bolts (I)*4 on the Armrests (C)x1Lx1R. Align the hole on Mechanism (D) with Gas Lift (E), and press the Chair down until it is fully secured.



8 Finish the installation.

Instructions For Use

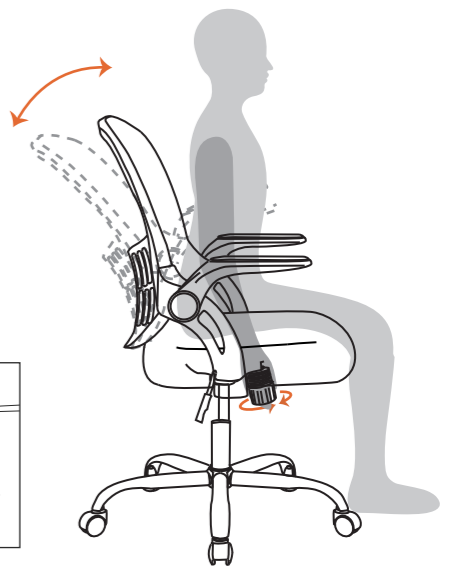
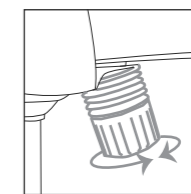
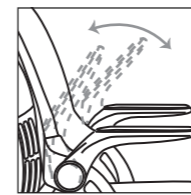

CAUTION:

- * Before using the chair, check to ensure that all bolts are fully tightened.
- * Lubricate all parts and tighten all bolts every 6 months or whenever needed.