

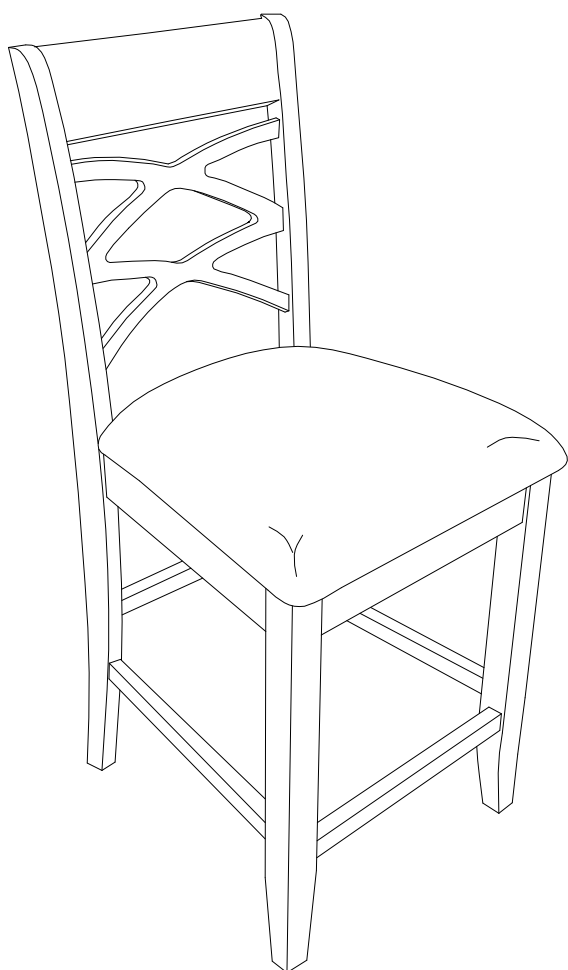









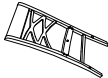

Assembly Instructions

Double Cross Back 24" Counter Height Stool

A packet with complete set of hardware can be found by pulling the red ribbon that's easily visible upon opening the box.



LIST OF PARTS

A	Chair Back	1	
B	Seat Pad	1	
C	Side Stretchers (L&R)	2	
D	Front Stretcher	1	
E	Front Legs	2	
F	Bolt 1/4"*2"	1	
G	Bolts 1/4"*2-1/2"	4	
H	Bolts 1/4"*3"	4	
I	Lock Washers	9	
J	Flat Washers	9	
K	Screws 8*1-3/4"	6	
L	Allen Wrench	1	

Step 1

Fasten the seat pad onto chair back with one shortest bolt (F & I & J) in the center, and four long bolts (H & I & J) on two sides. Do not tighten.

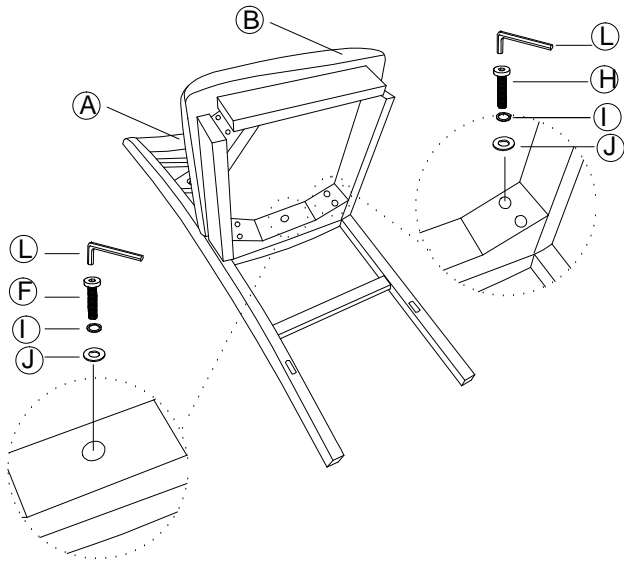

Step 2

Place the chair assembly upside down on a table. Insert two side stretchers into back leg holes. Make sure the ends with "L" and "R" stickers on the bottom of stretcher should be connected to back legs. Also, make sure the front leg sticker matches the sticker on the seat frame before attaching two front legs. Fasten bolts when all stretchers in place and do not tighten bolts.

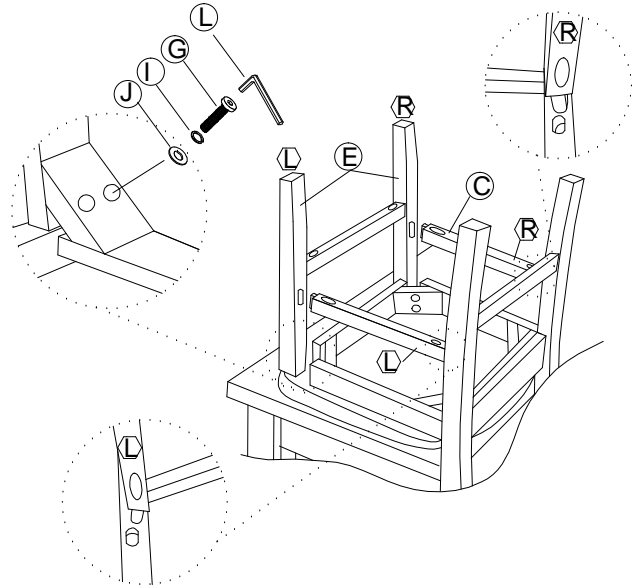

Step 3

Place the chair right side up on an even surface. Now tighten all bolts when all legs are properly leveled.

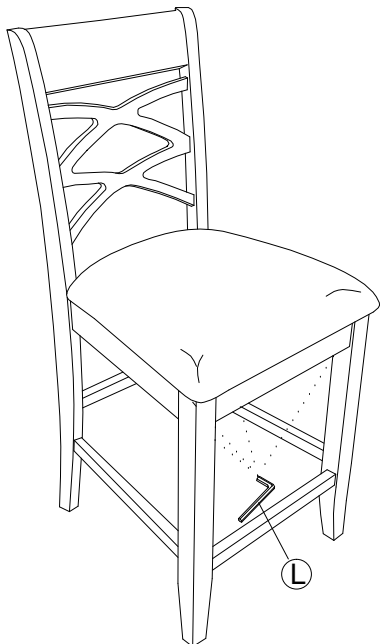

Step 4

Fasten the stretchers and legs with screws.

