

# ASSEMBLY INSTRUCTIONS

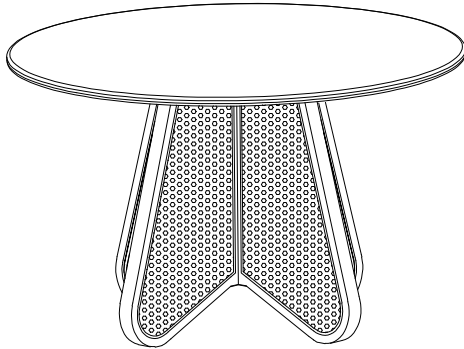

**+ Do Not Use Power Tools**



**+ Suggested Adults**



## + Parts Included

① Center post (1 pc)

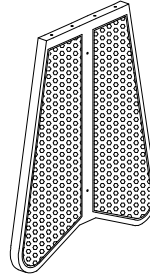

② Side post (2 pcs)

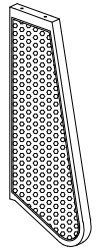

③ Connective panel (1 pc)

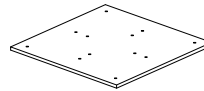

④ Top panel (1 pc)



## NOTE:

- 1 Read instructions cover to cover.
- 2 Save all packaging until assembly is completed.

## 1 IMPORTANT SAFETY INFORMATION

- Do not** assemble the product if the parts arrived damaged.
- Do not** assemble if Hardware parts are missing.

## 2 IMPORTANT ASSEMBLY INFORMATION

Assembly Step If loosening persists, please make sure to tighten all the bolts periodically, or use a thread locker adhesive.

## + Parts Included

A. Bolt  
Ø8x25mm (5 pcs)

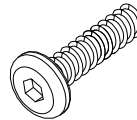

B. Bolt  
Ø8x35mm (12 pcs)

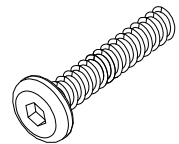

C. Spring Washer  
Ø8xØ12mm (17 pcs)



D. Flat Washer  
Ø8xØ19mm (17 pcs)



E. Bracket Metal (1 pc)

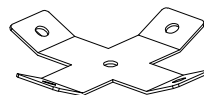

F. Allen Key (1 pc)

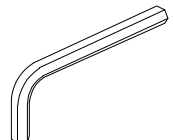

# ASSEMBLY INSTRUCTIONS

1

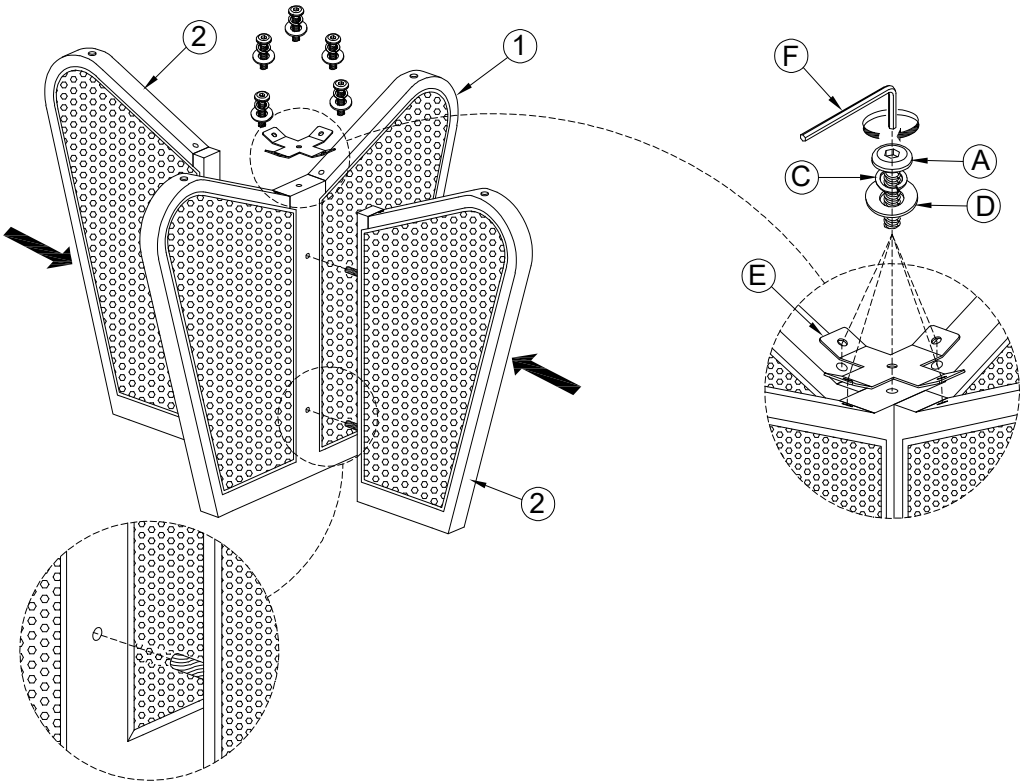

2

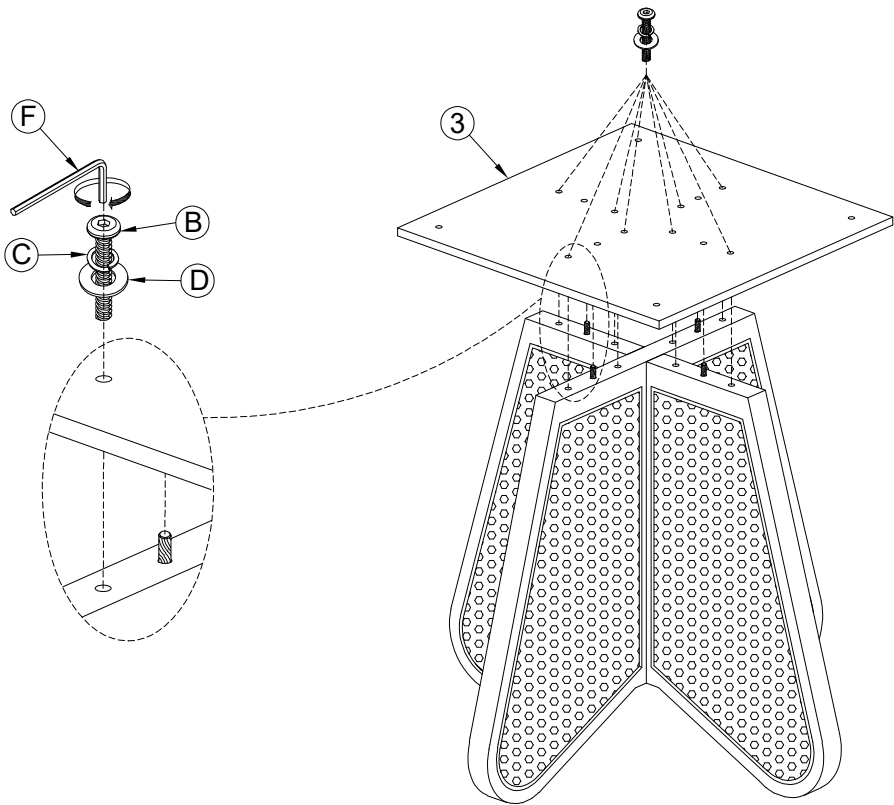

# ASSEMBLY INSTRUCTIONS

3

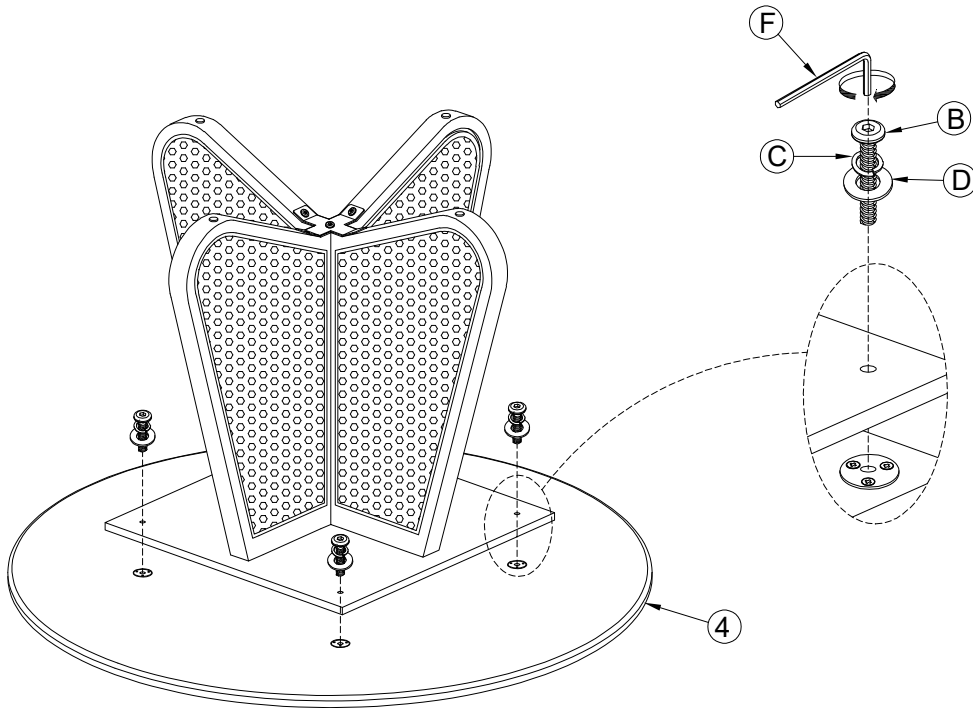

4

