



Assembly Instructions

General Information

PLEASE READ THROUGH BEFORE BEGINNING ASSEMBLY.

IMPORTANT: Check boxes for Contents Listed

Check inside of parts as some parts are packaged inside of others

In the event of missing, damaged or defective parts please call our customer service dept. at 1-877-258-6020

When assembling components, place on a clean, flat non-abrasive surface to avoid scratches

Tools Required

- ... Battery or Electric Drill with #2 phillips bit
- ... Tape Measure
- ... Hammer or Rubber Mallet (recommended)
- ... PVC, Super, or Crazy Glue

<u>Part #</u>	<u>Description</u>	<u>Qty</u>
1	2" sq. x 74" Left Post	1
2	2" sq. x 74" Right Post	1
3	7/8 x 1 1/2 x 27 1/2" Outer Cross Rail	2
4	7/8 x 1 1/2 x 27 1/2" Inner Cross Rail	4
5	7/8 x 1 1/2 x 27 1/2" Middle Cross Rail	2
6	1 x 1 x 26 1/2" Vertical Rail	4
7	1 x 1 x 16 3/4" Vertical Rail	4
8	1 x 1 x 13" Vertical Rail	2
9	14" Ground Anchor	2
10	Hardware Bag (includes:)	1
	2" sq. Post Cap	2
	3/4" Painted Screw	8
	#8 - 1" Painted Self Tapping Screw (for ground anchors)	4

Warranty Statement

20 Year Guarantee

Please call manufacturer direct with questions concerning missing or defective parts at Toll Free:

Products are warranted to be free from manufacturing defects resulting in delaminating, peeling, flaking, corroding, cracking, crazing, or extreme amounts of fading or bleaching causing the PVC to change to its natural color for a period of 20 years from the date of purchase.

Normal weathering is defined as exposure to sunlight and extremes of weather and atmosphere which will cause any colored surface to gradually fade.

CONDITIONS NOT COVERED BY THIS WARRANTY:

- A. Physical abuse, misuse, neglect, or improper storage.
- B. Improper installation or installation not in strict adherence to the instructions written Inc.
- C. This warranty does not apply if materials are painted, varnished, or coated with any substance.
- D. Dura-Trel, Inc. is not responsible for damages to product during shipping.
- E. Damage attributable to atmospheric pollutants, hail, lightning, hurricane, tornado, wind borne objects, earthquake, fire, mildew, casualty, act of God, building or ground settlement, or subjection to stress or weight.

CLAIMS AND REMEDIES:

If a product is determined to have a manufacturing defect which is covered by this warranty, Inc. will replace the material containing the defect (labor not included) F.O.B from the point of manufacture, Inc. will not be responsible for any cost incurred in the removal or reinstallation of the product.

Important: An claims must be sent to the following address and should describe the defect claim.

Inc. reserves the right to discontinue or change its design, and or color. If the original color or style is not available, Inc. shall have the right to substitute a product designated by Inc. Inc. shall not be liable for any incidental, special, or consequential damages arising out of the use of these products

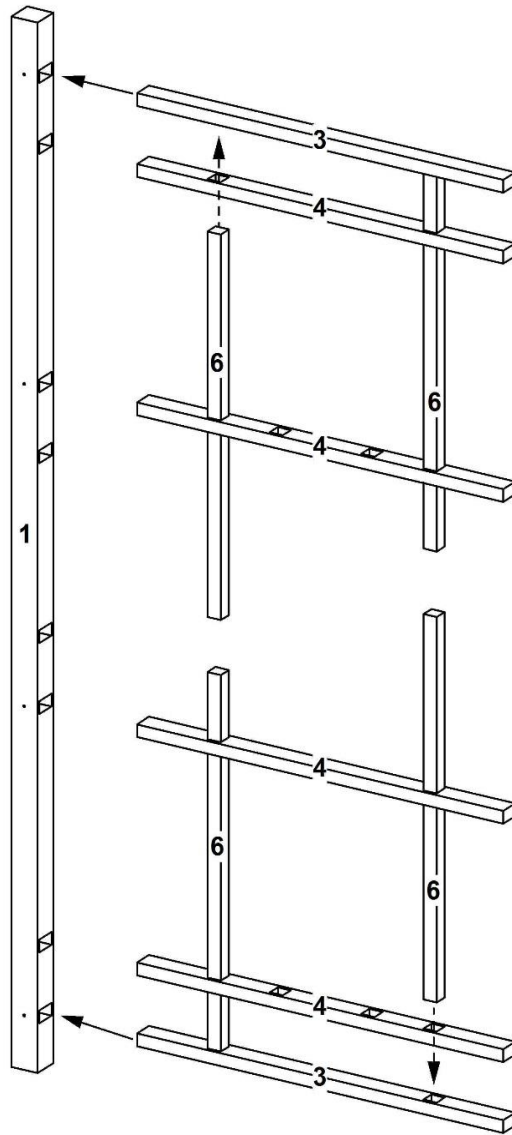

Starting at bottom of 74" left post (part 1), insert one 27½" outer cross rail (part 3) and two 27½" inner cross rails (part 4). When inserting two inner cross rails insert sides with four routed holes facing each other. Insert two 26½" vertical rails (part 6) through outer holes of inner cross rails and into outer holes of outer cross rail.

Starting at top of same 74" left post, insert another 27½" outer cross rail (part 3) and two more 27½" inner cross rails (part 4). When inserting two inner cross rails insert sides with four routed holes facing each other. Insert to 26½" vertical rails (part 6) through outer holes of inner cross rails and into outer holes of outer cross rail.

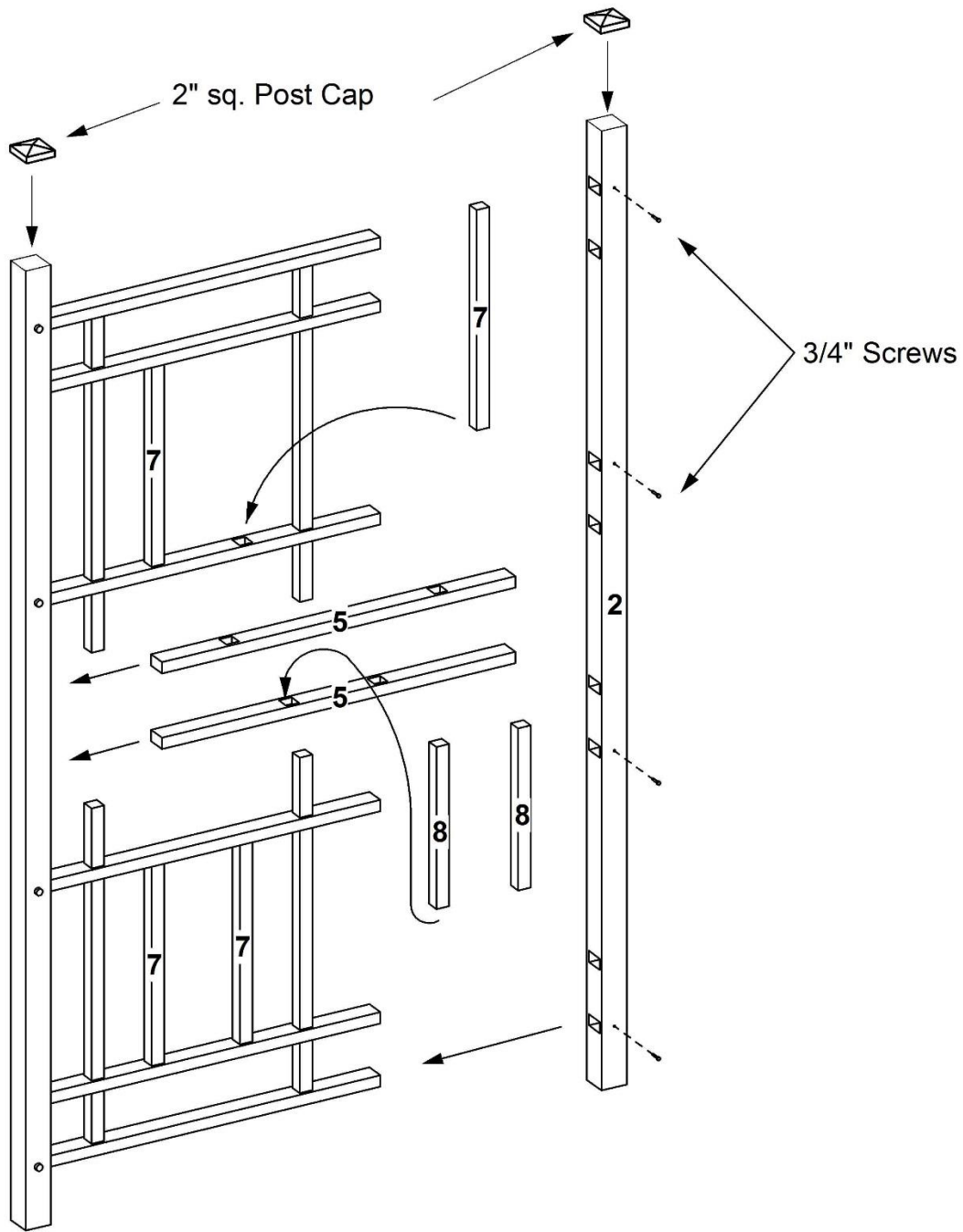

Insert two 27½" middle cross rails (part 5) into remaining routed holes in side of post, inserting free ends of 26½" vertical rails into middle cross rail. Insert four 16¾" vertical rails (part 7) into remaining holes in inside cross rails. Insert two 13" vertical rails (part 8) into remaining holes in middle cross rails. Insert free ends of cross rails into 74" right post (part 2).

Using four ¾" screws per post, fasten together trellis. Be sure all parts are fully inserted into posts before securing. Using PVC, super or crazy glue, apply glue to inside corners and place on top of each post.

Figure 1

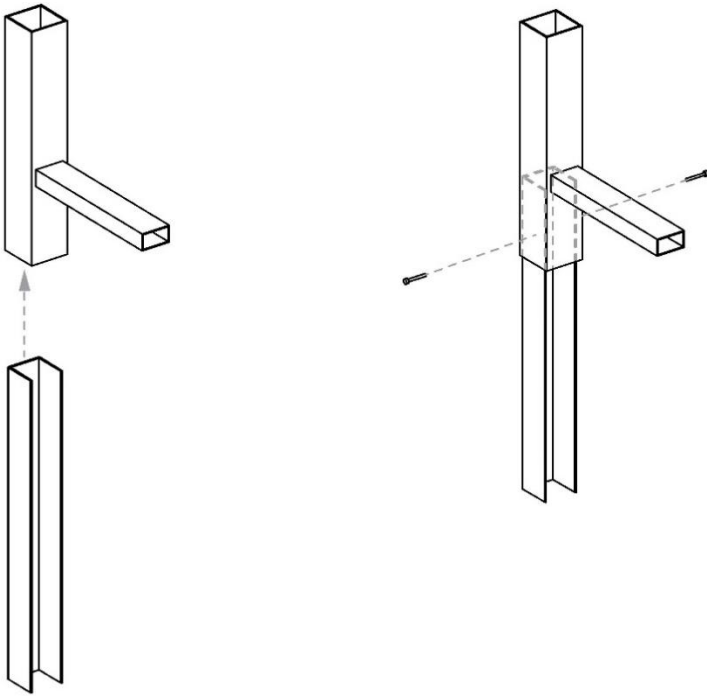
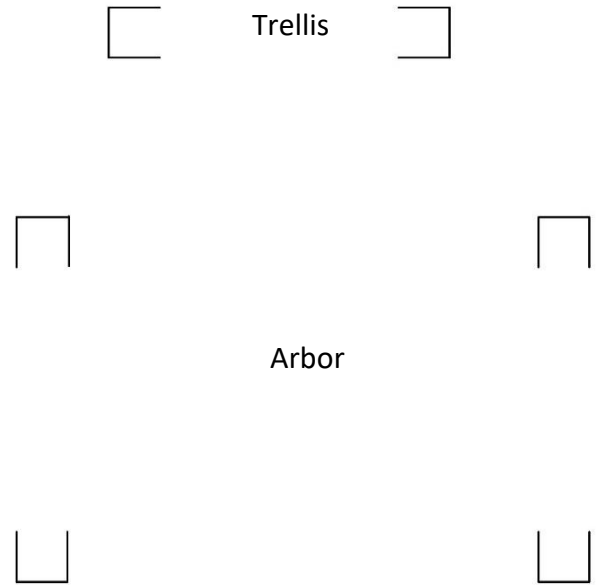

Figure 2



Option 1 (soft ground)

Slide one 16 inch ground anchor into bottom of each post. Slide ground anchor up to bottom cross rail. Using two 1 inch self-tapping screws per post, screw the post to the ground anchor (figure 1). When fastening, use one screw on each opposite side as shown in the drawing. Once ground anchors are attached to posts, push trellis/arbor into ground. This method can also be used for installation into hard ground if area thoroughly drenched with water.

Option 2 (hard ground)

Measure distances between posts and mark ground accordingly. Pound 16 inch ground anchor into ground according to measurements and basic layout (figure 2), leaving about 4 inches of ground anchor exposed. When pounding into ground, use a block of wood to prevent ground anchor from cracking.

Slide trellis/arbor over ground anchors. Using two 1" self-tapping screws per post, screw the post to the ground anchor (figure 1). When fastening, use one screw on each opposite side as shown in the drawing.

Option 3 (permanent installation)

Measure distances between posts and mark ground accordingly. Dig holes 12 inches according to measurements and basic layout (figure 2). Fill with cement and place 16 inch ground anchor in wet cement. Be sure that ground anchors are straight and in accordance with measurements of trellis/arbor posts. Allow cement to dry. NOTE: There is very little room for error with this installation method.

Slide trellis/arbor over ground anchors. Using two 1" self-tapping screws per post, screw the post to the