

ASSEMBLY INSTRUCTIONS

BUNK BED WITH TRUNDLE

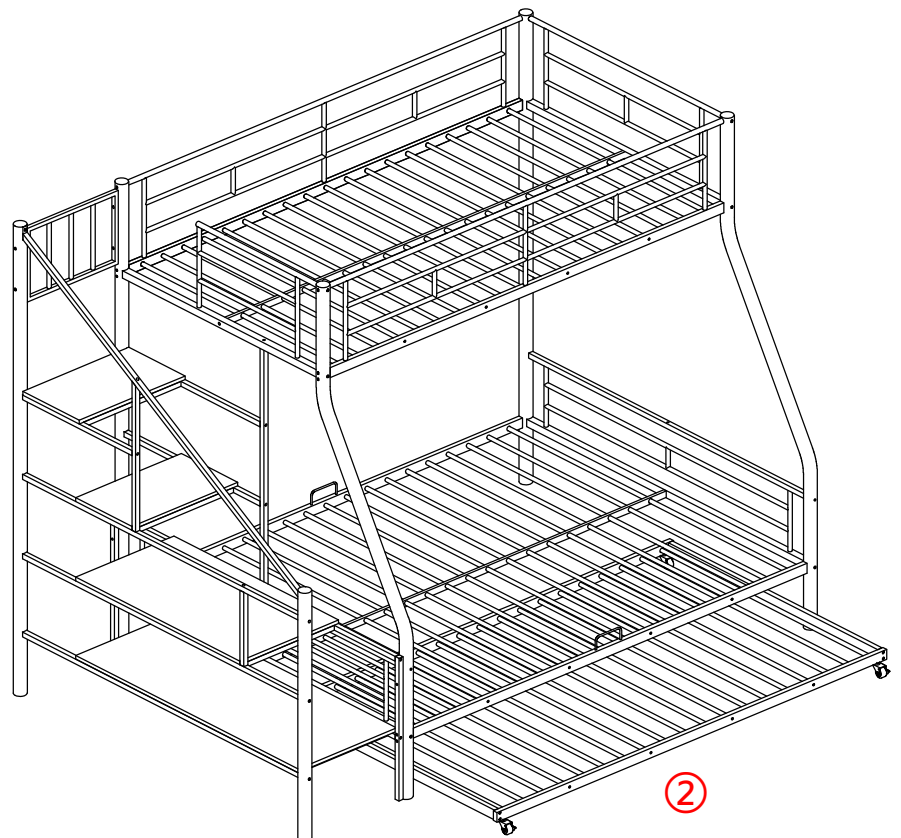
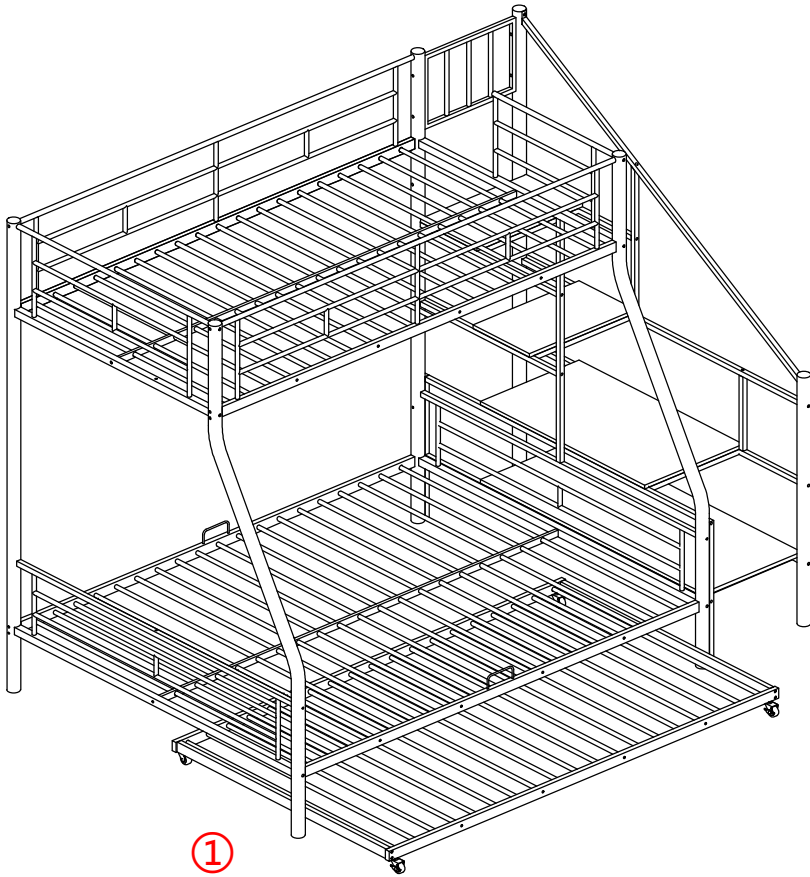

WF310919/310920

SAFETY WARNINGS AND GENERAL NOTES:

1. Follow the information on the warnings on the upper bunk bed end structure and on the carton. Do not remove the warning label from the bed.
2. Always use the recommended size mattress or mattress support, or both, to help prevent the likelihood of entrapment or falls.
3. Do not allow children under 6 years of age to use the upper bunk.
4. Periodically check and ensure the guardrail, ladder and other components are in their proper position, free from damage, and all connectors are tight.
5. Do not allow horseplay on or under beds.
6. Always prohibit jumping on the bed.
7. Prohibit more than one person on upper bunk.
8. Always use the ladder for entering and leaving the upper bunk.
9. Do not use substitute parts. Contact the manufacturer or dealer for replacement parts.
10. Use of a night light may provide added safety precaution for a child using the upper bunk.
11. Always use guardrails on both long sides of the upper bunk.
12. If the bunk bed will be placed next to a wall, the guardrail that runs the full length of the bed should be placed against the wall to prevent entrapment between the bed and the wall. The use of water or sleep flotation mattresses is prohibited.
13. **STRANGULATION HAZARD**-Never attach or hang items to any part of the bunk bed that are not designed for use with the bed; for example, but not limited to, hooks, belts and jump ropes.
14. Keep these instructions for future reference.
15. We recommend assembling your bunk bed on the shipping carton to protect your floor or carpet.
16. Be certain all staples are out of the box before beginning assembly on the shipping carton.
17. **USE ONLY MATTRESSES WHICH ARE AS THE TABLE BELOW ON UPPER AND ON LOWER BUNKS.**

Lower bed

Bed type	Length	Width	Thickness
Full Standard	74-75"	53-1/2"	6"

Upper bed(bunk bed and tribed included)

Bed type	Length	Width	Thickness
Twin Standard	74-75"	38-1/2"	6" max



18. **SURFACE OF MATTRESS MUST BE AT LEAST 5" (127MM) BELOW THE UPPER EDGE OF GUARDRAILS.**

19. Replacement Parts:

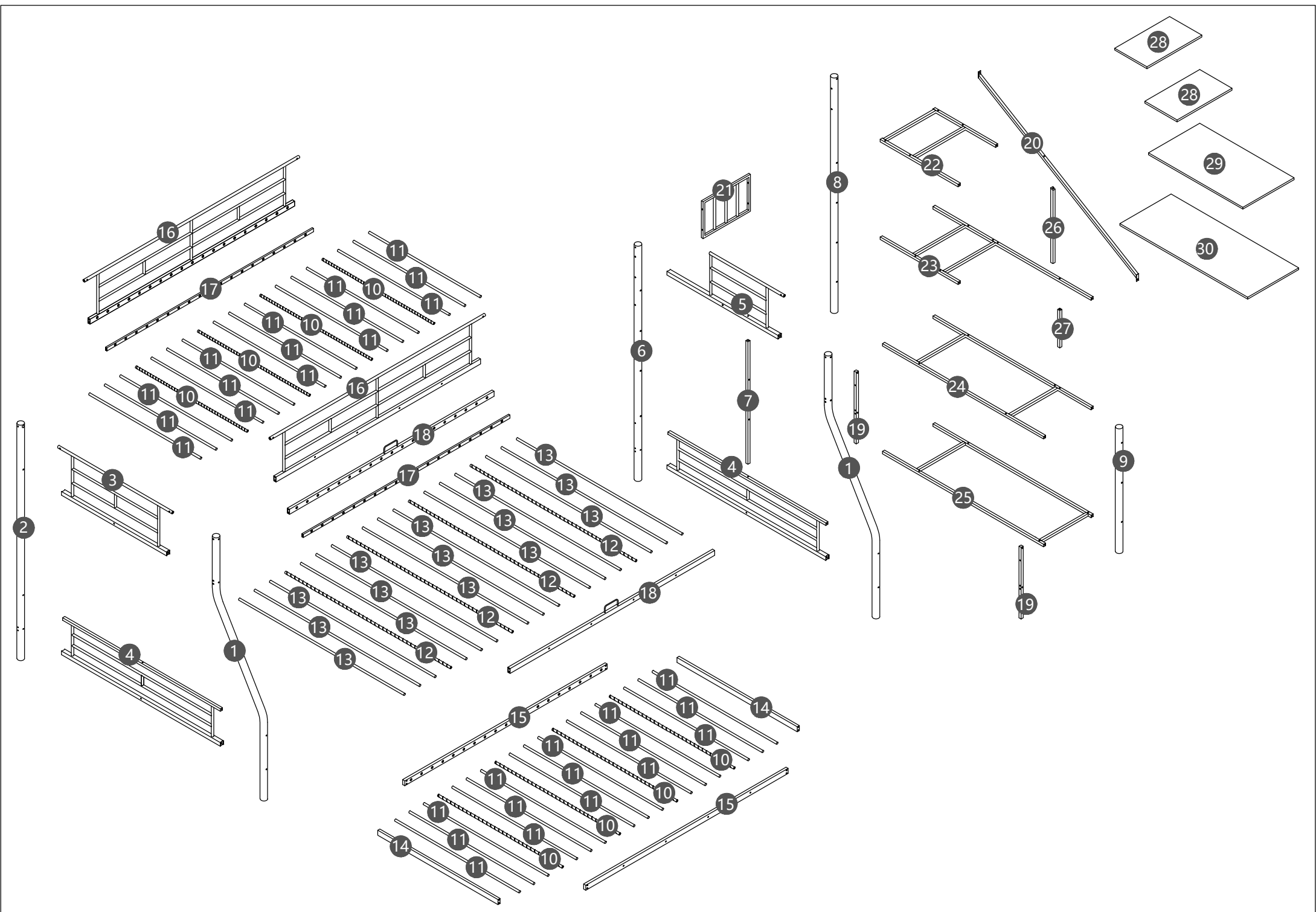

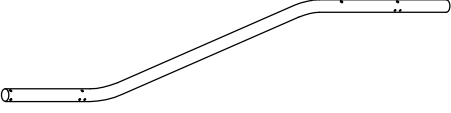

Replacement Parts, including additional guardrails, may be obtained from any of our (GIGACLOUD TECHNOLOGY (USA) INC) dealers.

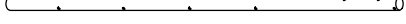
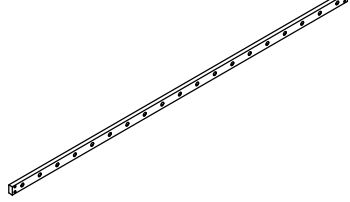
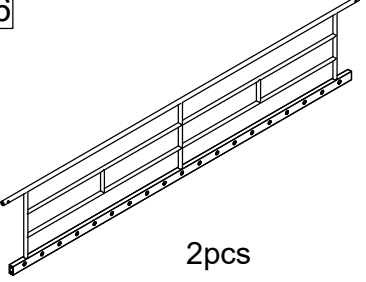
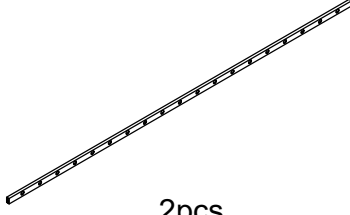
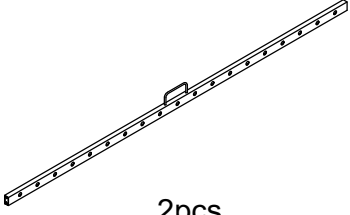
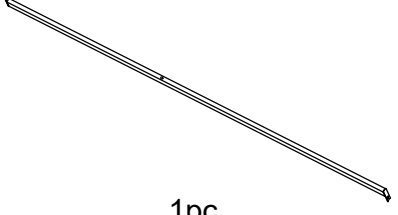



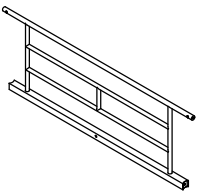
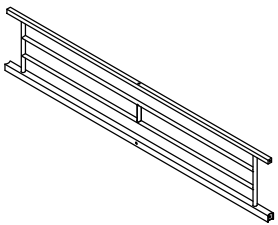
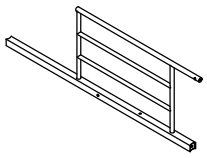

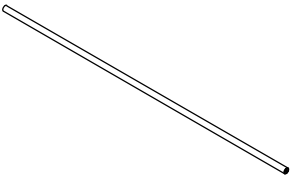
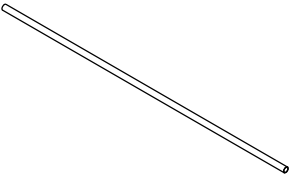
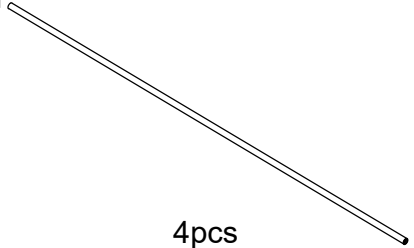
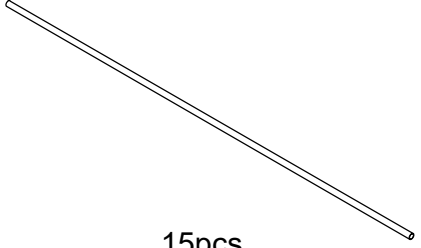
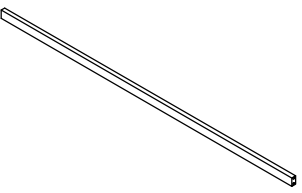
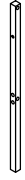
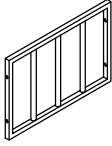
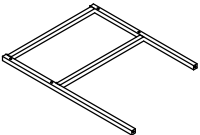
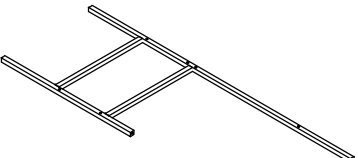
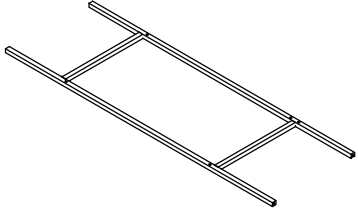
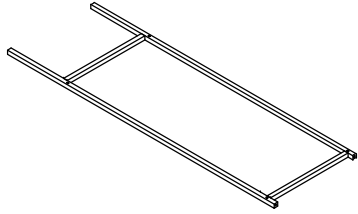
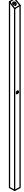

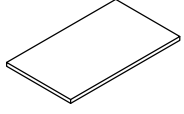
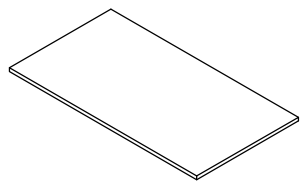
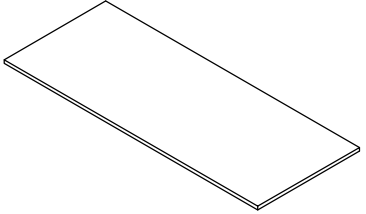



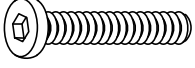

Parts List for WF310919

<p>1</p>  <p>2pcs</p>	<p>2</p>  <p>1pc</p>	<p>6</p>  <p>1pc</p>
<p>8</p>  <p>1pc</p>	<p>15</p>  <p>2pcs</p>	<p>16</p>  <p>2pcs</p>
<p>17</p>  <p>2pcs</p>	<p>18</p>  <p>2pcs</p>	<p>20</p>  <p>1pc</p>

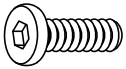

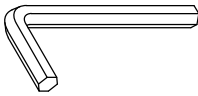
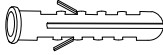
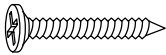
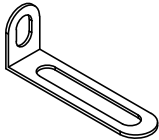
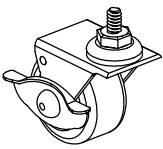
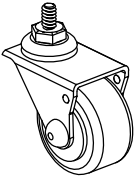
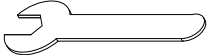
Parts List for WF310920

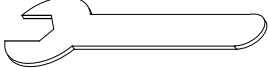
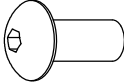
<p>3</p>  <p>1pc</p>	<p>4</p>  <p>2pcs</p>	<p>5</p>  <p>1pc</p>
<p>7</p>  <p>1pc</p>	<p>9</p>  <p>1pc</p>	<p>10</p>  <p>8pcs</p>
<p>11</p>  <p>30pcs</p>	<p>12</p>  <p>4pcs</p>	<p>13</p>  <p>15pcs</p>
<p>14</p>  <p>2pcs</p>	<p>19</p>  <p>2pcs</p>	<p>21</p>  <p>1pc</p>
<p>22</p>  <p>1pc</p>	<p>23</p>  <p>1pc</p>	<p>24</p>  <p>1pc</p>
<p>25</p>  <p>1pc</p>	<p>26</p>  <p>1pc</p>	<p>27</p>  <p>1pc</p>
<p>28</p>  <p>2pcs</p>	<p>29</p>  <p>1pc</p>	<p>30</p>  <p>1pc</p>

Hardware List for WF310920



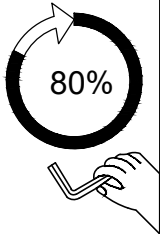
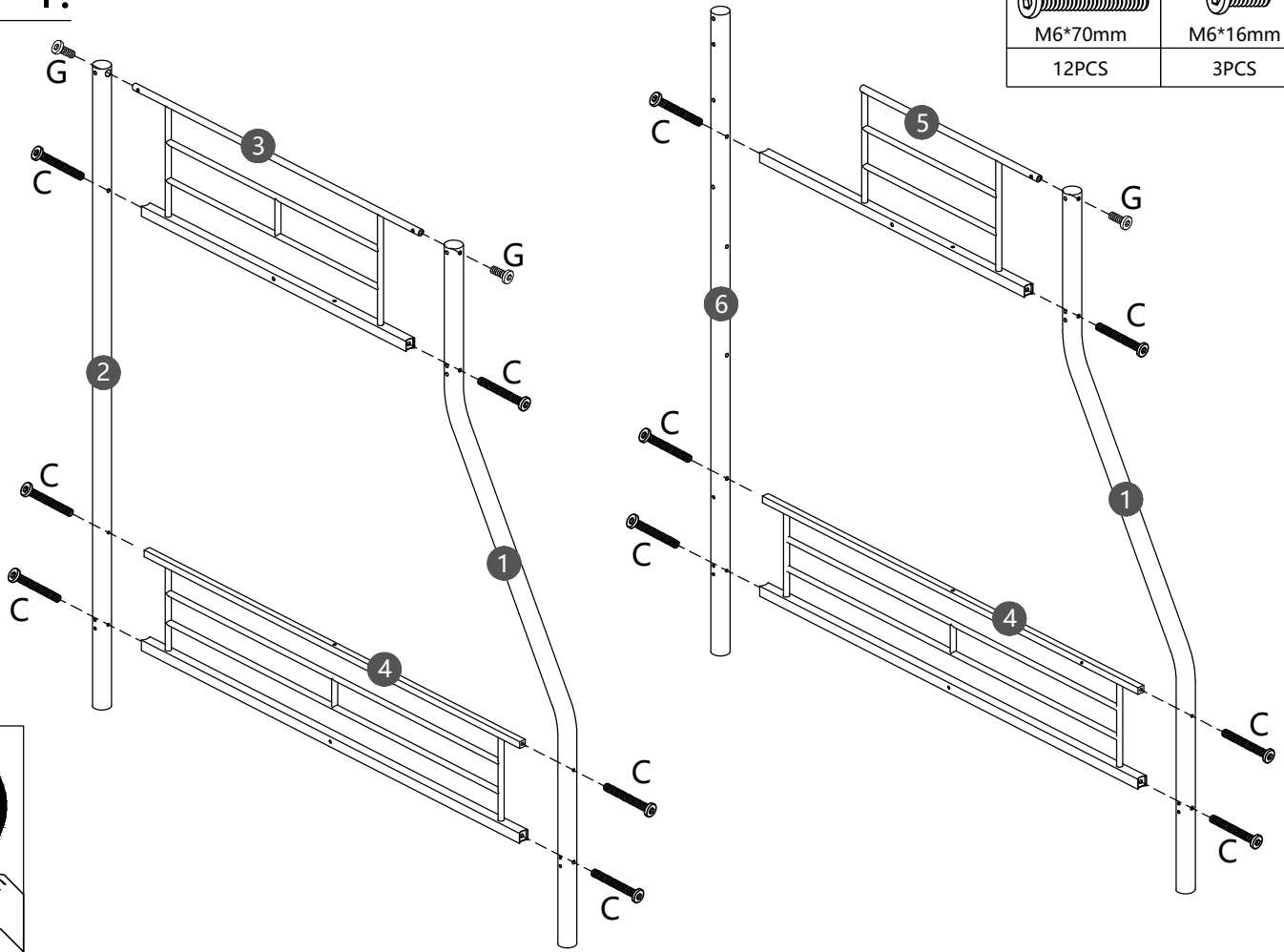

<p>A</p>  <p>M6*90mm 4pcs</p>	<p>B</p>  <p>M6*75mm 4pcs</p>	<p>C</p>  <p>M6*70mm 37pcs</p>
<p>D</p>  <p>M6*45mm 6pcs</p>	<p>E</p>  <p>M6*40mm 18pcs</p>	<p>F</p>  <p>M6*30mm 17pcs</p>
<p>G</p>  <p>M6*16mm 29pcs</p>	<p>H</p>  <p>M6 4pcs</p>	<p>I</p>  <p>2pcs</p>
<p>J</p>  <p>2pcs</p>	<p>K</p>  <p>2pcs</p>	<p>L</p>  <p>2pcs</p>
<p>M</p>  <p>2pcs</p>	<p>N</p>  <p>2pcs</p>	<p>O</p>  <p>1pc</p>
<p>P</p>  <p>M6*60mm 2pcs</p>	<p>Q</p>  <p>1pc</p>	<p>R</p>  <p>M6 2pcs</p>
<p>S</p>  <p>Ø4*14mm 2pcs</p>		

STEP 1:

C	G
 M6*70mm	 M6*16mm
12PCS	3PCS



STEP 2:

A	C
 M6*90mm	 M6*70mm
2PCS	8PCS
P	R
 M6*60mm	 M6
1PC	1PC

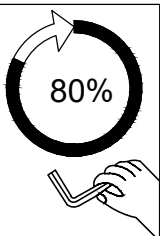
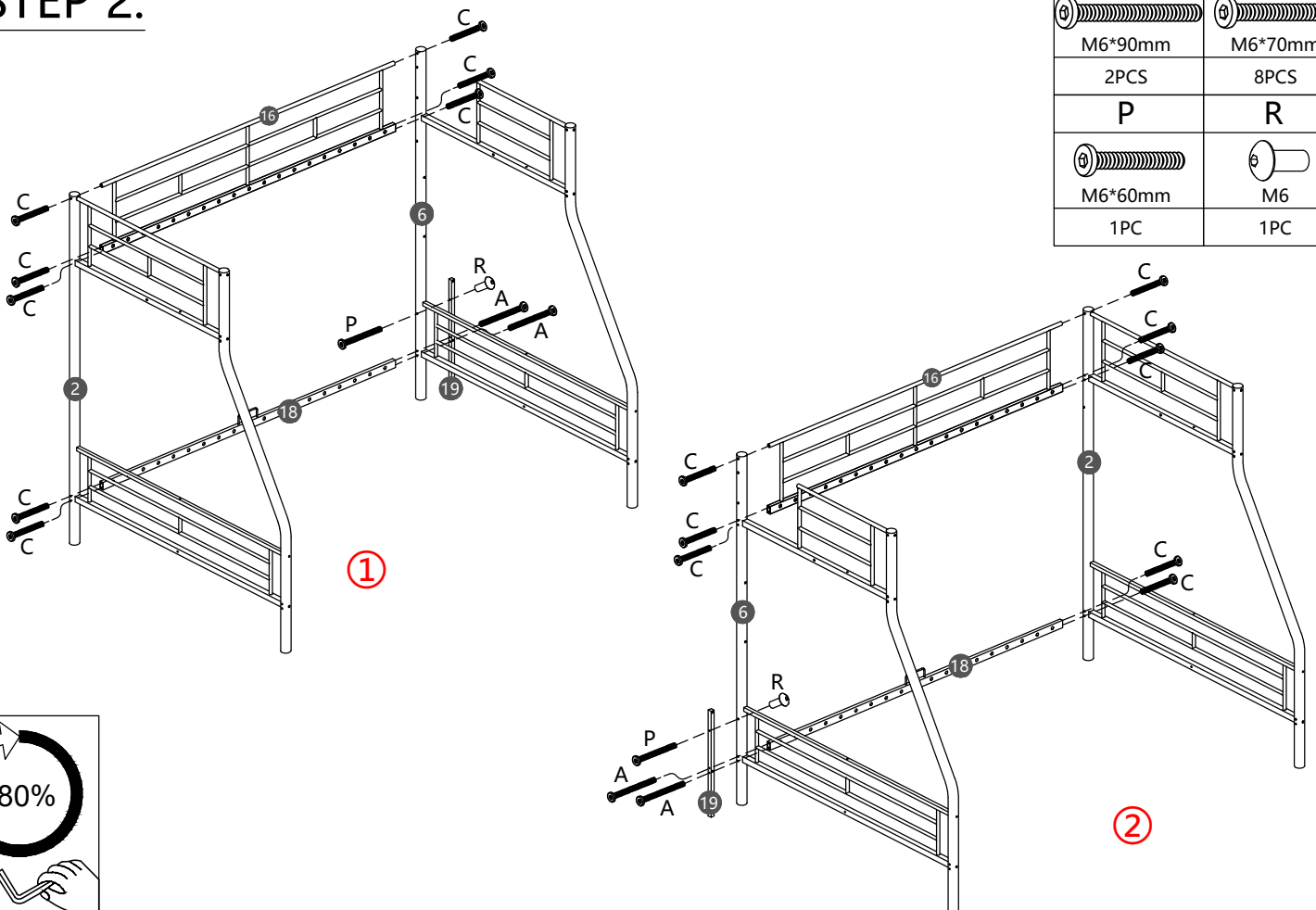

STEP 3:

D

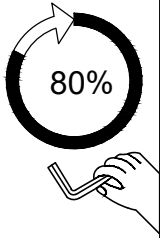
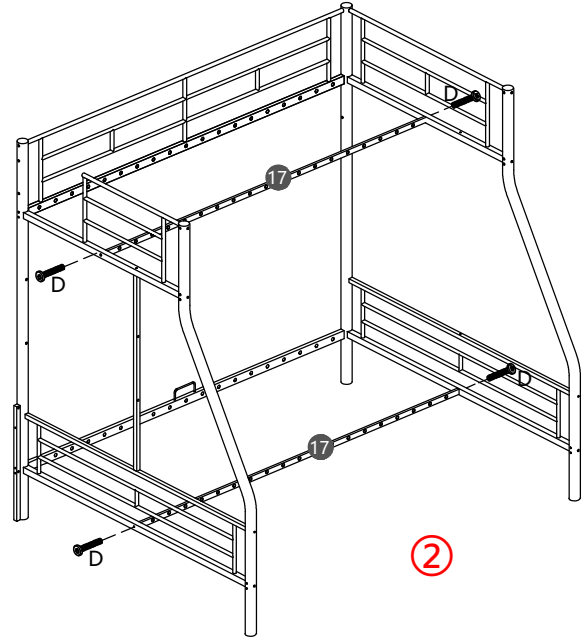
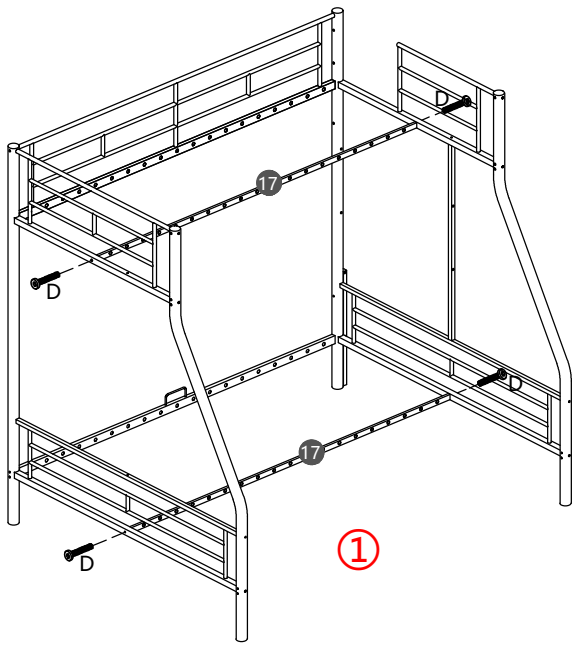
M6*45mm
4PCS

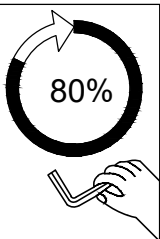
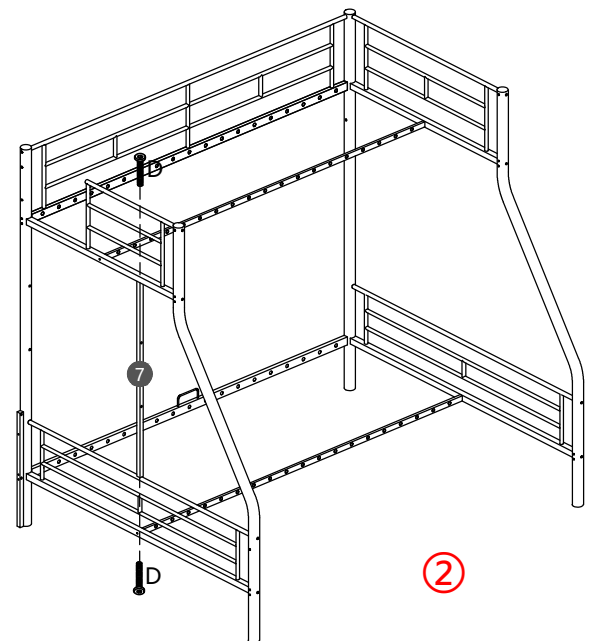
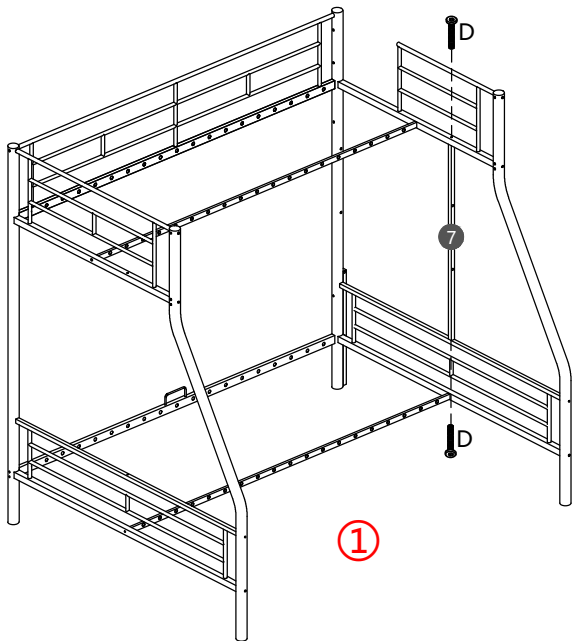

STEP 4:

D

M6*45mm
2PCS





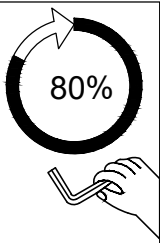
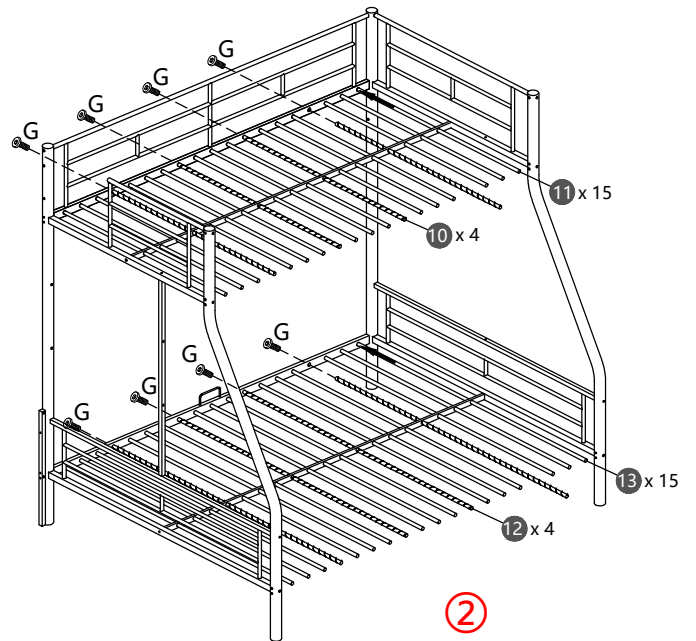
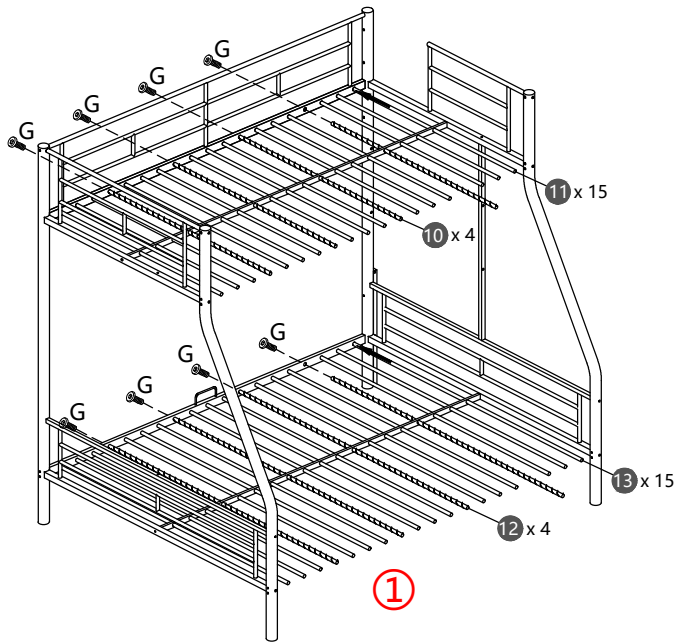

STEP 5:

G

M6*16mm
8PCS

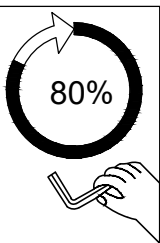
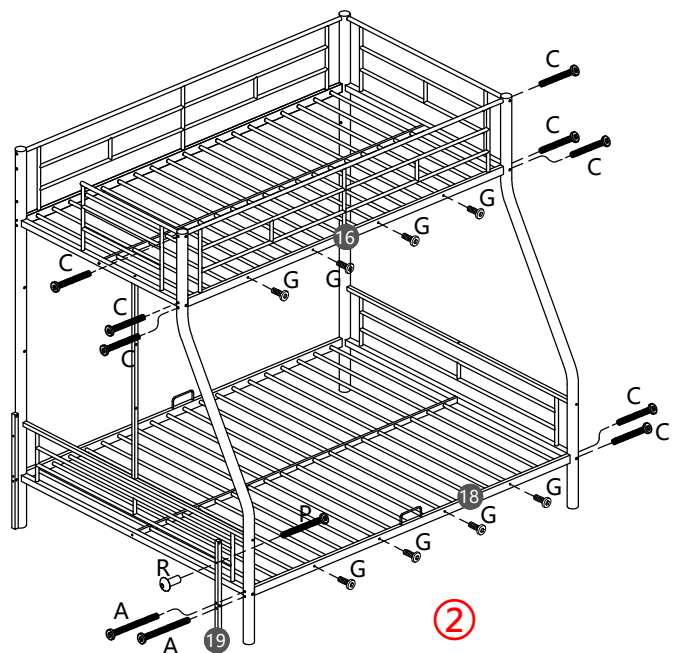
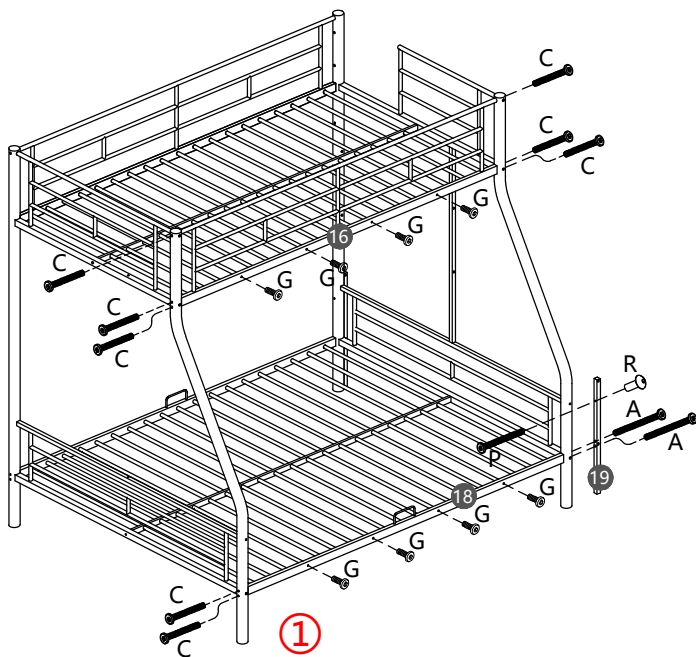

STEP 6:

A	C	G	R
			
M6*90mm	M6*70mm	M6*16mm	M6
2PCS	8PCS	8PCS	1PC
P			
			
M6*60mm			
1PC			



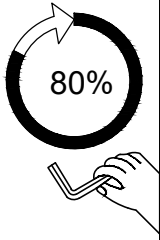
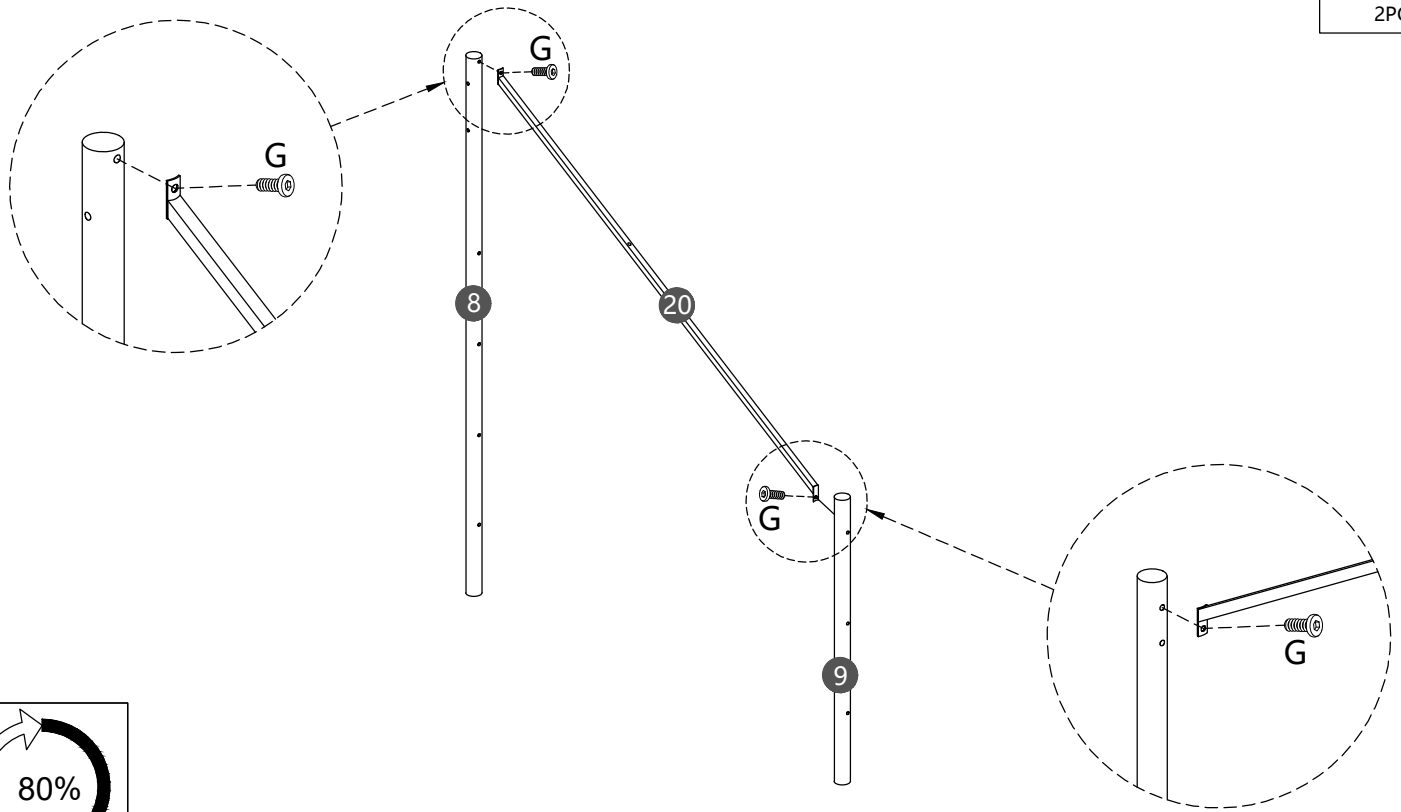

STEP 7:

G

M6*16mm
2PCS



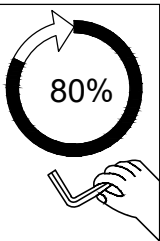
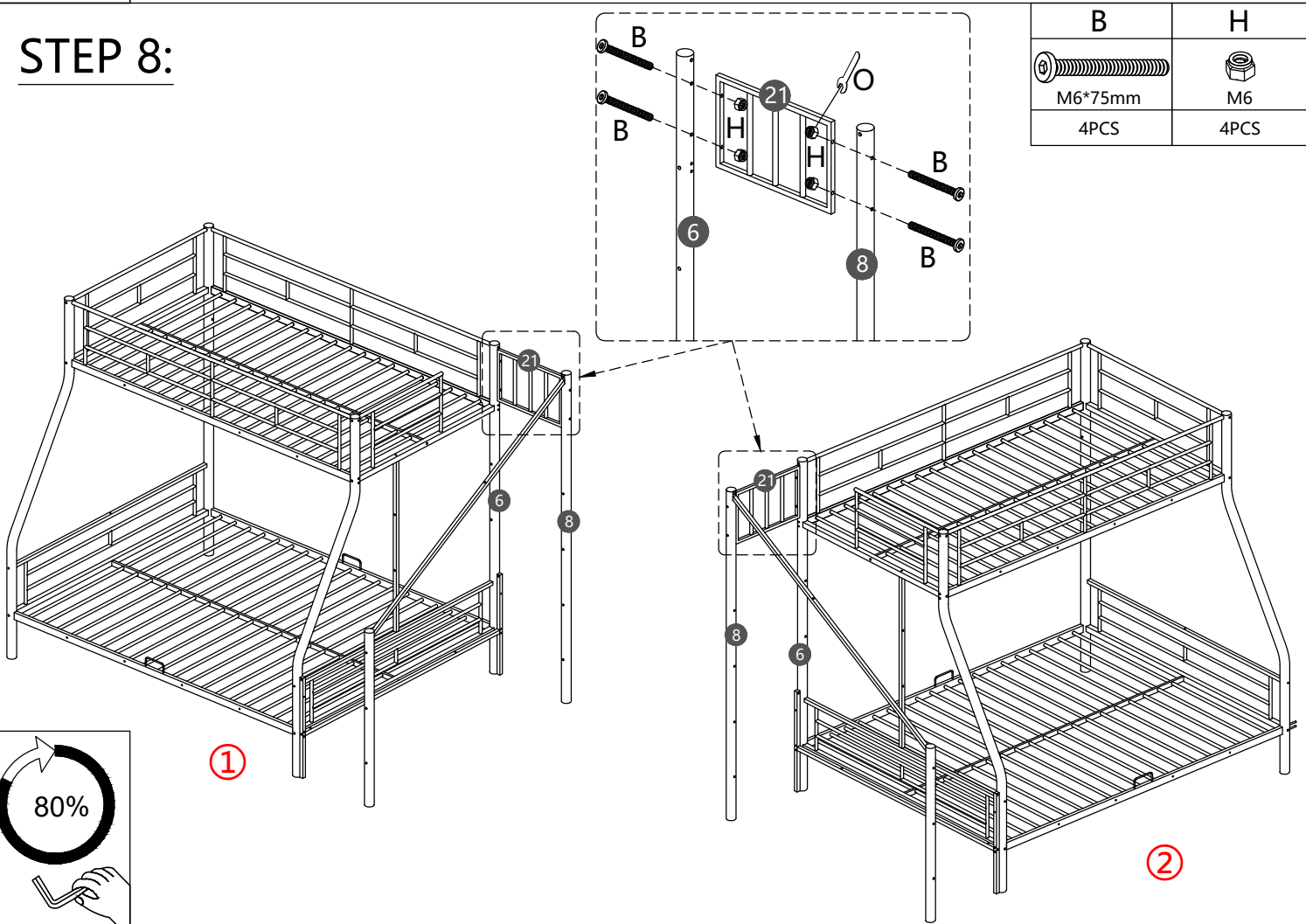

STEP 8:

B	H
	
M6*75mm	M6
4PCS	4PCS



STEP 9:

C	E
 M6*70mm	 M6*40mm
2PCS	1PC

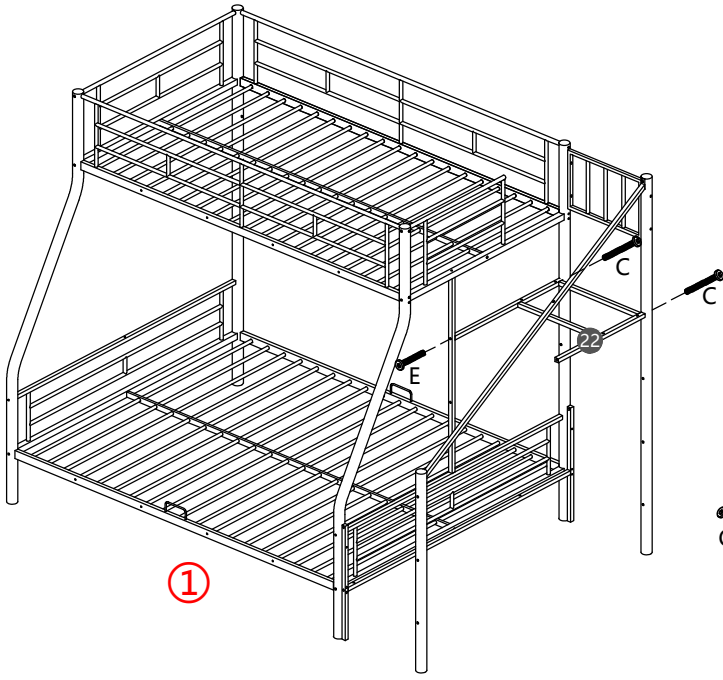

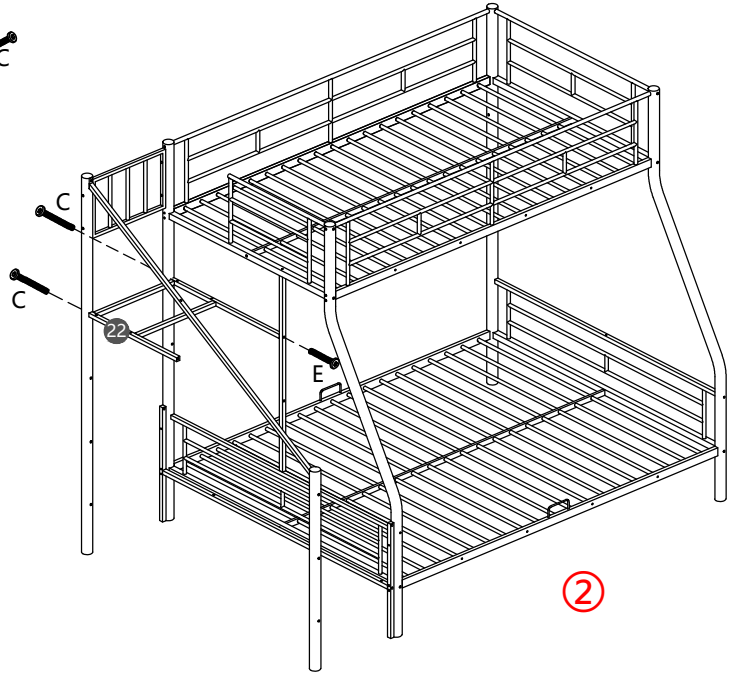

①

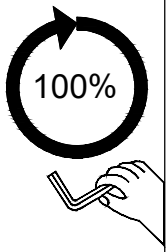

②



STEP 10:

C	E
 M6*70mm	 M6*40mm
3PCS	1PC

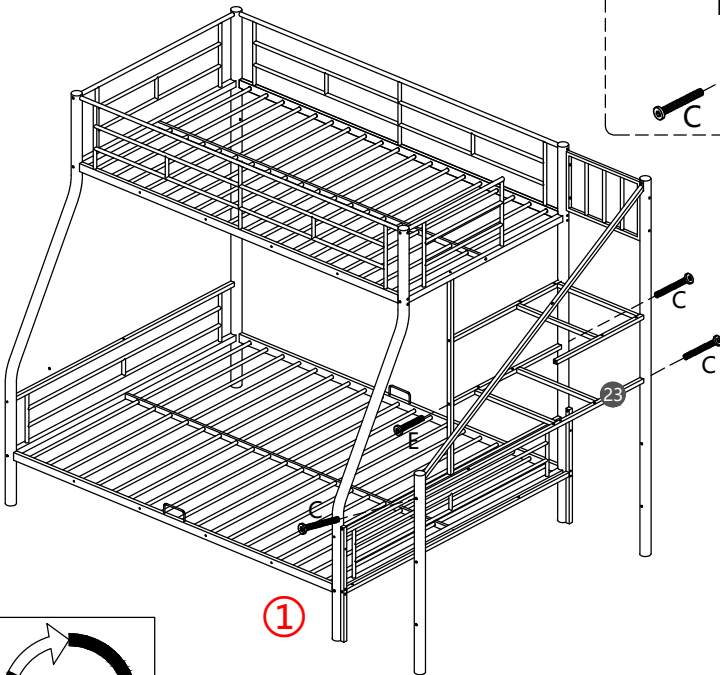
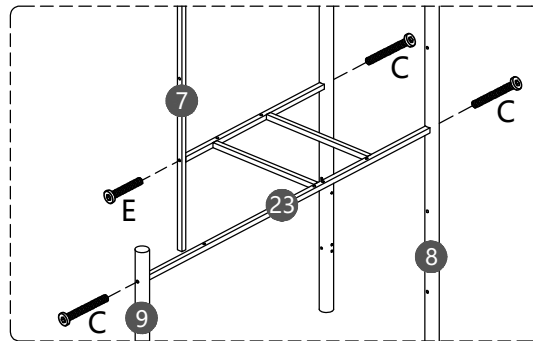

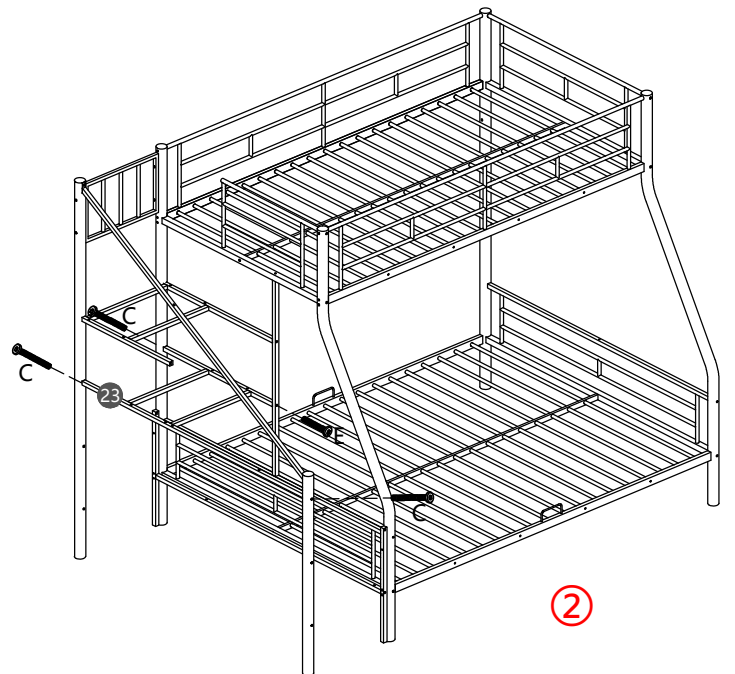

①

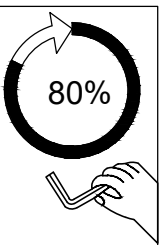

②



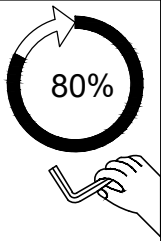
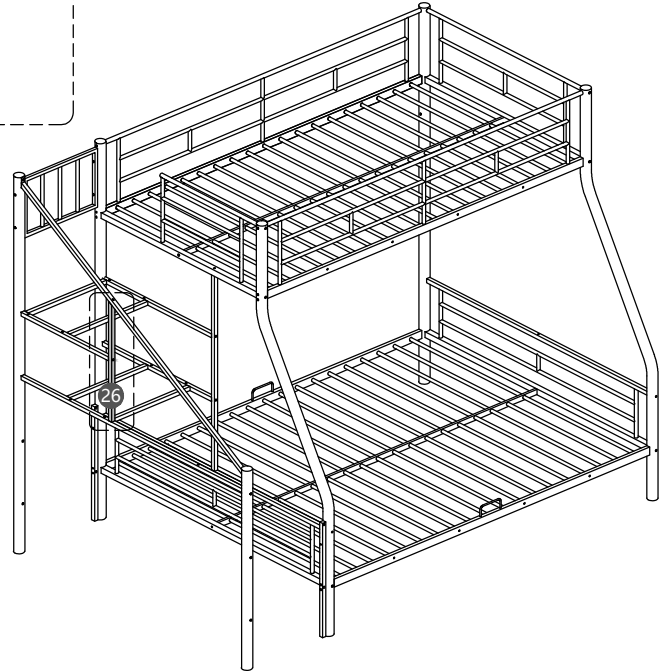
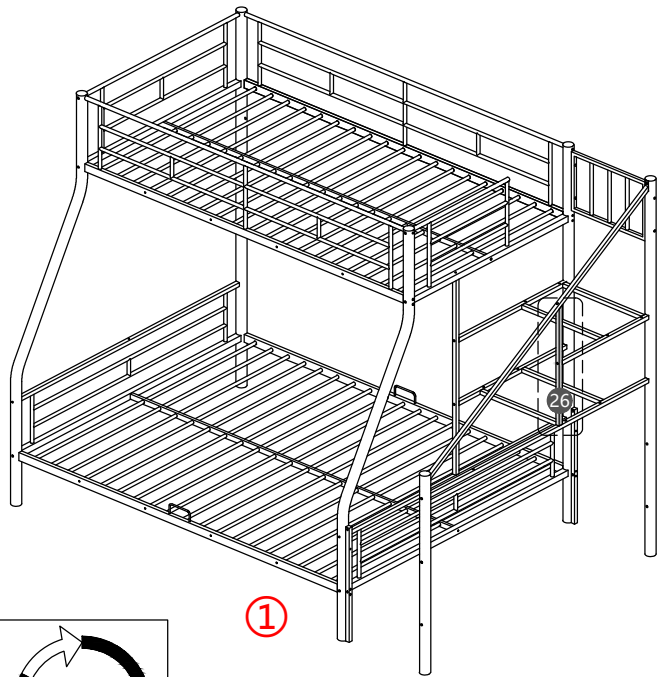

STEP 11:

E	F
 M6*40mm	 M6*30mm
2PCS	1PC



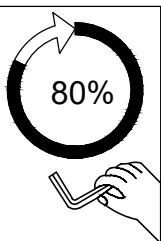
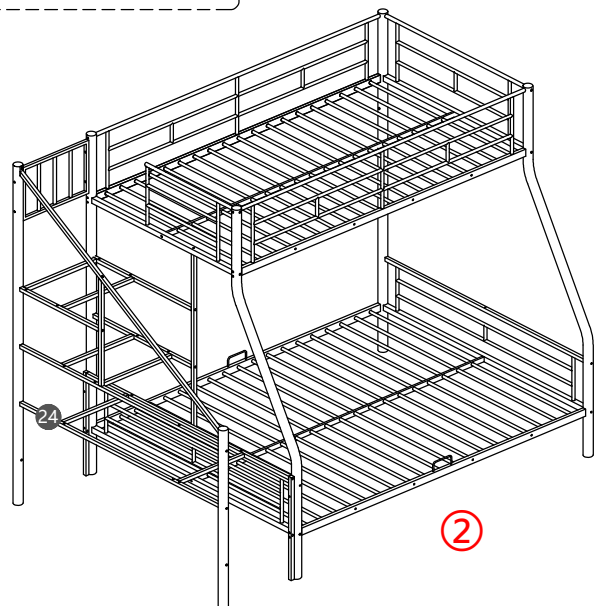
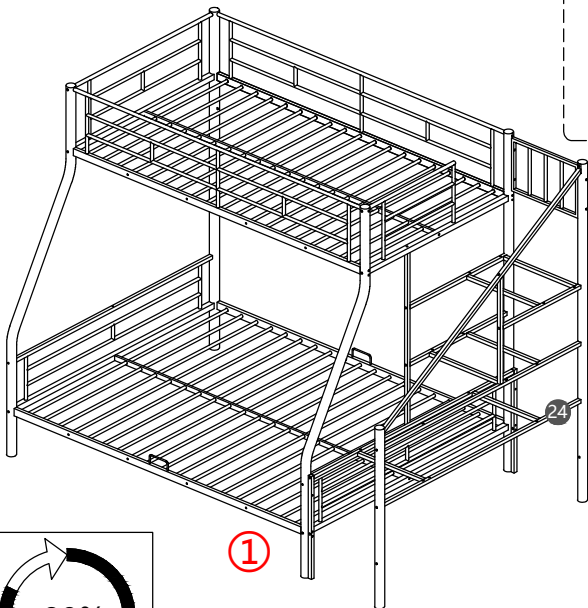
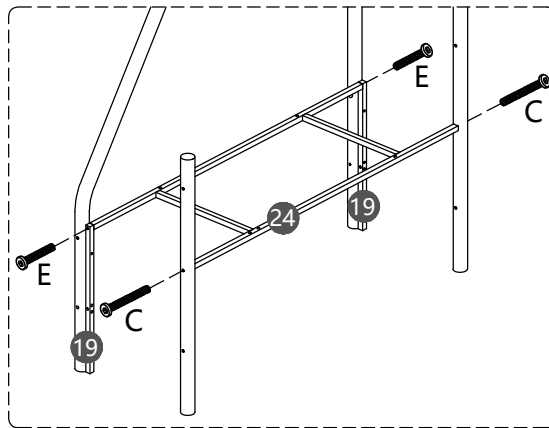

STEP 12:

C	E
 M6*70mm	 M6*40mm
2PCS	2PCS

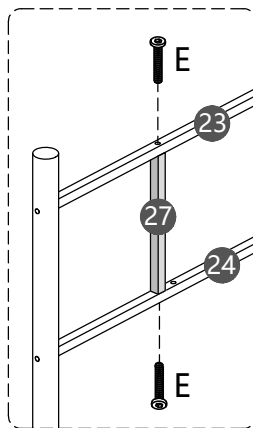
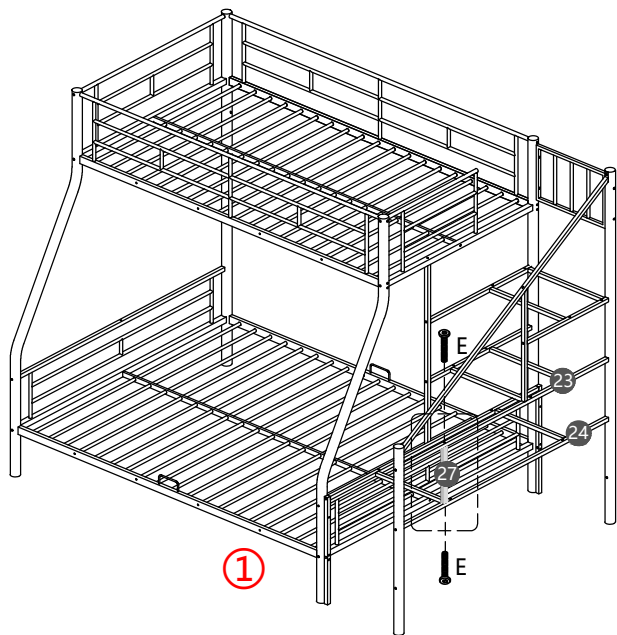

STEP 13:



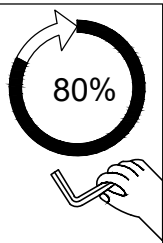
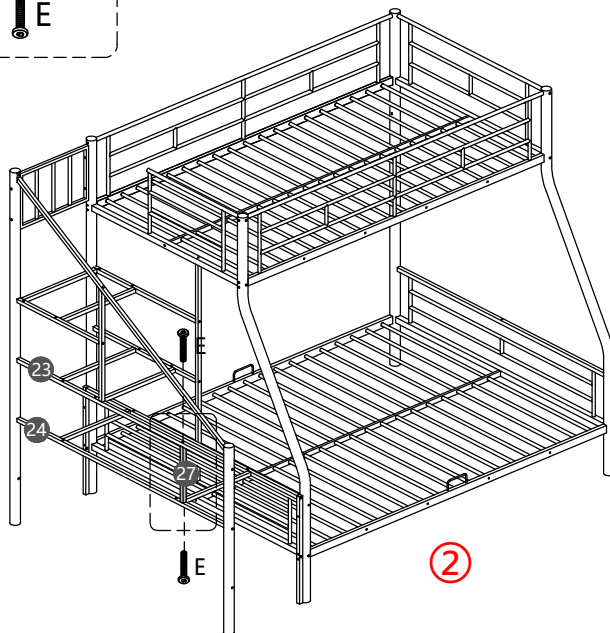

E

M6*40mm
2PCS

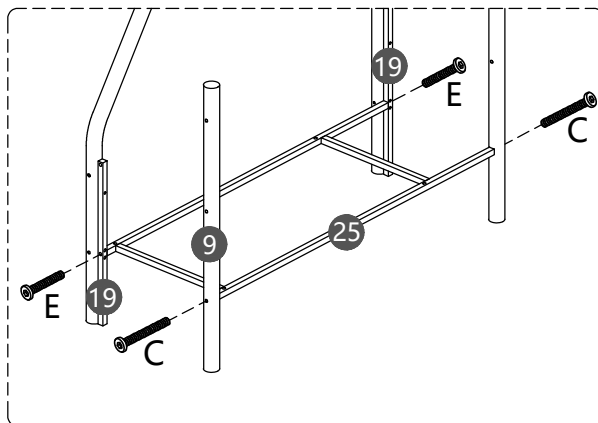
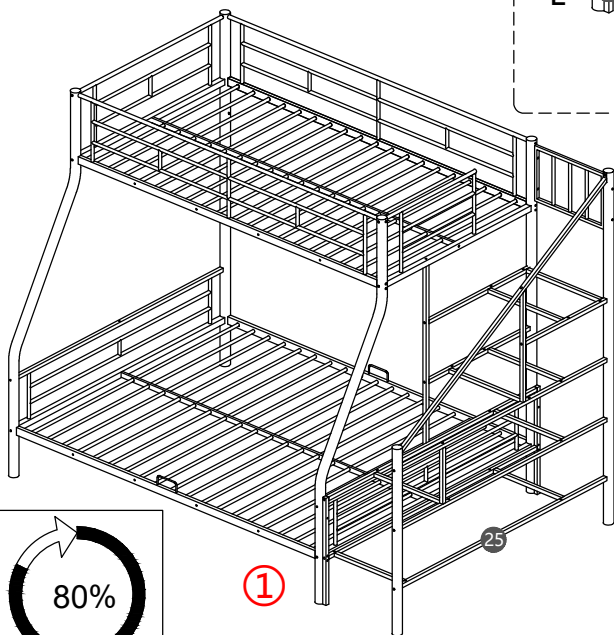

STEP 14:

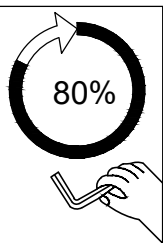
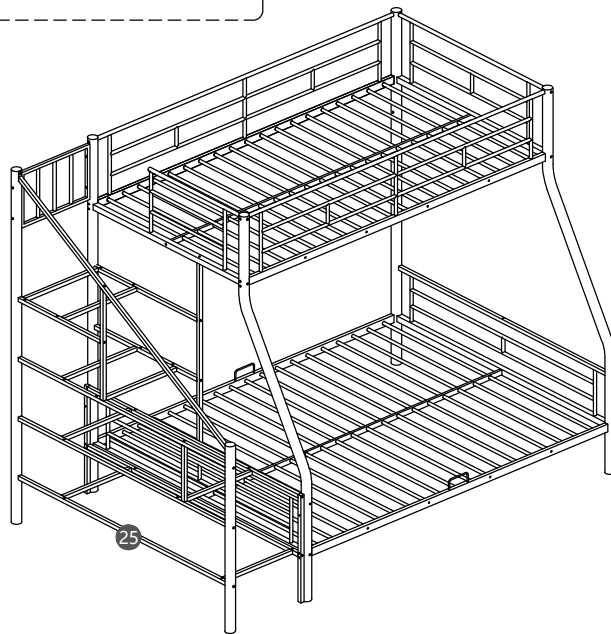

C	E
	
M6*70mm	M6*40mm
2PCS	2PCS



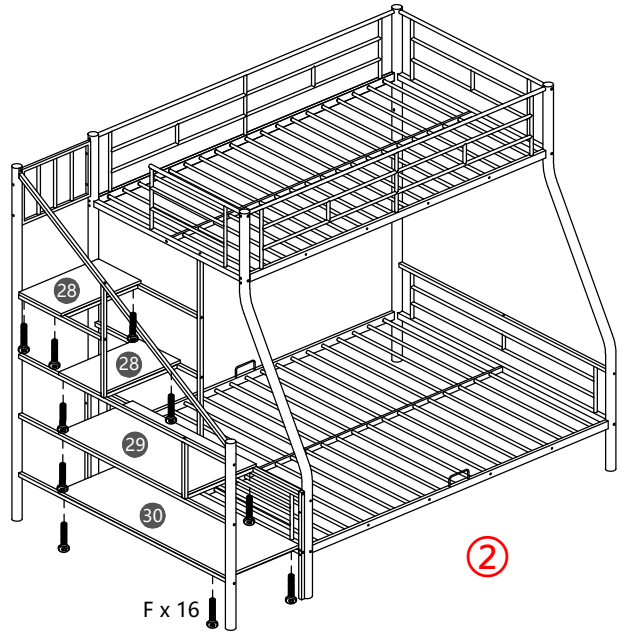
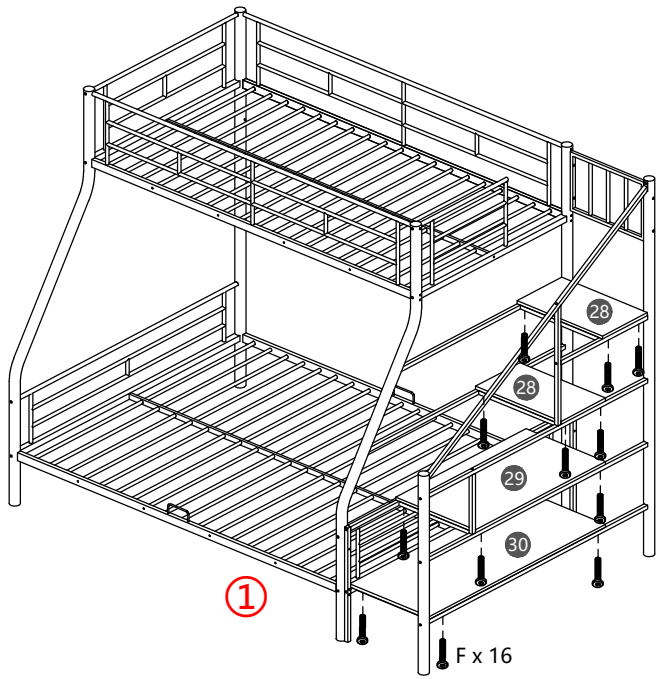

F

M6*30mm
16PCS

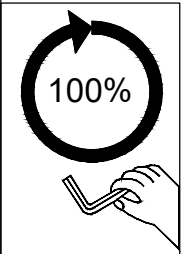

Tighten all the bolts.



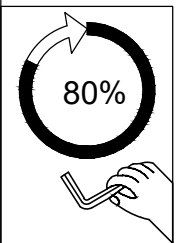
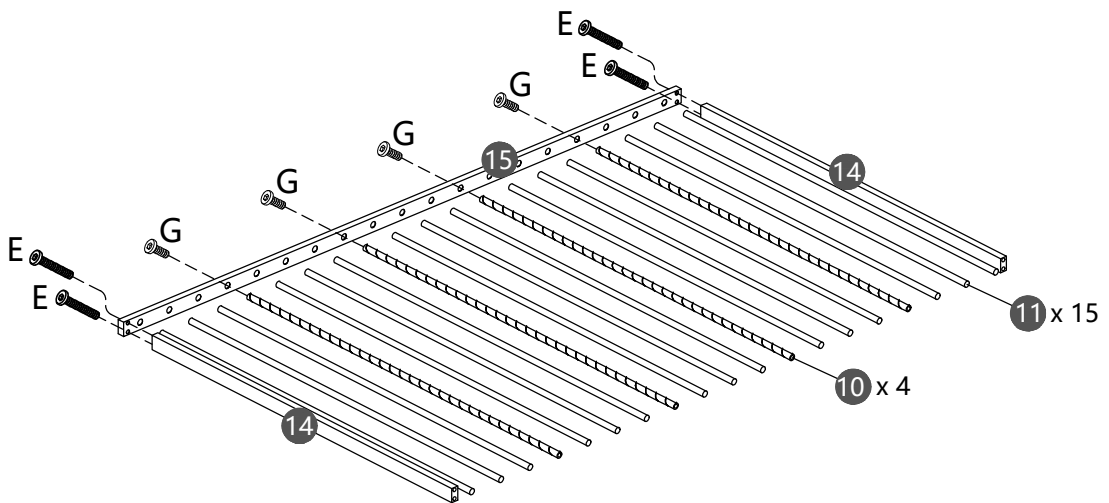

STEP 16:

E	G
	
M6*40mm	M6*16mm
4PCS	4PCS



STEP 17:

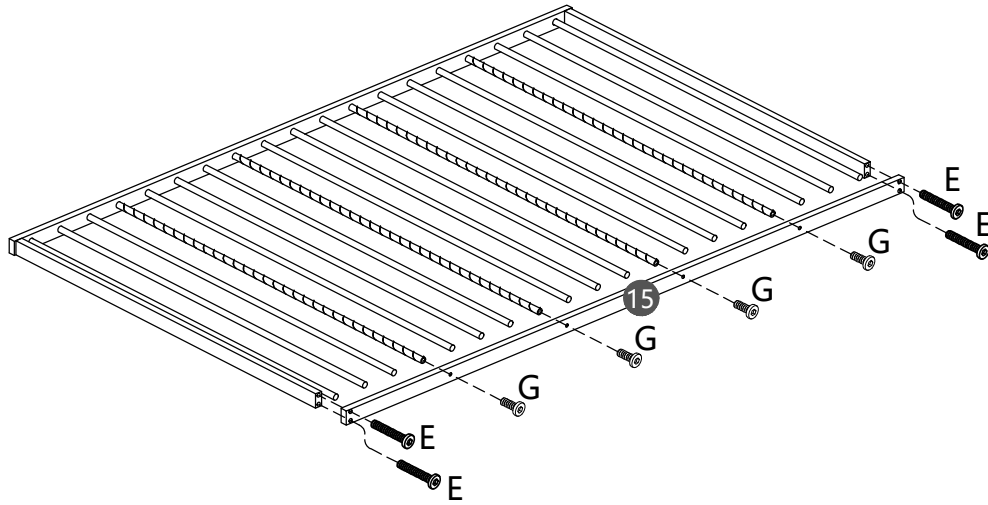

E	G
 M6*40mm	 M6*16mm
4PCS	4PCS

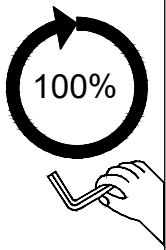

Tighten all the bolts.



STEP 18:

M	N
 2PCS	 2PCS

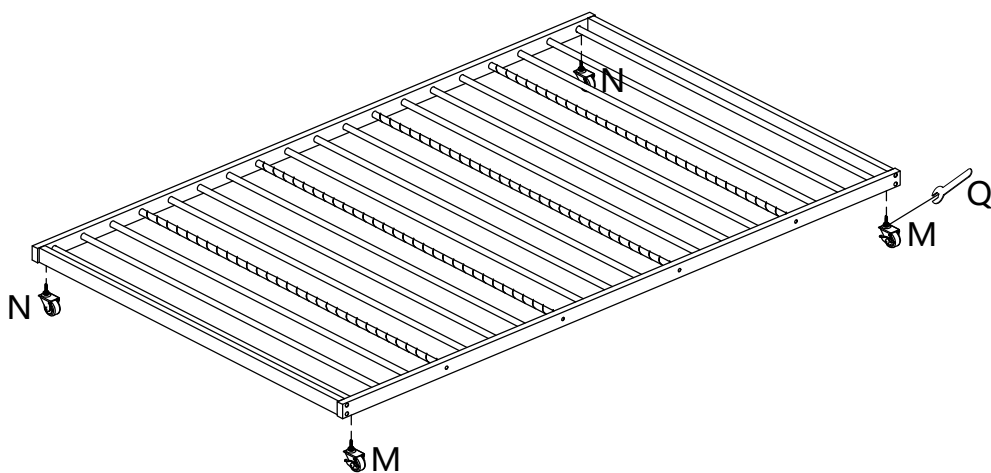

STEP 19:

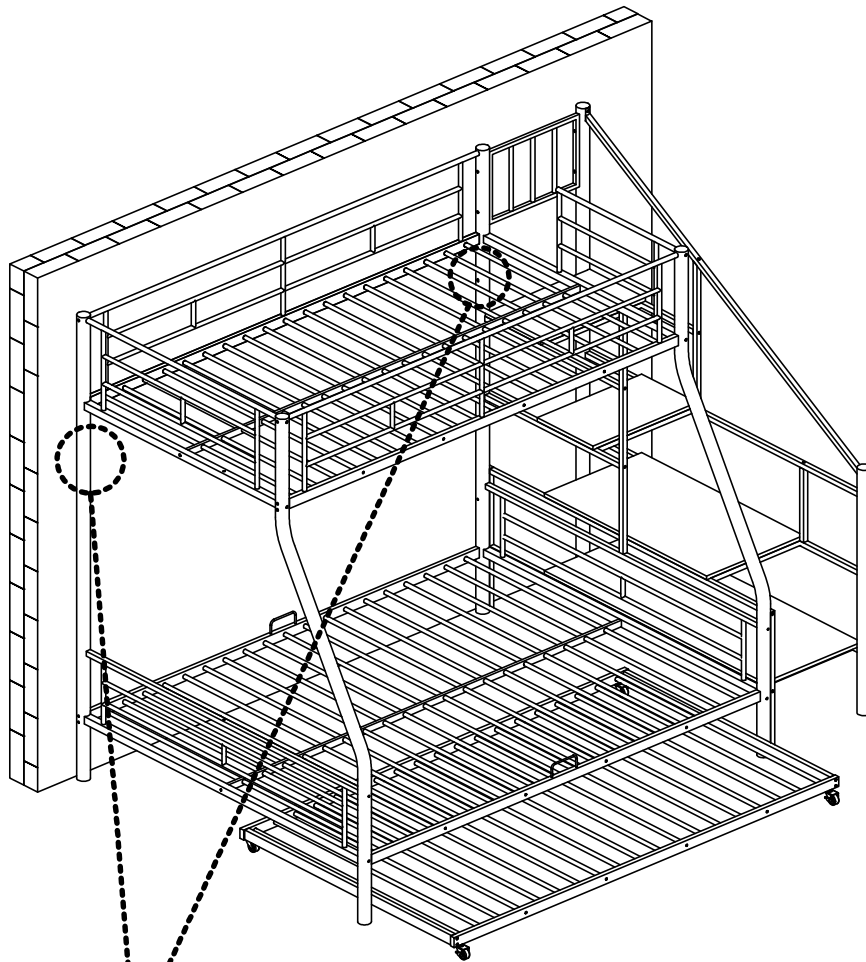

J	K
2PCS	2PCS
L	S
2PCS	2PCS

