

Assembly Instruction



Important reminder:

- △ Please sort and check all accessories before assembly.
- △ Please place the product on empty cardboard box or carpet to avoid scratches on it.
- △ Please use proper tools for assembly. Using an electric screwdriver can accelerate the assembly speed, but please do not overtighten the screws.
- △ Please follow the assembly steps and do not skip any of them.
- △ If possible, please find a partner to help you with assembly, which can accelerate assembly.
- △ Keep all small parts of this product away from children. They may cause serious injury.
- △ We hope you can retighten the screws 2 weeks after assembly, and check the tightening procedure of the screws every 3 months.

If you meet any difficulty, our friendly customer team are always ready to help you.

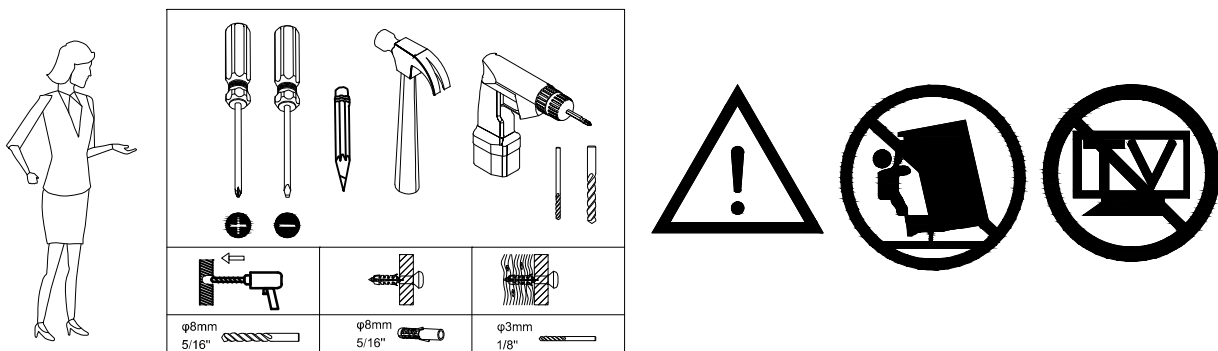

Warning:Overturning the product can cause serious crushing injuries. We have a wall connection device attached, please use it to hold the furniture following assembly instructions. Do not change the structure of this product in way. Our products have been tested and meet any all sales specific security measures. We won't be responsible for any modifications, which may cause significant security risks.

Static charge may cause dust on foam—clean with a dry or damp cloth. Small foam strands may be present—handle gently and dispose of properly. Do not burn or incinerate. Check local recycling guidelines.

If you encounter any problems during installation, Please contact our customer service.

Explosion Diagram

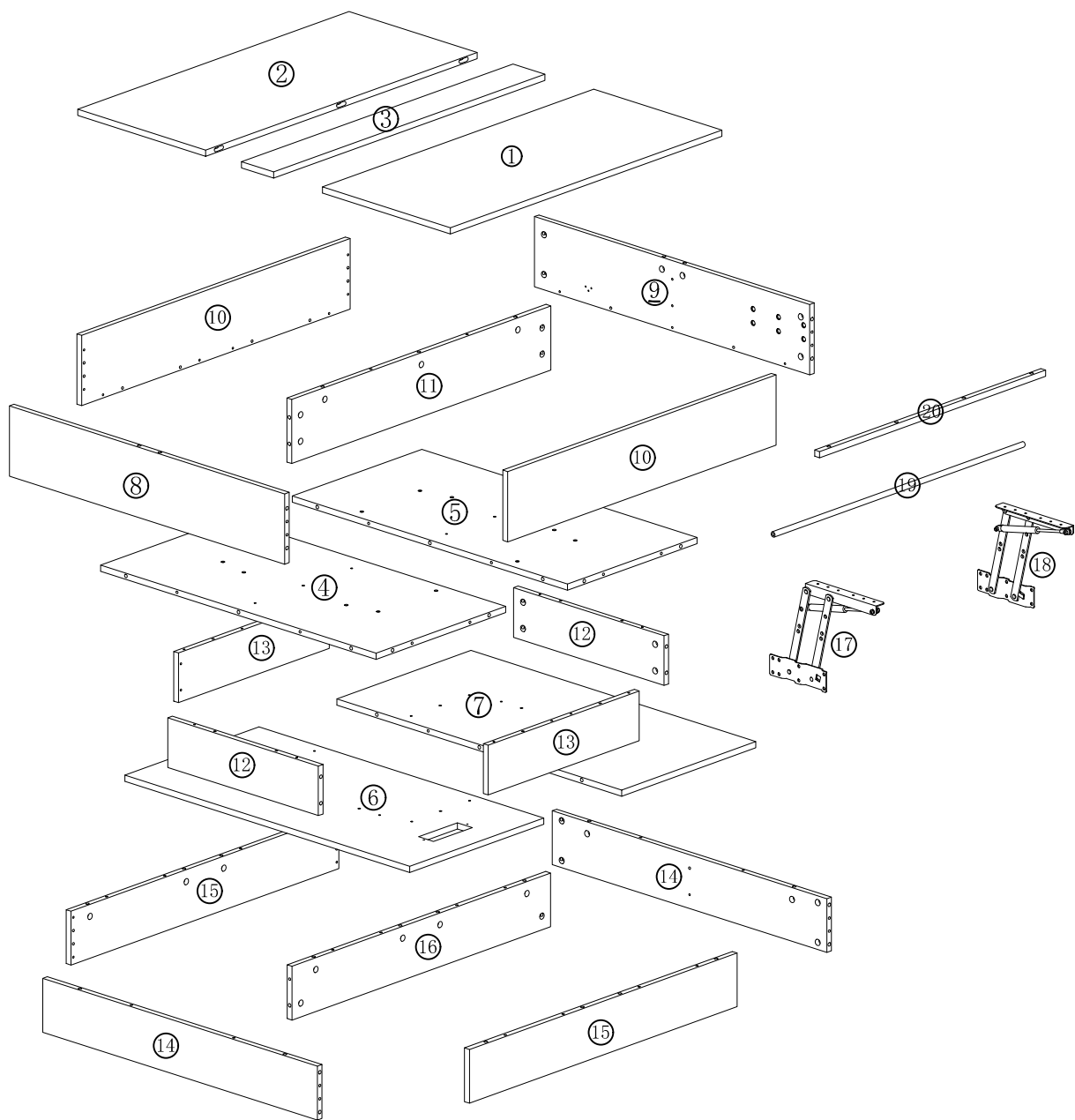

If you encounter any problems during installation, Please contact our customer service.

Parts and Operation Elements

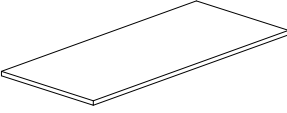
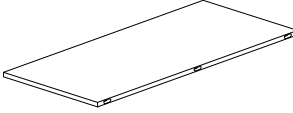
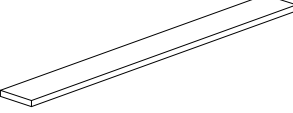
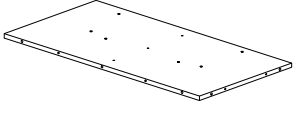
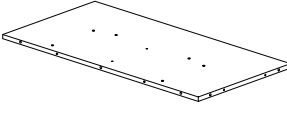
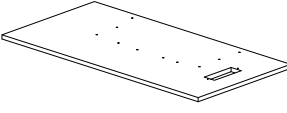
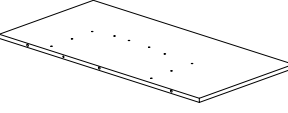
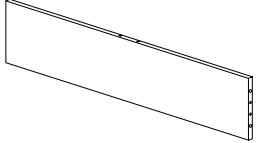
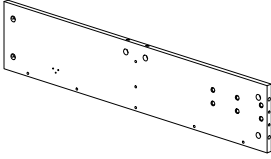
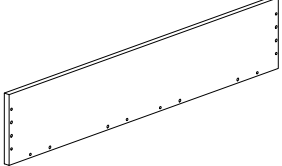
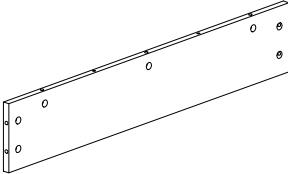
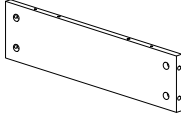
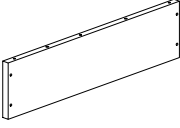
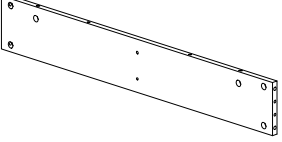
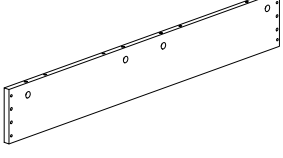
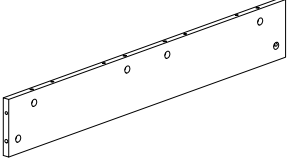
			
① 1Pc	② 1Pc	③ 1Pc	④ 1Pc
			
⑤ 1Pc	⑥ 1Pc	⑦ 1Pc	⑧ 1Pc
			
⑨ 1Pc	⑩ 2Pcs	⑪ 1Pc	⑫ 2Pcs
			
⑬ 2Pcs	⑭ 2Pcs	⑮ 2Pcs	⑯ 1Pc

If you encounter any problems during installation, Please contact our customer service.

Parts and Operation Elements

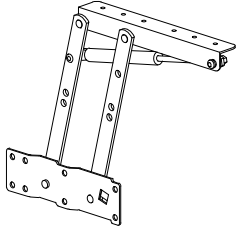

⑰

1Pc

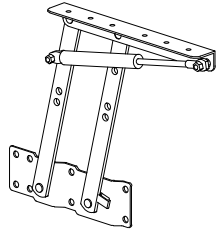

⑱

1Pc

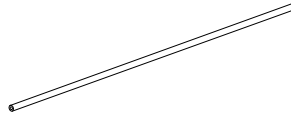

⑲

1Pc

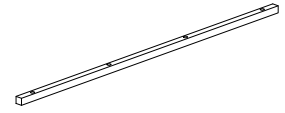











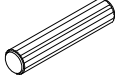
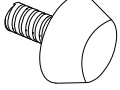
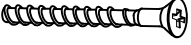

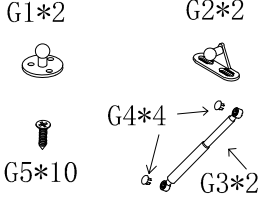

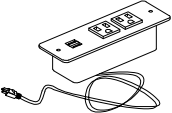
⑳

1Pc

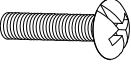
If you encounter any problems during installation, Please contact our customer service.

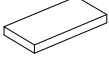
HardWare

 $\phi 5 \times 40$ Cam Bolt		 $\phi 15 \times 9.5$ Cam Lock		 $\phi 6 \times 30$		 $M6 \times 15mm$	
A	73PCS +4PCS	B	73PCS +4PCS	C	70PCS +4PCS	D	4PCS
 $M5 \times 40$		 $\phi 3.5 \times 14mm$		 $G1 \times 2$ $G2 \times 2$ $G5 \times 10$ $G4 \times 4$ $G3 \times 2$			
E	28PCS +2PCS	F	10PCS +2PCS	G	2SETS	H	8PCS +1PC
				 $\phi 3 \times 35$			
I	1PCS	J	1SET	K	12PCS +2PCS	L	3PCS
 $M6 \times 23$		 $M5 \times 10$					
M	6PCS	N	12PCS +1PC	O	3PCS	P	23PCS +2PCS

 Tips: The number after "+" represents the spare hardware.

If you encounter any problems during installation, Please contact our customer service.

1

X2

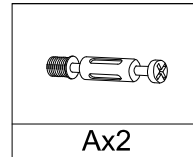
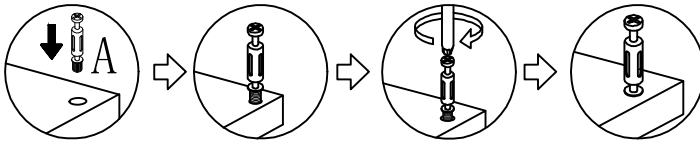
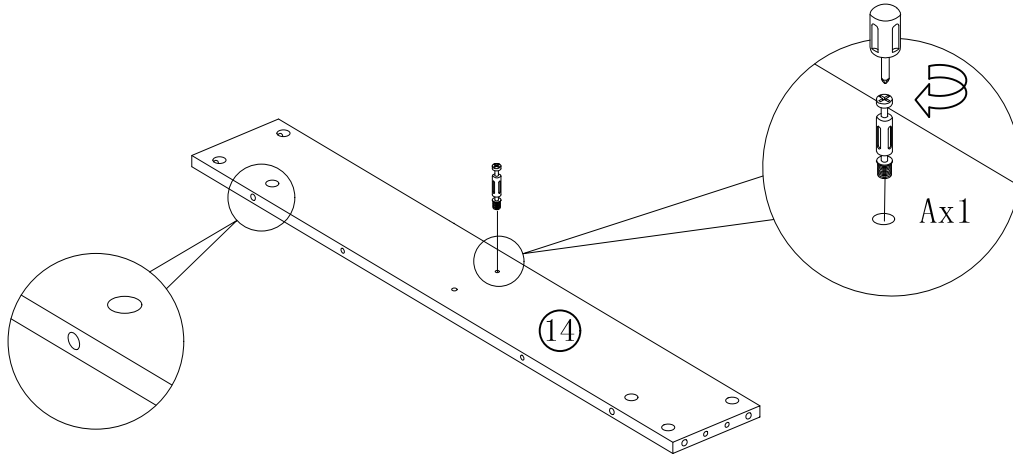

Ax2

2

The side with holes faces upwards.

The side with holes faces upwards.

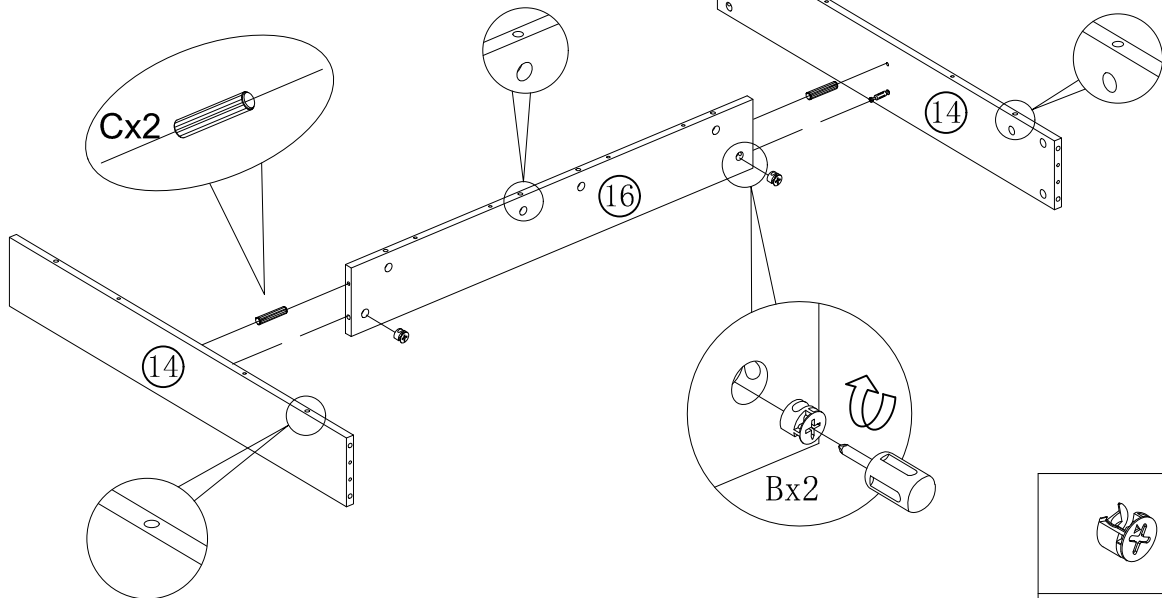

The side with holes faces upwards.

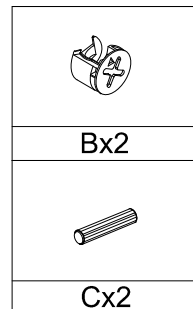

Bx2

Cx2

If you encounter any problems during installation, Please contact our customer service.

3

X2

When the ground is uneven or the product shakes, the D component can be used to adjust the flatness

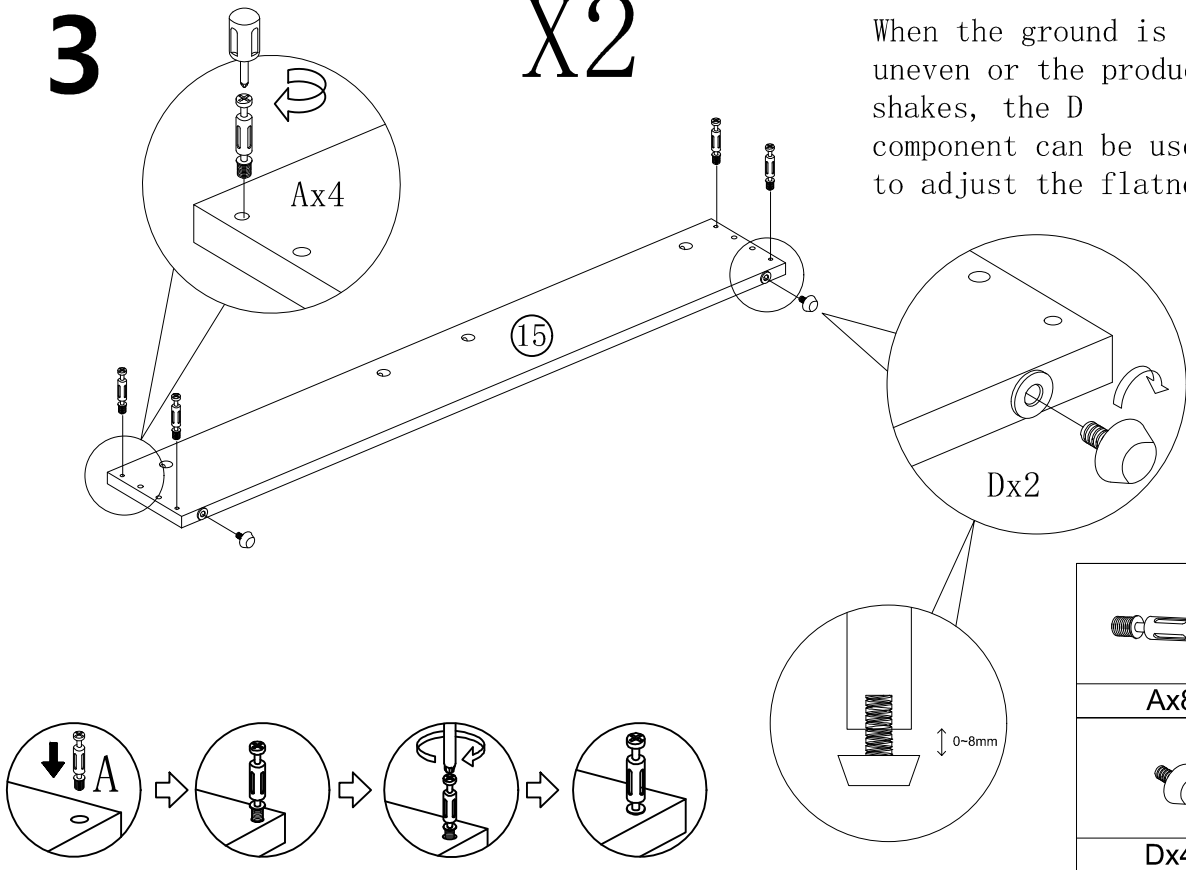

4

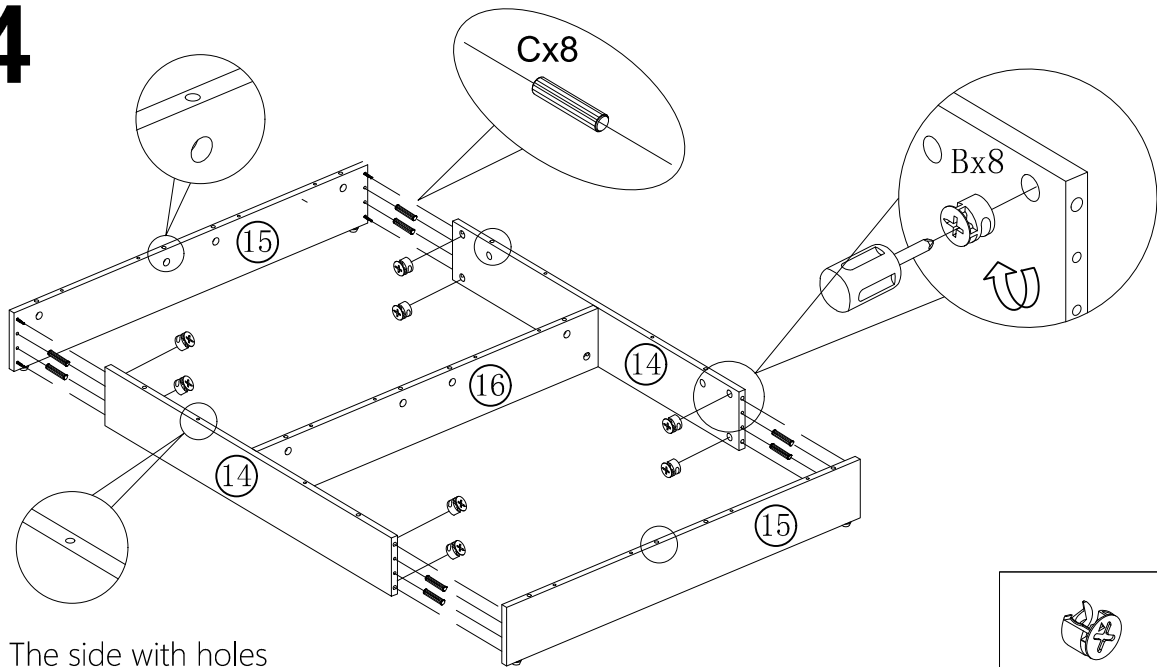

The side with holes faces upwards.

If you encounter any problems during installation, Please contact our customer service.

5



Double installation

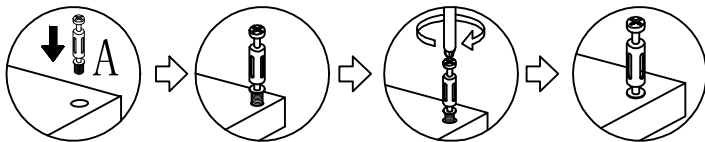
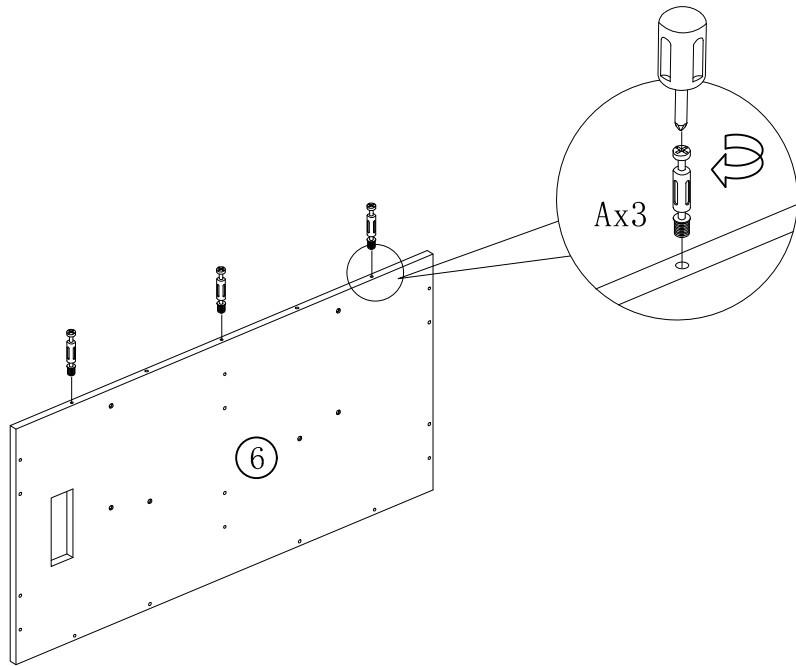

Ax3

6

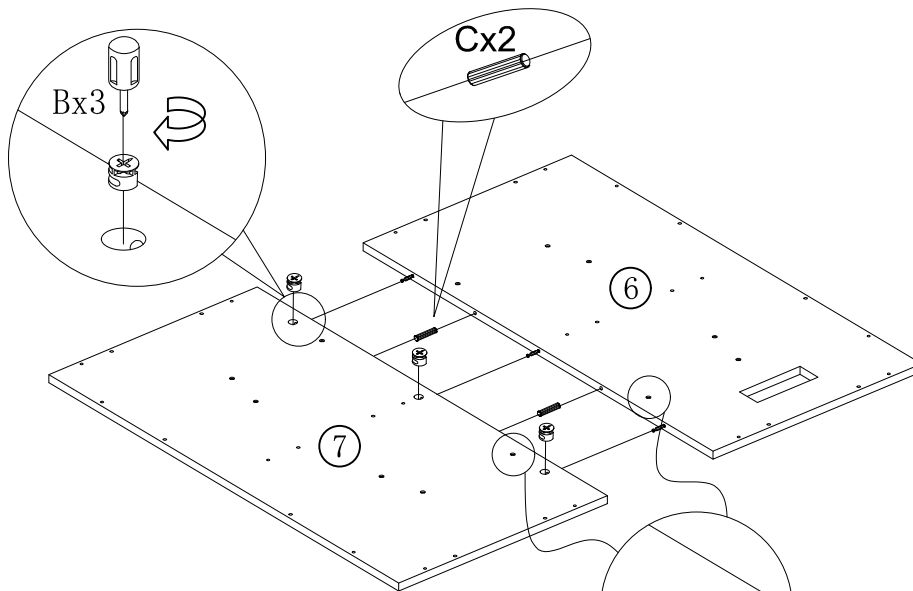

Sink your head
on one side



Bx3



Cx2

If you encounter any problems during installation, Please contact our customer service.

7

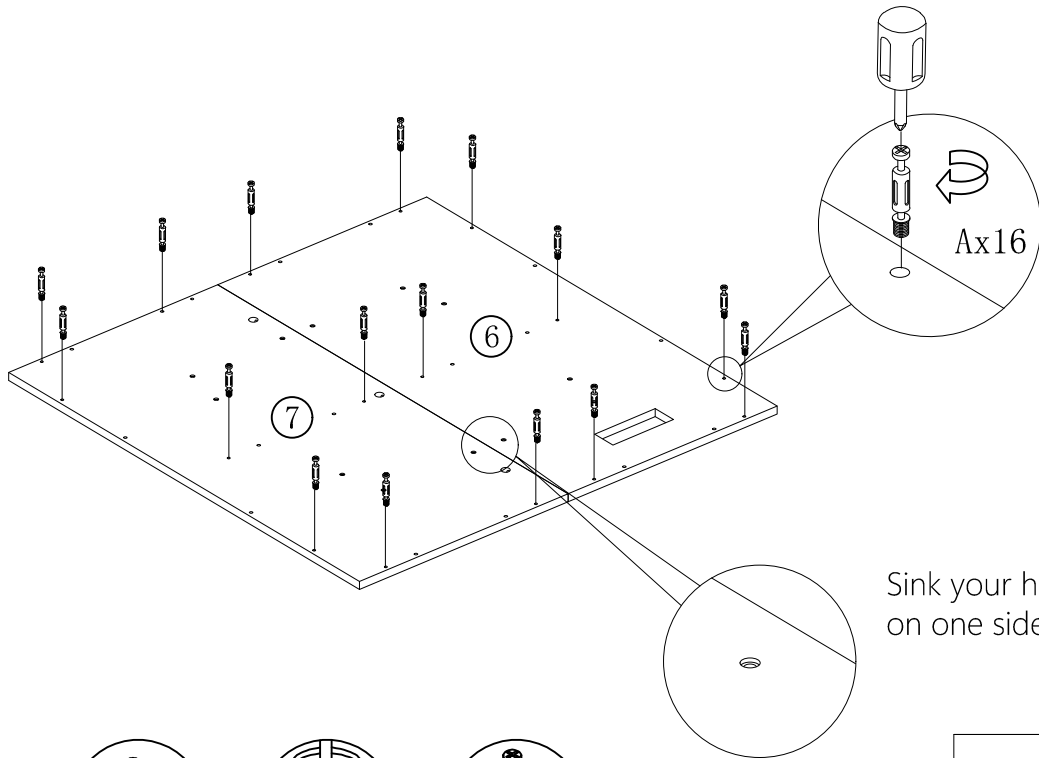

Sink your head on one side

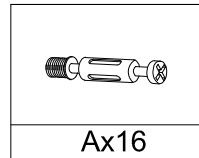
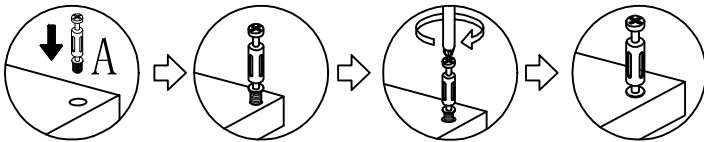

8

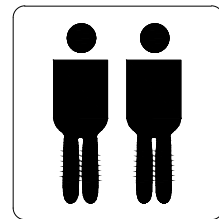
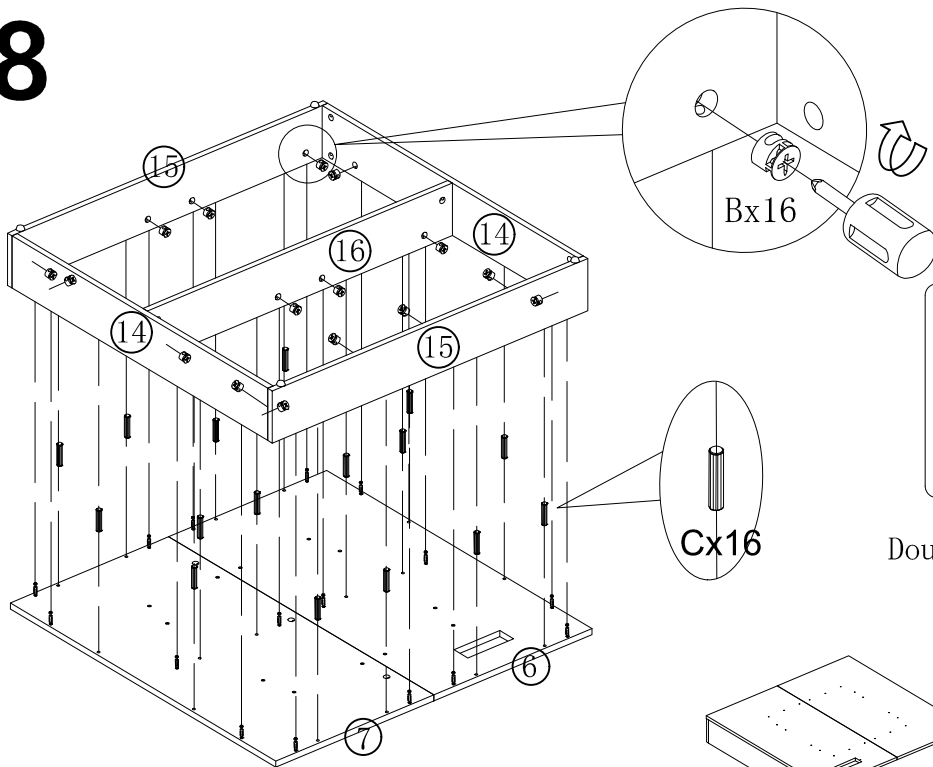

Double installation

Connect with C first, then lock B.

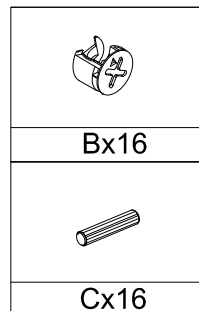

If you encounter any problems during installation, Please contact our customer service.

9

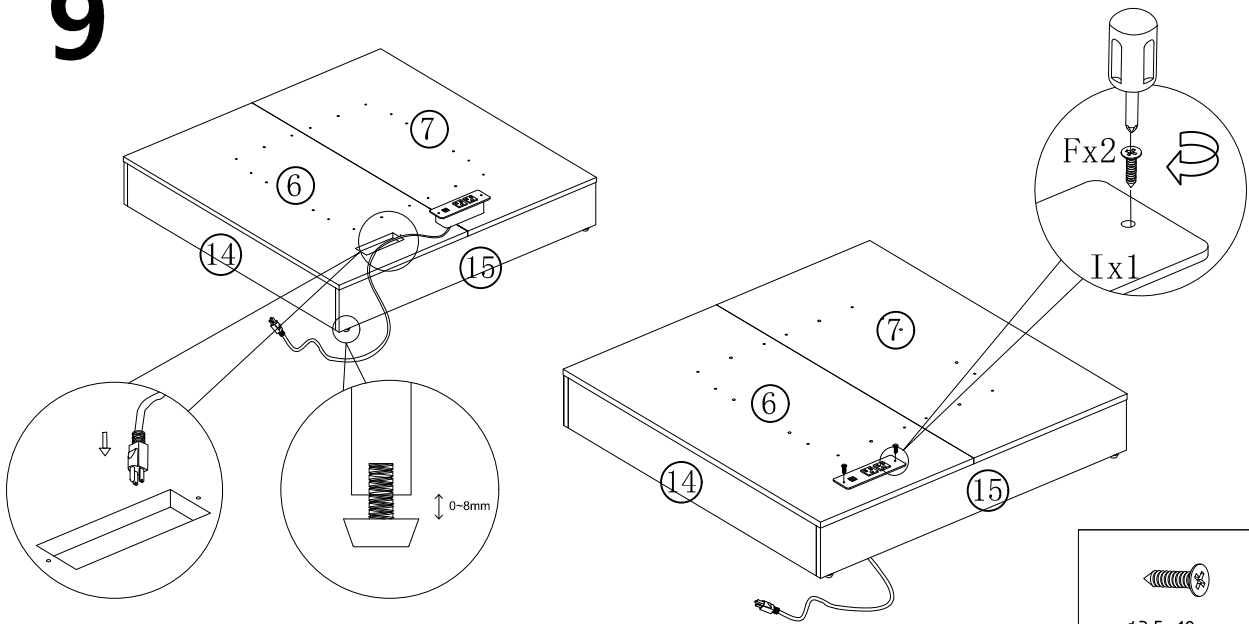

Insert the power strip through the hole, pay attention to adjusting the height of D so that the wire can pass through from below. When the ground is uneven, you can also adjust D to keep the cabinet balanced.

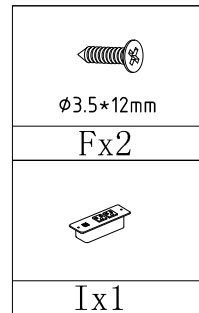

10

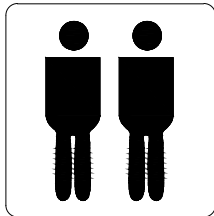

Double installation

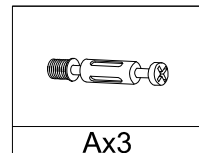
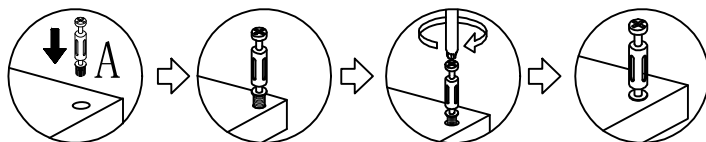
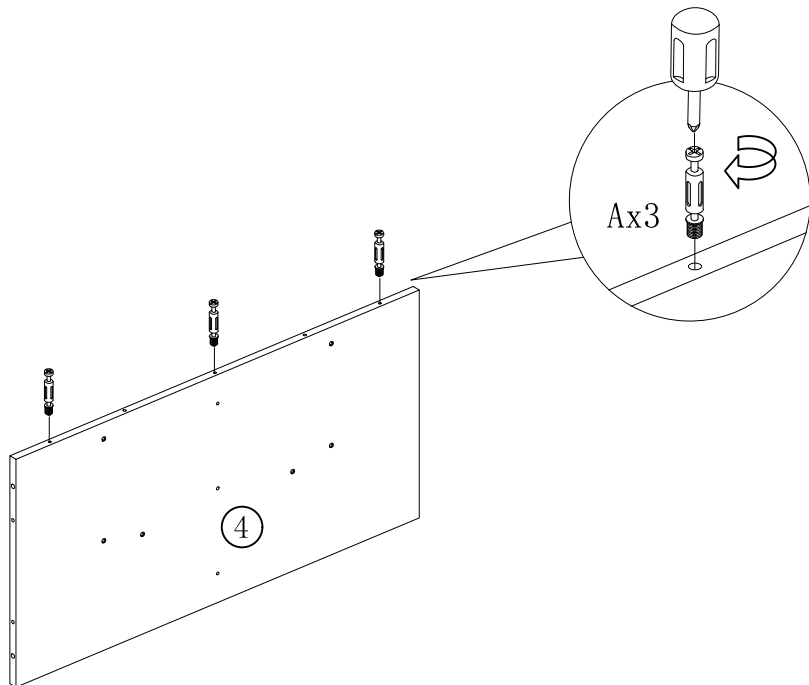

If you encounter any problems during installation, please contact our customer service.

11

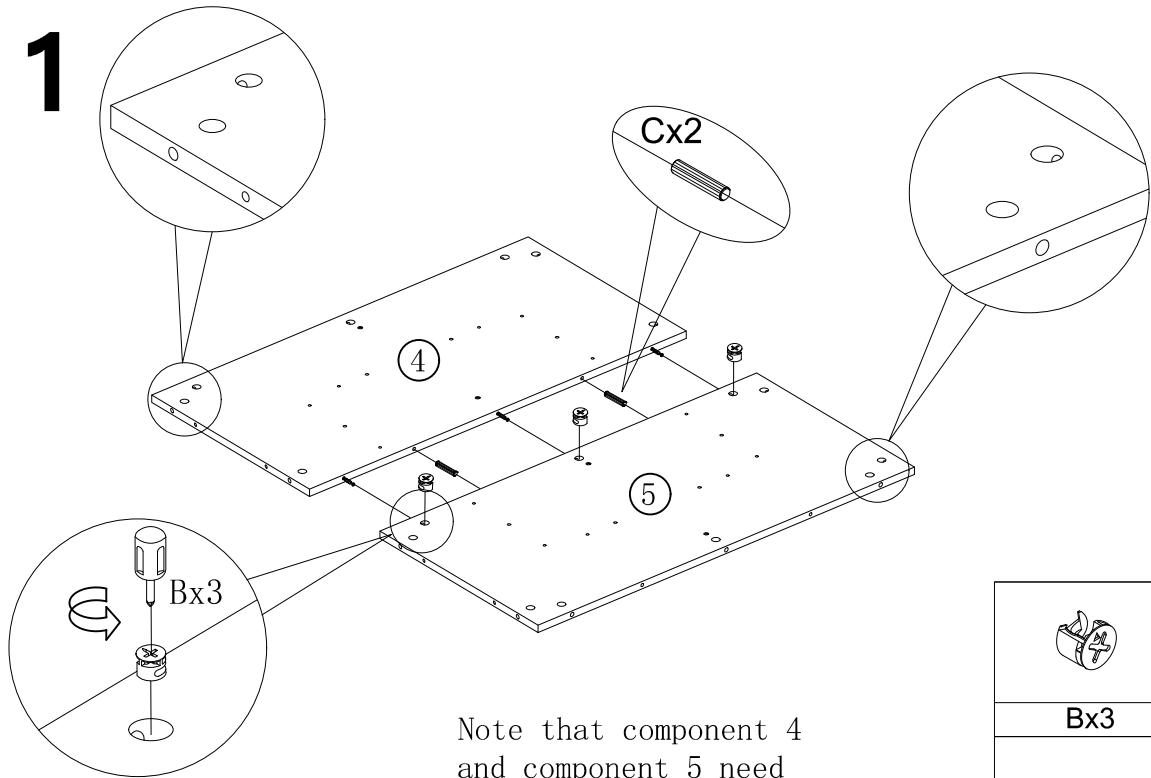

Note that component 4 and component 5 need to be on the same side.

Bx3
Cx2

12

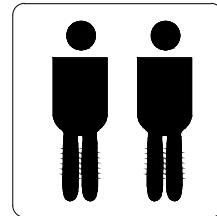
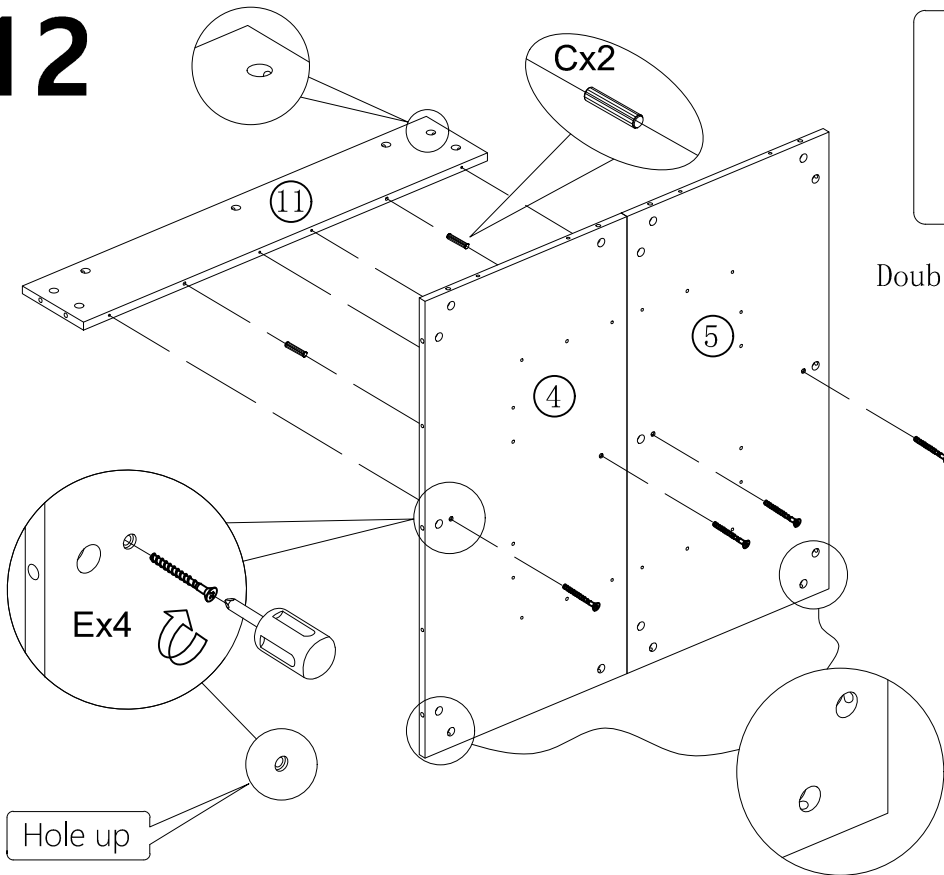

Double installation

M6*30
Cx2
M5*4.0
Ex4

If you encounter any problems during installation, Please contact our customer service.

13

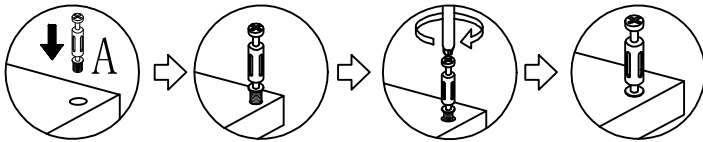
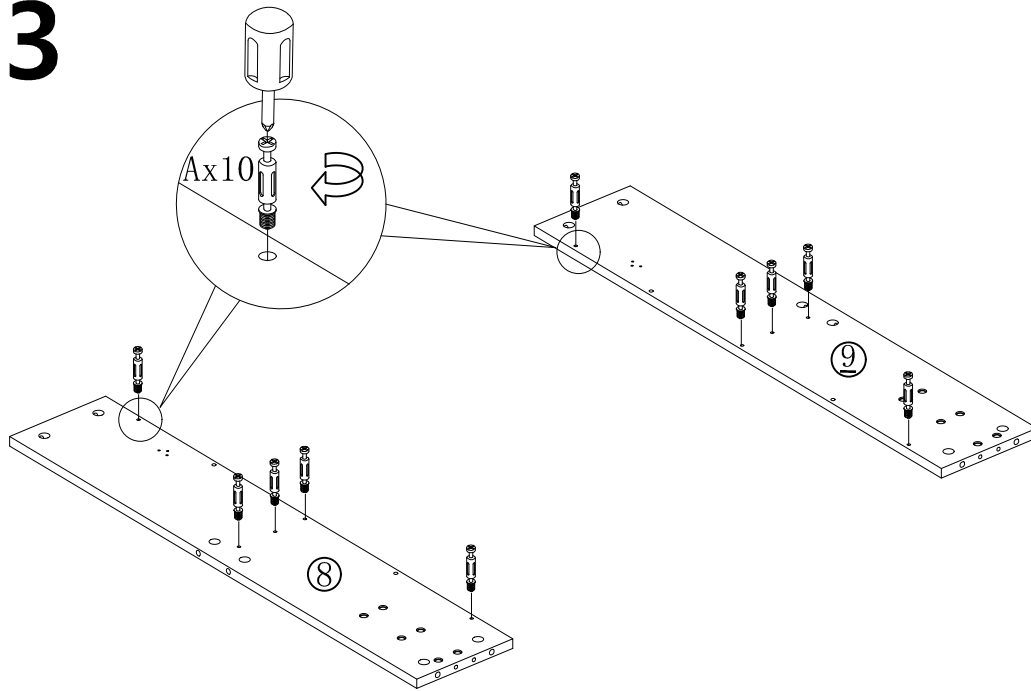

Ax10

14

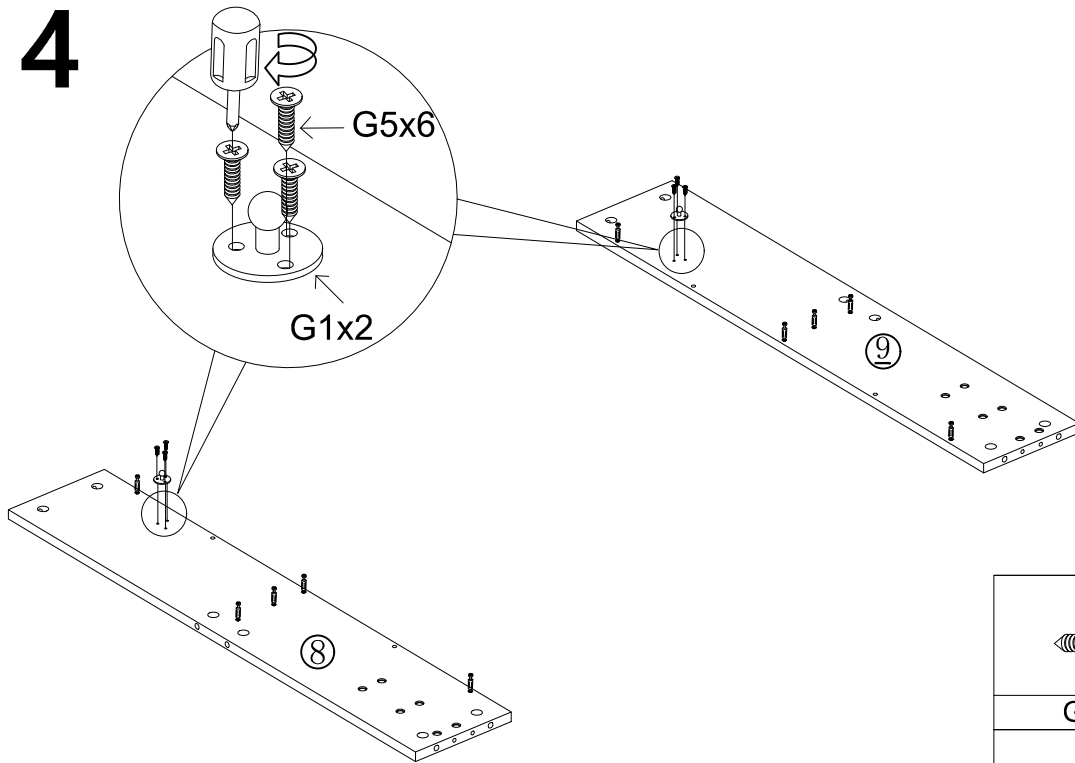

G5x6



G1x2

If you encounter any problems during installation, Please contact our customer service.

15

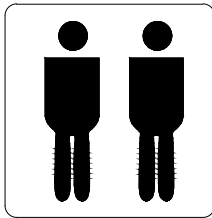
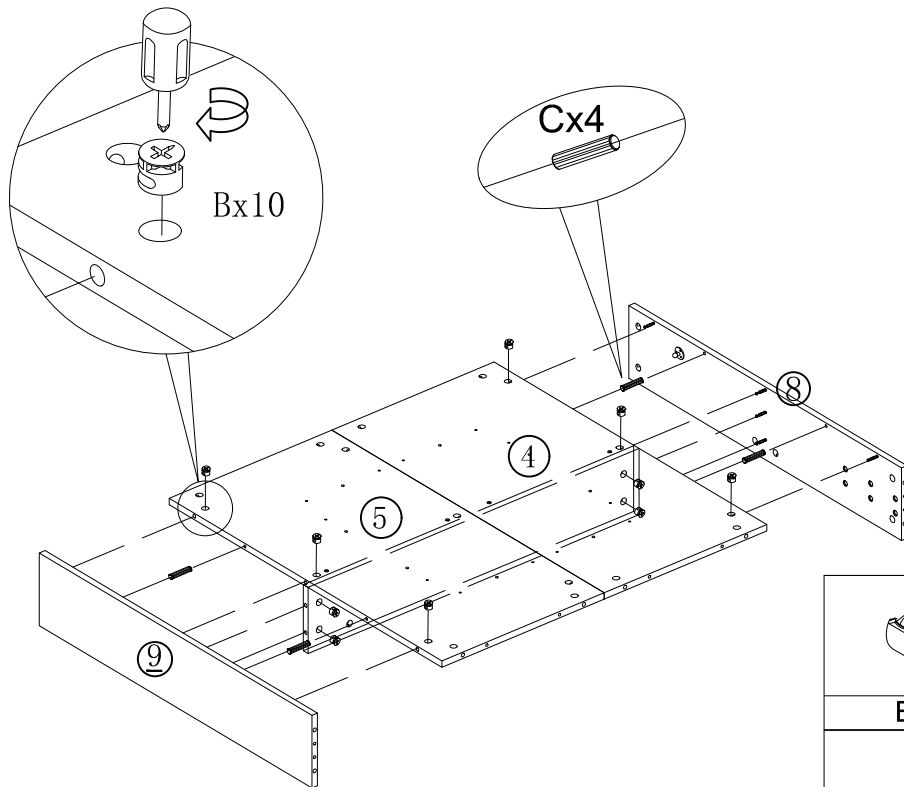

Double installation

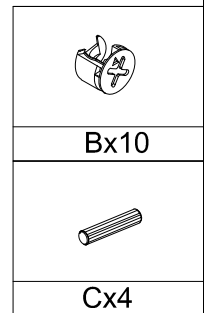

16

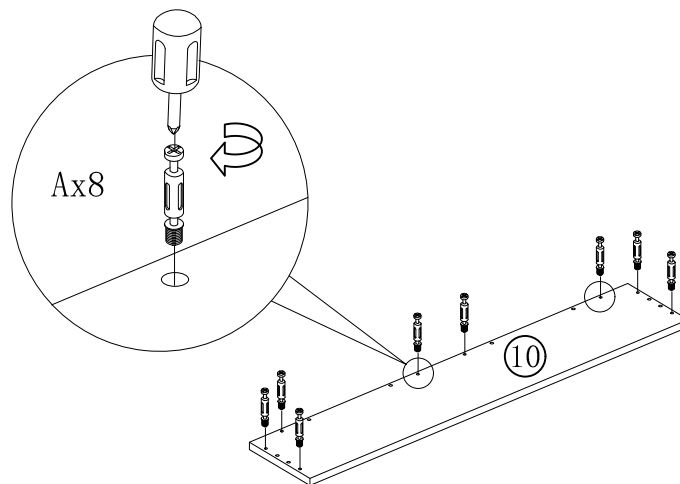

X2

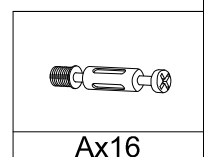
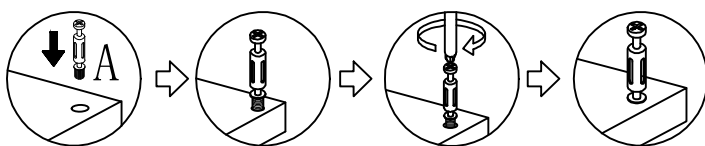

If you encounter any problems during installation, Please contact our customer service.

17

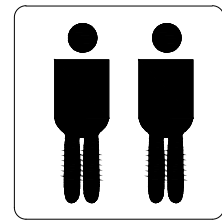
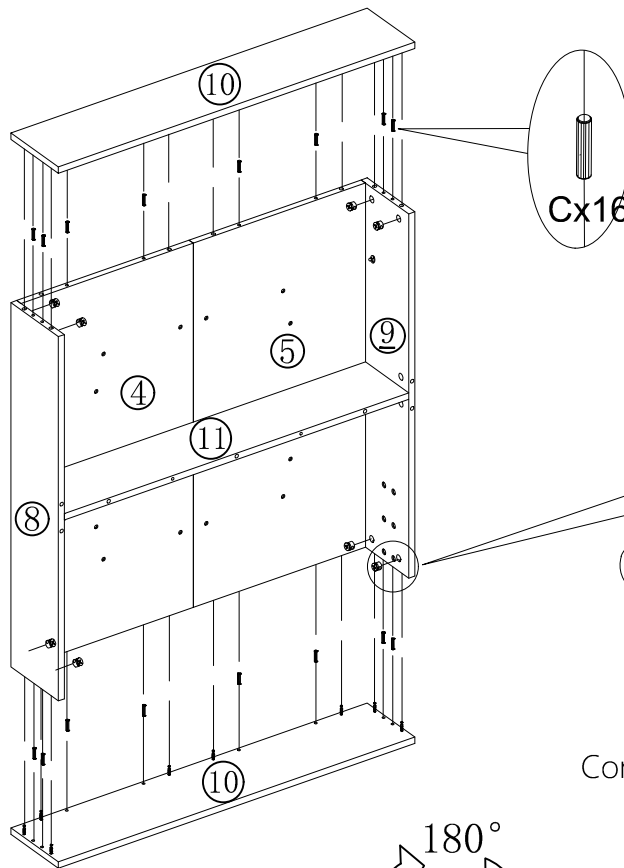

Double installation

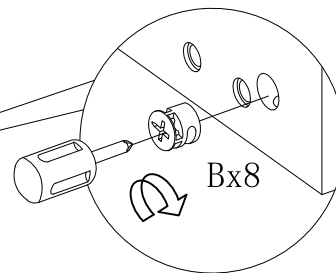

Connect with C first, then lock B.

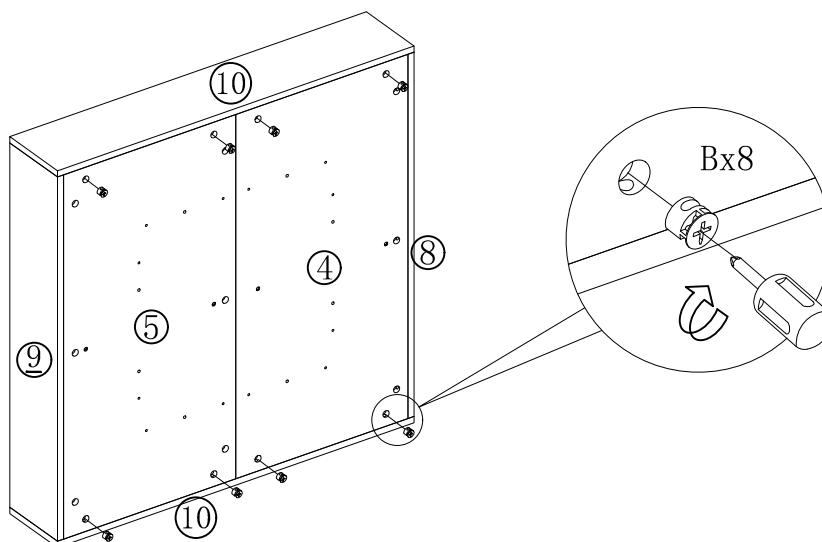
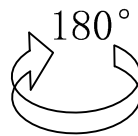

Bx16
Cx16

If you encounter any problems during installation, Please contact our customer service.



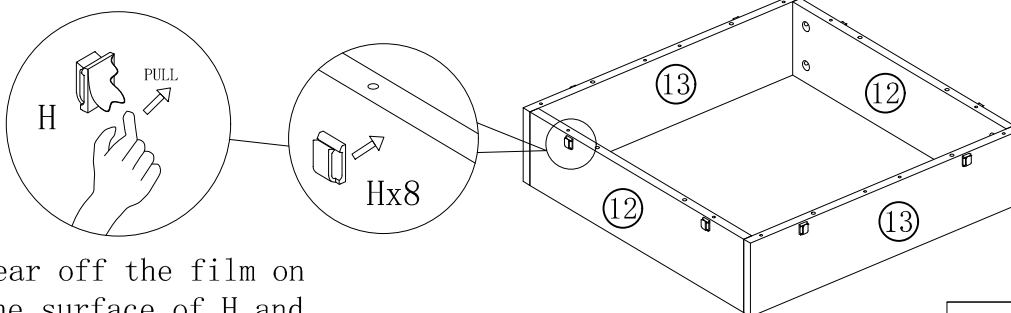
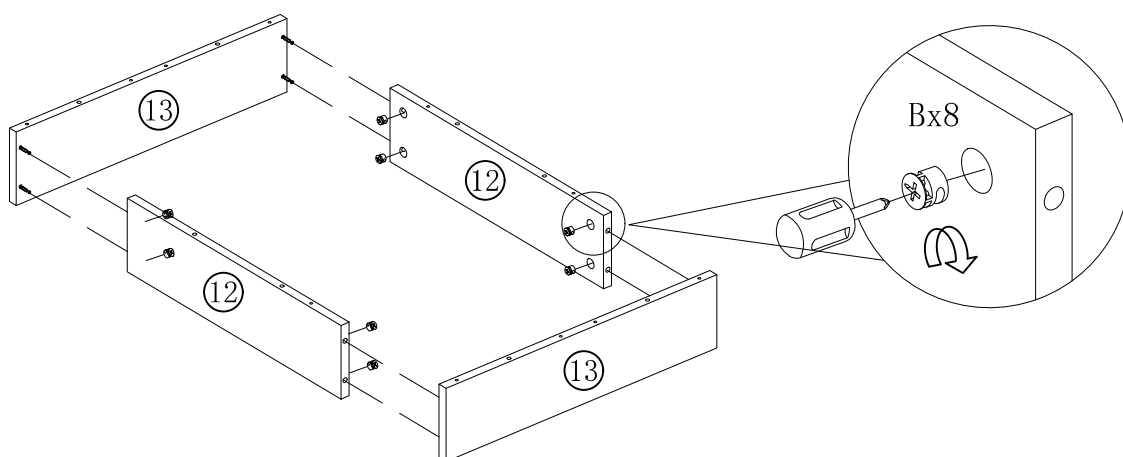
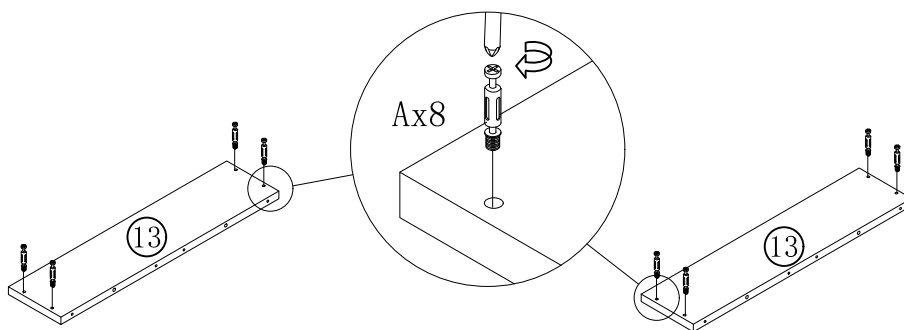

18

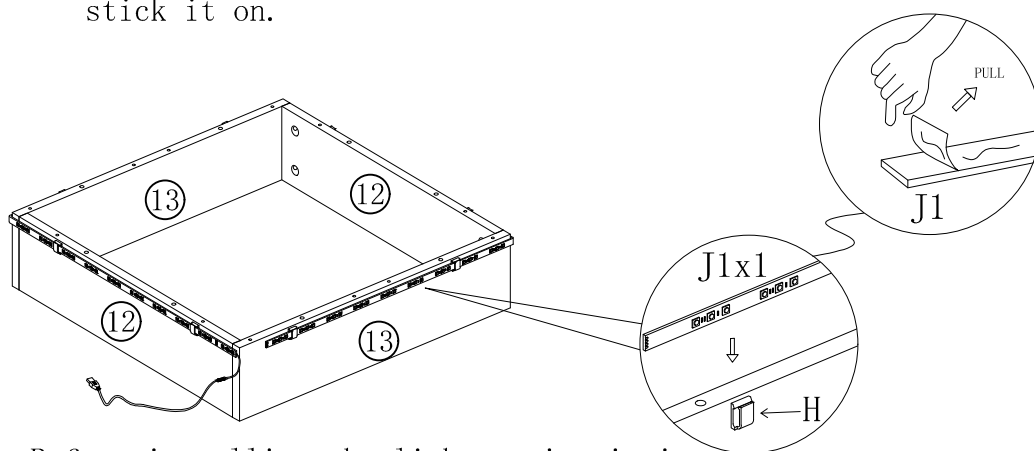

Tear off the film on the surface of H and stick it on.



Before installing the light strip, it is necessary to tear off the film on the light strip to make it more secure.

	Ax8
	Bx8
	Hx8
	Jx1

If you encounter any problems during installation, Please contact our customer service.

19

Pay attention to the placement of the H component for ease of use.

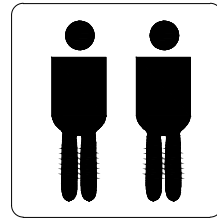

Double installation

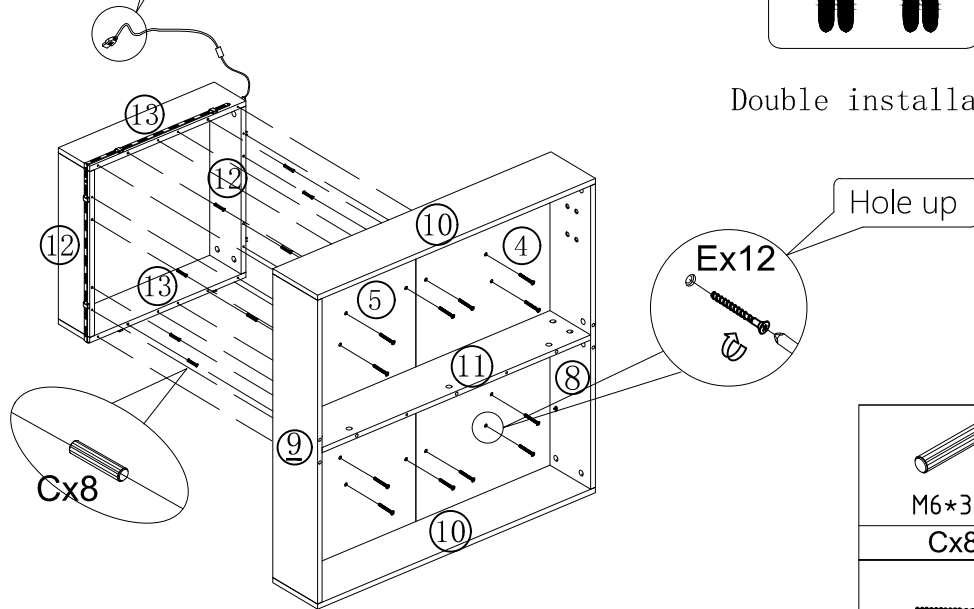

Hole up

Ex12

Cx8



M6*30

Cx8



M5*4.0

Ex12

This step requires two people to install together. First, align component C with the hole position, and then lock component E.

20

Plug in board hole

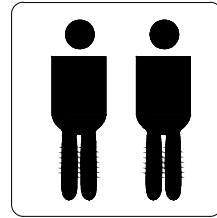

Double installation

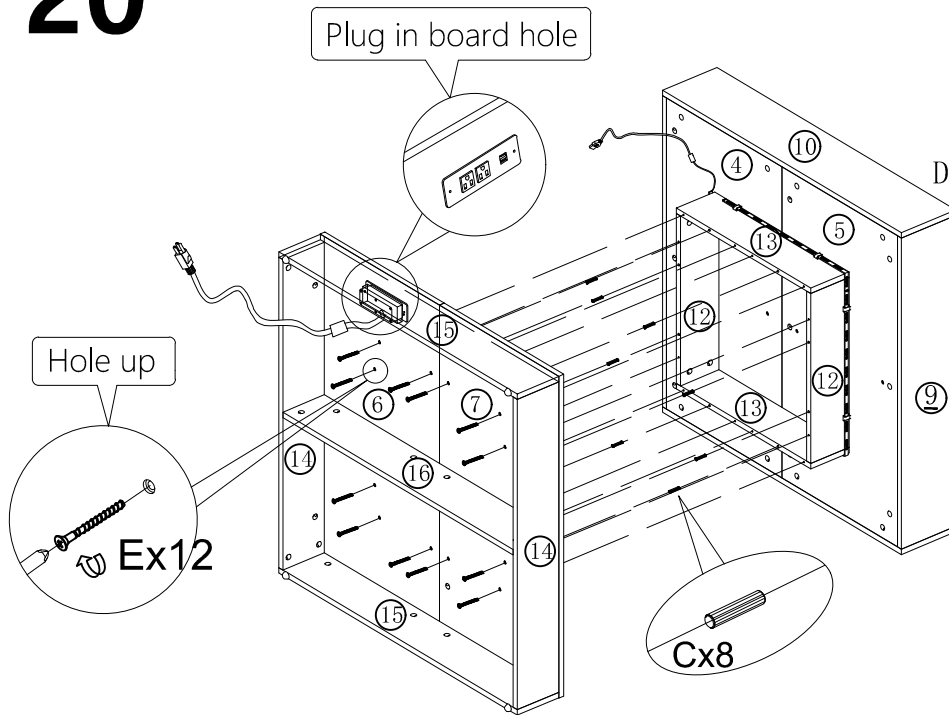

Hole up

Ex12

Cx8



M6*30

Cx8



M5*4.0

Ex12

This step requires two people to install together. First, align component C with the hole position, and then lock component E.

If you encounter any problems during installation, Please contact our customer service.

21

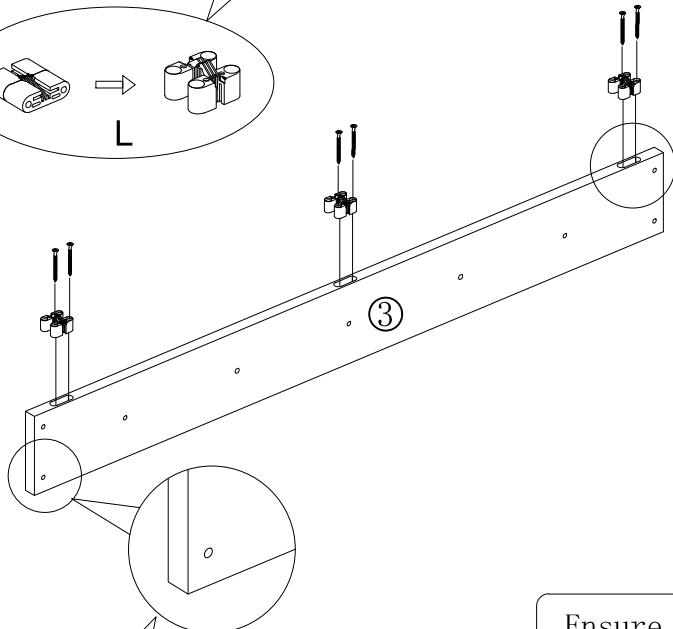
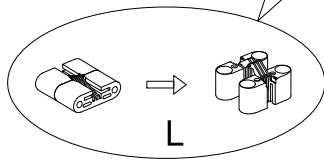

Fold the L accessory into a folded shape and then insert it into the hole

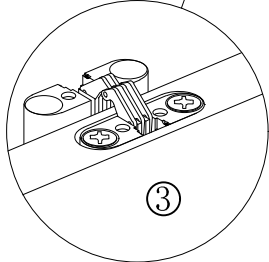
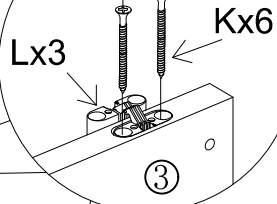

One side with holes

Ensure that K lock is level or slightly lower



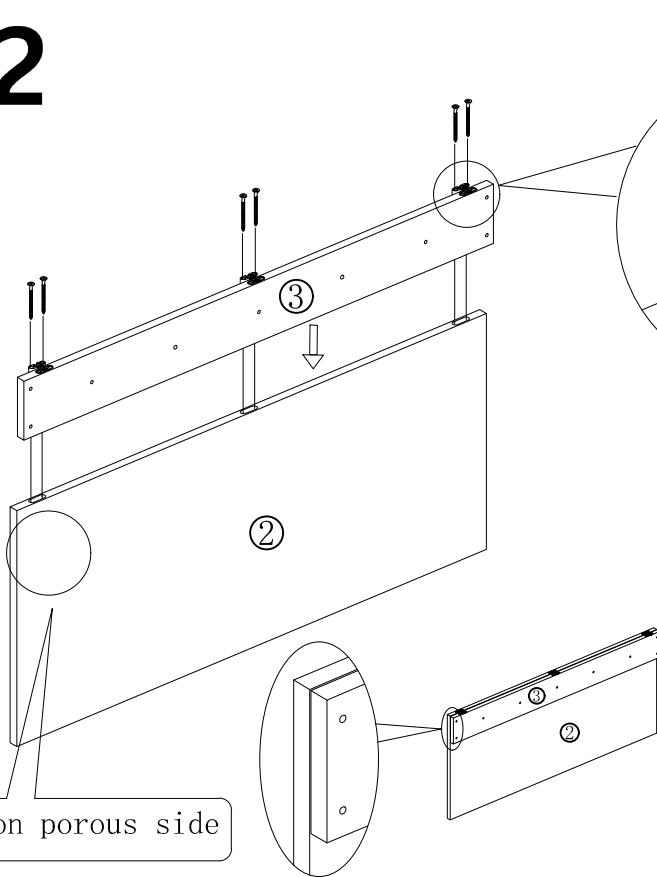

$\phi 3 \times 35$
Kx6

Lx3

22

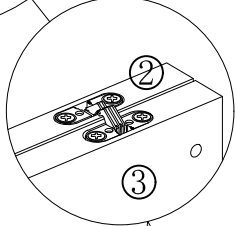
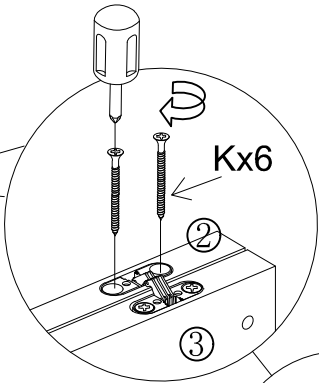

The non porous side

Ensure that K lock is level or slightly lower





M3*35
Kx6

If you encounter any problems during installation, Please contact our customer service.

23

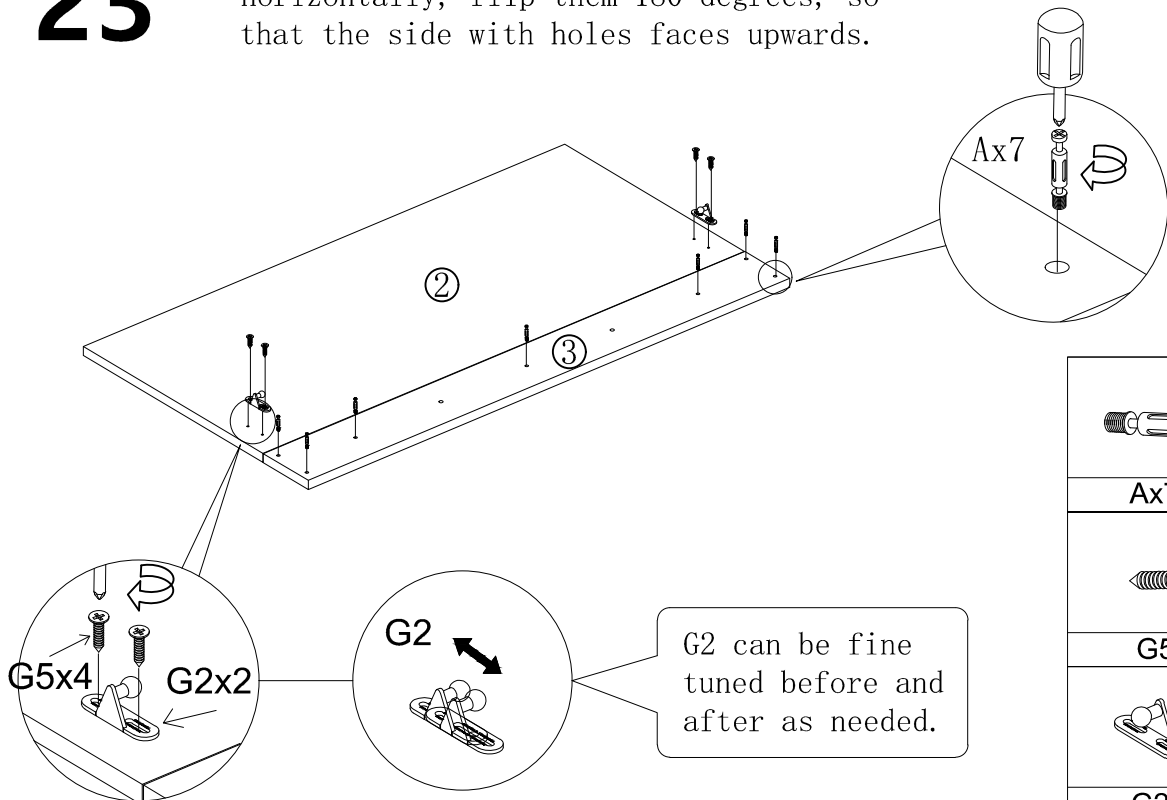
Unfold the 2nd and 3rd components horizontally, flip them 180 degrees, so that the side with holes faces upwards.



24

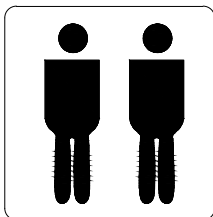
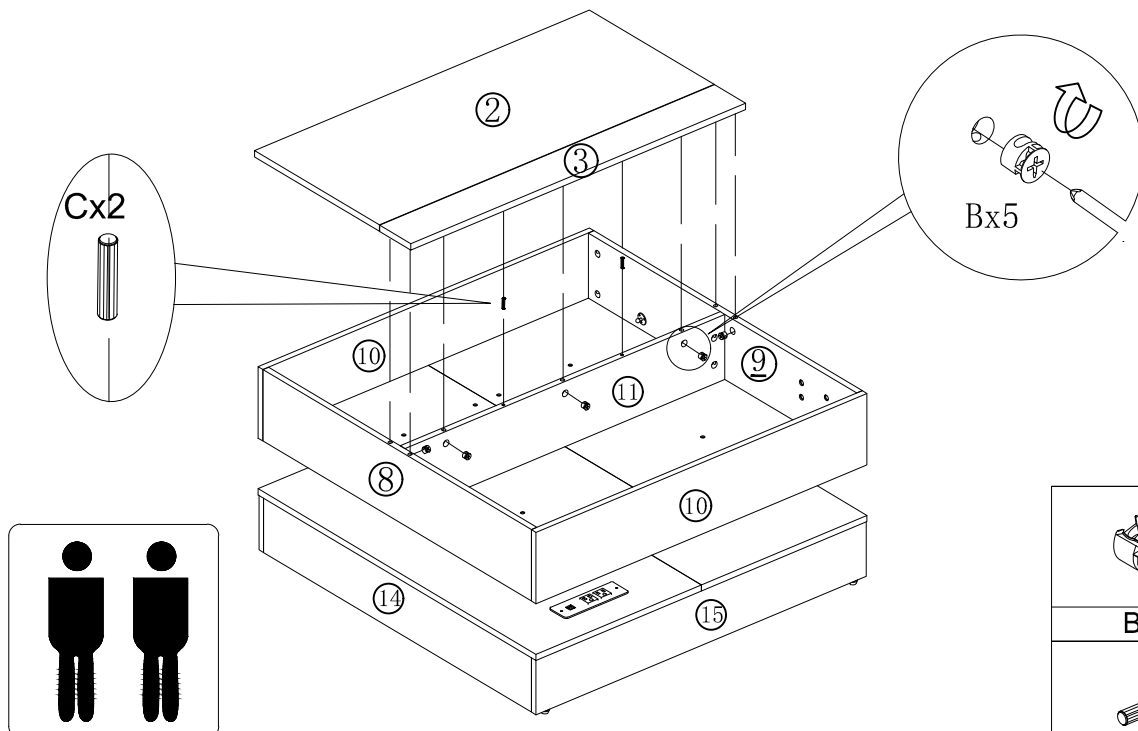

Double installation

If you encounter any problems during installation, Please contact our customer service.

25

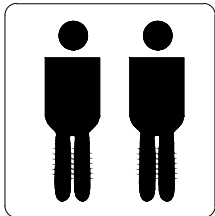
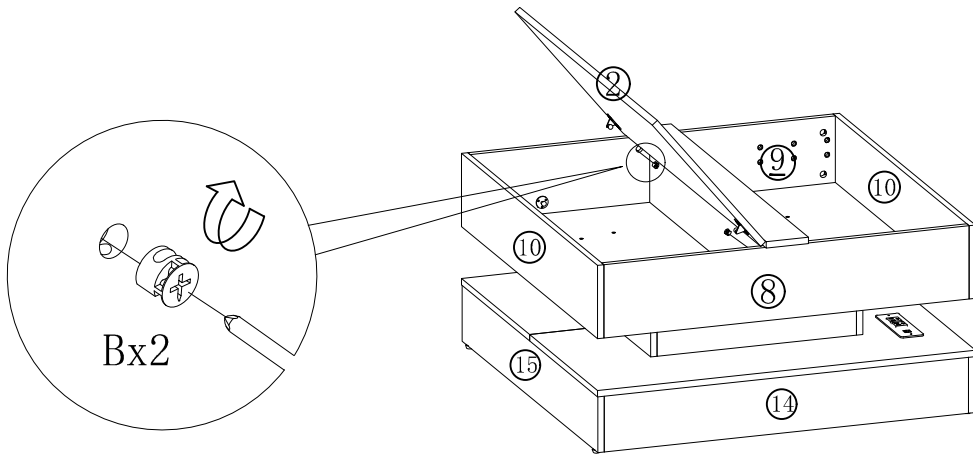

Double installation

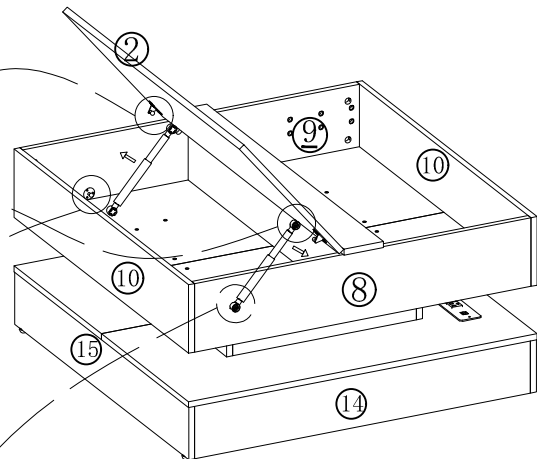
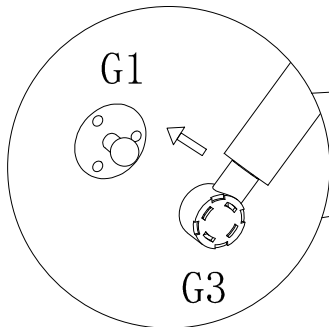
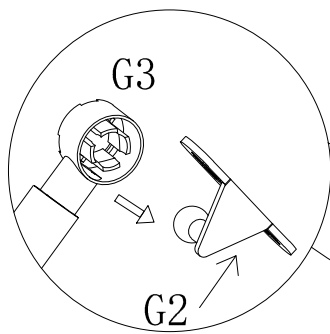
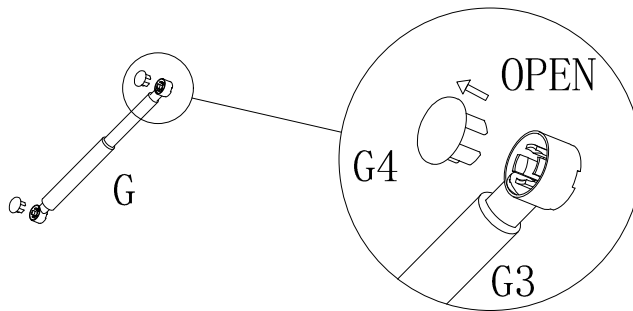

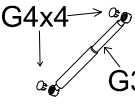

Bx2

G4x4 G3x2
G3x2/G4x4

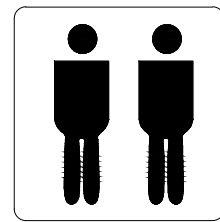
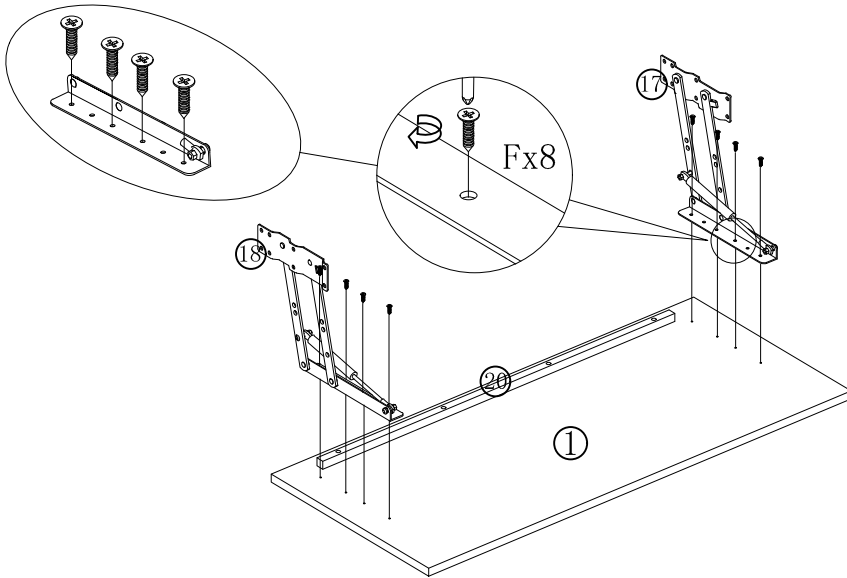
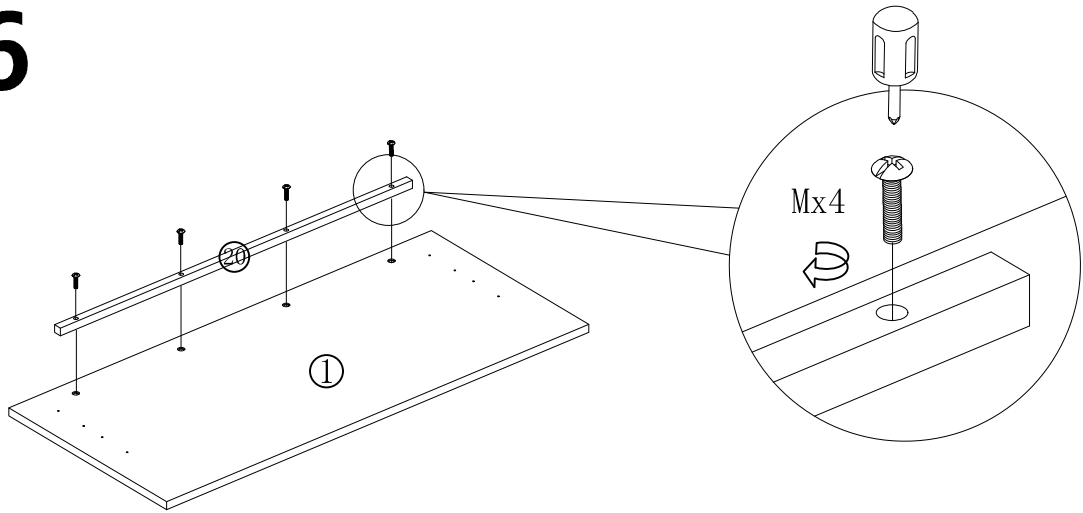

If you encounter any problems during installation, Please contact our customer service.

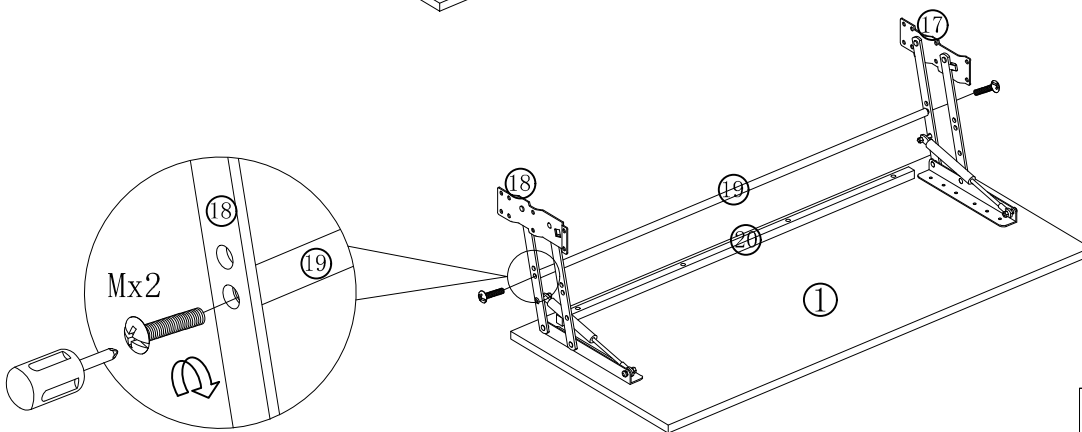
26



Double installation





M6*23
Mx5

φ3.5*14
Fx8

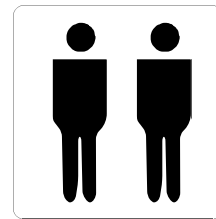

If you encounter any problems during installation, Please contact our customer service.

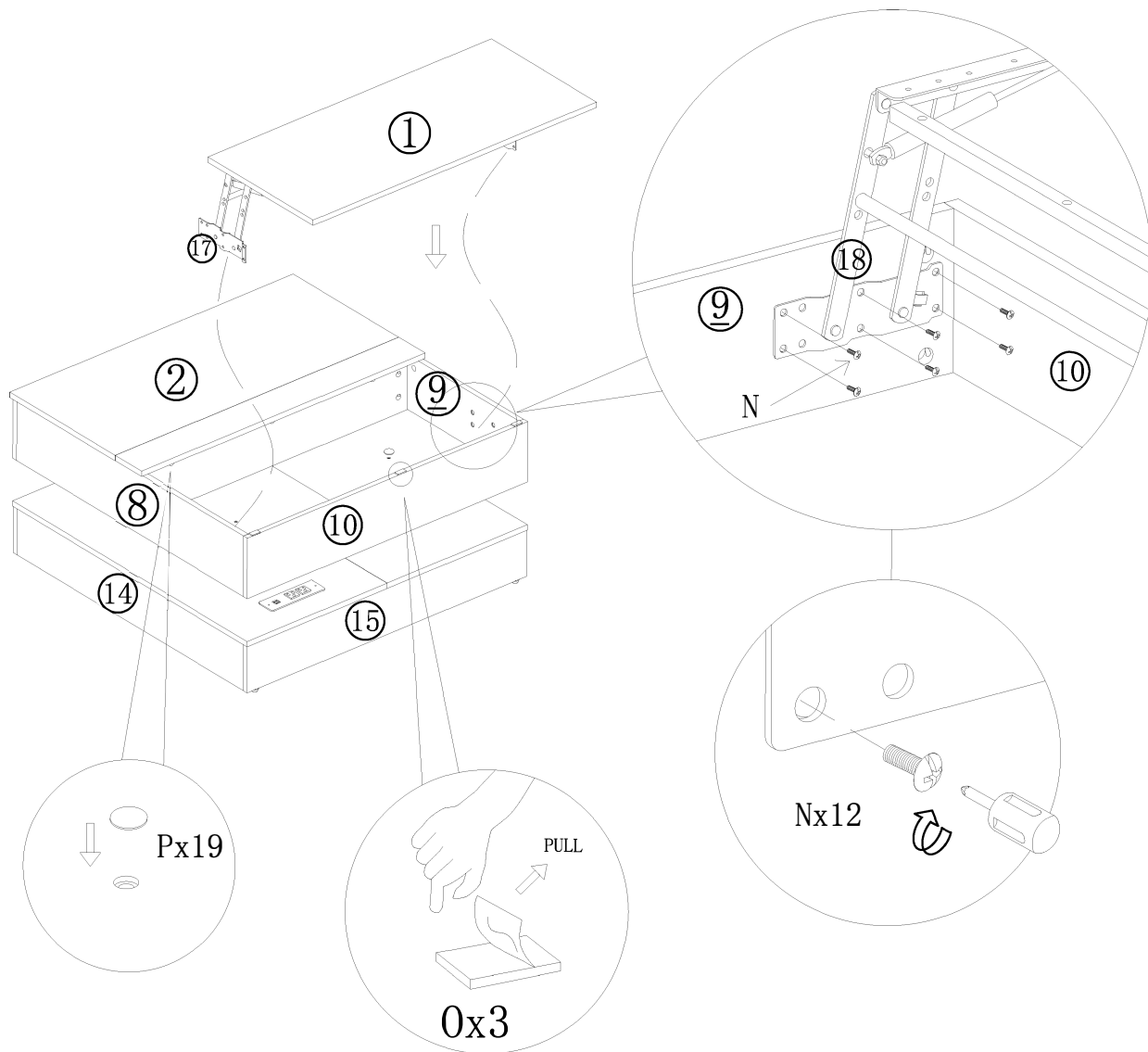
27



Double installation



		
Px23	Ox3	M5*10 Nx12

If you encounter any problems during installation, please contact our customer service.