

ASSEMBLING & INSTALLATION INSTRUCTIONS PRODUCT

For Ceiling Mount Fixtures

WARNING! SHUT POWER OFF AT FUSE OR CIRCUIT BREAKER .

MOUNTING THE FIXTURE

1. Shut off the power at the fuse box or circuit breaker box. Remove the old fixture from ceiling, including the mounting plate.
2. Carefully unpack your new fixture and lay out all the parts on a clear area. Take care not to lose any small parts necessary for installation.
3. Thread the two mounting screws about 1/4" into the pre-drilled holes in the mounting plate spaced the same distance apart as the holes in the pan (A).
4. Attach the mounting plate to the Junction Box using the two screws from the Junction Box. The side of the mounting plate marked "GND" must face out. **The junction box is not include.**
5. Hold the pan (A) towards the mounting plate and connect the electrical wires as follows (See Fig.2). Connect the black wire from the fixture to the black house (hot) wire; connect the white wire from the fixture to the white house (neutral) wire. Make sure all wire nuts are secured. You may wrap the connections with electrical tape. If your Junction box has a ground wire (green or bare copper) connects fixture's ground wire to it. Other wise attach the bare copper fixture wire to the green ground screw on the mounting plate. Tuck the wire connections neatly into the ceiling junction box as you are holding the fixture assembly toward the ceiling.
6. Finish mounting the pan (A) by placing it over both mounting screws so that the screws protrude from the keyholes in the bottom of the pan (A). Rotate the pan (A) until the screw are seat in the slots of the keyholes and tighten it with a screwdriver.
7. Install the light bulbs in accordance with the fixture's specifications. **DO NOT EXCEED THE MAXIMUM WATTAGE RATING!**
8. Attach the glass shade(B) to the crown(D), raise the assembly to the pan , aligning the thread hole of pan with crown's hole, then tighten it with the screws(C).

Your installation is now complete. Return power to the junction box and test the fixture.

Fig.1

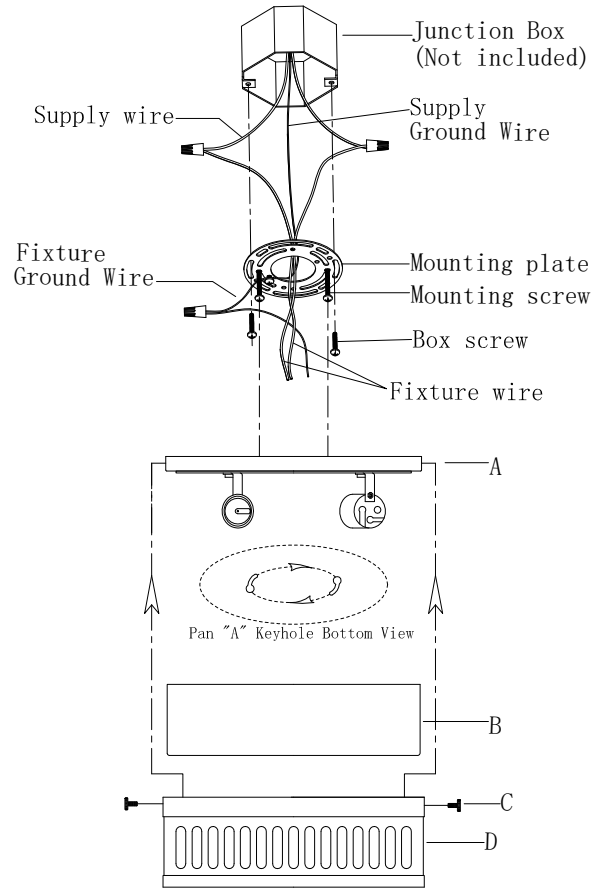

MIN 90°C SUPPLY CONDUCTORS

Fig.2

