

**RECTANGLE DINING TABLE  
TABLE DE SALLE À MANGER RECTÁNGULO  
MESA DE COMEDOR RECTANGLE**

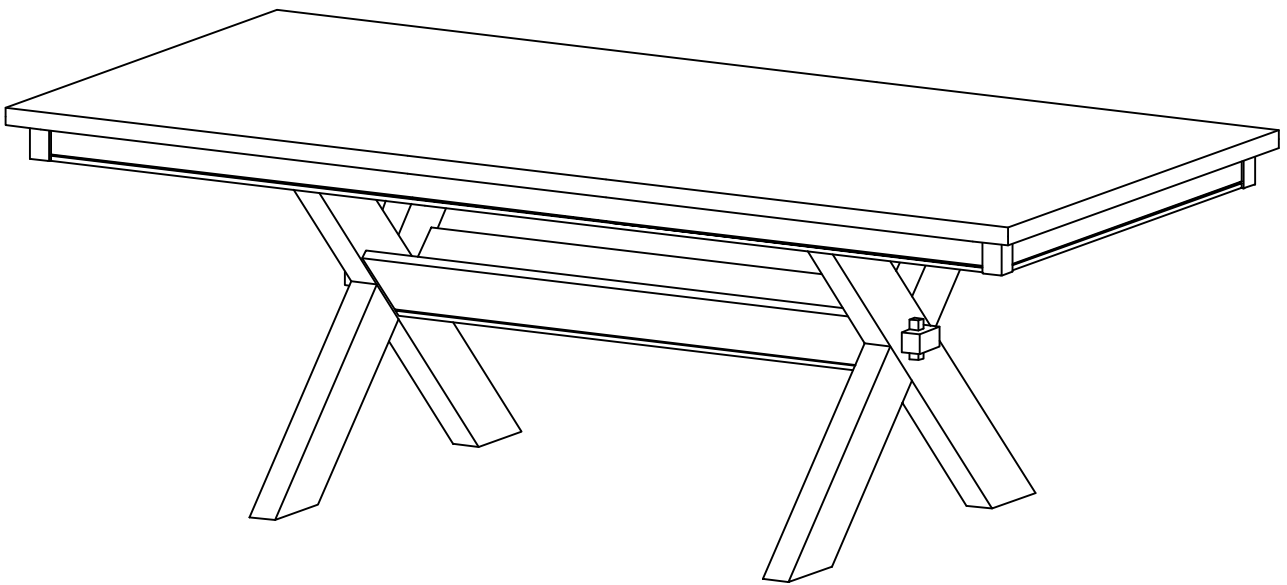

---

## **We are here to help! Before you return it - contact us.**

We do our best to insure that your furniture arrives in excellent condition. In the event that a part is damaged or missing, L.Powell will be happy to provide you with replacement parts, at no charge, within 30 days of purchase, providing the parts are available in our warehouse and the item purchased is part of our current inventory. In order to receive spare parts, at no charge, you must provide proof of purchase within 30 days.

If you need assistance with assembly or replacement parts, please call our Customer Service, prior to returning the item to the store.

## **Nous sommes là pour vous aider! Avant de retourner le produit, veuillez communiquer avec nous.**

Nous faisons tout en notre pouvoir pour que vous receviez votre meuble en parfait état. Toutefois, si une pièce est endommagée ou manquante, L.Powell se fera un plaisir de vous envoyer gratuitement la pièce de rechange, dans les 30 jours suivant l'achat, à condition que nous ayons la pièce en stock et que le produit acheté fasse partie de notre inventaire courant. Afin de recevoir gratuitement la pièce de rechange, vous devez fournir une preuve d'achat dans un délai de 30 jours.







Si vous avez besoin d'une pièce de rechange ou d'aide pour l'assemblage, veuillez communiquer avec le Service à la clientèle de avant de retourner le produit au magasin.

## **Estamos aquí para ayudarle! Antes de regresar el producto, comuníquese con nosotros.**

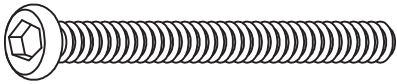
Hacemos todo lo posible para que su mobiliario se le entregue en excelentes condiciones. En caso de que falte una pieza o esté dañada, L.Powell le enviará con gusto la pieza de repuesto sin ningún costo dentro de los 30 días posteriores a la compra, siempre y cuando tengamos en existencia las piezas en nuestros almacenes y que el artículo comprado forme parte de nuestro inventario actual. Para recibir piezas de repuesto, sin costo adicional, debe enviarnos el comprobante de compra dentro de los 30 días después de la compra.

Si necesita ayuda para ensamblar su producto o para obtener piezas de repuesto, llame al Servicio al Cliente de antes de devolver el artículo a la tienda.

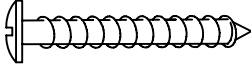
## HARDWARE LIST

			
H1x4 Ø1/4"x2-1/2"	H2x4 Ø5/16"x1-3/4"	H3x4 Ø1/4"	H4x4 Ø1/4"x12mm
			
H5x1 Allen wrench	H6x16 #4x1-1/4"	H7x4 Ø5/16"	H8x4 Ø5/16"x19mm

## PART LIST:

PARTS	DESCRIPTION	QTY
A	TABLE TOP	1
B	MOUNTING PLATE	2
C	TABLE LEG	4
D	STORAGE SHELF	1
E	FINIAL	2

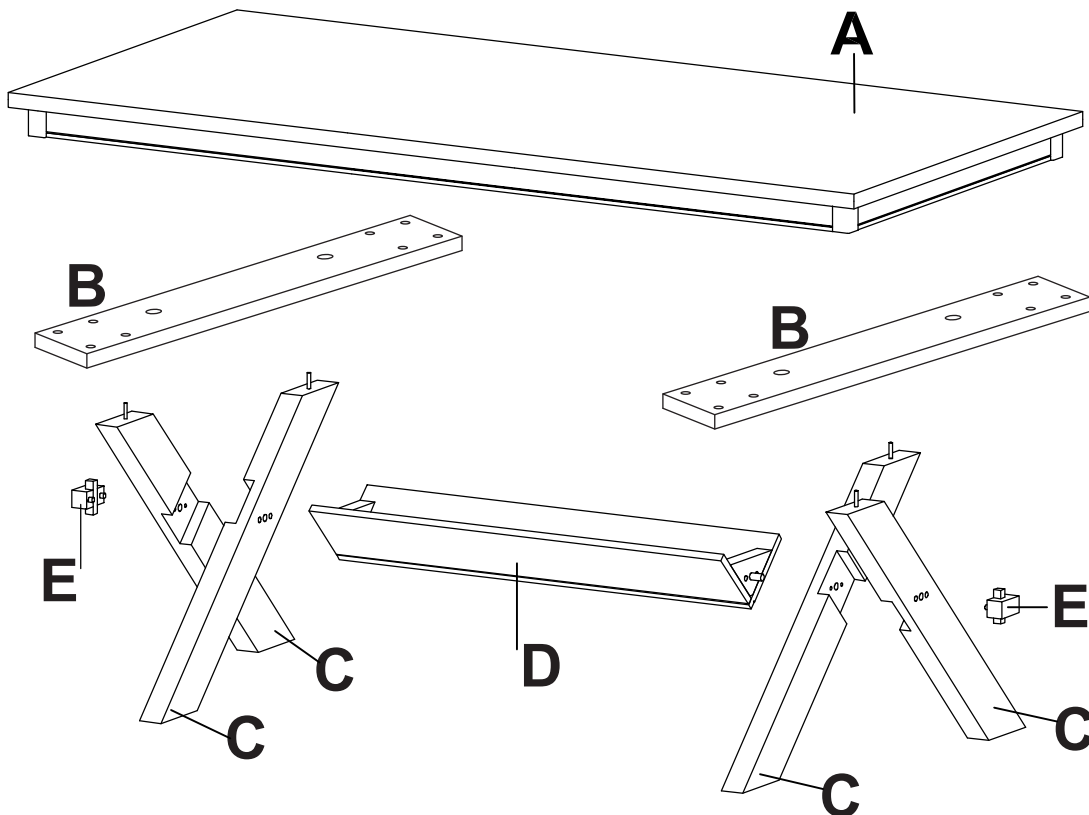

**IMPORTANT:**

1. Do not tighten bolts completely until all bolts are completely lined up and inserted into holes / nuts.
2. Do not over tighten screws and bolts to avoid stripping.
3. Please use hand tools to assemble this product. Do not use power tools.

**IMPORTANT:**

1. Ne serrez pas complètement les boulons jusqu'à ce qu'ils soient bien alignés et insérés dans les trous et les écrous.
2. Ne serrez pas excessivement les boulons pour éviter d'endommager les filets.
3. Veuillez utiliser des outils manuels pour assembler ce produit. Ne pas utiliser d'outils électriques.

**IMPORTANTE:**

1. No apriete completamente los pernos hasta que estén bien alineados e insertados en los orificios y las tuercas.
2. No apriete exageradamente los pernos para evitar dañar las roscas.
3. Favor de utilizar herramientas manuales para ensamblar este producto. No utilizar herramientas eléctricas.



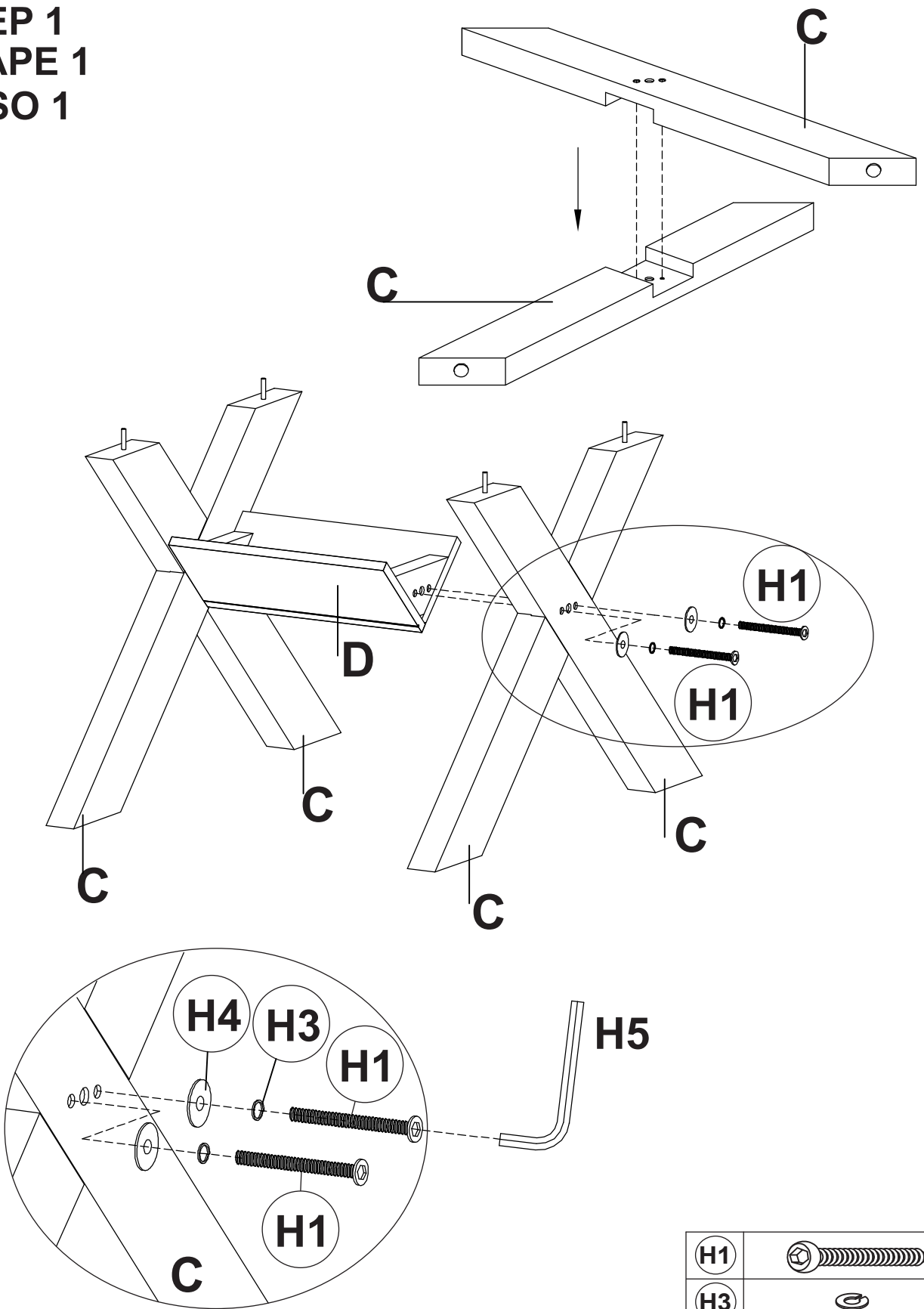

**STEP 1**  
**ÉTAPE 1**  
**PASO 1**

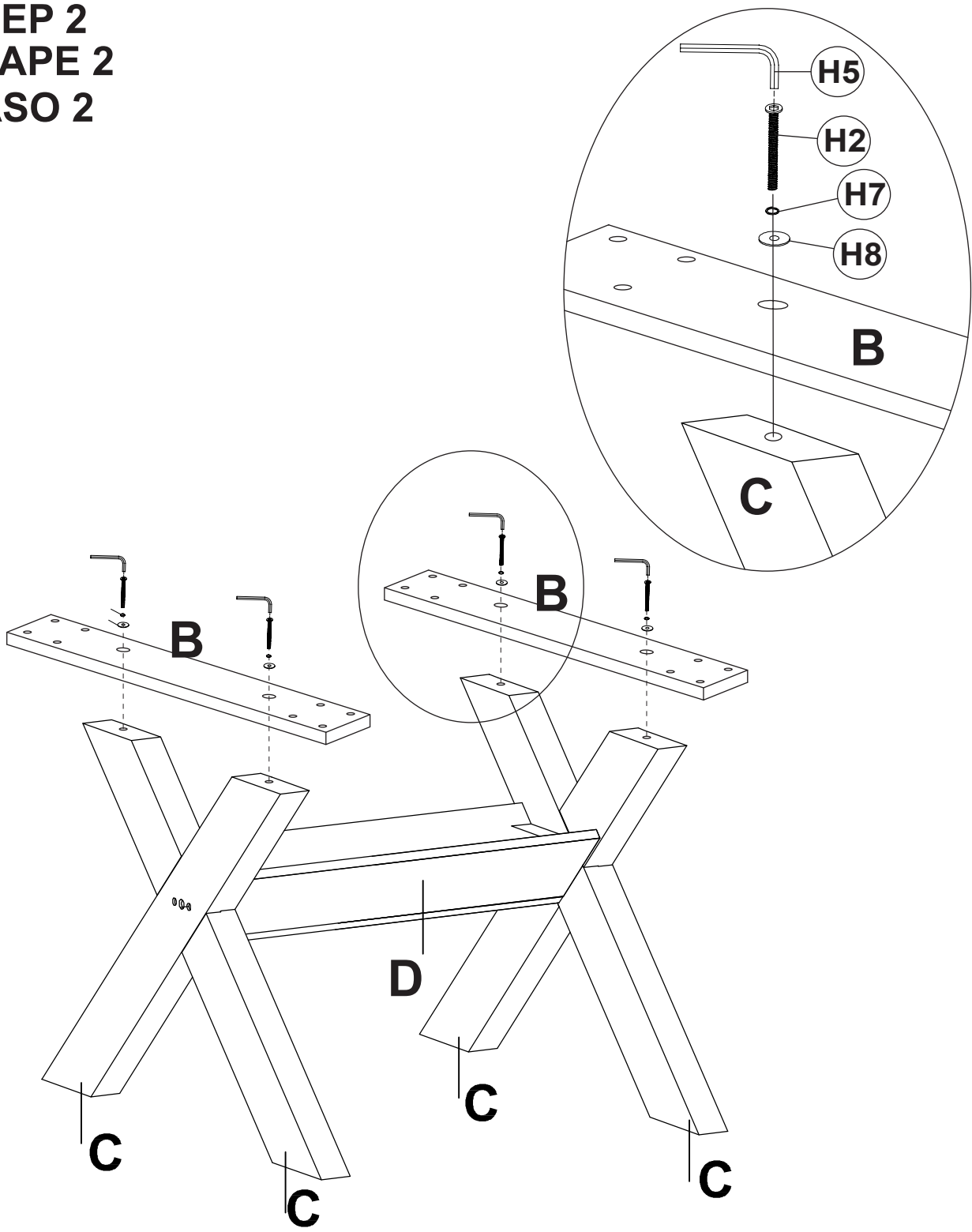

H1		4
H3		4
H4		4
H5		1

**STEP 2**  
**ÉTAPE 2**  
**PASO 2**



<b>H2</b>		4
<b>H5</b>		1
<b>H7</b>		4
<b>H8</b>		4

**STEP 2**  
**ÉTAPE 2**  
**PASO 2**

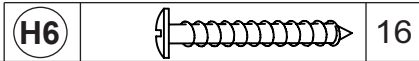
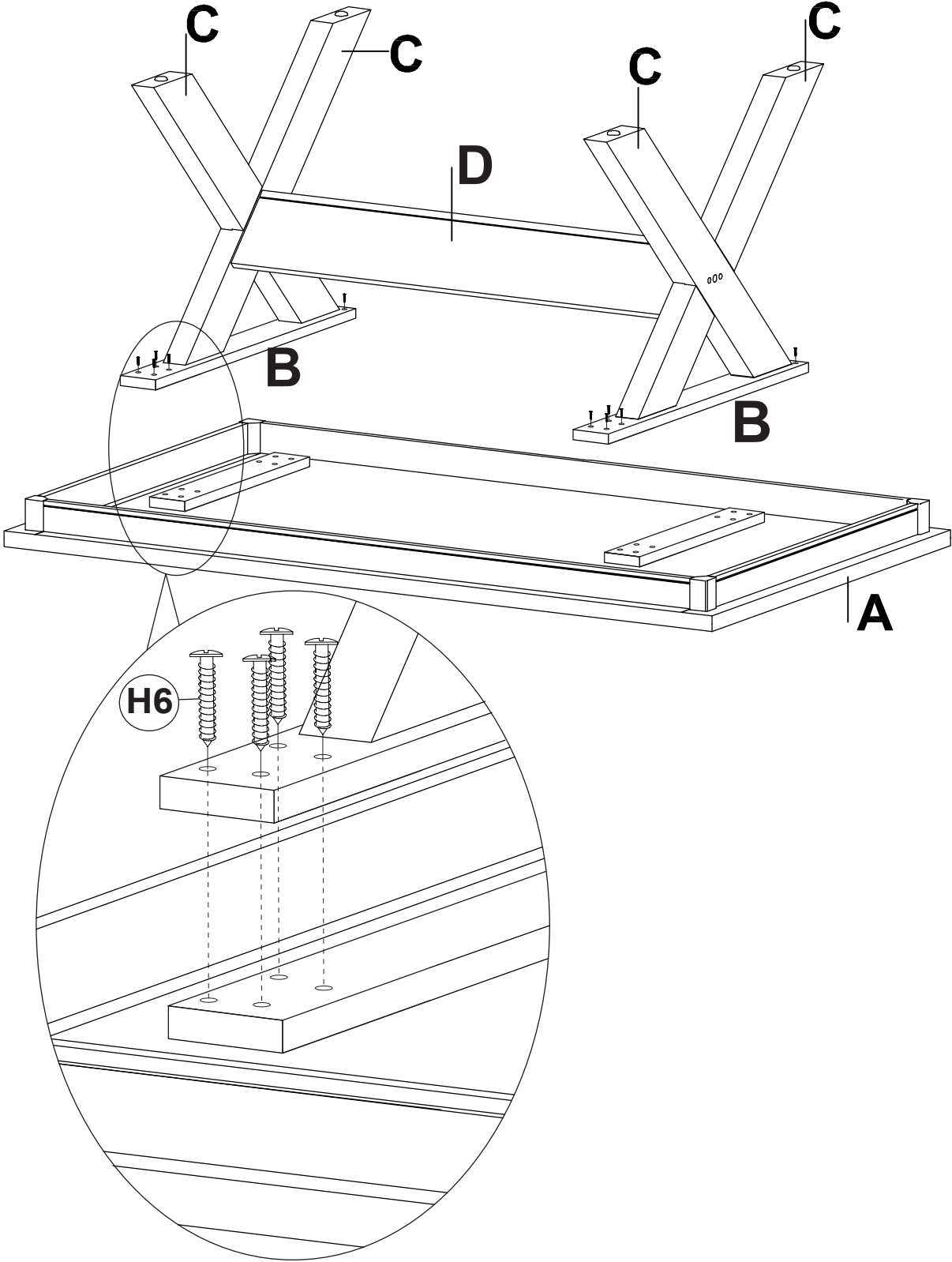

**STEP 3**  
**ÉTAPE 3**  
**PASO 3**

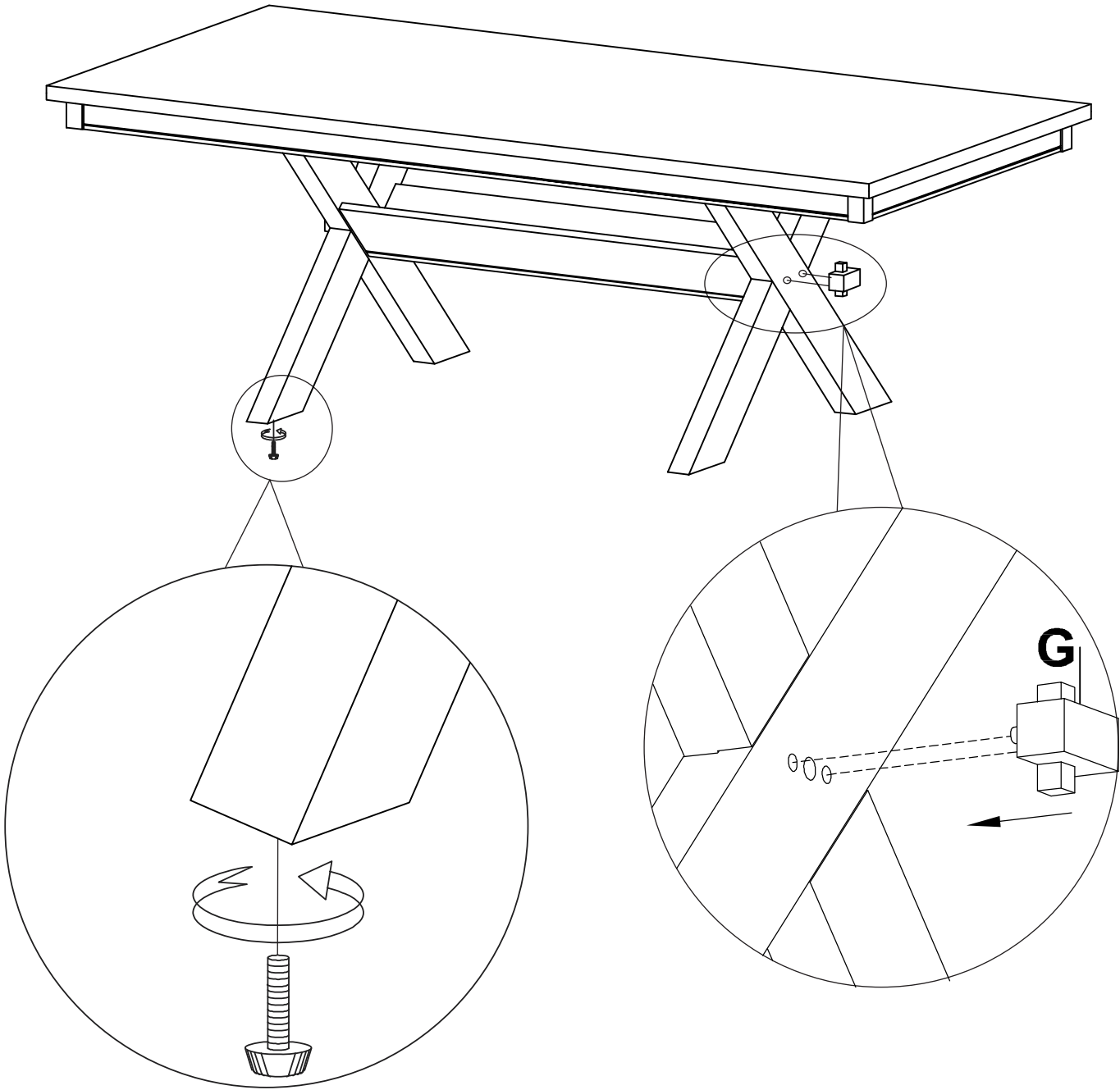

## **LIMITED 6 MONTHS WARRANTY**

## **GARANTIE LIMITÉE DE 6 MOIS**

## **GARANTÍA LIMITADA DE 6 MESES**

### **WHAT IS COVERED**

This product is covered under our manufacturer's 6 months limited warranty

To ensure your complete satisfaction, this warrants to the original purchaser that the Powell supplied item is free from defects in material and workmanship, as of the date of purchase, and that it will, under normal use and proper care, remain so for six months after the date of purchase.

Replacement of missing or initially defective parts will be sent, at no charge, for a period of 30 days from the date of purchase with valid proof of purchase providing the parts are available in our warehouse and the item purchased is part of our current inventory.

### **WHAT IS NOT COVERED**

It remains the customer's responsibility for freight and packaging charges to and from the customer service center. Labor and material charges to remove or replace parts under this warranty are not covered.

This warranty does not cover: Furniture used for commercial purposes, failures caused by improper installation assembly or by improper care, unreasonable or abusive use, freeze damage, acts of God, rust, purchased parts or return freight and packaging charges. Proof of purchase (dated register receipt) is required for warranty claims.

### **HOW TO OBTAIN SERVICE**

For further information, please contact our customer service department,

